

DR[®] POWERWAGON-PREMIER

SAFETY & OPERATING INSTRUCTIONS



! WARNING!

READ AND UNDERSTAND THIS MANUAL AND ALL INSTRUCTIONS BEFORE OPERATING THE DR POWERWAGON-PREMIER.

THANK YOU!

Congratulations on your purchase of a new DR POWERWAGON-PREMIER!

We have done our utmost to ensure that your DR POWERWAGON-PREMIER will be one of the most trouble-free and satisfying pieces of equipment you have ever owned. Please let us know of any questions you may have. We want to answer them as quickly as possible. When you do call, please have your serial number or order number handy. **For technical assistance, please call Toll-Free 1-800-DR-OWNER (376-9637) and one of our Technical Support Representatives will be happy to help you.** We also hope to hear from you on how much you like your new helper.

In addition, please tell your friends about your new DR POWERWAGON-PREMIER! Having DR Owners spread the word about our products and our way of doing business is the best advertising we can have, and the best way to help us provide even better service in the years to come.

THANKS ONCE AGAIN!



for all of us at
Country Home Products, Inc.

SALES MANAGER

COPYRIGHT

©2007 Country Home Products, Inc. All rights reserved.



DR® Power Equipment
A division of Country Home Products®
127 Meigs Road
Vergennes, VT 05491

Toll-free phone: 1-800-DR-OWNER (376-9637)

Fax: 1-802-877-1213

Web site: www.dr-owner.com

Table of Contents

CHAPTER 1	1
INTRODUCING THE DR POWERWAGON-PREMIER	1
Conventions used in this manual.....	1
CHAPTER 2	2
GENERAL SAFETY RULES	2
Labels	2
Protecting Yourself.....	4
Slope Operation	5
Safety for Children.....	5
Safety with Gasoline-Powered Machines	6
General Safety	7
A Note To All Users	8
Additional Information and Potential Changes	8
CHAPTER 3	9
SETTING UP YOUR DR POWERWAGON-PREMIER	9
DR POWERWAGON-PREMIER Controls And Features	9
Unpacking the DR POWERWAGON-PREMIER	10
Check the Tire Pressure	10
Adding Oil and Gasoline	11
Connect the Battery Wires	12
CHAPTER 4	13
OPERATING YOUR DR POWERWAGON-PREMIER.....	13
Before Starting the Engine.....	13
Electric Starting.....	13
Manual Recoil Starting	14
Operating	14
Stopping	15
Operating Tips	15
Loading.....	15
Slopes and Uneven Terrain	16
Dumping	17
CHAPTER 5	18
MAINTAINING THE DR POWERWAGON-PREMIER	18
Regular Maintenance Checklist	18
Battery Care	19
Charging the Battery	19
Lubrication	20
Changing the Engine Oil.....	21
Removing and Replacing the Belt	22
Removing and Replacing the Front Wheels.....	24
Adjusting the Parking Brake	25
Parking Brake Cable Adjustment.....	26
Changing the Parking Brake Pads	26

Replacing the Throttle Cable	28
Adjusting the Shift Lever.....	30
Adjusting the Wheel Clutch	31
End of Season and Storage.....	32
Recycling a Used Battery.....	32
CHAPTER 6	33
TROUBLESHOOTING	33
Troubleshooting Table.....	33
CHAPTER 7	36
PARTS LISTS, SCHEMATIC DIAGRAMS AND WARRANTY	36
Parts List - Main Frame Assembly.....	36
Schematic - Main Frame Assembly.....	37
Parts List - Handlebar/Controls Assembly	38
Schematic - Handlebar/Controls Assembly.....	39
Parts List - Main Axle Assembly	40
Schematic - Main Axle Assembly.....	41
Parts List - Molded Body Assembly.....	42
Schematic - Molded Body Assembly	43
Notes:	44
Daily Checklist for the POWERWAGON-PREMIER	46

INTRODUCING THE DR POWERWAGON-PREMIER

This manual will help you set up and safely operate your new DR POWERWAGON-PREMIER. Careful adherence to the safety and operating instructions in this manual will ensure many years of productive use. Please let us know of any questions you may have. We want to answer them as quickly as possible. When you do call, please have your serial number and/or order number handy. **For technical assistance, please call Toll-Free 1-800-DR-OWNER (376-9637) and one of our Technical Support Representatives will be happy to help you.**

Conventions used in this manual

! WARNING!

THIS INDICATES A HAZARDOUS SITUATION, WHICH, IF NOT AVOIDED, COULD RESULT IN DEATH OR SERIOUS INJURY.

! CAUTION!

THIS INDICATES A HAZARDOUS SITUATION, WHICH, IF NOT AVOIDED, COULD RESULT IN MINOR OR MODERATE INJURY.

! NOTICE!

THIS INFORMATION IS IMPORTANT IN THE PROPER USE OF YOUR MACHINE. FAILURE TO FOLLOW THIS INSTRUCTION COULD RESULT IN DAMAGE TO YOUR MACHINE OR PROPERTY.

Tip: This is a helpful hint to guide you in getting the most out of your DR POWERWAGON-PREMIER.

Tools Needed: This indicates you will need a specific tool to perform a maintenance function on your DR POWERWAGON-PREMIER.

NOTE: *This information may be helpful to you.*

If you are ever unsure about an action you are about to take, don't do it. Contact Country Home Products' Toll-Free support at **1-800-DR-OWNER (376-9637)** for help or information.

GENERAL SAFETY RULES

WARNING!

READ THIS *SAFETY & OPERATING INSTRUCTIONS* MANUAL BEFORE YOU USE THE DR POWERWAGON-PREMIER. BECOME FAMILIAR WITH THE SERVICE RECOMMENDATIONS TO ENSURE THE BEST PERFORMANCE FROM YOUR MACHINE.

Labels

Your DR POWERWAGON-PREMIER carries prominent labels as reminders for its proper and safe use. Shown below are copies of all the labels that appear on the equipment. Take a moment to study them and make a note of their location on your DR POWERWAGON-PREMIER as you assemble and *before* you operate the machine. Replace damaged or missing safety and information labels immediately.

**WARNING: Check Oil
Before Starting Engine**

#137581

**WARNING: Add Oil
Before Starting Engine**

#127811

Make sure you add oil before starting the engine; the unit is shipped without oil. Fill the oil reservoir slowly to make sure you don't overfill it.

DUMP LEVER

#153421

**DO NOT OPERATE
POWERWAGON
ON SLOPES
GREATER THAN
20 DEGREES**

#153441

**BE SURE DUMP
LEVER IS SECURELY
LATCHED BEFORE
LOADING OR
OPERATING
POWERWAGON**

#153431

DR® POWERWAGON™

R N1234

WARNING! AVOID SERIOUS INJURY OR DEATH
READ AND UNDERSTAND THE OPERATOR'S MANUAL. MAXIMUM RECOMMENDED LOAD 500 LBS. OVERLOADING MAY BE DANGEROUS AND PERMANENTLY DAMAGE UNIT. NEVER CARRY PASSENGERS!

<p>OPERATE SAFELY</p> <p>Release throttle lever when shifting into any gear. Shift transmission, then increase throttle slowly to move forward or backward.</p> <p>Use care when operating machine in reverse. Check to be sure there is nothing behind you which could cause you to trip or prevent you from using the controls freely.</p> <p>When operated in fourth gear with full throttle the machine can travel up to 5.5 mph. If this speed is too fast, choose a lower gear.</p>	<p>BEFORE STARTING</p> <ul style="list-style-type: none"> • Read Operator's Manual. • Set brake. • Check gas and oil levels. • Check tires for proper inflation. • Check latch on dump body. • Shift transmission to neutral. 	<p>TO OPERATE</p> <ul style="list-style-type: none"> • Release parking brake. • Shift transmission into desired gear by positioning the pin on the lever next to the desired gear. Use 1st gear for loads over 300 pounds, and whenever you need more power or more control of the bed. • Limit loads to less than 400 pounds on slopes. • To shift into reverse, pull shift lever back to the R (reverse) position. • To engage the drive, with the engine running and after the shift lever is in the desired gear, slowly squeeze the wheel clutch lever to engage wheels and start moving. <p><i>Note: Use extra caution when engaging reverse gear and backing up.</i></p>	<p>TO STOP ENGINE</p> <ul style="list-style-type: none"> • Release the wheel clutch lever. • Set brake by squeezing the lever on the right handlebar, set lock, shift to N (neutral). • Turn key to OFF position. <p><i>Electric-starting models - remove key for safety.</i></p>
	<p>TO START ENGINE</p> <ul style="list-style-type: none"> • Move throttle to RUN position. • Shift transmission to N (neutral). • If engine is cold, push primer bulb on engine 3 times. • Turn key to START to engage the starter; as soon as engine starts, release the key. 	<p>OFF START</p>	<p>TO DUMP</p> <ul style="list-style-type: none"> • Stand at rear of dump body. (On stake body model lift or remove the front panel). • Pull dump release lever, lift dump body from rear. • After dumping, push dump body down by hand. <p><i>Be sure dump release lever engages dump locking pin completely before loading or operating further.</i></p>

#180531B

Protecting Yourself

 WARNING!

THIS IS A HIGH-POWERED MACHINE, WITH MOVING PARTS OPERATING WITH HIGH ENERGY AT HIGH SPEEDS. USE PROPER CLOTHING AND SAFETY GEAR WHEN OPERATING THIS MACHINE TO PREVENT OR MINIMIZE THE RISK OF SEVERE INJURY. YOU MUST OPERATE THE MACHINE SAFELY. UNSAFE OPERATION CAN CREATE A NUMBER OF HAZARDS FOR YOU. ALWAYS TAKE THE FOLLOWING PRECAUTIONS WHEN OPERATING THIS MACHINE:

- **WEAR SHOES WITH NON-SLIP TREADS WHEN USING YOUR DR POWERWAGON-PREMIER. IF YOU HAVE SAFETY SHOES, WE RECOMMEND WEARING THEM. DO NOT USE THE MACHINE WHILE BAREFOOT OR WEARING OPEN SANDALS.**
 - **AVOID WEARING LOOSE CLOTHING OR JEWELRY, WHICH CAN CATCH ON THE MACHINE'S MOVING PARTS.**
 - **USE EAR PROTECTORS OR EAR PLUGS RATED FOR AT LEAST 20 DBA TO PROTECT YOUR HEARING.**
 - **NEVER ALLOW PEOPLE WHO ARE UNFAMILIAR WITH THESE INSTRUCTIONS TO USE THE DR POWERWAGON-PREMIER. ALLOW ONLY RESPONSIBLE INDIVIDUALS WHO ARE FAMILIAR WITH THESE RULES OF SAFE OPERATION TO USE YOUR MACHINE.**
 - **NEVER PLACE YOUR HANDS, FEET, OR ANY PART OF YOUR BODY NEAR OR UNDER ANY MOVING PART WHILE THE MACHINE IS RUNNING.**
 - **TO BE SAFE, DO NOT OPERATE THE MACHINE NEAR SMALL CHILDREN OR PETS, AND NEVER ALLOW CHILDREN TO OPERATE THE DR POWERWAGON-PREMIER.**
 - **THE MUFFLER AND ENGINE BECOME VERY HOT AND CAN CAUSE A SEVERE BURN; DO NOT TOUCH.**
 - **NEVER, UNDER ANY CONDITIONS, REMOVE, BEND, CUT, FIT, WELD, OR OTHERWISE ALTER STANDARD PARTS ON THE DR POWERWAGON-PREMIER. THIS INCLUDES ALL SHIELDS AND GUARDS. MODIFICATIONS TO YOUR MACHINE COULD CAUSE PERSONAL INJURIES AND WILL VOID YOUR WARRANTY.**
-

Slope Operation

WARNING!

SLOPES ARE A MAJOR FACTOR RELATED TO SLIP AND FALL ACCIDENTS, WHICH CAN RESULT IN SEVERE INJURY. ALL SLOPES REQUIRE CAUTION. IF YOU FEEL UNEASY ON A SLOPE, DO NOT USE THE DR POWERWAGON-PREMIER ON IT. ALWAYS TAKE THE FOLLOWING PRECAUTIONS WHEN USING THIS MACHINE ON SLOPES:

ALWAYS:

- TRAVERSE UP AND DOWN THE FACE OF SLOPES; NEVER ACROSS. EXERCISE EXTREME CAUTION WHEN CHANGING DIRECTION ON SLOPES.
- WATCH FOR HOLES, RUTS, OR BUMPS IN THE LANDSCAPE.
- USE 1ST GEAR ON SLOPES WITH A MAXIMUM LOAD OF 400 LBS.

NEVER:

- OPERATE NEAR DROP-OFFS, DITCHES, OR EMBANKMENTS; YOU COULD LOSE YOUR FOOTING OR BALANCE.
 - OPERATE ON SLOPES GREATER THAN 20 DEGREES, OR ANY EXCESSIVELY STEEP SLOPES.
 - OPERATE ON WET, OR SLIPPERY SLOPES; REDUCED TRACTION COULD RESULT IN SLIPPING.
 - PARK THE DR POWERWAGON-PREMIER ON A STEEP GRADE OR SLOPE.
-

Safety for Children

WARNING!

TRAGIC ACCIDENTS CAN OCCUR IF THE OPERATOR IS NOT ALERT TO THE PRESENCE OF CHILDREN. CHILDREN ARE OFTEN ATTRACTED TO THE MACHINE AND THE HAULING ACTIVITY. NEVER ASSUME THAT CHILDREN WILL REMAIN WHERE YOU LAST SAW THEM.

- KEEP CHILDREN OUT OF THE WORK AREA AND UNDER THE WATCHFUL CARE OF A RESPONSIBLE ADULT.
 - BE ALERT AND ALWAYS TURN OFF THE DR POWERWAGON-PREMIER ENGINE IF CHILDREN ENTER THE WORK AREA.
 - BEFORE, AND WHILE MOVING BACKWARDS, LOOK BEHIND, AND DOWN FOR SMALL CHILDREN.
 - NEVER ALLOW CHILDREN TO OPERATE THE DR POWERWAGON-PREMIER.
 - USE EXTRA CARE WHEN APPROACHING BLIND CORNERS, SHRUBS, TREES, OR OTHER OBJECTS THAT MAY OBSCURE YOUR VISION.
-

Safety with Gasoline-Powered Machines

WARNING!

GASOLINE IS A HIGHLY FLAMMABLE LIQUID. GASOLINE ALSO GIVES OFF FLAMMABLE VAPOR THAT CAN BE EASILY IGNITED AND CAUSE A FIRE OR EXPLOSION. NEVER OVERLOOK THE HAZARDS OF GASOLINE. ALWAYS FOLLOW THESE PRECAUTIONS:

- **NEVER RUN THE ENGINE IN AN ENCLOSED AREA OR WITHOUT PROPER VENTILATION AS THE EXHAUST FROM THE ENGINE CONTAINS CARBON MONOXIDE, WHICH IS AN ODORLESS, TASTELESS, AND DEADLY POISONOUS GAS.**
 - **STORE ALL FUEL AND OIL IN CONTAINERS SPECIFICALLY DESIGNED AND APPROVED FOR THIS PURPOSE AND KEEP AWAY FROM HEAT AND OPEN FLAME, AND OUT OF THE REACH OF CHILDREN.**
 - **FILL THE GASOLINE TANK OUTDOORS WITH THE ENGINE OFF AND ALLOW THE ENGINE TO COOL COMPLETELY. DO NOT HANDLE GASOLINE IF YOU OR ANYONE NEARBY IS SMOKING, OR IF YOU ARE NEAR ANYTHING THAT COULD CAUSE IT TO IGNITE OR EXPLODE. REPLACE THE FUEL TANK AND FUEL CONTAINER CAPS SECURELY.**
 - **IF YOU SPILL GASOLINE, DO NOT ATTEMPT TO START THE ENGINE. MOVE THE MACHINE AWAY FROM THE AREA OF THE SPILL AND AVOID CREATING ANY SOURCE OF IGNITION UNTIL THE GAS VAPORS HAVE DISSIPATED. WIPE UP ANY SPILLED FUEL TO PREVENT A FIRE HAZARD AND PROPERLY DISPOSE OF THE WASTE.**
 - **ALLOW THE ENGINE TO COOL COMPLETELY BEFORE STORING THE DR POWERWAGON-PREMIER IN ANY ENCLOSURE. NEVER STORE THE MACHINE WITH GAS IN THE TANK OR A FUEL CONTAINER, NEAR AN OPEN FLAME OR SPARK SUCH AS A WATER HEATER.**
 - **NEVER MAKE ADJUSTMENTS OR REPAIRS WITH THE ENGINE RUNNING. DISCONNECT THE SPARK PLUG WIRE AND KEEP THE WIRE AWAY FROM THE SPARK PLUG TO PREVENT ACCIDENTAL STARTING.**
 - **NEVER CHECK FOR AN IGNITION SPARK WITH THE SPARK PLUG OR SPARK PLUG WIRE REMOVED. USE AN APPROVED SPARK TESTER.**
 - **NEVER TAMPER WITH SAFETY DEVICES. CHECK THEIR PROPER OPERATION REGULARLY.**
 - **DO NOT CHANGE THE ENGINE GOVERNOR SETTINGS OR MODIFY THE ENGINE SPEED. MODIFICATIONS WILL VOID YOUR WARRANTY.**
 - **TO REDUCE FIRE HAZARD, KEEP THE ENGINE COOLING FAN AND MUFFLER AREA FREE OF DEBRIS BUILD-UP SUCH AS LEAVES, GRASS, OIL, GREASE OR ANY OTHER COMBUSTIBLE MATERIAL.**
 - **NEVER OPERATE THE ENGINE WITHOUT THE MUFFLER. INSPECT THE MUFFLER PERIODICALLY AND REPLACE IF NECESSARY. IF EQUIPPED WITH A MUFFLER DEFLECTOR, INSPECT THE DEFLECTOR PERIODICALLY AND REPLACE IF NECESSARY.**
 - **NEVER OPERATE THE ENGINE WITH THE AIR CLEANER OR COVER OVER THE CARBURETOR AIR INTAKE REMOVED, EXCEPT FOR ADJUSTMENT. REMOVAL OF SUCH PARTS COULD CREATE A FIRE HAZARD. DO NOT USE FLAMMABLE SOLUTIONS TO CLEAN AIR FILTER.**
 - **ALWAYS CHECK FUEL LINES AND FITTINGS FREQUENTLY FOR CRACKS OR LEAKS, REPLACE IF NECESSARY.**
-

General Safety

CAUTION!

- THE DR POWERWAGON-PREMIER MUST BE OPERATED SAFELY TO PREVENT OR MINIMIZE THE RISK OF MINOR OR MODERATE INJURY. UNSAFE OPERATION CAN CREATE A NUMBER OF HAZARDS FOR YOU. ALWAYS TAKE THE FOLLOWING PRECAUTIONS WHEN OPERATING THIS MACHINE:
- KEEP IN MIND THAT THE OPERATOR OR USER IS RESPONSIBLE FOR ACCIDENTS OR HAZARDS OCCURRING TO OTHER PEOPLE, THEIR PROPERTY, AND THEMSELVES.
- YOUR DR POWERWAGON-PREMIER IS NOT A PLAYTHING. EXERCISE EXTREME CAUTION AT ALL TIMES. THE DESIGN OF THIS MACHINE IS TO HAUL MATERIAL. DO NOT USE IT FOR ANY OTHER PURPOSE.
- GIVE COMPLETE AND UNDIVIDED ATTENTION TO THE JOB AT HAND. BEFORE YOU USE YOUR NEW MACHINE, BE SURE YOU KNOW HOW TO ENGAGE THE PARKING BRAKE AND STOP THE DR POWERWAGON-PREMIER AT A MOMENT'S NOTICE.
- ALWAYS OPERATE THE DR POWERWAGON-PREMIER FROM BEHIND THE HANDLEBARS, NEVER FROM THE SIDE.
- NEVER USE THE DR POWERWAGON-PREMIER TO DRAG, TOW, OR PUSH ITEMS.
- DO NOT OVERLOAD THE DR POWERWAGON-PREMIER. BE CAREFUL OF TOP-HEAVY LOADS. THE HIGHER THE LOAD, THE MORE CHANCE THE MACHINE MAY TIP OVER. ALSO, LOADS MAY SHIFT DURING OPERATION; SO TO BE SAFE, SECURE YOUR LOADS AND EVEN THEM OUT WHEN POSSIBLE.
- THE MAXIMUM LOAD IS 500 LBS. ON LEVEL TERRAIN.
- USE 1ST GEAR WITH LOADS OVER 400 LBS. EXCESSIVE SPEED CAN BE DANGEROUS. OPERATE THE MACHINE IN THE LOWEST GEAR THAT IS SATISFACTORY TO DO THE JOB.
- USE CAUTION WHEN MOVING DOWNHILL AND BRAKING. APPLY THE PARKING BRAKE SLOWLY TO AVOID TIPPING FORWARD.
- WHEN SHIFTING TO REVERSE, BE CAREFUL TO AVOID TIPPING AS THE SWIVEL WHEEL CHANGES DIRECTION.
- WATCH FOR TRAFFIC WHEN OPERATING NEAR ROADWAYS.
- NEVER ALLOW PEOPLE OR PETS TO RIDE IN THE DR POWERWAGON-PREMIER.
- IF THE MACHINE SHOULD START MAKING AN UNUSUAL NOISE OR VIBRATION, STOP THE ENGINE AND WAIT FIVE (5) MINUTES TO COOL. VIBRATION IS GENERALLY A WARNING SIGN OF TROUBLE. DISCONNECT THE SPARK PLUG WIRE AND INSPECT FOR DAMAGED PARTS. CLEAN AND REPAIR AND/OR REPLACE DAMAGED PARTS.
- BUILT-IN SAFETY FEATURES, SUCH AS THE OPERATOR PRESENCE SYSTEM, ARE EFFECTIVE ONLY WHEN MAINTAINED AND KEPT IN PLACE.
- ALWAYS KEEP THE EQUIPMENT IN A GOOD SAFE OPERATING CONDITION. ALWAYS MAKE CERTAIN NUTS AND BOLTS ARE TIGHT AND ALWAYS USE THE SUPPLIED SELF-LOCKING HARDWARE; DO NOT SUBSTITUTE. USE ONLY APPROVED DR PARTS.
- USE THE DR POWERWAGON-PREMIER ONLY IN DAYLIGHT.
- WHILE USING THE MACHINE, DO NOT HURRY OR TAKE THINGS FOR GRANTED. WHEN IN DOUBT ABOUT THE EQUIPMENT OR YOUR SURROUNDINGS, STOP THE MACHINE AND TAKE THE TIME TO LOOK THINGS OVER. MAKE SURE THAT YOU HAVE 100% CONTROL OF THE MACHINE AT ALL TIMES.
- NEVER LEAVE THE DR POWERWAGON-PREMIER UNATTENDED WITH THE ENGINE RUNNING.
- DO NOT OPERATE THE MACHINE WHEN UNDER THE INFLUENCE OF ALCOHOL, DRUGS, OR MEDICATION.

! CAUTION!

- SEE MANUFACTURER'S INSTRUCTIONS FOR PROPER OPERATION AND INSTALLATION OF ACCESSORIES. ONLY USE ACCESSORIES APPROVED BY COUNTRY HOME PRODUCTS, INC.
 - NO LIST OF WARNINGS AND CAUTIONS CAN BE ALL-INCLUSIVE. IF SITUATIONS OCCUR THAT ARE NOT COVERED BY THIS MANUAL, THE OPERATOR MUST APPLY COMMON SENSE AND OPERATE THIS MACHINE IN A SAFE MANNER. CALL TOLL-FREE 1-800-DR-OWNER (376-9637) FOR ASSISTANCE.
-

A Note To All Users

Under California law, and the laws of some other states, you are not permitted to operate an internal combustion engine using hydrocarbon fuels without an engine spark arrester. This also applies to operation on US Forest Lands. All DR POWERWAGON-PREMIERS shipped to California and Washington State are provided with spark arresters. Failure of the owner/operator to maintain this equipment in compliance with state regulations is a misdemeanor under California law and may be in violation of other state and/or federal regulations. Contact your local fire marshal or forest service for specific information in your area.

Additional Information and Potential Changes

Country Home Products, Inc. reserves the right to discontinue, change, and improve its products at any time without notice or obligation to the purchaser. The descriptions and specifications contained in this manual were in effect at printing. Equipment described within this manual may be optional. Some illustrations may not be applicable to your machine.

SETTING UP YOUR DR POWERWAGON-PREMIER

This chapter outlines a few simple steps you will need to follow to set up your new machine before you use it. It may be helpful to familiarize yourself with the controls and features on your DR POWERWAGON-PREMIER by reviewing the picture on this page before beginning the steps outlined in this chapter.

DR POWERWAGON-PREMIER Controls And Features

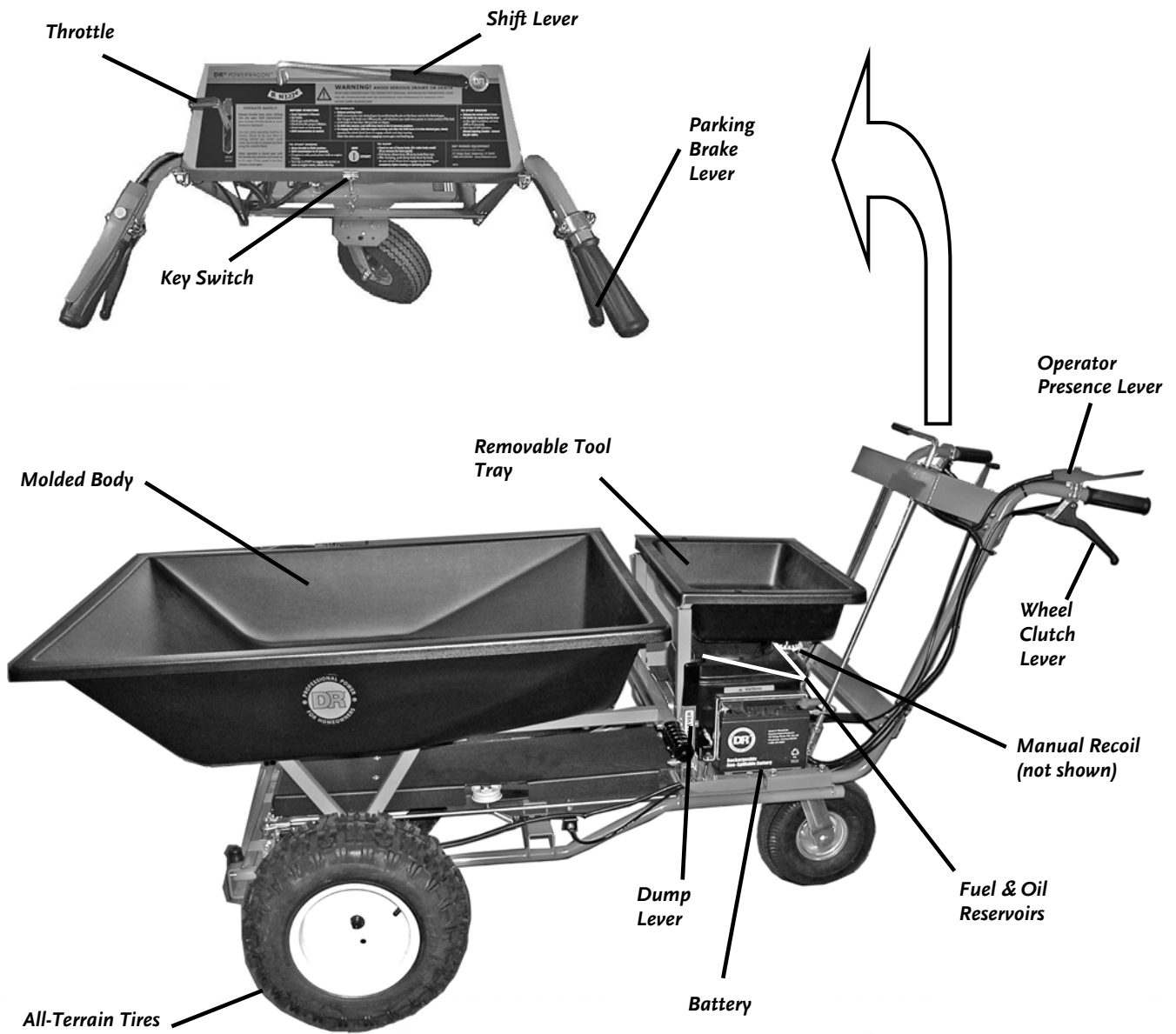

Figure 1

Unpacking the DR POWERWAGON-PREMIER

Tools & Supplies Needed:

- Blade Screwdriver
- Hammer
- Knife
- Gloves
- Eye protection
- Metal shears

WARNING!

ALWAYS WEAR EYE PROTECTION WHEN CUTTING THE BANDING. THE BANDING MAY HAVE A LOT OF TENSION ON IT AND MAY SNAP, STRIKING YOU WHEN CUT. ALWAYS STAND TO ONE SIDE WHEN CUTTING THE BAND.

1. Stand to one side and cut the banding.
2. Remove the top of the carton. Cut the cardboard top to bottom on one of the narrow sides of the box and peel it off the pallet. Be careful of the staples.
3. Using a Screwdriver and/or Hammer, pry off the fasteners and cut any ties holding the machine to the pallet.
4. Roll the DR POWERWAGON-PREMIER off the pallet. Do not discard your pallet and packaging material until you are fully satisfied with your machine.

NOTICE!

BE SURE TO FILL YOUR ENGINE WITH OIL AND GAS BEFORE USE. SEE PAGE 11.

Check the Tire Pressure

The recommended tire pressures are:

- All-Terrain Tires 10-14 lbs.
- Turf Tread Tires 14-28 lbs. (optional accessory, sold separately)
- Swivel Tire 30-50 lbs.

NOTE: *The heavier the load, the higher the tire pressure should be. Do not go above the maximum recommended load or pressure.*

Adding Oil and Gasoline

! NOTICE!

YOU MUST ADD OIL BEFORE STARTING THE ENGINE. THIS MACHINE SHIPPED WITHOUT OIL. TRACES OF OIL MAY BE IN THE RESERVOIR FROM FACTORY TESTING, BUT YOU MUST ADD OIL BEFORE STARTING THE ENGINE. FILL THE RESERVOIR SLOWLY, CHECKING THE DIPSTICK FREQUENTLY TO AVOID OVERFILLING.

Engine Oil Capacity	
Briggs & Stratton 6.25 Torque, Quantum	16-22 oz. (0.45-0.63L)

! NOTICE!

TO GET AN ACCURATE READING WHEN CHECKING THE OIL LEVEL :

- **THE MACHINE SHOULD BE ON A LEVEL SURFACE.**
- **THE DIPSTICK SHOULD BE SCREWED DOWN ON BRIGGS & STRATTON ENGINES.**

Tip: To avoid confusion, we recommend leaving the Caps on the Fuel and Oil Fills until you are ready to pour either gasoline or oil into the correct Fill.

Use only SAE 30 High Detergent oil. Other types of oil could cause problems operating your machine. Please refer to your Engine Owner's Manual for detailed oil information.

NOTE: You must remove the tool tray to access the Oil and Fuel Reservoirs.

1. Place the machine on a level surface and initially add 16 oz. (1/2 quart) of SAE 30 High Detergent oil recommended by the Engine Manufacturer and wait one minute for the oil to settle (**Figure 2**).
2. Check the Dipstick and continue adding a few ounces of oil at a time, rechecking the Dipstick until the oil reaches the fill mark. Be careful not to overfill (**Figure 2**).
3. Fill the Fuel Tank to not more than 1/4" from the bottom of the Fill Neck with fresh, unleaded gas. See the Engine Manufacturer's Owner's Manual for more information.



Figure 2

Connect the Battery Wires

Connect the red wires to each other (**Figure 3**). The black wires were connected at the factory.



Figure 3

OPERATING YOUR DR POWERWAGON-PREMIER

This chapter covers the procedures for starting and stopping your new DR POWERWAGON-PREMIER and discusses basic operation features.

Before Starting the Engine

1. Check the oil level every time you use the machine (**Figure 2** on page 11).
2. Check the gas level (**Figure 2** on page 11).
3. Check the tires for proper inflation.
4. Make sure to secure the Dump Latch.
5. Set the Parking Brake by squeezing the Brake Lever (**Figure 5**) on the right Handlebar and lift up on the Parking Brake Lock (**Figure 5**), locking the lever in place. To release the Parking Brake, just squeeze the Parking Brake Lever again.

NOTE: The DR POWERWAGON-PREMIER is equipped with an Operator Presence Control for added safety. The Operator Presence Lever must be depressed whenever the Shift Lever is in gear, or the engine will stop. You may run the engine without depressing the Operator Presence Lever (**Figure 4**) only if the Shift Lever is in the "N" (Neutral) position (**Figure 6**).

Electric Starting

1. Move the Shift Lever to the "N" (Neutral) position (**Figure 6**).
2. Move the Throttle to the RUN position.
3. If the engine is cold, depress the Primer Bulb three (3) times (**Figure 7** on page 14). In cold weather, you may need to depress additional times, being sure that the Bulb inflates between pumps.
4. Turn the Key to the START position (**Figure 6**). As soon as the engine starts, release the Key, and it will return to the RUN position.
5. Move the Throttle to the desired Engine speed.

NOTE: See your Engine Owner's Manual for information on cold weather starting.

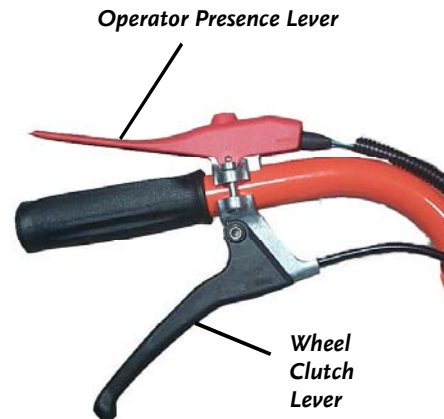

Figure 4

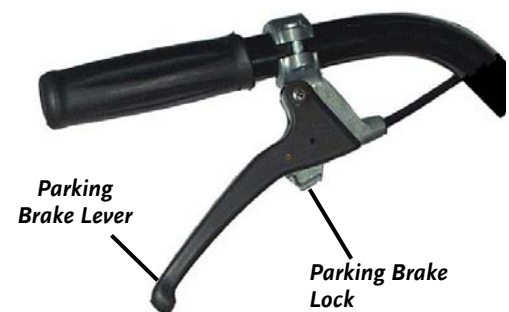

Figure 5

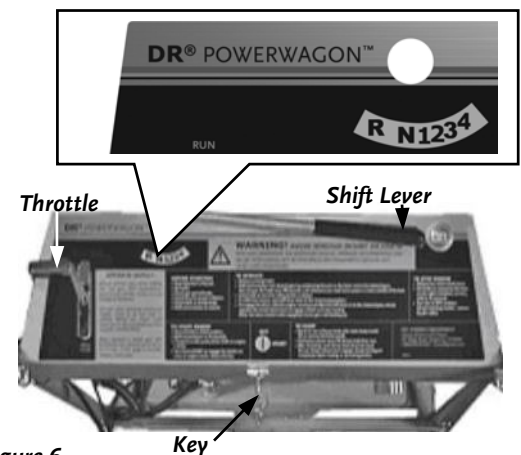

Figure 6

Manual Recoil Starting

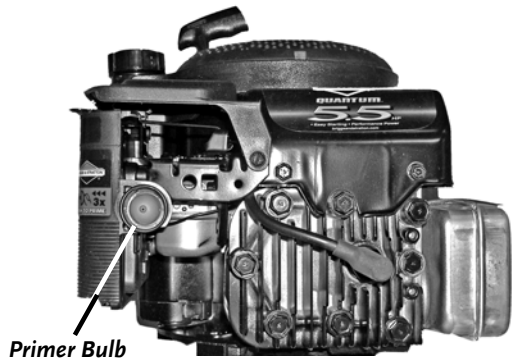

Figure 7

1. Move the Shift Lever to the "N" (Neutral) position (**Figure 6** on page 13).
2. Move the Throttle Lever to the RUN position.
3. If the engine is cold, depress the Primer Bulb three (3) times (**Figure 7**). In cold weather, you may need to depress additional times, being sure that the Bulb inflates between pumps.
4. Turn the Key to the RUN position (**Figure 6** on page 13).
5. Pull the Recoil Pull Handle slowly, until you feel resistance; then pull the Handle with a rapid, full arm stroke to overcome compression and start the engine. Repeat if necessary.
6. After the engine starts, move the Throttle Lever (**Figure 6** on page 13) to the desired Engine speed.

NOTE: See your Engine Owner's Manual for information on cold weather starting.

Operating

! WARNING!

ALWAYS RELEASE THE WHEEL CLUTCH LEVER ON THE LEFT HANDLEBAR WHEN SHIFTING TO AVOID DAMAGING THE GEARS.

The DR POWERWAGON-PREMIER has a four-speed forward transmission and single-speed reverse. Use the lower gears for slower speeds, heavy loads, or more power and the higher gears for transport over smooth terrain. Use 1st gear with loads over 400 lbs. and on slopes. Never use your machine on slopes greater than 20°.

! NOTICE!

WHEN ENGAGING REVERSE GEAR USE EXTRA CAUTION. CHECK YOUR PATH AND FOOTING BEFORE ENGAGING THE WHEEL CLUTCH LEVER.

1. With the Operator Presence Lever depressed (**Figure 4** on page 13), move the Shift Lever to the desired gear.

! WARNING!

SQUEEZING THE WHEEL CLUTCH LEVER RAPIDLY WILL MAKE THE DR POWERWAGON-PREMIER "JUMP" INTO MOTION. SQUEEZE THE CLUTCH LEVER SLOWLY AND EASE THE MACHINE INTO GEAR.

2. Squeeze the Wheel Clutch Lever on the left Handlebar slowly.

Stopping

WARNING!

BE CAREFUL WHEN TRANSPORTING HEAVY LOADS WITH YOUR DR POWERWAGON-PREMIER. IF YOU APPLY THE PARKING BRAKE SUDDENLY, THE LOAD MAY SHIFT AND THE POWERWAGON MAY START TO TIP FORWARD. BRAKE SLOWLY AND TRY TO AVOID OVERLOADING THE MOLDED BED.

1. Release the Wheel Clutch Lever (*Figure 4* on page 13) and move the Throttle to the Idle/Stop position (*Figure 6* on page 13).
2. Set the Parking Brake by squeezing the Parking Brake Lever on the right Handlebar and lifting the Parking Brake Lock (*Figure 5* on page 13).
3. Shift to "N" (Neutral, *Figure 6* on page 13).
4. Turn the Key to the OFF position and remove it for safety.

NOTICE!

IN AN EMERGENCY SITUATION, RELEASING THE OPERATOR PRESENCE LEVER WILL STOP THE MACHINE. AFTER THE MACHINE STOPS, FOLLOW STEPS 2 THROUGH 4 ABOVE.

Operating Tips

- Avoid abrupt start-ups. Always squeeze the Wheel Clutch Lever slowly to avoid bucking, or tipping the DR POWERWAGON-PREMIER.
- When using reverse, check to see that there are no obstacles behind you. Practice backing up in an open area with no load in the DR POWERWAGON-PREMIER.

Loading

WARNING!

THE RECOMMENDED MAXIMUM LOAD LIMIT FOR THE DR POWERWAGON-PREMIER IS 500 LBS. ON LEVEL TERRAIN AND 1ST GEAR AND 400 LBS. ON SLOPES. NEVER OPERATE ON SLOPES GREATER THAN 20°. PLACING MORE WEIGHT IN THE BED MAY BE DANGEROUS TO THE OPERATOR, AND CAN PERMANENTLY DAMAGE THE UNIT.

- When loading your DR POWERWAGON-PREMIER keep in mind the bulk and weight of what you will be hauling, and the terrain you will be crossing.
- Keep the load balanced and secured. Always distribute the load evenly so your DR POWERWAGON-PREMIER will be as stable as possible.
- Don't pile material too high. Divide your load and make several lighter trips. Do not pile heavy loads, such as rocks or gravel, to a height that will make the DR POWERWAGON-PREMIER top-heavy and susceptible to tipping over.
- Be careful going downhill and applying the Parking Brake. Squeeze the Parking Brake Lever very slowly to avoid dumping the load.

Slopes and Uneven Terrain

WARNING!

WHEN OPERATING OVER UNEVEN TERRAIN AND SLOPES, USE EXTREME CAUTION TO ENSURE SOLID AND FIRM FOOTING. MOVE SLOWLY IF THE GROUND IS ROUGH, ESPECIALLY WITH A FULL LOAD. USE 1ST GEAR ON SLOPES WITH A MAXIMUM LOAD OF 400 LBS. NEVER OPERATE ON SLOPES GREATER THAN 20°.



Figure 8

- Never operate the DR POWERWAGON-PREMIER on slopes greater than 20 degrees (**Figure 8**). This is for safety and proper engine operation. Doing so could deprive the engine of oil and cause it to overheat resulting in component damage.
- USE CAUTION: The DR POWERWAGON-PREMIER may become unstable when moving over ruts, bumps, and other depressions.
- On a slope, a heavy load will tend to shift. When using your DR POWERWAGON-PREMIER, keep in mind that loads tend to shift to the downhill side of the dump bed. Secure your load in the bed to limit the shifting of the load on slopes. The higher and heavier the load, the greater the possibility of tipping over. Travel up and down slopes (**Figure 8**) and avoid going across slopes.
- Again, be especially careful with full loads. A good rule of thumb: the steeper the hill, the lighter, and lower your load should be.
- When going downhill, keep a firm grip on the Handlebars and push down slightly. Do not apply the Parking Brake abruptly when going downhill.

Dumping

NOTE: For safety reasons, the design of the DR POWERWAGON-PREMIER Bed is NOT to dump automatically once you release the Dump Lever. You must pull the Dump Lever back then lift the back of the Bed to cause it to tip forward.

1. Pull the Dump Lever Handle straight out (**Figure 9**), then pull up on the Bed Handle to dump the load (**Figure 10**).
2. After unloading, push the Bed back down into place by hand.

Dump Lever Handle

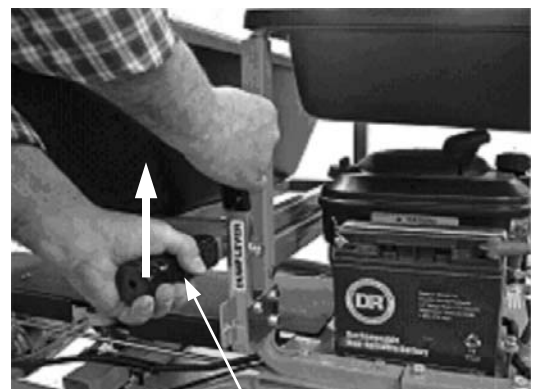

Figure 9

! NOTICE!

BE SURE THE DUMP LEVER LATCHES SECURELY.

NOTE: The Bed of the DR POWERWAGON-PREMIER is balanced so you can dump the load with minimal effort. If you are carrying a very heavy load, you may not be able to lift the Bed to dump it when you release the Latch Lever. In this case, you will need to manually remove part of the load from the back of the Bed, until the load is light enough to allow the Bed to tip forward when you lift the Bed Handle.



Bed Handle

Figure 10

MAINTAINING THE DR POWERWAGON-PREMIER

Regular maintenance is the way to ensure the best performance and long life of your machine. Please refer to this manual and the Engine Owner's Manual for maintenance procedures. Service intervals listed in the checklist below supersede those listed in the Engine Owner's Manual.

WARNING!

WHEN PERFORMING ANY MAINTENANCE, YOU MUST FIRST SHUT OFF THE ENGINE, SET THE PARKING BRAKE, WAIT FIVE (5) MINUTES TO ALLOW PARTS TO COOL AND DISCONNECT THE SPARK PLUG WIRE, KEEPING IT AWAY FROM THE SPARK PLUG.

Regular Maintenance Checklist

NOTE: Consider the service intervals shown as maximum under normal operating conditions. Increase the frequencies under extremely dirty or dusty conditions.

Procedure	Before Each Use	Every 25 Hours	Every 100 Hours
Check Operator Presence Lever	▲		
Check Engine Oil Level	▲		
Check General Equipment Condition	▲		
Lubricate Grease Fittings		▲	
Check Tire Pressure	▲		
Clean Air Filter & Precleaner		▲	
Change Engine Oil	1 st time 5 hours	▲	
Check Parking Brake Adjustment		▲	
Check Belt Tension & Condition		▲	
Check Cable Connections		▲	
Clean Engine Exterior & Cooling Fins		▲	
Check Battery Voltage		▲	
Replace Spark Plug			▲
Replace Air Filter & Precleaner			▲

Battery Care

Proper care can extend the life of a Battery. Follow these recommendations to ensure your Battery's best performance and long life:

- Do not allow the Battery charge to get too low. If the machine is not used, charge the Battery every 4 – 6 weeks. Operate the Engine for at least 45 minutes to maintain proper Battery charge.
- Store an unused Battery in a dry area that does not freeze.
- Do not charge an already charged Battery. In theory, you cannot overcharge our Battery with a trickle charger; however, when a Battery is fully charged and the charger is still on, it generates heat that could be harmful to the Battery. A fully charged Battery will read 12V-13.2V with a voltmeter.
- Do not continue to crank the Engine when the Battery charge is low.

Charging the Battery

Operate the engine for at least 45 minutes to maintain proper battery charge. If the battery loses its charge, you will need to use a trickle charger (like the DR Battery Charger) to recharge it. The charger should have an output of 12 volts at no more than 2 amps.

- At 1 amp, the Battery may need charging for as long as 48 hours.
- At 2 amps, the Battery may need charging for as long as 24 hours.

NOTE: *Using the Recoil Starter and then running the Engine will not recharge a dead or significantly discharged Battery.*

To connect a battery charger to your DR POWERWAGON-PREMIER, follow the steps listed below.

1. Detach the two (2) Battery cables going to the Battery on your machine.
2. Attach the red (+) Battery Charger Wire to the red (+) Battery tab, and the black (-) Battery Charger Wire to the black (-) Battery tab.
3. Plug the Battery Charger into an outlet.

NOTE: *We have modified the Battery Wire Clips and Extension Tabs to accommodate different wiring connections. If you need to adapt your Charger to your equipment, please call one of our Technical Support Representatives for more information.*

NOTICE!

WHEN YOU ARE FINISHED CHARGING THE BATTERY, DISCONNECT THE CHARGER FROM THE OUTLET FIRST, THEN DISCONNECT THE BATTERY CHARGER WIRES FROM THE BATTERY. IF YOU LEAVE THE BATTERY CHARGER WIRES CONNECTED TO THE BATTERY, THE BATTERY WILL DISCHARGE ITSELF BACK INTO THE CHARGER.

Lubrication

WARNING!

WHEN PERFORMING ANY MAINTENANCE, YOU MUST FIRST SHUT OFF THE ENGINE, SET THE PARKING BRAKE, WAIT FIVE (5) MINUTES TO ALLOW PARTS TO COOL AND DISCONNECT THE SPARK PLUG WIRE, KEEPING IT AWAY FROM THE SPARK PLUG.

Your DR POWERWAGON-PREMIER was lubricated at the Factory. The transmission is factory sealed and lubricated for life with 16 ounces of 90-weight gear oil. The operator needs only to provide Engine lubrication, wheel, and cable lubrication.

Supplies Needed:

- SAE 30 Oil
- #2 Lithium Grease

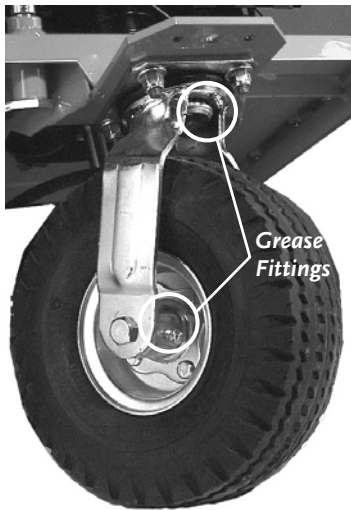

Figure 11



Figure 12

1. There are two (2) Grease Fittings on the Swivel Wheel, one (1) at the top front of the Wheel Bracket, and one (1) toward the center of the Wheel (**Figure 11**). Grease these two (2) fittings with #2 lithium grease to keep the Wheel spinning freely, at least every 25 hours of operation, per the Maintenance Checklist on page 18.
2. Using SAE 30 Oil, lubricate the Parking Brake Lever Cable at the Operator's end and the Wheel Clutch Lever Cable at both ends (**Figures 12 and 13**). Operate the Levers to work the lubricant into the Cables.
3. Lubricate the Key Switch with SAE 30 Oil.

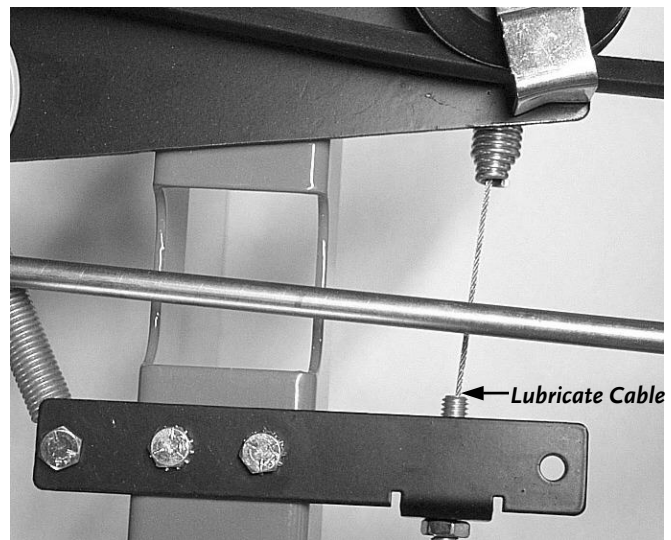

Figure 13

Changing the Engine Oil

WARNING!

WHEN PERFORMING ANY MAINTENANCE, YOU MUST FIRST SHUT OFF THE ENGINE, SET THE PARKING BRAKE, WAIT FIVE (5) MINUTES TO ALLOW PARTS TO COOL AND DISCONNECT THE SPARK PLUG WIRE, KEEPING IT AWAY FROM THE SPARK PLUG.

Tools & Supplies Recommended:

- 3/8" Ratchet and extension
- SAE 30 High Detergent (HD) Oil (for winter use, use SAE 5W – 30W)
- Suitable container for the old oil
- Rag or cloth
- Liquid Vac Oil Drainer, item # 16145 (Optional Accessory, sold separately)

1. Using a 3/8" Ratchet and extension, remove the Oil Drain Plug from the bottom of the Engine (**Figure 14**) and drain the oil.
2. Replace the Plug and refill the oil to the level indicated on the Dipstick. Do not overfill. Refer to the Adding Oil and Gasoline section on page 11.

Alternate Method

1. Remove the Oil Fill Cap and vacuum the oil from the Engine through the Oil Fill Tube using the recommended Oil Drainer.

NOTE: *If you will not be reusing the oil, be sure to use environmentally safe disposal procedures in the disposing of the used oil.*

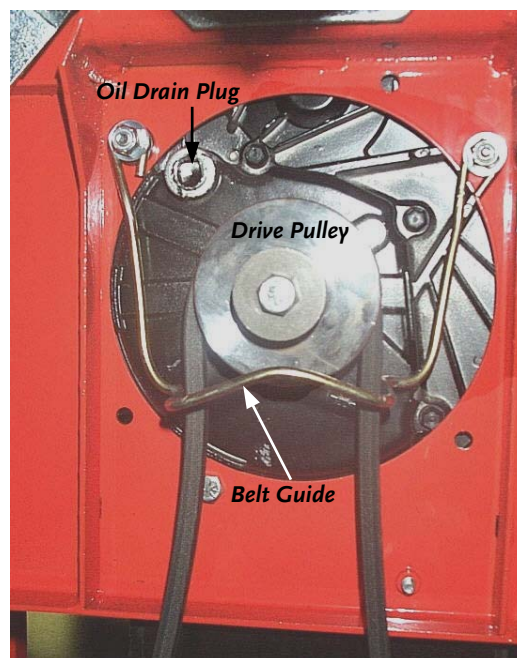

Figure 14

Removing and Replacing the Belt

WARNING!

WHEN PERFORMING ANY MAINTENANCE, YOU MUST FIRST SHUT OFF THE ENGINE, SET THE PARKING BRAKE, WAIT FIVE (5) MINUTES TO ALLOW PARTS TO COOL AND DISCONNECT THE SPARK PLUG WIRE, KEEPING IT AWAY FROM THE SPARK PLUG.

NOTICE!

USE ONLY DR BELTS ON YOUR MACHINE. THEY HAVE BEEN THOROUGHLY TESTED AND PROVEN FOR MANY HOURS OF USE.

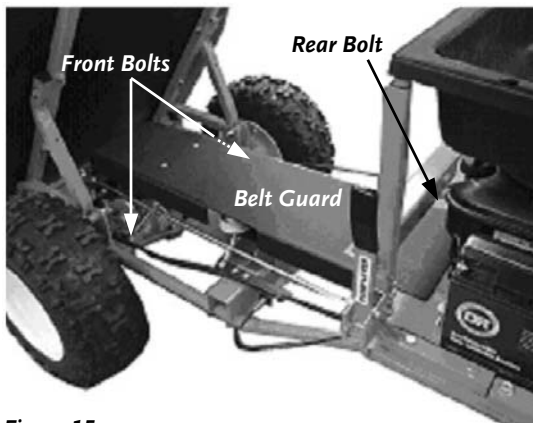

Figure 15

Tools Needed:

- 7/16" Socket and extension
- 9/16" Socket
- 3/8" Wrench
- Phillips Screwdriver

1. Position the machine on a level surface and set the Parking Brake.
2. Tip the Bed forward (**Figures 9 and 10** on page 17).
3. Remove the Belt Guard by removing the two (2) Bolts at the front using a Phillips screwdriver and 3/8" wrench. Remove the single Bolt at the rear using a 7/16" socket (**Figure 15**).
4. Loosen the Belt Guide Bolts using a 9/16" socket (**Figure 16**).
5. Pull on the Idler Arm and Spring to lessen the tension on the Belt and slide the Belt from the Idler Arm and Clutch Pulley (**Figure 16**).
6. Remove the Belt from the Transmission Pulley at the front of the machine (**Figure 17** on page 23).
7. Remove the Belt from the Drive Pulley under the Engine (**Figure 14** on page 21).
8. Install the new Belt on the Drive Pulley first, then the Transmission Pulley and then the Idler and Clutch Pulleys. Make sure the new Belt is INSIDE the Belt Guide (**Figure 14** on page 21).

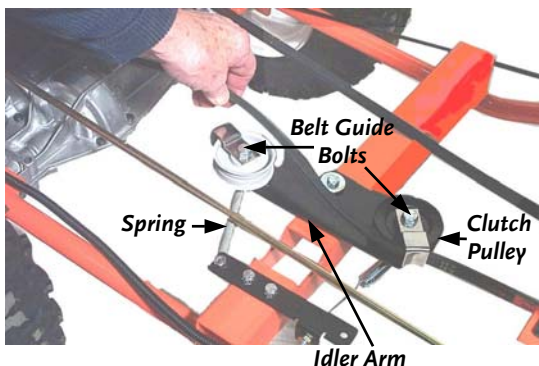

Figure 16

Remove Belt from Transmission Pulley



Figure 17

9. Squeeze the Wheel Clutch Lever to engage the Clutch. The Belt Guides should be perpendicular to and not touching the Belt (**Figure 18**). With the Wheel Clutch engaged, adjust the Guides as necessary and tighten the Guide Bolts (**Figure 16**) with the 9/16" socket.

NOTE: When the Wheel Clutch Lever is released (disengaged), the Belt Guides will just touch the Belt (**Figure 19**) to prevent the DR POWERWAGON-PREMIER from "creeping".

Guides are perpendicular to, and not touching the Belt with Clutch Engaged.

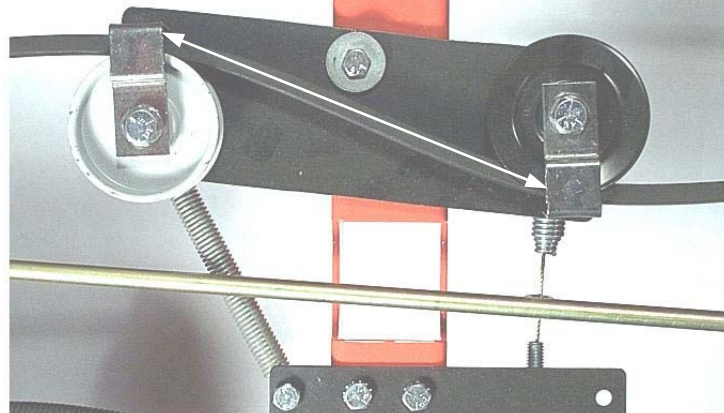

Figure 18

Guides are just touching the Belt with Clutch Disengaged.

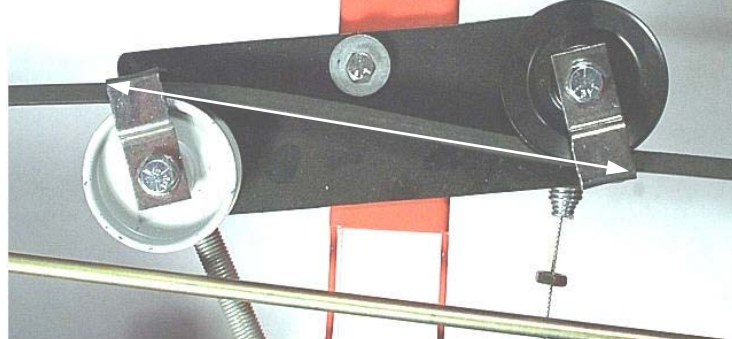

Figure 19

Removing and Replacing the Front Wheels

WARNING!

WHEN PERFORMING ANY MAINTENANCE, YOU MUST FIRST SHUT OFF THE ENGINE, SET THE PARKING BRAKE, WAIT FIVE (5) MINUTES TO ALLOW PARTS TO COOL AND DISCONNECT THE SPARK PLUG WIRE, KEEPING IT AWAY FROM THE SPARK PLUG.

Tools Needed:

- Blade Screwdriver
- Eye protection
- Pliers

1. Block the machine up off the ground so that the Front Wheels spin freely.
2. Rotate the Tire so the Key slot is upward, then pop off the Wheel Lock Ring with the Screwdriver (**Figure 20**) and save it. Remove the Washer and slide the Wheel off.
3. To replace the Wheel, leave the Key in place (if possible) and slide the Wheel back on. If the Key comes out when you take the Wheel off, put the Wheel back on and rotate it until the Key slots line up. Slide the Key back in place and reinstall the Washer and Wheel Lock Ring.

Tip: Pliers will help seat the Lock Ring.

NOTE: When replacing the Wheel Lock Ring, make sure the center of the Wheel Lock Ring is opposite the Key.

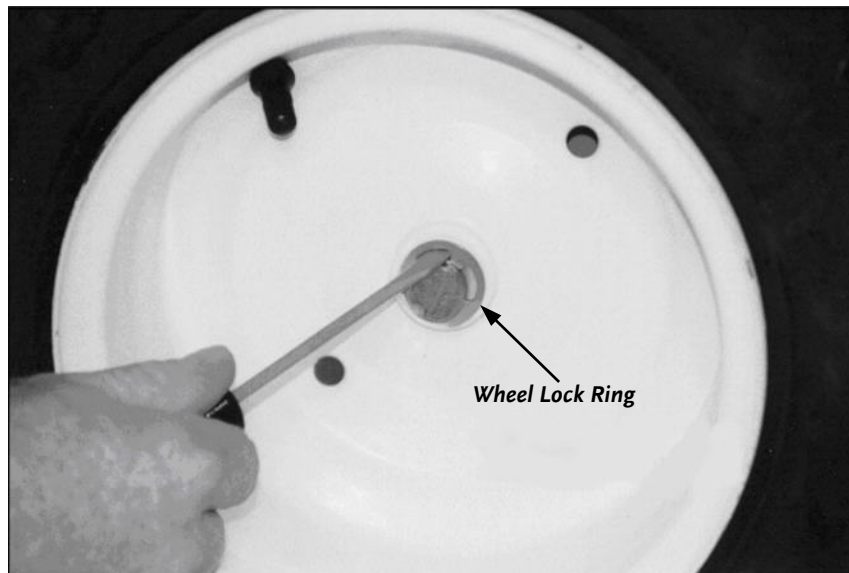

Figure 20

Adjusting the Parking Brake

NOTE: If your DR POWERWAGON-PREMIER rolls on slopes when the Parking Brake is set, or if you can't get the Parking Brake to set, it needs to be adjusted (**Figure 21**).

! WARNING!

WHEN PERFORMING ANY MAINTENANCE, YOU MUST FIRST SHUT OFF THE ENGINE, SET THE PARKING BRAKE, WAIT FIVE (5) MINUTES TO ALLOW PARTS TO COOL AND DISCONNECT THE SPARK PLUG WIRE, KEEPING IT AWAY FROM THE SPARK PLUG.

Tool Needed:

- 1/2" Wrench or Socket

1. With the machine on a level surface, set the Parking Brake.
2. Put the Transmission in "N" (Neutral).
3. Test the Parking Brake by trying to roll the machine. It should not move in either direction with the Parking Brake set.
4. If it does move, turn the Brake Adjustment Nut on the Transaxle (**Figure 21**) 1/4 turn clockwise with a 1/2" Wrench to tighten the Parking Brake. Test the Parking Brake as described in Steps 1-3. Repeat the adjustment if necessary.
5. If you can't get the Parking Brake to release, turn the Brake Adjustment Nut (**Figure 21**) on the Transaxle 1/4 turn counterclockwise with a 1/2" Wrench to loosen the Parking Brake. Test the Parking Brake, as described in Steps 1-3. Repeat the adjustment if necessary.

NOTE: Turn the Brake Adjustment Nut only 1/4 turn at a time, and then test the Parking Brake to see if the adjustment worked. If needed, adjust the Nut another 1/4 turn and test again.

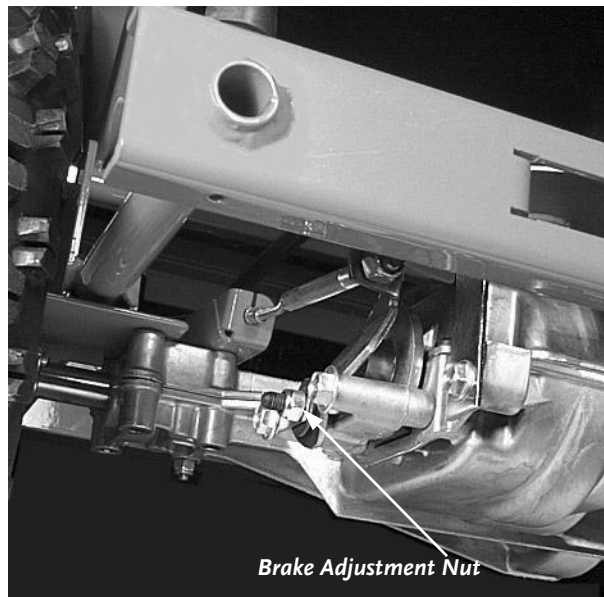

Figure 21

Parking Brake Cable Adjustment

NOTE: The Parking Brake Cable, located on the right side of the machine, is factory set (**Figure 22**). If you think the Parking Brake Cable needs adjustment, you may actually need to replace the Parking Brake Pads. See below.

Changing the Parking Brake Pads

WARNING!

WHEN PERFORMING ANY MAINTENANCE, YOU MUST FIRST SHUT OFF THE ENGINE, SET THE PARKING BRAKE, WAIT FIVE (5) MINUTES TO ALLOW PARTS TO COOL AND DISCONNECT THE SPARK PLUG WIRE, KEEPING IT AWAY FROM THE SPARK PLUG.

NOTE: If your DR POWERWAGON-PREMIER rolls on slopes when the Parking Brake is set, and you have tried adjusting the Parking Brake, the Parking Brake Pads may need replacement.



Figure 22

Tools & Supplies Needed:

- 1/2" Wrench or Socket
- Mat or container for loose parts

NOTE: You may want to remove the Wheel to provide easier access to the Parking Brake area. See page 24.

1. Find a level area to work. The Parking Brake should NOT be engaged. Chock the Wheels so the machine cannot move.
2. Locate the Parking Brake Caliper at the right front of the machine (**Figure 23**). Remove the two (2) Caliper Bolts holding the Parking Brake Caliper with a 1/2" Wrench, and then carefully remove the Caliper.

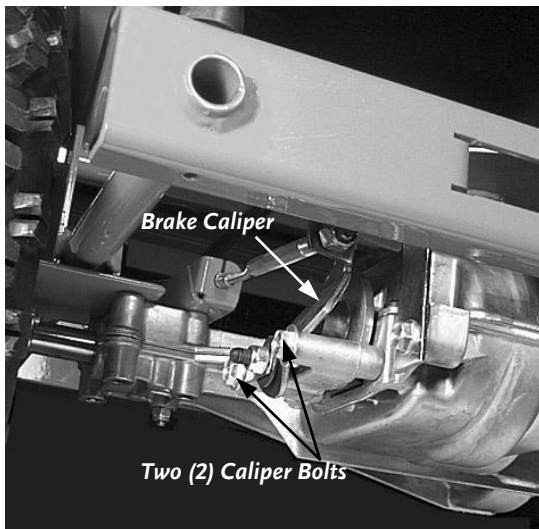

Figure 23

NOTE: The Caliper contains four (4) small parts: the Brake Pad, the Backing Plate, and two (2) small Actuator Pins (**Figures 24 and 25**). As you let the Caliper hang from its attaching hardware, keep track of these parts as they could fall out. Clean away any debris from these parts and the inside of the Caliper.

3. Pull the Brake Disc off the keyed Shaft (**Figure 24**) being careful not to lose the Shaft Key.
4. Remove the old Brake Pad from behind the Disc and replace it with a new Brake Pad, then reinstall the Brake Disc.
5. Replace the Caliper Housing and its parts: two (2) Actuator Pins, the Backing Plate, and the second Brake Pad (**Figure 25**). Make sure the Brake Arm Assembly is in the upright position and the recessed cutout on the Caliper is facing up with the Plate to the rear. Be sure that the Parking Brake Lever is pointing up (**Figure 23** on page 26). Reinstall the two (2) Caliper Bolts and be careful not to over tighten them.
6. Test the Parking Brake. With the machine on a level surface, set the Parking Brake and put the machine in "N" (Neutral). If the Parking Brake does not engage or hold, tighten the Parking Brake Adjustment Nut 1/4 turn with a 1/2" wrench. See "Adjusting the Parking Brake" on page 25.

NOTE: Check the Parking Brake periodically and adjust accordingly.

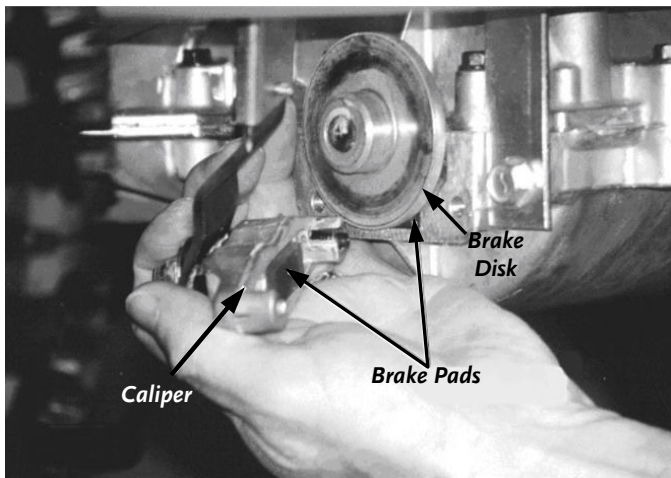

Figure 24

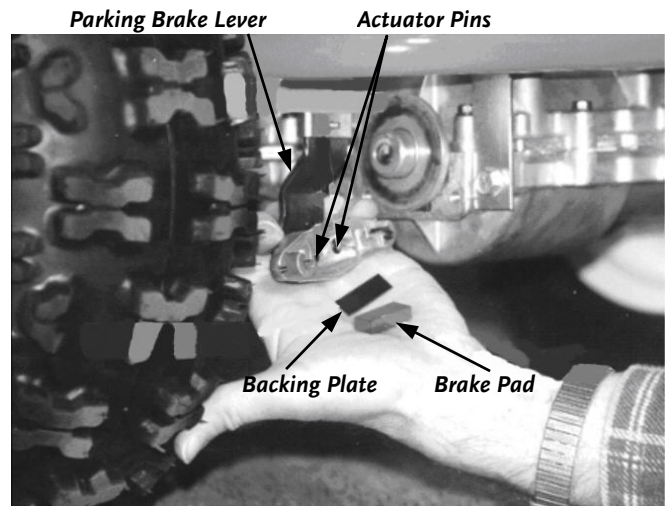

Figure 25

Replacing the Throttle Cable

! WARNING!

WHEN PERFORMING ANY MAINTENANCE, YOU MUST FIRST SHUT OFF THE ENGINE, SET THE PARKING BRAKE, WAIT FIVE (5) MINUTES TO ALLOW PARTS TO COOL AND DISCONNECT THE SPARK PLUG WIRE, KEEPING IT AWAY FROM THE SPARK PLUG.

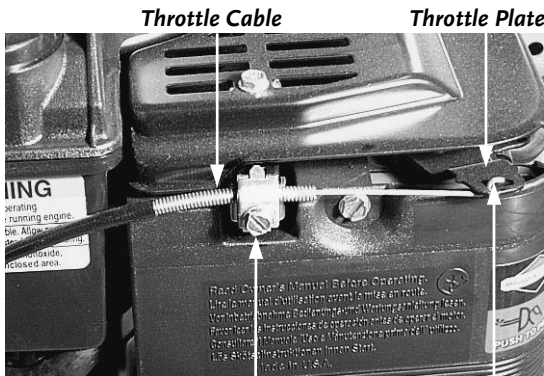

Figure 26 Throttle Cable Clamp "Z"-Bend

NOTE: The Throttle Cable is set at the factory, and generally, no service is required. The Cable is supplied as a complete assembly with the Handle already attached (Figure 27). However, when replacing the Throttle Cable it is important to follow these steps:

Tools Needed:

- 1/4" Socket
- Blade Screwdriver



Throttle Assembly (underside)

Figure 27

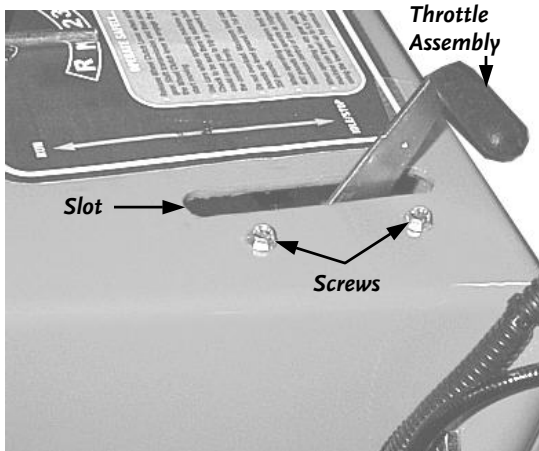

Figure 28

1. Loosen the Screw on the Throttle Cable Clamp with a Screwdriver so the Throttle Cable can slide below it. It is not necessary to remove the Clamp (Figure 26).
2. Remove the "Z"-bend end of the Cable from the Throttle Plate (Figure 26).
3. Remove the two (2) Screws holding the Throttle Assembly (Figure 27) to the Control Panel with a 1/4" Socket or Screwdriver (Figure 28).
4. Tilt and slide the Throttle Assembly down through the Slot in the Control Panel (Figure 28).
5. Tilt and place the Handle of the new Throttle Assembly up through the Slot in the Control Panel and fasten with two (2) Screws. Position the Throttle Handle to IDLE/STOP.
6. Route the Throttle Cable the same as the old Cable, being careful not to bend or kink the Cable.
7. Place the Z-bend end of the Throttle Cable into the small hole in the Throttle Plate on the Engine. The Throttle Plate is a black Tab that protrudes from the Engine below the plastic Air Filter. It has two (2) holes, and the Cable goes into the smaller hole. Place the Throttle Cable Sheath under the Cable Clamp (Figure 26).
8. Make sure that the Throttle Plate is all the way back to the Stop position. It will normally retract to this position.

9. Tighten the Throttle Cable Clamp Screw making sure that the Throttle Handle is still in the IDLE/STOP position. The Throttle Cable should have very little or no tension between the Cable Clamp and the Throttle Plate.

 **NOTICE!**

IF YOU CLAMP THE CABLE WITH TOO MUCH TENSION BETWEEN THE CABLE CLAMP AND THE THROTTLE PLATE, THE ENGINE WILL NOT RETURN TO IDLE PROPERLY.

10. Start the Engine and check the operation of the machine. The DR POWERWAGON-PREMIER should idle smoothly, but should not move while idling, and should not jump after shifting into gear.

Adjusting the Shift Lever

If you are unable to shift into Reverse or 4th gear, the Shift Lever and Tie Rod need to be adjusted.

! WARNING!

WHEN PERFORMING ANY MAINTENANCE, YOU MUST FIRST SHUT OFF THE ENGINE, SET THE PARKING BRAKE, WAIT FIVE (5) MINUTES TO ALLOW PARTS TO COOL AND DISCONNECT THE SPARK PLUG WIRE, KEEPING IT AWAY FROM THE SPARK PLUG.



Figure 29

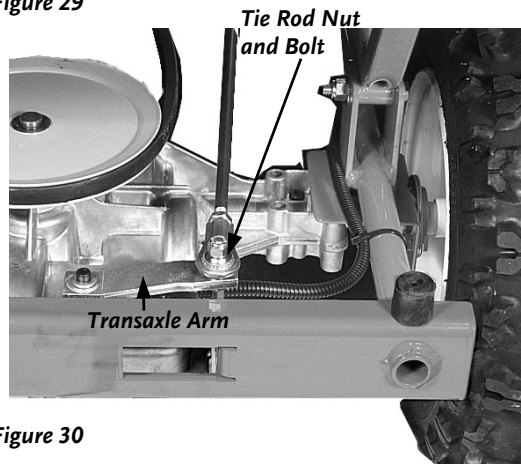

Figure 30

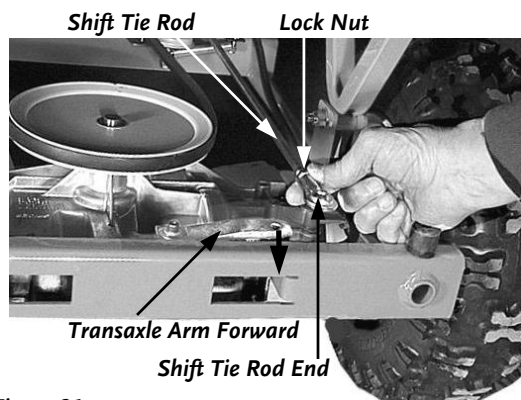

Figure 31

Tools Needed:

- 1/2" Box Wrench or Socket
- 1/2" Box or Open-end Wrench
- 9/16" Box or Open-end Wrench

1. Move the Shift Lever into the Reverse position (**Figure 29**).
2. Loosen and remove the Tie Rod Nut and Bolt from the Transaxle Arm with 1/2" wrenches (**Figure 30**). Remove the Tie Rod from the Transaxle Arm.
3. Fully extend the Transaxle Arm toward the front of the machine. This will put the Transmission into Reverse gear (**Figure 31**).
4. Loosen the Lock Nut on the Shift Tie Rod end with a 9/16" Open-end Wrench (**Figure 31**) and turn the Tie Rod end, clockwise to shorten the Tie Rod, and counterclockwise to lengthen it.
5. Adjust the Tie Rod length until the Shift Indicator points to Reverse when you reinstall the Tie Rod end onto the Transaxle Arm.
6. When the adjustment is complete, re-tighten the Lock Nut against the Ball end.
7. Place the Tie Rod back on the Transaxle Arm, insert the Bolt, and re-tighten the Nut.

This should now enable you to use the full range of gears.

Adjusting the Wheel Clutch

! WARNING!

WHEN PERFORMING ANY MAINTENANCE, YOU MUST FIRST SHUT OFF THE ENGINE, SET THE PARKING BRAKE, WAIT FIVE (5) MINUTES TO ALLOW PARTS TO COOL AND DISCONNECT THE SPARK PLUG WIRE, KEEPING IT AWAY FROM THE SPARK PLUG.

NOTE: When properly adjusted, tension on the Wheel Clutch Lever should increase when the Lever is about parallel to (almost touching) the Handlebar Grip.

Tools Needed:

- (2) 1/2" Wrenches
1. Raise the Dump Bed to expose the Wheel Clutch Adjustment Bracket (**Figure 32**).
 2. If the Wheel Clutch Lever contacts the Handlebar without engaging the Wheel, tighten the Clutch by loosening the Nut on the underside (threaded) of the Bracket by 1/8" to 1/4", and tightening the Nut on the outside against the Bracket. Check the tension on the Wheel Clutch Lever and repeat the adjustment as needed.
 3. If the Wheels engage before you activate the Lever or the Lever does not contact the Handlebar when activated, reverse the adjustment in step 2.

! WARNING!

IF YOU OVER TIGHTEN THE CLUTCH, THE MACHINE MAY LURCH FORWARD WHEN SHIFTING INTO GEAR. USE CAUTION WHEN SHIFTING INTO GEAR.

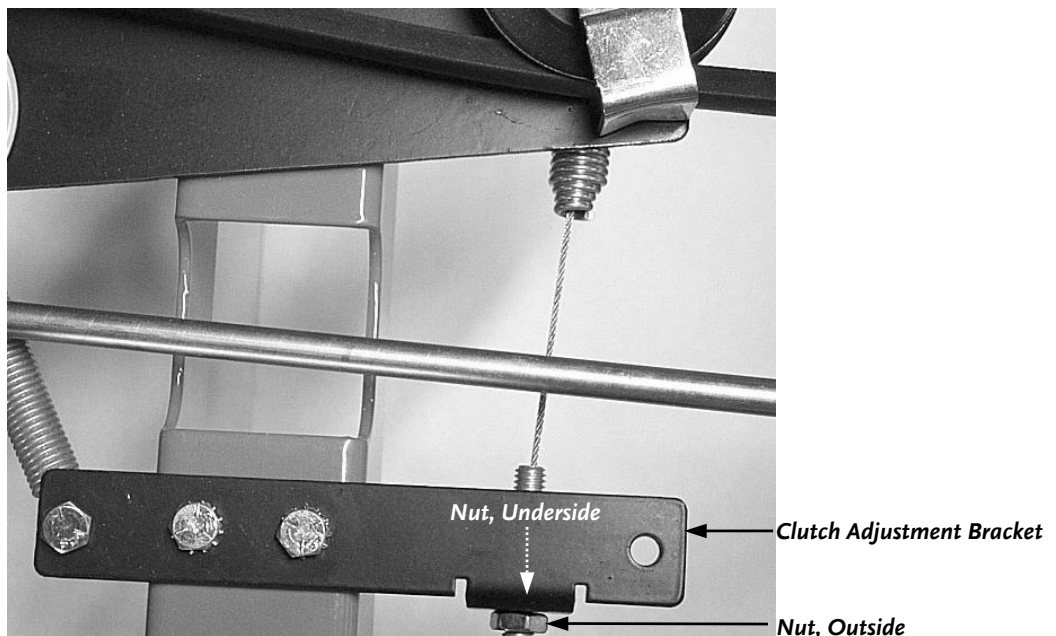

Figure 32

End of Season and Storage

WARNING!

WHEN PERFORMING ANY MAINTENANCE, YOU MUST FIRST SHUT OFF THE ENGINE, SET THE PARKING BRAKE, WAIT FIVE (5) MINUTES TO ALLOW PARTS TO COOL AND DISCONNECT THE SPARK PLUG WIRE, KEEPING IT AWAY FROM THE SPARK PLUG.

NOTE: Please refer to the Engine Owner's Manual for Engine-specific procedures.

- Change the Oil; this will help to eliminate sludge and acids in the Engine.
- If your DR POWERWAGON-PREMIER will be idle for more than 30 days, we recommend using a gas stabilizer. This will prevent sediment from gumming up the carburetor. If there is dirt or moisture in the gas or tank, remove it by draining the tank. Completely fill the tank with fresh, unleaded gas and add the appropriate amount of stabilizer or gasoline additive. Run the Engine for a short time to allow the additive to circulate.
- Remove the Spark Plug and pour about 1 ounce of motor Oil into the Cylinder Hole. Replace the Plug and pull the Recoil Starter Rope until you feel strong resistance. This will coat the Piston and seat the Valves to prevent moisture buildup.
- Clean and replace the Air Filter(s) as required.
- Clean dirt and debris from the Cylinder Head cooling fins, Carburetor Linkage, Blower Housing, Rotating Screen, and Muffler area of the Engine.
- Check to make sure the Operator Controls are moving freely. Lubricate the Throttle Lever, Parking Brake Lever, and Key Switch with SAE 30 Oil if necessary. See page 20.
- You should remove the Battery and keep it in a cool, dry place when the DR POWERWAGON-PREMIER is in storage. We suggest charging the Battery every 4 to 6 weeks while the DR is stored and again when you are ready to start the new season. This will help the Battery maintain its charge all season. See page 19.

Recycling a Used Battery

NOTICE!

PLEASE DISPOSE OF USED BATTERIES RESPONSIBLY, ACCORDING TO YOUR LOCAL HAZARDOUS MATERIALS REGULATIONS. NEVER THROW AWAY USED BATTERIES IN YOUR HOUSEHOLD TRASH.

Please dispose of your used batteries responsibly by recycling them. Call your local Solid Waste Management District or your local waste handler to locate the collection site nearest you. Some collection sites recycle batteries year-round; others collect them periodically.

You can also visit the Website of Earth 911 for more information (www.earth911.org). Once there, click the Municipal HHW link under Hazardous Household Waste, and enter your zip code. The site lists recycling centers located near you.

For a fee, you can recycle your batteries with the International Metals Reclamation Company. Visit them at www.inmetco.com and click Services, then click Battery Recycling; or contact them at:

INMETCO
PO Box 720
245 Portersville Road
Ellwood City, PA 16117
(724) 758-2800; fax (724) 758-2845

To learn more about hazardous waste recycling, visit the Website for Battery Council International (www.batterycouncil.org) or for the Environmental Protection Agency (www.epa.gov).

TROUBLESHOOTING

Most problems are easy to fix. Consult the Troubleshooting Table for common problems and their solutions. If you continue to have trouble, call a Technical Support Representative at Country Home Products.

Troubleshooting Table



WARNING!

WHEN PERFORMING ANY MAINTENANCE, YOU MUST FIRST SHUT OFF THE ENGINE, SET THE PARKING BRAKE, WAIT FIVE (5) MINUTES TO ALLOW PARTS TO COOL AND DISCONNECT THE SPARK PLUG WIRE, KEEPING IT AWAY FROM THE SPARK PLUG.

SYMPTOM	POSSIBLE CAUSE
<i>Recoil will not pull out or is difficult to pull.</i>	<ul style="list-style-type: none"> ⇒ Check the Engine oil level; the Engine may be seized. ⇒ There may be an oil compression lock in the cylinder. Take out the Spark Plug; hold a rag over the Spark Plug hole and pull the Recoil Cord several times to blow out any oil in the cylinder. Wipe off the Spark Plug and reinstall it. ⇒ Try to turn the Engine pulley by hand, with the Spark Plug wire off. If it turns, the Recoil is broken or jammed. Call 1-800-DR-OWNER (376-9637) for assistance.
<p><i>The Engine will not start manually.</i></p> <p><i>(Please refer to the Engine Owner's Manual for Engine-specific procedures.)</i></p>	<ul style="list-style-type: none"> ⇒ Check that the Key is in the RUN Position. ⇒ Check that the Spark Plug wire is attached. ⇒ Check the Operator Presence Switch connection beneath the Panel at the Key Switch. ⇒ Check the Operator Presence Switch connection at the Engine. ⇒ Check the oil and gas level. See page 11. ⇒ The gas may be old, change it. Use a fuel stabilizer if you keep gas longer than one month. ⇒ Check the Throttle adjustment and travel. ⇒ The Spark Plug may be dirty or cracked, change it. ⇒ If the Spark Plug is oily, leave it out, hold a rag over the Plug hole and pull the Recoil cord several times to blow out any oil in the cylinder, then wipe off the Plug and reinsert it. ⇒ The Air Filter may be dirty, change it following the procedure in the Engine Owner's Manual. ⇒ If your Engine still won't start, call 1-800-DR-OWNER (376-9637) for assistance.

! WARNING!

WHEN PERFORMING ANY MAINTENANCE, YOU MUST FIRST SHUT OFF THE ENGINE, WAIT FIVE (5) MINUTES TO ALLOW PARTS TO COOL AND DISCONNECT THE SPARK PLUG WIRE, KEEPING IT AWAY FROM THE SPARK PLUG.

SYMPTOM	POSSIBLE CAUSE
<p><i>The Engine will not start using Electric-Start.</i></p> <p><i>(Please refer to the Engine Owner's Manual for Engine-specific procedures.)</i></p>	<ul style="list-style-type: none"> ⇒ Check all the items under the section called Electric-Starting on page 13. ⇒ Check the previous section (<i>The Engine will not start manually.</i>) on page 33 for possible causes. ⇒ Check the wire connections—especially the ground connection, the large black wire coming from the Battery, where it connects to the Engine. ⇒ Check the wire connections to the Solenoid. Disconnect the black Battery ground wire first to avoid sparks. Check to be sure that all of the connections are clean and tight. Reconnect the Battery ground wire. ⇒ Check the ground connection on the Solenoid where it bolts to the frame. Using a Wrench or Socket, tighten the bolts to ensure a good connection to the frame. ⇒ The Battery may not be charged. Check the voltage yourself or at a gas station. If it is low, charge it with a 12-volt, 1 to 2 amp trickle charger. If you do not use your machine for at least 45 minutes at a time, the Battery may need to be periodically charged. See the Battery Care section on page 19. ⇒ If the Battery is charged and your DR POWERWAGON-PREMIER still will not start, call 1-800-DR-OWNER (376-9637) for assistance.
<p><i>The Engine lacks power or is not running smoothly.</i></p> <p><i>(Please refer to the Engine Owner's Manual for Engine-specific procedures.)</i></p>	<ul style="list-style-type: none"> ⇒ Check the Throttle travel and adjustment. ⇒ The Air Filter may be dirty, change it following the procedure in the Engine Owner's Manual. ⇒ The Spark Plug may be dirty or cracked, change it. ⇒ If the Spark Plug is oily, leave it out, hold a rag over the Plug hole and pull the Recoil cord several times to blow out any oil in the cylinder, then wipe off the Plug and reinsert it. ⇒ The gas may be old, change it. Use a fuel stabilizer if you keep gas longer than one month. ⇒ The Engine may not have the right amount of clean oil. If it is dirty, change it following the procedure on page 21. ⇒ If the Engine still lacks power, call 1-800-DR-OWNER (376-9637) for assistance.
<p><i>Engine smokes.</i></p>	<ul style="list-style-type: none"> ⇒ Check the oil level and adjust as needed. ⇒ You may be operating the machine on too great an incline. See the "Slopes and Uneven Terrain" section on page 16. ⇒ Check the Air Filter and clean or replace if needed. ⇒ You may be using the wrong oil—too light for the temperature. Refer to the Engine Owner's Manual for detailed information. ⇒ Clean the Engine cooling fins and the carburetor housing if they are dirty. ⇒ If the Engine still smokes, call 1-800-DR-OWNER (376-9637) for assistance.

! WARNING!

WHEN PERFORMING ANY MAINTENANCE, YOU MUST FIRST SHUT OFF THE ENGINE, WAIT FIVE (5) MINUTES TO ALLOW PARTS TO COOL AND DISCONNECT THE SPARK PLUG WIRE, KEEPING IT AWAY FROM THE SPARK PLUG.

SYMPTOM	POSSIBLE CAUSE
<i>The Belt frays or rolls over the Pulley.</i>	<ul style="list-style-type: none"> ⇒ There may be a nick in a Pulley groove. Check the Belt for wear and hard spots. File off any nicks on the Pulleys. ⇒ Check the Belt Guide alignment. See pages 22 and 23. ⇒ The Belt may be stretched, replace it.
<i>Machine is hard to get into Reverse.</i>	<ul style="list-style-type: none"> ⇒ The Shift Lever may need adjusting. See page 30.
<i>Wheels pulling left or right.</i>	<ul style="list-style-type: none"> ⇒ Check the tire(s) pressure. See page 10.
<i>Machine lacks traction.</i>	<ul style="list-style-type: none"> ⇒ The load may be uneven in the Bed. The more weight over the Wheels the better the traction. ⇒ Try a lower gear. ⇒ If you are working on rough terrain with Turf tires, you may want to consider the All-Terrain tires. Call 1-800-DR-OWNER (376-9637) for information.
<i>The Wheels will not turn.</i>	<ul style="list-style-type: none"> ⇒ Make sure that the DR POWERWAGON-PREMIER is in gear. ⇒ Check that the Parking Brake is off. ⇒ The Drive Belt may be loose or off the Pulley. See page 22. ⇒ The Drive Belt may be on the wrong side of the Pulley. See page 22. ⇒ If the Wheels still will not turn, call 1-800-DR-OWNER (376-9637) for assistance.

PARTS LISTS, SCHEMATIC DIAGRAMS AND WARRANTY

Parts List - Main Frame Assembly

NOTE: Part numbers listed are available through Country Home Products, Inc.

Ref#	Part#	Description	Ref#	Part#	Description
01	223431	Engine, 6.25 Torque, B&S, e/s, CA	100	150451	Bolt, HCS, 5/16"-18 x 1-3/4"
	223831	Engine, 6.25 Torque, B&S, e/s	101	123361	Bolt, HCS, 5/16"-18 x 1-1/4"
05	104831	Battery, 17 AH, 12 V	102	180281	Spacer, .328" ID, .75" OD, .25" L
06	124511	Clamp, Battery, 7.13"W, 5.5"H	110	111661	Screw, Phillips, Pan, #12 x 1"
07	113051	Pad, battery, 3-5/8" x 2-7/8"	114	160871	Coupling, Shift lever
09	114561	Bolt, HCS, 1/4"-20 x 2"	117	160351	Tie rod, 39.09" Rod & Ball ends
16	109341	Stop, Bumper	123	111921	Spring, e, .500" OD x .067" wire
17	164121	Strip, Bumper 2-1/2"	127	126971	Washer, 1/4" ID x 1" OD, Fender
46	108731	Stop Angle, Flat bed	128	112501	Washer, Lock, 5/16"
49	106381	Key, square, 3/16" x 1-1/2"	131	112581	Wheel, Caster, 4.10"/3.50-4"
51	112411	Washer, Flat, 5/16" USS	136	136601	Leg, Tray Frame
52	112371	Washer, Flat, 10-24" USS	142	180501	Bracket, Idler Arm
53	112381	Washer, Flat, 1/4" USS	143	113071	Pulley, Flat Idler, 2-1/4"
54	164301	Frame, Main	146	144091	Pulley, 2-5/8", V-Belt
61	110301	Handle, Latch	148	108971	Belt, A82, 1/2" x 84"
62	110241	Grip, Latch Handle	154	114921	Bracket, Belt Retainer
63	110451	Housing, Latch	158	112391	Washer, Flat, 3/8" USS
64	111931	Latch Spring, 2-1/4"	164	112111	Cable, Throttle, 36-1/2"
66	111291	Lower Shift Rod w/ Arm	165	160461	Throttle Spring Bracket
78	165391	Anchor, Wheel Drive Cable	167	120891	Spring, Throttle Return
79	110751	Nut, Nylon Lock, 3/8"-16	171	180471	Pulley, 3.0", V-Belt
80	110761	Nut, Nylon Lock, 5/16"-18	172	180791	Guide, Engine Belt
83	110961	Pin, Spring, 3/16" x 1	175	114781	Screw, Pan Head, 10-24 x 5/8"
84	110731	Nut, Nylon Lock, 1/4"-20	176	112461	Nylon Washer, .39" ID x 1" OD
85	110971	Pin, Spring, 3/16" x 1-3/4"	177	109411	Bushing, .265" ID x .375" OD
86	114701	Bolt, HCS, 1/4"-20 x 1/2"	181	180801	Guide, Trans. Belt
87	111531	Bolt, HCS, 3/8"-16 x 2-1/4"	182	180851	Bolt, HCS, 1/4"-20 x 2-3/4"
89	119831	Bolt, HCS, 1/4"-20 x 3/4"	185	180511	Guard, Belt
90	111491	Bolt, HCS, 1/4"-20 x 1"	187	180551	Cable, Wheel Clutch
92	160861	Bolt, HCS, 1/4"-20 x 1-1/4"	188	180871	Clip, Nylon, 3/16" Dia.
93	111481	Bolt, HCS, 1/4"-20 x 1-3/4"	Parts Not Shown		
96	111551	Bolt, HCS, 3/8"-24 x 3/4"	193151	Wire, 6.0", Battery Positive	
97	112481	Washer, Lock, 1/4"	193161	Wire, 6.5", Battery Negative	
99	111591	Bolt, HCS, 5/16"-18 x 2-1/2"			

Schematic - Main Frame Assembly

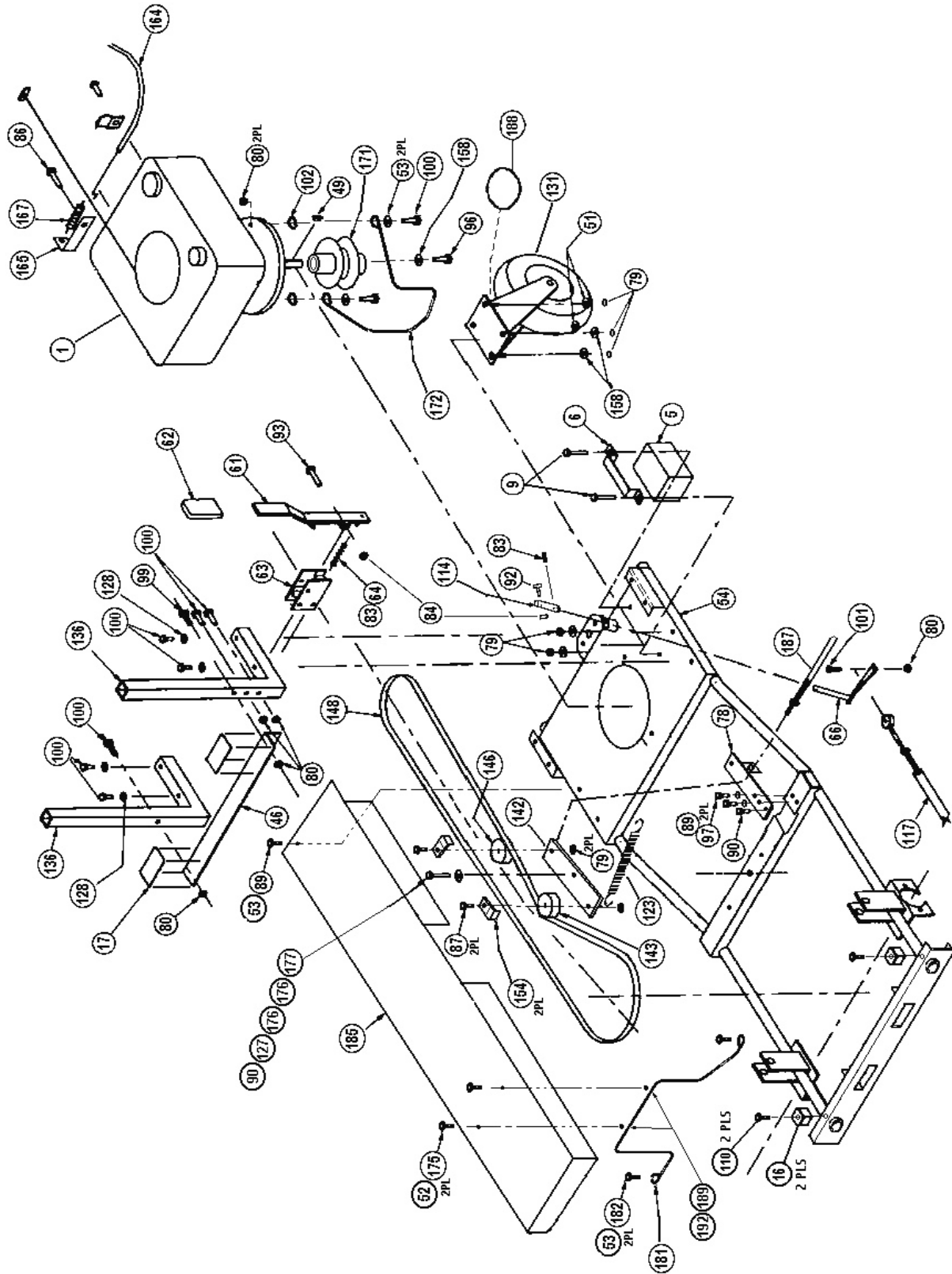

5-05-2006

Parts List - Handlebar/Controls Assembly

NOTE: Part numbers listed are available through Country Home Products, Inc.

<u>Ref#</u>	<u>Part#</u>	<u>Description</u>	<u>Parts Not Shown</u>		
14	187631	Cable, Brake, 73-1/2"	18	112141	Cable Tie, 7-1/2", Black
33	180521	Control Panel	120	112341	Tubing, Shrink
34	180531	Label, Control Panel, Premier	121	111271	Push Rivet, Tool Tray, 1/4"
53	112381	Washer, Flat, 1/4" USS	138	110151	Tool Tray Frame
54	164301	Frame, Main	135	112261	Molded Tool Tray, 15" x 18" x 4-1/2"
55	164311	Handlebar, RH	<u>Safety Labels</u>		
56	164321	Handlebar, LH	124371		Label, American Flag
57	164331	Cross Support, Handle	127811		Label, Warning, Add Oil
80	110761	Nut, Nylon Lock, 5/16"-18	137581		Label, Check Oil
85	110971	Pin, Spring, 3/16" x 1-3/4"	153421		Label, Dump Lever
100	150451	Bolt, HCS, 5/16"-18 x 1-3/4"	153431		Label, Dump Lever Latch
115	108871	Lever, Shift, Upper	153441		Label, Slope Limit
116	110221	Grip, Shift Handle	180451		Label, DR Logo, 4" Dia.
161	188271	Wire Harness w/Adapter	180531		Label, Control Panel
163	112051	Switch, w/Key & Hardware, e/s	186531		Label, ID and Serial Number
164	112111	Cable, Throttle, 36-1/2"			
168	150491	Screw, 8-32 x 1/2"			
170	112441	Washer, 1/2" ID x 3/4" OD			
178	164961	Grip, Plain, 1", Handlebar			
179	164951	Grip, Ergonomic, 1", Handlebar			
180	180691	Lever, Op Presence w/Wire			
183	179231	Screw, M6 x 25mm, Socket Head			
184	165181	Lever, 1", Brake w/Lock			
186	165171	Lever, 1", Wheel Clutch			
187	180551	Cable, Wheel Clutch			
190	120301	Screw, 3/8"-16 x 1-1/2", Trilobe			

Schematic - Handlebar/Controls Assembly

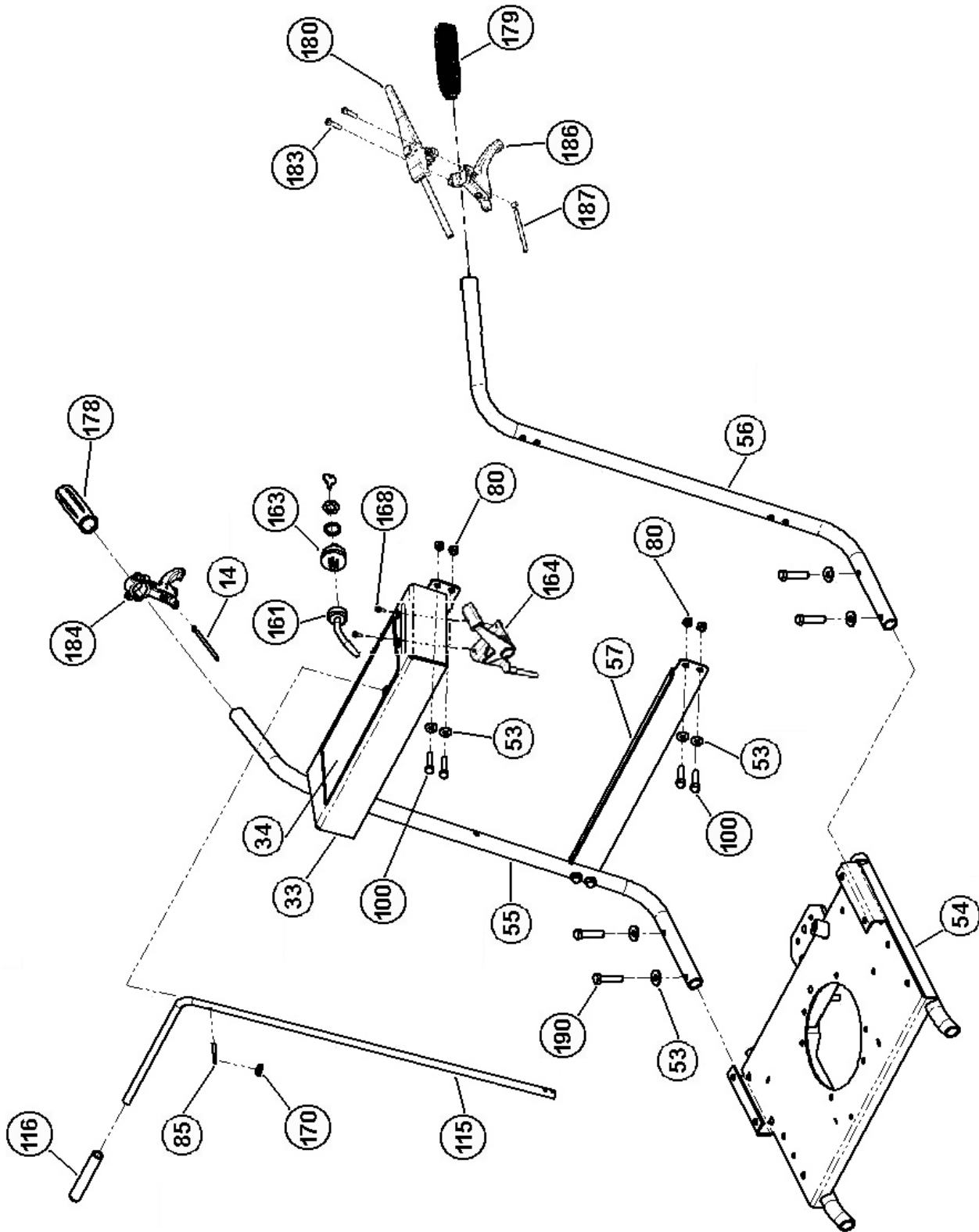

05-15-2006

Parts List - Main Axle Assembly

NOTE: Part numbers listed are available through Country Home Products, Inc.

Ref#	Part#	Description
03	108921	Flange, Ball bearing, 2-Hole
04	152171	Bearing, Ball, 3/4" Bore
12	151181	Bracket, Brake Cable, Orange
14	187631	Cable, Brake, PW Pro, 73-1/2"
37	193121	Wheel, Gray, 16" x 6.50-8, Terr.
49	106381	Key, Square, 3/16" x 1-1/2"
50	160521	Shim, .75" ID, 1.0" OD, .25" L
52	112371	Washer, Flat, 10-24 USS
53	112381	Washer, Flat, 1/4" USS
58	106401	Key, Woodruff, 3/16" x 1/2"
78	165391	Anchor, Wheel Drive Cable
80	110761	Nut, Nylon Lock, 5/16"-18
84	110731	Nut, Nylon Lock, 1/4"-20
91	111501	Screw, 1/4"-28 x 3/4"
100	150451	Bolt, HCS, 5/16"-18 x 1-3/4"
101	123361	Bolt, HCS, 5/16"-18 x 1-1/4"
104	123211	Bolt, HCS, 5/16"-18 x 3/4"
114	160871	Coupling, Shift Lever
117	160351	Tie Rod, 39.09" Rod & Ball Ends
132	111721	Screw, 5/16"-18 x 3/4", Tri-lobe
139	108891	Transaxle, Front Hanger
140	108791	Transaxle, Shift Arm
141	178931	Transaxle, 4 FWD, 1 REV
144	111141	Pulley, 7.0", V-Belt, 5/8" Bore
150	111261	Ring, Retaining, 3/4", type E
182	180851	Bolt, HCS, 1/4"-20 x 2-3/4"
191	129691	Shim, .75" ID, 1.125" OD, .06" L

Schematic - Main Axle Assembly

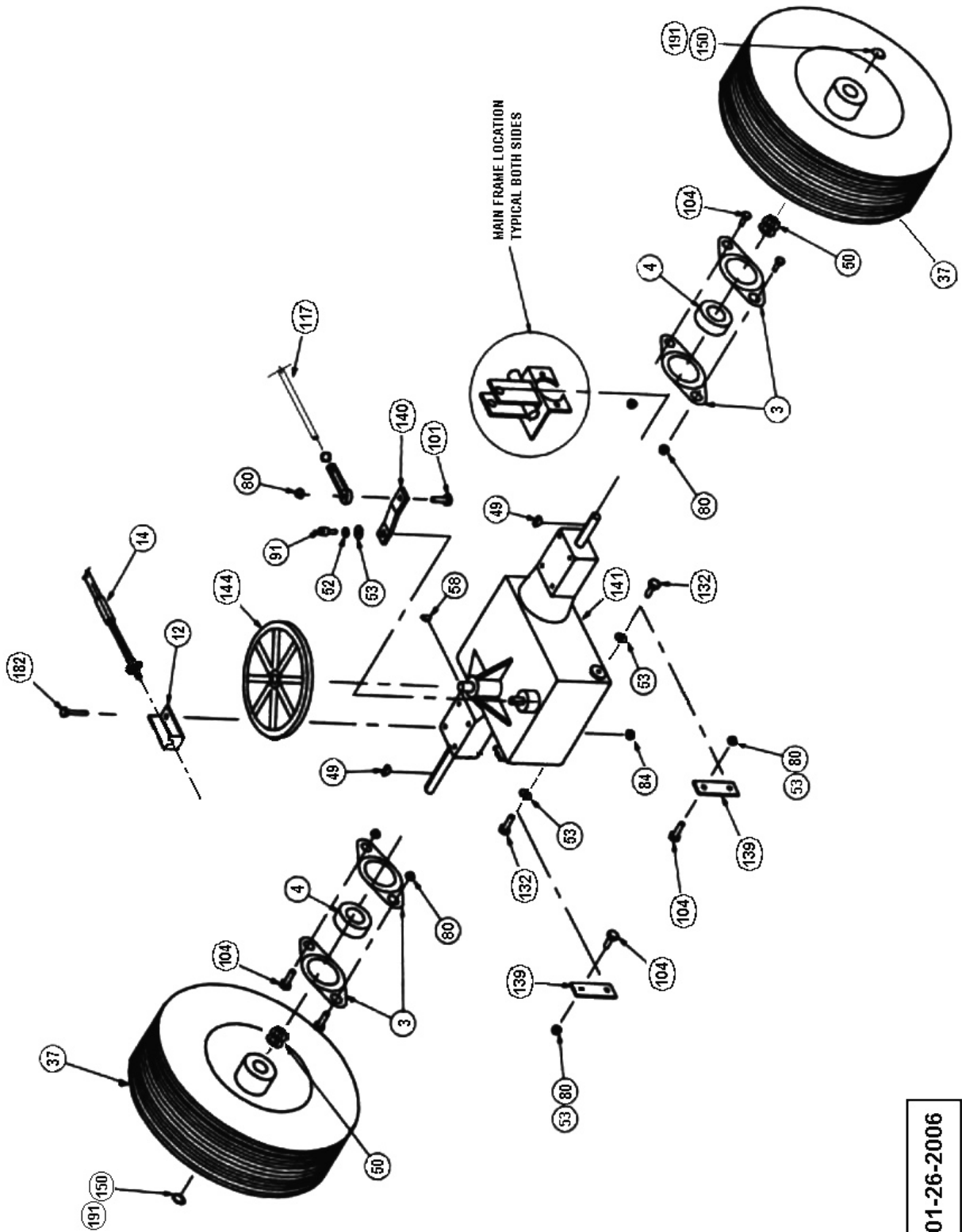

01-26-2006

Parts List - Molded Body Assembly

NOTE: Part numbers listed are available through Country Home Products, Inc.

<u>Ref#</u>	<u>Part#</u>	<u>Description</u>
19	109131	Bolt, 5/16"-18 x 1-1/2", Carriage
26	112311	Spacer, .327" ID, .500" OD, 1.5"
47	108771	Arm, Dump
48	109401	Bushing, .375" ID, .50" OD, 1.13" L
51	112411	Washer, Flat, 5/16" USS
59	110211	Grip, Handle, 1-1/4" Black
74	110691	Nut, 5/16"-18
79	110751	Nut, Nylon Lock, 3/8"-16
80	110761	Nut, Nylon Lock, 5/16"-18
82	111081	Plug, 1" x 1" OD
87	111531	Bolt, HCS, 3/8"-16 x 2-1/4"
99	111591	Bolt, HCS, 5/16"-18 x 2-1/2"
105	111411	Bolt, HCS, 5/16"-18 x 3"
128	112501	Washer, Lock, 5/16"
155	124561	Molded Bed, 34" x 44-1/2" x 9"
156	110071	Frame, Large, Molded Bed

Schematic - Molded Body Assembly

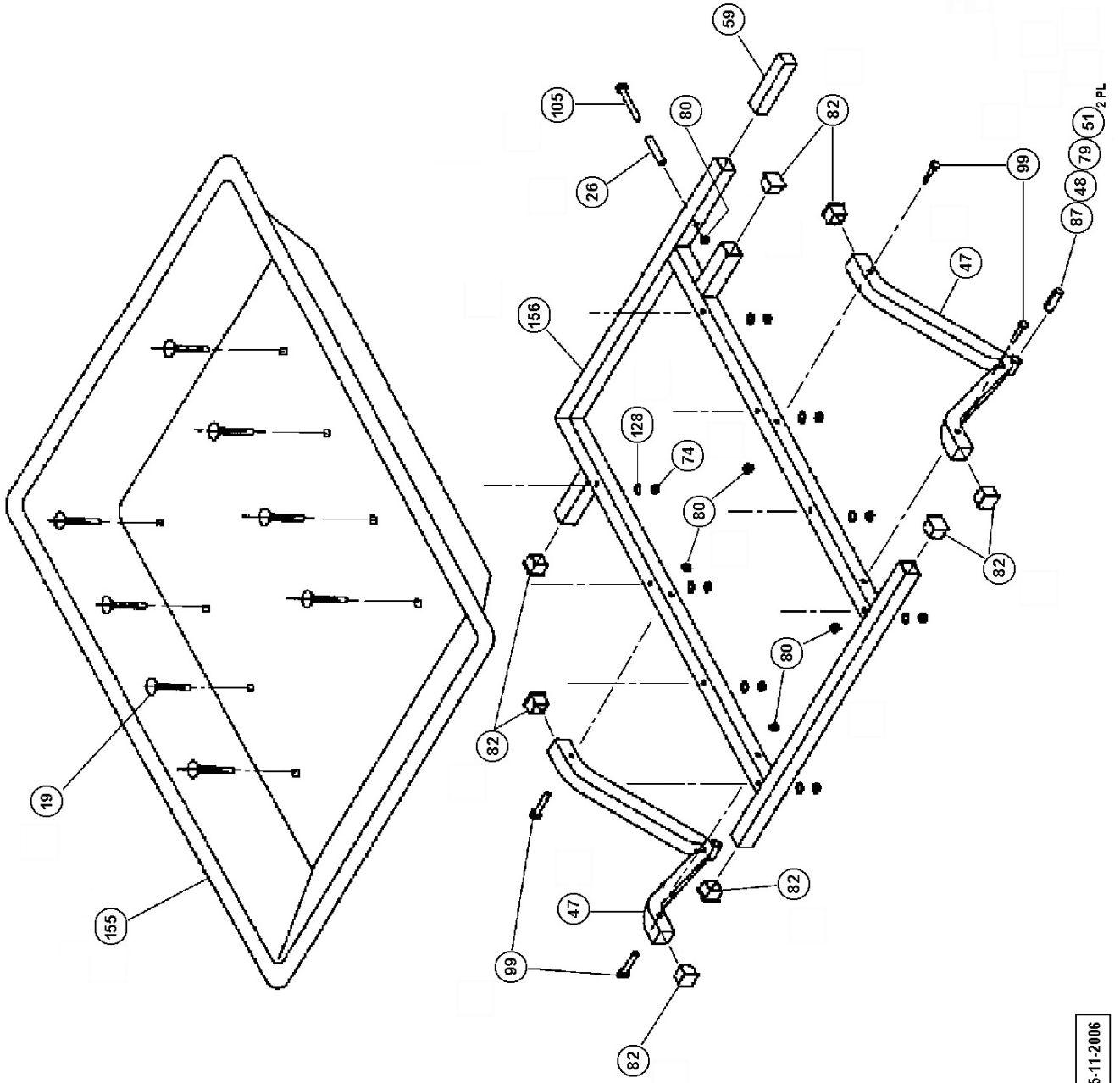

05-11-2006

Notes:

DR[®] POWERWAGON-PREMIER



2-Year Limited Warranty

Terms and Conditions

The DR[®] POWERWAGON-PREMIER is warranted for one (2) year against defects in materials or workmanship when put to ordinary and normal consumer use; ninety (90) days for any other use. The Engine manufacturer warrants the Engine separately.

For the purposes of all the above warranties, "ordinary and normal consumer use" refers to non-commercial residential use and does not include misuse, accidents, or damage due to inadequate maintenance.

Country Home Products, Inc. (home of DR[®] Power Equipment) certifies that the DR[®] POWERWAGON-PREMIER is fit for ordinary purposes for which a product of this type is used. Country Home Products, Inc. however, limits the implied warranties of merchantability and fitness in duration to a period of one (2) year in consumer use, ninety (90) days for any other use.

The 2-Year Limited Warranty on the DR[®] POWERWAGON-PREMIER starts on the date the machine ships from our factory. The 2-Year Limited Warranty is applicable only to the original owner.

The warranty holder is responsible for the performance of the required maintenance as defined by the Manufacturer's Owner's Manuals. The warranty holder is responsible for replacement of normally wearing parts such as the Drive Belt, Filters, Spark Plug, Brake Pads, and Battery. This warranty does not cover Attachments and Accessories to the machine.

During the warranty period, the warranty holder is responsible for the machine transportation charges, if required. During the warranty period, warranty parts will ship by standard method at no charge to the warranty holder. Expedited shipping of warranty parts is the responsibility of the warranty holder.

SOME STATES DO NOT ALLOW LIMITATIONS ON THE LENGTH OF IMPLIED WARRANTIES, SO THE ABOVE LIMITATIONS MAY NOT APPLY TO YOU.

Country Home Products, Inc. shall not be liable under any circumstances for any **incidental or consequential damages or expenses** of any kind, including, but not limited to, cost of equipment rentals, loss of profit, or cost of hiring services to perform tasks normally performed by the DR[®] POWERWAGON-PREMIER.

SOME STATES DO NOT ALLOW THE EXCLUSION OR LIMITATION OF INCIDENTAL OR CONSEQUENTIAL DAMAGES, SO THE ABOVE LIMITATIONS MAY NOT APPLY TO YOU.

Customer Service Hotline

Country Home Products, Inc.'s objective is to have 100% satisfied customers. For that reason, we operate a 6-day-a-week Technical Service Department for our Owners. You can access a Representative by dialing our TOLL-FREE Hotline at **1-800-DR-OWNER (376-9637)**. The sole job of our well-trained and friendly folks is to ensure that you get any help you need in a timely fashion. They are there to answer all your questions including: (1) inquiries on any of the above warranties, (2) inquiries about replacement parts, or (3) your questions regarding service, maintenance, and operation.

Our Customer Service Representatives will also be happy to answer any of your questions regarding the separate warranties on all Engines. However, to obtain service, repair or replacement of any Engine within the time period covered by the manufacturer's limited warranty, follow the instructions and warranty information specifically pertaining to those items provided by their separate manufacturers.

THIS WARRANTY GIVES YOU SPECIFIC LEGAL RIGHTS, AND YOU HAVE OTHER RIGHTS, WHICH VARY FROM STATE TO STATE.

Daily Checklist for the POWERWAGON-PREMIER

To help maintain your DR for optimum performance, we recommend you follow this checklist each time you use your machine.

- [] OIL: With the machine on a level surface, remove the oil fill cap and check the oil level. Fill the reservoir according to the dipstick with SAE30 HD motor oil.
- [] GAS: Fill the gas tank with fresh, unleaded gasoline.
- [] ENGINE: It is very important to keep the Engine clean. Remove grass and other debris from the Engine cooling fins and Debris Guard. A dirty Engine retains heat and can cause damage to internal Engine components.
- [] BELT: Check the Drive Belt for wear, proper alignment and tension.
- [] AIR FILTER: A clean Air Filter will mean a much easier starting and cooler running Engine. Please refer to your Engine Owner's Manual for instructions on cleaning the Air Filter.
- [] TIRES: Check the Tires for wear and proper inflation.



DR® Power Equipment, A division of Country Home Products®

127 MEIGS ROAD, P.O. BOX 25, VERGENNES, VERMONT 05491

1-800-DR-OWNER (376-9637) • www.dr-owner.com

©2007 CHP, Inc. 223611