

Unpacking Instructions GENERAC® TRIMMER/MOWER

! WARNING

- Stabilize the shipping box at floor level in a clean flat area before attempting to unpack the trimmer/mower.
- For your safety we recommend you have two people to lift the Trimmer/Mower from the box to prevent injury.

Tools Needed:

- Utility Knife
- Wire Cutters

Unpack for Non Self Propelled (Self Propelled on opposite page)

1. Position the Shipping Box at floor level in a clean flat area with the text on the side of the Box right side up (**Figure 1**).
2. With a Utility Knife, cut the Tape that secures the Box Flaps at both ends and along the center.

Parts Supplied in Box:

- GENERAC TRIMMER/MOWER
- Product Package (plastic bag with owner's manual, engine manual and other product information)
- Trimmer Cord Pack

Compare the contents of the Shipping Box with the “Parts Supplied” list above. If you have any questions please contact us at 1-888-545-6576 for assistance.

3. Lift the Wheel Stabilizer Cardboard Insert from the rear of the Trimmer (**Figure 2**).

Note: You will need two people to lift the Trimmer from the Box. At the back end of the machine, lift on the Lower Handlebar and at the front, lift on the Nose and Upper Handlebar.

4. With help from another person, lift the Trimmer from the Shipping Box (**Figure 3**).
5. Cut the Cable Zip Ties holding the Bail Bar to the Handlebar.
6. The four Bolts attaching the lower Handlebar to the Frame can sometimes become loose in shipping. Ensure that the Bolts are tight using a 1/2" Wrench.
7. Remove the Product Package with Trimmer Cords from the Shipping Box.
8. Do not remove the other cardboard from the box. Place the Wheel Stabilizer Insert into the Box and keep the packing materials for future use.

Refer to Chapter 2 “Setting up your TRIMMER/MOWER” of your Generac® TRIMMER/MOWER Safety & Operating Instructions manual to continue with the setup of your machine. The manual also includes important first time start-up procedures. It is located in the Product Package that came with your machine. Do not discard your Trimmer packaging materials. Store the shipping box and all inserts in a dry, safe area for future use. If there are any questions contact us at 1-888-545-6576. If for any reason you need to ship the machine back to us, drain the gas and oil, use the original packaging and follow the reverse order of the previous unpacking instructions.

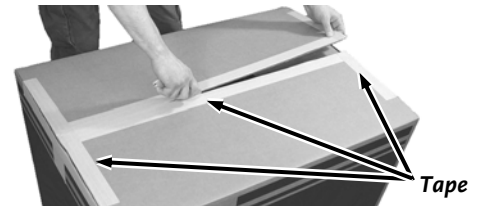

Figure 1



Figure 2

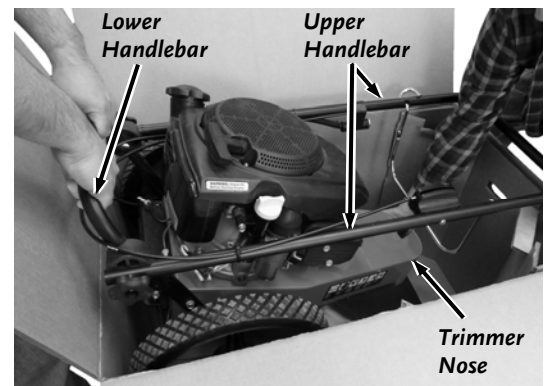

Figure 3

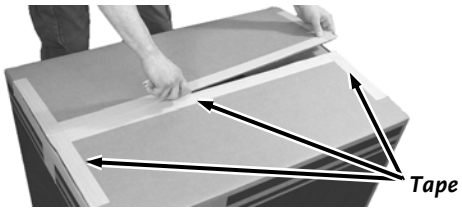

Figure 4

Unpack for Self Propelled (Non Self Propelled on opposite page)

1. Position the Shipping Box at floor level in a clean flat area with the text on the side of the Box right side up (**Figure 4**).
2. With a Utility Knife, cut the Tape that secures the Box Flaps at both ends and along the center.

Parts Supplied in Box:

- GENERAC TRIMMER/MOWER
- Product Package (plastic bag with owner's manual, engine manual and other product information)
- Trimmer Cord Pack

Compare the contents of the Shipping Box with the "Parts Supplied" list above. If you have any questions please contact us at 1-888-545-6576 for assistance.

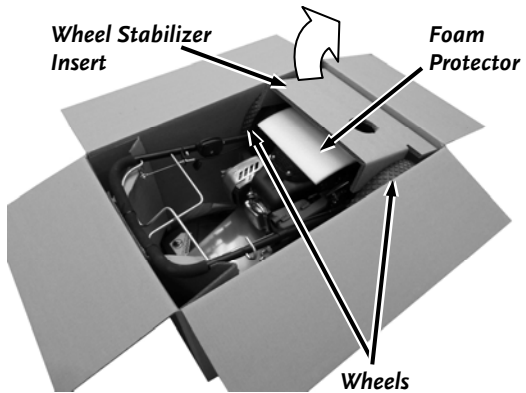

Figure 5

3. Lift up the Wheel Stabilizer Cardboard Insert and remove the Foam Protector (**Figure 5**).
4. Remove the Wheels and the Wheel Stabilizer Insert from the Box.

Note: You will need two people to lift the Trimmer from the Box. At the back end of the machine, lift on the Lower Handlebar and at the front, lift on the Nose and Upper Handlebar.

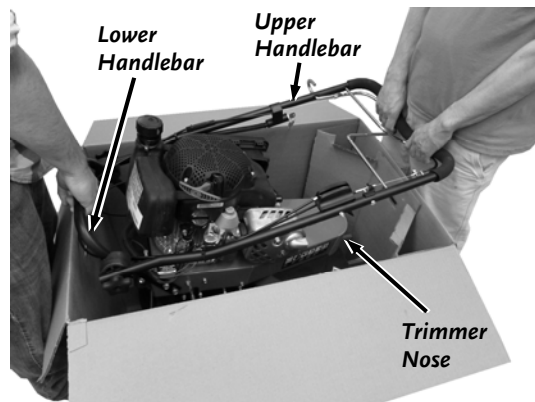

Figure 6

5. With help from another person, lift the Trimmer from the Shipping Box (**Figure 6**).
6. Cut the Cable Zip Ties holding the two Bail Bars to the Handlebar.
7. The four Bolts attaching the lower Handlebar to the Frame can sometimes become loose in shipping. Ensure that the Bolts are tight using a 1/2" Wrench.
8. Remove the Product Package with Trimmer Cords from the Shipping Box.
9. Do not remove the other cardboard from the box. Place the Wheel Stabilizer Insert into the Box and keep the packing materials for future use.

Refer to Chapter 2 "Setting up your TRIMMER/MOWER" of your Generac® TRIMMER/MOWER Safety & Operating Instructions manual to continue with the installation of the Wheels and the setup of your machine. The manual also includes important first time start-up procedures. It is located in the Product Package that came with your machine. Do not discard your Trimmer packaging materials. Store the shipping box and all inserts in a dry, safe area for future use. If there are any questions contact us at 1-888-545-6576. If for any reason you need to ship the machine back to us, drain the gas and oil, use the original packaging and follow the reverse order of the previous unpacking instructions.

