

# DR<sup>®</sup> PRO-XL CHIPPER-SHREDDER SAFETY & OPERATING INSTRUCTIONS



Model:  
PRO-XL

Serial No. \_\_\_\_\_

Order No. \_\_\_\_\_

DR Power Equipment  
Toll-free phone: 1-800-DR-OWNER (376-9637)  
Website: [www.DRpower.com](http://www.DRpower.com)

## **WARNING**

Read and understand this manual and all instructions before operating the DR PRO-XL CHIPPER-SHREDDER.

# Table of Contents

Chapter 1: General Safety Rules..... 3  
Chapter 2: Setting Up the DR PRO-XL CHIPPER-SHREDDER ..... 9  
Chapter 3: Operating the DR PRO-XL CHIPPER-SHREDDER ..... 13  
Chapter 4: Maintaining the DR PRO-XL CHIPPER-SHREDDER..... 18  
Chapter 5: Troubleshooting ..... 32  
Chapter 6: Parts Lists and Schematic Diagrams..... 34

## Conventions used in this manual

### DANGER

This indicates a hazardous situation, which, if not followed, **will** result in death or serious injury.

### WARNING

This indicates a hazardous situation, which, if not avoided, **could** result in death or serious injury.

### CAUTION

This indicates a hazardous situation, which, if not avoided, **could** result in minor or moderate injury.

### NOTICE

This information is important in the proper use of your machine. Failure to follow this instruction could result in damage to your machine or property.

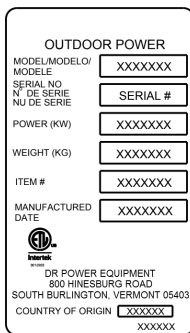


Figure 1

## Serial Number and Order Number

A Serial Number is used to identify your machine and is located on the Serial Number Label on your machine (**Figure 1**). An Order Number is used to check and maintain your order history and is located on your packing slip. For your convenience and ready reference, enter the Serial Number and Order Number in the space provided on the front cover of this manual.

## Additional Information and Potential Changes

DR Power Equipment reserves the right to discontinue, change, and improve its products at any time without notice or obligation to the purchaser. The descriptions and specifications contained in this manual were in effect at printing. Equipment described within this manual may be optional. Some illustrations may not be applicable to your machine.

## California Proposition 65

 **WARNING**  
**CANCER AND REPRODUCTIVE HARM - [www.P65Warnings.ca.gov](http://www.P65Warnings.ca.gov).**

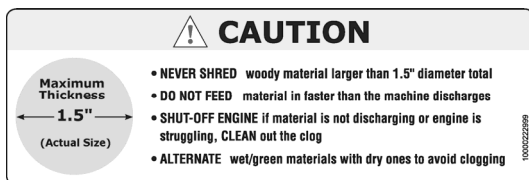
## Chapter 1: General Safety Rules

### **WARNING**

Read this Safety & Operating Instructions Manual before you use the DR PRO-XL CHIPPER-SHREDDER. Become familiar with the operation and service recommendations to ensure the best performance from your machine. If you have any questions or need assistance, please contact us at [www.DRpower.com](http://www.DRpower.com) or call Toll-Free 1-800-DR-OWNER (376-9637) and one of our Technical Support Representatives will be happy to help you.

### Labels

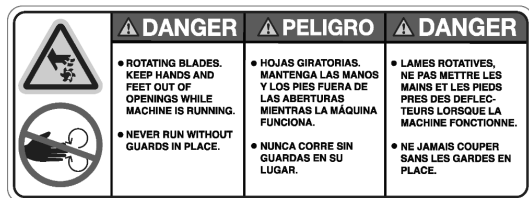
Your DR PRO-XL CHIPPER-SHREDDER carries prominent labels as reminders for its proper and safe use. Shown below are copies of all the Safety and Information labels that appear on the equipment. Take a moment to study them and make a note of their location on your DR PRO-XL CHIPPER-SHREDDER as you set up and before you operate the unit. Replace damaged or missing Safety and Information labels immediately.



#1000022999



#10000042639



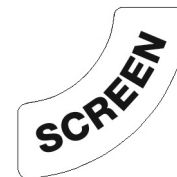
#10000042667



#250441



#10000043333



#386691



#10000042683



#188871



#137581

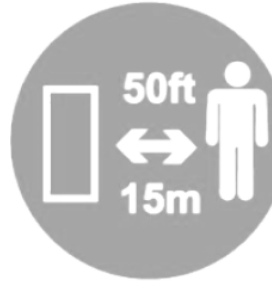
## Pictogram Descriptions



This label indicates proximity to machine openings with rotating blades inside.

**SERIOUS INJURY OR DEATH** will occur if hands, feet, or any part of your body are placed in the chipper hopper, discharge opening, or near or under any moving part while the machine is running.

Never run without guards in place.



Keep bystanders 50 feet away from your work area at all times. Wood chips exit the chipper at great speeds. To be safe, do not operate the machine near small children or pets, and never allow children to operate the chipper. Stop the engine when another person or pet approaches.



Never reach into feed hoppers, discharge opening, or maintenance openings. **SERIOUS INJURY OR DEATH** may occur.



Use ear protectors or ear plugs rated for at least 20 dba to protect your hearing.



Machine may discharge wood chips and debris at great speeds. Keep area of discharge clear of people, animals, buildings, glass, or anything else that will obstruct clear discharge, cause injury, or damage. Wind can also change discharge direction, so be aware.



Always wear protective goggles or safety glasses with side shields while chipping to protect your eyes from possible thrown debris.



Do Not Exceed 10 mph while towing a chipper equipped with a Yard Tow Kit. Never tow the Yard-Tow model over roads.



Read this safety & operating Instructions manual before you use the machine. Become familiar with the operation and service recommendations to ensure the best performance.

## Protecting Yourself and Those around You

---

### **WARNING**

This is a high-powered machine, with moving parts operating with high energy at high speeds. You must operate the machine safely. Unsafe operation can create a number of hazards for you, as well as anyone else in the nearby area. Always take the following precautions when using this machine:

- Always wear protective goggles or safety glasses with side shields while chipping/shredding to protect your eyes from possible thrown debris.
  - Avoid wearing loose clothing or jewelry, which can catch on moving parts or the material fed into the hoppers.
  - We recommend wearing gloves while chipping or shredding. Be sure your gloves fit properly and do not have loose cuffs or drawstrings.
  - Wear shoes with non-slip treads when using your DR PRO-XL CHIPPER-SHREDDER. If you have safety shoes, we recommend wearing them. Do not use the machine while barefoot or wearing open sandals.
  - Wear long pants while operating the DR PRO-XL CHIPPER-SHREDDER.
  - Use ear protectors or ear plugs rated for at least 20 dba to protect your hearing.
  - Never allow people who are unfamiliar with these instructions to use the DR PRO-XL CHIPPER-SHREDDER. Allow only responsible individuals who are familiar with these rules of safe operation to use your machine.
  - Never place your hands, feet, or any part of your body in the Hoppers, discharge opening, or near or under any moving part while the machine is running. Keep area of discharge clear of people, animals, buildings, glass, or anything else that will obstruct clear discharge, cause injury, or damage. Wind can also change discharge direction, so be aware. If it becomes necessary to push material into the hoppers, use a small diameter stick, not your hands.
  - Keep bystanders 50 feet away from your work area at all times. Wood chips and shredder debris exit the machine at great speeds. To be safe, do not operate the machine near small children or pets, and never allow children to operate the DR PRO-XL CHIPPER-SHREDDER. Stop the engine when another person or pet approaches.
  - Never use the machine without ensuring that all guards and shields are in place, including the chipper hopper, discharge chute and blowback shield.
  - Always operate the machine from the operator zone (see chapter 3). Never pass or stand on the discharge side of the machine when the engine is running, or the Rotor is turning.
  - Never try to pick up, move, or transport the machine while the engine is running, or the rotor is turning.
  - Clear the area of objects such as wire, rope, etc. Inserting these objects into the chipper or shredder hopper could damage the machine and/or cause injury.
  - Never, under any conditions, remove, bend, cut, fit, weld, or otherwise alter standard parts on the DR PRO-XL CHIPPER-SHREDDER. This includes all Shields and Guards. Modifications to your machine could cause personal injuries and property damage and void your warranty.
- 

## Safety for Children and Pets

---

### **WARNING**

Tragic accidents can occur if the operator is not alert to the presence of children and pets. Children are often attracted to the machine and the chipping/shredding activity. Never assume that children will remain where you last saw them. Always follow these precautions:

- Keep children and pets at least 50 feet from the working area and under the watchful care of a responsible adult.
  - Be alert and turn the machine off if children or pets enter the work area.
  - Never allow children to operate the DR PRO-XL CHIPPER-SHREDDER.
-

## ***Safety with Gasoline - Powered Machines***

---

### **! WARNING**

Gasoline is a highly flammable liquid. Gasoline also gives off flammable vapor that can be easily ignited and cause a fire or explosion. Never overlook the hazards of gasoline. Always follow these precautions:

- Never run the Engine in an enclosed area or without proper ventilation as the exhaust from the Engine contains carbon monoxide, which is an odorless, tasteless, and deadly poisonous gas.
  - Store all fuel and oil in containers specifically designed and approved for this purpose and keep away from heat and open flame, and out of the reach of children.
  - Replace rubber Fuel Lines and Grommets when worn or damaged and after 5 years of use.
  - Fill the Gasoline Tank outdoors with the Engine off and allow the Engine to cool completely. Don't handle gasoline if you or anyone nearby is smoking, or if you're near anything that could cause it to ignite or explode. Reinstall the Fuel Tank Cap and Fuel Container Cap securely.
  - If you spill gasoline, do not attempt to start the Engine. Move the machine away from the area of the spill and avoid creating any source of ignition until the gas vapors have dissipated. Wipe up any spilled fuel to prevent a fire hazard and properly dispose of the waste.
  - Allow the Engine to cool completely before storing in any enclosure. Never store a machine that has gas in the tank, or a Fuel Container, near an open flame or spark such as a water heater, space heater, clothes dryer or furnace.
  - Never make adjustments or repairs with the Engine running. Shut down the Engine, disconnect the Spark Plug wire, keeping it away from the Spark Plug to prevent accidental starting and wait 5 minutes before making adjustments or repairs.
  - Never tamper with the Engine's Governor setting. The Governor controls the maximum safe operation speed and protects the Engine. Over-speeding the Engine is dangerous and will cause damage to the Engine and to the other moving parts of the machine. If required, see your authorized dealer for Engine governor adjustments.
  - Keep combustible substances away from the Engine when it is hot.
  - Never cover the machine while the Muffler is still hot.
  - Do not operate the Engine with the Air Cleaner or the Carburetor Air Intake Cover removed. Removal of such parts could create a fire hazard. Do not use flammable solutions to clean the Air Filter.
  - The Muffler and Engine become very hot and can cause a severe burn; do not touch.
-

## General Safety

### DANGER

Operating this DR PRO-XL CHIPPER-SHREDDER safely is necessary to prevent or minimize the risk of death or serious injury. Unsafe operation can create a number of hazards for you. Always take the following precautions when operating this machine:

- Your DR PRO-XL CHIPPER-SHREDDER is a powerful tool, not a plaything. Exercise extreme caution at all times. The machine is designed to chip wood and shred most organic materials. Do not use it for any other purpose.
- Thoroughly inspect the area in which you will be working and remove all foreign objects. Look for rope, wire, etc., and remove these objects before chipping/shredding. Inserting these objects into the DR PRO-XL CHIPPER-SHREDDER Hopper could damage the machine and/or cause injury.
- Know how to stop the DR PRO-XL CHIPPER-SHREDDER quickly by turning the key to the “OFF” position (refer to chapter 3).
- Never operate your unit on a slippery, wet, muddy, or icy surface. Exercise caution to avoid slipping or falling.
- See manufacturer’s instructions for proper operation and installation of accessories. Only use accessories approved by DR Power Equipment.
- Never use the machine without ensuring that all guards and shields are in place.
- Never use the machine with the Hopper(s) removed.
- Keep your face and body back from the DR PRO-XL CHIPPER-SHREDDER Hopper(s) to avoid accidental bounce back of any material.
- Do not allow an accumulation of processed material to build up in the discharge area as this will prevent proper discharge and can result in kickback from the DR PRO-XL CHIPPER-SHREDDER Hopper(s).
- Allow only one person to operate the DR PRO-XL CHIPPER-SHREDDER at any time.
- Always operate the machine from the Operator Zone (see **Figure 11** on page 15). Never pass or stand on the discharge side of the machine when the Engine is running, or the Rotor is turning.
- If the machine should start making an unusual noise or vibration, shut down the Engine, disconnect the Spark Plug Wire, keeping it away from the Spark Plug to prevent accidental starting, wait 5 minutes, then inspect for damage. Vibration is generally a warning of trouble. Check for damaged parts and clean, repair, and/or replace as necessary.
- Never tamper with safety devices. Check their proper operation regularly.
- Never try to pick up, move, or transport the machine while the Engine is running, or the Rotor is turning.
- Before performing any maintenance or inspection procedure on the DR PRO-XL CHIPPER-SHREDDER, shut the Engine OFF, remove the Spark Plug Wire, and keep it away from the Spark Plug.
- Never allow people who do not understand and/or have not read this Safety and Operating Instructions Manual to use the DR PRO-XL CHIPPER-SHREDDER. Allow only responsible individuals who are familiar with these rules of safe operation to use your machine.
- Never overload or attempt to Chip or Shred material beyond the manufacturer’s recommendation. Personal injury or damage to the machine could result.
- While using the DR PRO-XL CHIPPER-SHREDDER, don't hurry or take things for granted. When in doubt about the equipment or your surroundings, stop the machine and take the time to look things over.
- Never operate the machine when under the influence of alcohol, drugs, or medication.
- Use the machine only in daylight.
- Stay alert for hidden hazards or traffic.
- Keep all nuts and bolts tight and keep the equipment in good operating condition.

### ***A Note to All Users***

Under California law, and the laws of some other states, you are not permitted to operate an internal combustion engine using hydrocarbon fuels without an Engine Spark Arrestor. This also applies to operation on US Forest Lands. All DR PRO-XL CHIPPER-SHREDDER'S shipped to California, New Mexico, and Washington State are provided with Spark Arrestors. Failure of the owner or operator to maintain this equipment in compliance with state regulations is a misdemeanor under California law and may be in violation of other state and/or federal regulations. Contact your State Park Association or the appropriate state organization for specific information in your area.

No list of warnings and cautions can be all-inclusive. If situations occur that are not covered by this manual, the operator must apply common sense and operate this DR PRO-XL CHIPPER-SHREDDER in a safe manner. Contact us at [www.DRpower.com](http://www.DRpower.com) or call Toll Free: 1-800-DR-OWNER (376-9637) for assistance.



## Chapter 2: Setting Up the DR PRO-XL CHIPPER-SHREDDER

It may be helpful to familiarize yourself with the controls and features of your DR PRO-XL CHIPPER-SHREDDER as shown in **Figure 2** before beginning these procedures. If you have any questions at all, please feel free to contact us at [www.DRpower.com](http://www.DRpower.com).

### PRO-XL CHIPPER-SHREDDER Controls and Features

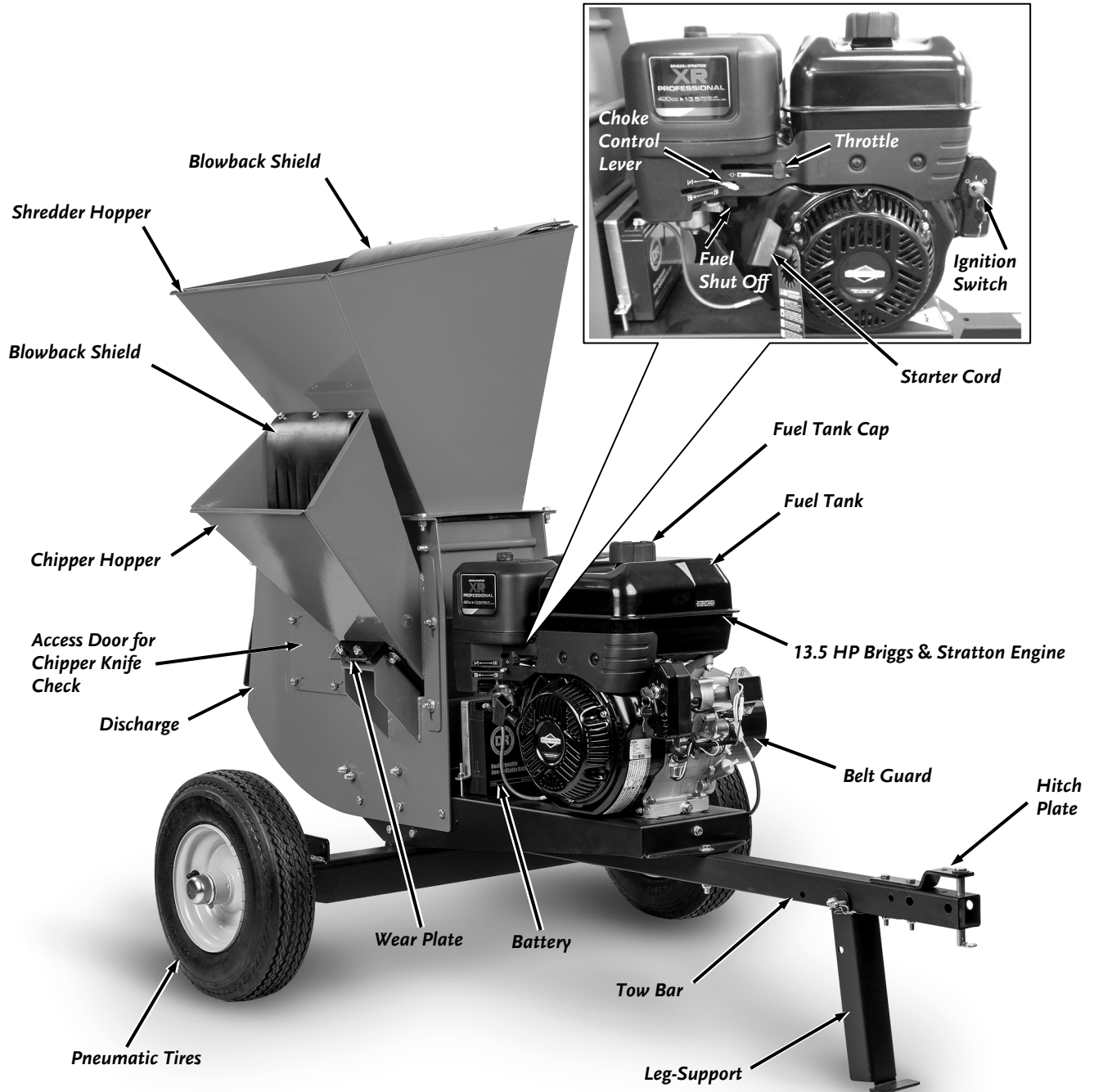


Figure 2

## Specifications

<b>Model</b>	PRO-XL
<b>Engine</b>	13.5 HP Briggs & Stratton (See Engine Manual for Engine Specifications)
<b>Oil Type</b>	SAE-30
<b>Engine Starting</b>	Electric w/Recoil Backup
<b>Chipping Capacity</b>	5" Diameter
<b>Max. Towing Speed</b>	10 MPH
<b>Number of Chipper Knives</b>	1
<b>Chipper Knife Size</b>	6-1/4" x 1-1/4" x 3/8"
<b>Chipper Knife Material</b>	Heat Treated Tool Steel
<b>Adjustable Knife Wear Plate</b>	Yes
<b>Chipper Rotor</b>	16-1/2" Diameter, 3/4" Thick
<b>Chipper Knife Speed</b>	97 MPH
<b>Chipper Hopper Opening</b>	8" x 14"
<b>Shredder Hopper Opening</b>	19" x 17"
<b>Shredding Capacity</b>	1-1/2"
<b>Number of Hammers</b>	24
<b>Shredder Chamber Hits/Min.</b>	48,336
<b>Hammer Features</b>	Free Swinging, Serrated, Reversible 3 Times
<b>Hammer Size/Type</b>	3-1/2" x 1-1/2" x 7 Ga. Heat Treated
<b>Standard Screen w/Unit</b>	84 Hole
<b>Wheel Size</b>	16.5" x 4.80/4.00-8 Pneumatic-
<b>Machine Weight</b>	407 Lbs.
<b>Overall Length</b>	79"
<b>Overall Width</b>	47"
<b>Overall Height</b>	53"

## Assembling the DR PRO-XL CHIPPER-SHREDDER

### Contents Supplied in Shipping Crate (Figure 3 and list below):

Item #	Description	Qty
1	Shredder Hopper Assembly	1
2	Product Package	1
Not Shown	DR Pro-XL Chipper-Shredder	1

### Hardware supplied in Product Package (Figure 4 and list below):

Item #	Part #	Description	Qty
1	197091	Gauge, Knife Gap, CPRA	1
2	110751	Nut, Nylon Lock, 3/8-16	4
3	121701	Washer, Flat, 3/8", SAE	4
4	111521	Bolt, HCS, 3/8-16 X 1", GR5, ZP	4
5	380691	Spark Arrester, B&S 816479 (Not Shown)	1

Compare the contents of the Shipping Crate and the Product Package with the Contents and Hardware Supplied lists above. **If you have any questions, contact us at [www.DRpower.com](http://www.DRpower.com) or call 1-800-DR-OWNER (376-9637).** Do not discard your packaging material until you are fully satisfied with your new DR PRO-XL CHIPPER-SHREDDER.

### Attaching the Shredder Hopper

#### Tools Needed:

- Two 9/16" Wrenches

1. Check to verify that the "U" Channel Trim is seated on the Upper Scroll Housing (Figure 5).
2. Place the Shredder Hopper onto the Shredding Chamber in the configuration shown (Figure 6).
3. Secure the Shredder Hopper to the Shredding Chamber with four 3/8"-16 x 1" Bolts, 3/8" Washers, and 3/8" Locknuts from the Product Package using two 9/16" Wrenches.

**Note:** The Bolts and Washers should be installed on the top side of the Shredder Hopper flange and the Locknuts on the bottom.

### Connecting the Battery Wire

We ship all DR PRO-XL CHIPPER-SHREDDER'S with the Negative Terminal Battery Wire disconnected. This prevents the Battery from discharging during shipment. Before using your DR PRO-XL CHIPPER-SHREDDER, you must connect the Battery Wire.

#### Tools Needed:

- Two 5/16" Wrenches

1. Remove the Bolt and Nut from the Negative Terminal of the Battery using two 5/16" Wrenches (Figure 7).
2. Attach the Negative Wire to the Negative Terminal with the Bolt and Nut using two 5/16" Wrenches.



Figure 3



Figure 4

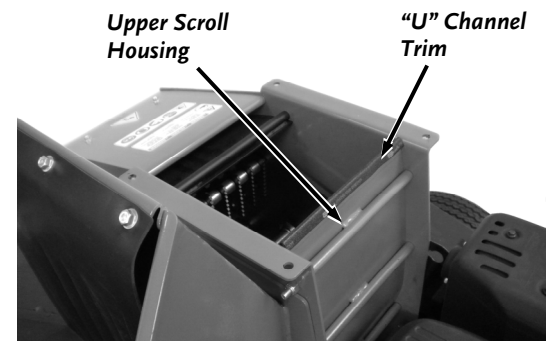


Figure 5

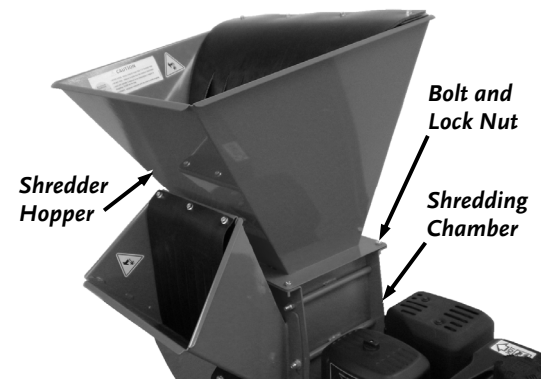


Figure 6

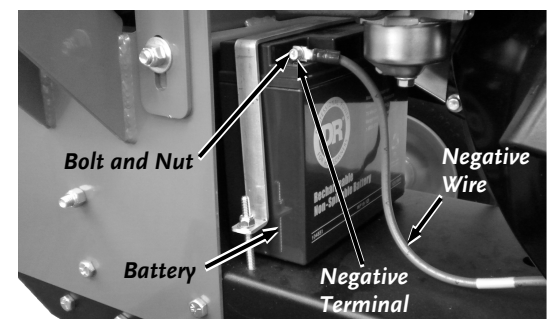


Figure 7

## Checking/Setting the Knife to Wear Plate Gap

### NOTICE

The Wear Plate is installed at the factory at an approximate location for shipping purposes. You must check/adjust the Knife to Wear Plate gap before using the Chipper Shredder. Ensuring the gap is correct will ensure optimum chipping performance.

Check and (if necessary) adjust the Wear Plate as described in the “Check and Adjusting the Knife to Wear Plate Gap” section on page 23.

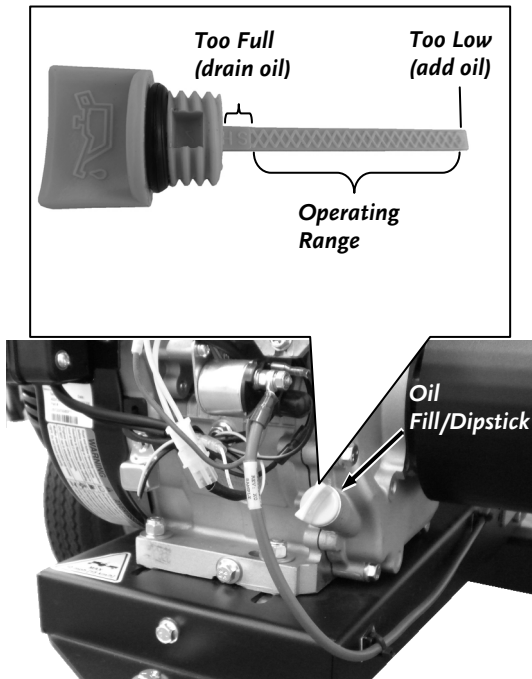


Figure 8

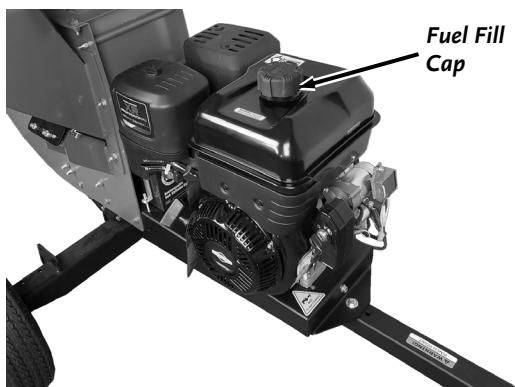


Figure 9

## Adding Engine Oil

### NOTICE

- You must add Oil before starting the Engine. This machine is shipped without Oil. Traces of Oil may be in the reservoir from factory testing, but you must add Oil before starting the Engine. Fill the reservoir slowly, checking the level frequently to avoid overfilling.
- To get an accurate reading when checking the Oil level:
  - The Engine must be level.
  - The Dipstick must be screwed all the way in to ensure an accurate Oil level reading.

<b>Engine Oil</b>	SAE 30 Oil - 37 oz. (1.09 L): above 50 degrees F; 10w-30: 30-90 degrees F; 5w-30: 30 degrees F or below
<b>Fuel</b>	Unleaded gasoline, 7 US quarts (6.53 L)

**Note:** Use only the recommended high detergent Engine Oil. Do not use special additives. Other types of Oil could cause problems operating your machine. Please refer to your Engine Owner's Manual for more detailed oil information.

- Place the machine on a level surface.
- Remove the Engine Oil Fill/Dipstick and initially add 1/2 of the SAE 30 high detergent Oil recommended by the Engine Manufacturer and wait one minute for the Oil to settle (**Figure 8**).
- Screw the Dipstick in and then remove it to check the Oil level (clean the Dipstick with a rag after checking) and continue adding a few ounces of Oil at a time, rechecking the Dipstick until the Oil reaches the FULL mark. Be careful not to overfill.
- Replace the Dipstick and screw all the way in when full.

## Adding Gasoline

### ! WARNING

Add Fuel outdoors or in a well-ventilated area, away from sparks, open flames, pilot lights, heat, and other ignition sources.

- Remove the Fuel Fill Cap and fill the Fuel Tank with fresh, unleaded gas (with a minimum of 85 Octane) to approximately 1" to 1-1/2" below the top of the Fill Neck to allow for Fuel expansion (**Figure 9**). Be careful not to overfill.
- Reinstall the Fuel Tank Cap before starting the Engine. See your Engine Owner's Manual for more detailed information.

**Note:** When Refueling the Fuel Tank, turn the Engine OFF, and let the Engine cool at least five minutes before removing the Fuel Tank Cap.

## Chapter 3: Operating the PRO-XL CHIPPER-SHREDDER

This chapter covers the procedures for starting and stopping your new DR PRO-XL CHIPPER-SHREDDER and discusses basic operation features. It may be helpful to better familiarize yourself with the features of your DR PRO-XL CHIPPER-SHREDDER by reviewing **Figure 2** in Chapter 2 before beginning the steps outlined in this chapter.

### **⚠ WARNING**

Read and understand the warnings listed in “Chapter 1 General Safety Rules” before operating this DR PRO-XL CHIPPER-SHREDDER.

### **Starting the Engine**

1. Check the Oil and Fuel level every time you use the DR PRO-XL CHIPPER-SHREDDER.
2. Turn the Fuel Shut-Off Valve to the right to the ON position (**Figure 10**).
3. Position Choke Control Lever to the left so it is in the Choke position (Leave it in the RUN position to the right if the Engine is already warm).
4. Move the Throttle Control Lever to about half way between Slow (turtle) and Fast (rabbit) Position.
5. Turn the Key fully to the right to the START position until the Engine starts, then release. The Key will snap back to the middle RUN position and the Engine will continue to run.
6. As the Engine warms up, slowly move the Choke to the right until the Engine runs smoothly.
7. When the Engine is warmed up and running smoothly, ensure that the Choke is fully to the right and the Throttle Control Lever is fully to the left (rabbit) Position for Chipping and Shredding.

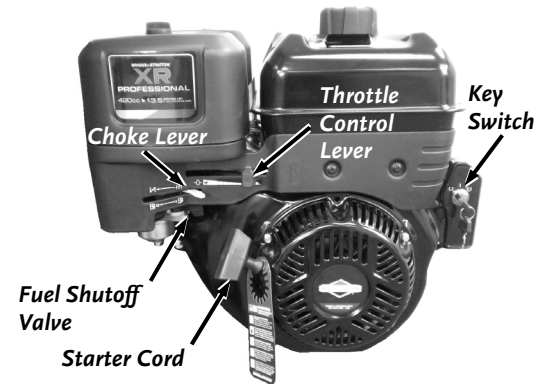


Figure 10

### **Stopping the Engine**

1. Move the Throttle Control Lever all the way to the SLOW (turtle) position and then turn the Key to left OFF.
2. Remove the Key for safety.

**NOTE:** Close the Fuel Shut-Off when transporting or storing the DR PRO-XL CHIPPER-SHREDDER.

### **Before You Begin**

- Visually check the Chipper Knife for damage each time you use the machine.

**NOTE:** Check for shaft movement while increasing Engine speed. If the shaft does not turn, clean out the Chipper/Shredder Hopper(s).

- When viewed from the Chipper Hopper side of the Operator's Zone (**Figure 11**), the Rotor turns in a clockwise direction.
- ALWAYS operate the PRO-XL CHIPPER-SHREDDER from the Operator Zone.
- ALWAYS stop the Engine when leaving the Operating Zone or when moving the machine.

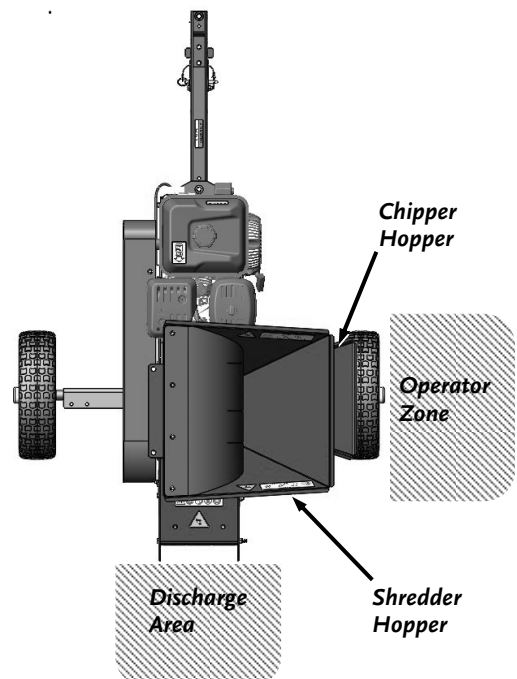


Figure 11

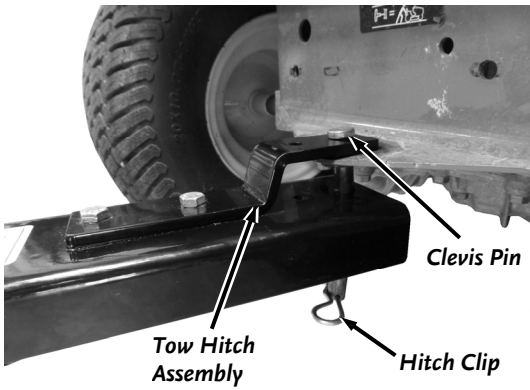


Figure 12

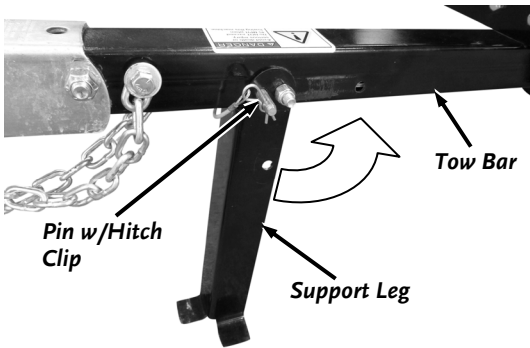


Figure 13

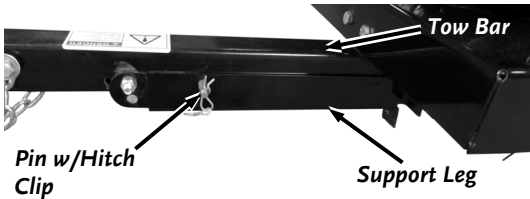


Figure 14

## Connecting the PRO-XL CHIPPER-SHREDDER to your Tow Vehicle Hitch

### NOTICE

Always secure the Support Leg in the up (transport) position before towing to prevent damage to the machine.

1. Lift the Chipper Tow Bar onto the Tow Vehicle Hitch and install the Clevis Pin and Hitch Clip to secure it (**Figure 12**).
2. Pull the Hitch Clip from the Clevis Pin and pull the Pin from the Support Leg and Tow Bar (**Figure 13**).
3. Rotate the Support Leg to the up (transport) position, align the holes in the Tow Bar and Leg, reinstall the Clevis Pin and secure with the Hitch Clip (**Figure 14**).

### ! DANGER

Avoid death or serious injury. Do not exceed 10 mph when towing the Yard-Tow model. Never tow the Yard-Tow model over roads.

## Processing Material

### WARNING

Read and understand the warnings listed in “Chapter 1 General Safety Rules” before operating this DR PRO-XL CHIPPER-SHREDDER.

- Your DR PRO-XL CHIPPER-SHREDDER can process dry or green material.
- Green wood will process quicker and easier than dry wood.
- Softwood processes easier than hardwood.
- Your operator experience will teach you how different materials chip/shred and how fast you can process different materials.
- It is best to trim off any side twigs from the main branch that you are chipping.
- When chipping branches, sometimes a tail will remain at the end of a branch. To avoid this, rotate the branch while feeding it into the Chipper Hopper. Rotating the branch as you feed it into the machine will improve chipping performance.
- Use caution with small diameter green saplings and branches less than 2" in diameter. Chip these grouped or bundled together to provide support for each other. If the material is 2" or larger, feed only one at a time into the Chipper Hopper.
- Make sure the Shredding Chamber finishes processing material in the Hopper(s) before shutting the Engine off.

### *Using the Chipper Hopper*

The Chipper Hopper is mounted on the side of the machine and is designed to chip the larger, heavier materials that the Shredder Hopper isn't designed to handle. The revolving Chipper Knife mounted on a Rotor turns branches fed into the Hopper into “chips”. The Chipper can chip twigs and branches ranging in size from 1" to 5" in diameter. Cut your materials into manageable lengths of no more than five or six feet long **before** feeding them into the Chipper Hopper.

### WARNING

The Chipper Hopper must be securely bolted to the side of your DR PRO-XL CHIPPER-SHREDDER before using the machine!

- Feed the branch into Chipper Hopper keeping the branch at the same angle as the Chipper Hopper.
- As the branch becomes short and is at the outside edge of the Chipper Hopper, finish processing it by pushing it in with the next branch.
- Do not force material into the Chipper. If the machine does not chip well, the Chipper Knife may need sharpening or replaced, or the gap between the Knife and the Wear Plate needs adjusting.
- Extremely hard knots will not process very well. Push any short stubs that have not self-fed through the Chipper with the next branch to be chipped.

### NOTICE

Never throw remaining stubs or knots into the Shredder Hopper; damage will result.

- Overloading the Chipper Hopper will cause the rotor speed to decrease. If you hear the Engine RPM decreasing, stop feeding material into the Chipper Hopper until the Engine has returned to full speed.
- NEVER allow processed material to build up within 3" of the Discharge opening. Move the PRO-XL CHIPPER-SHREDDER or the pile as needed. Failure to do so could result in unnecessary jamming of the machine.
- To move a pile of processed material, first shut off the Engine, and use a spade, rake, or long handle tool; NEVER use your hands or feet!

### NOTICE

If you jam the machine and do not stop the Engine, it can damage the machine. This damage can be costly and not covered under warranty. See “To Free a Jammed Rotor”.

## Using the Shredder Hopper

The Shredder Hopper is located on the top of the DR PRO-XL CHIPPER-SHREDDER and is the opening into which all materials to be shredded should be fed. You can shred most organic materials. A flexible Blowback Shield is attached to the Hopper. You must push material past this flap using a wooden stick in order to enter the main Shredding Chamber where revolving steel Hammers do the shredding.

### CAUTION

The Blowback Shield is an important feature; it prevents kickback of materials! Do not use your machine unless the Blowback Shield is securely fastened in place.

Due to the wide variety of materials that you can shred, and their very different physical characteristics, only feed limited quantities of any material into the Shredder Hopper at first. Increase the amount and length of material if you find that the material is processing without any difficulty. Your judgment and operator experience is very important. Be sure not to overload the machine by feeding too much material into the Hopper at one time. If you hear the speed of the Engine decreasing, stop feeding material into the machine at once. Do not resume feeding the machine until the Engine has returned to full speed.

- The maximum diameter of material that you can shred is 1-1/2" (including knots). Feed any larger material through the Chipper Hopper. Material larger than 1-1/2" can cause serious damage to any of the internal parts of the Shredding Chamber. Inspect the DR PRO-XL CHIPPER-SHREDDER after every use for bent Hammers, missing Spacers, clogging, or damage to the Screen or any other obvious problems. If damage occurs, the Rotor Assembly can become unbalanced causing excessive vibration. If used in this condition, damage can occur. Do not use the machine if vibration is present. Vibration is generally a warning sign of trouble.
- You can feed several small branches into the Shredder Hopper at once providing their combined diameter is less than 1-1/2". Cut branches so they are shorter than three feet to make them more manageable.
- Allow green or wet materials to dry, or process in small batches with dry materials to avoid clogging or winding around the Rotor Assembly
- Wet materials will clog the machine easily.
- If clogging with wet material continues to occur, stop the Engine and remove the Screen to process material without it. Although processing in this way will reduce the amount of reduction, it will reduce clogging.

#### MATERIALS BEST SUITED FOR SHREDDING

Leaves	Flowers	Corn Stalks	Roots
Soil	Palm frond tops	Grass clippings	Garden debris
Potato vines	Straw and Hay	Hedge clippings	Tomato vines
Manure	Kitchen Waste	Small branches	Paper

### WARNING

The Hammers within the Shredding Chamber can tug suddenly at material fed into the Shredder Hopper. Do not hold on tightly to branches and vines, and do not feed material straight down into the Hopper with your arm pointing downward toward the opening. Instead, keep your arms parallel to the ground and several inches above the top edge of the Hopper.



## To Free a Jammed Rotor

### **WARNING**

Before performing any maintenance procedure or inspection, stop the Engine, wait five minutes to allow all moving parts to come to a complete stop and cool. Disconnect the Spark Plug Wire, keeping it away from the Spark Plug.

- Check and Remove any material left in the Chipper and Shredder Hoppers, using a Wooden Stick.
- Start the machine and allow any remaining material in the Chipping/Shredding Chamber to discharge.
- If the Chipping/Shredding Chamber does not clear and the Rotor is still jammed, the Shredder Chamber will need to be cleared. See “To Clean Out a Clogged Shredder Chamber”
- Be certain the Shredding Chamber is clear before trying to process more material into the Hopper(s). Clogging could result in Belt or Clutch failure.

## To Clean Out a Clogged Shredder Chamber

### Tools Needed:

- Two 9/16" Wrenches

1. Remove the Bolt and Lock Nut securing the Housing Top Plate using two 9/16" Wrenches (**Figure 15**).
2. Remove the Upper Screen Bolt and Lock Nut using two 9/16" Wrenches.
3. Loosen (but do not remove) the Screen Pivot Bolt, Upper Scroll Bolt and Lower Scroll Bolt using two 9/16" Wrenches.
4. Rotate the Housing Top Plate up towards the Hopper, exposing the Screen (**Figure 16**).
5. Rotate the Screen down exposing the Shredder Hammer Assembly.
6. Remove any debris wrapped around the Rotor Components or collected in the Shredding Chamber or Screen (**Figure 17**).
7. Reposition the Screen and reinstall the Upper Screen Retaining Bolt and Lock Nut. Tighten the Upper and Lower Screen Bolts (**Figure 15**).
8. Reposition the Housing Top Plate and secure with the Housing Top Plate Bolt and Lock Nut.
9. Tighten the Lower and Upper Scroll Bolts.
10. Reconnect the Spark Plug Wire, start the machine, and allow any remaining material in the Shredding Chamber to discharge.
11. If the Shredding Chamber does not clear, repeat the above process.

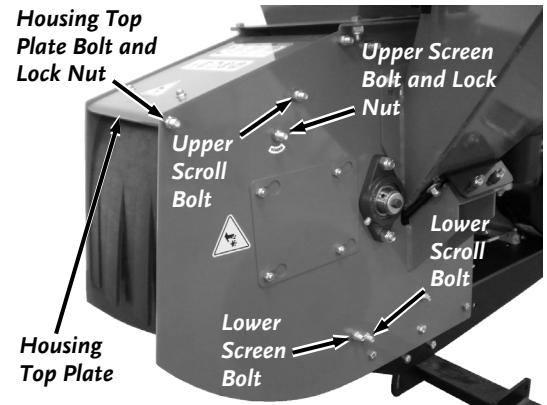


Figure 15

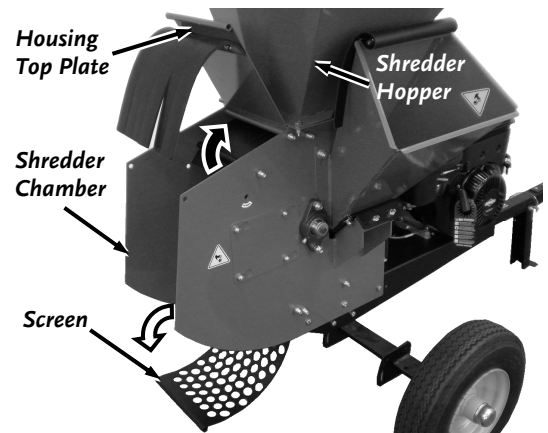


Figure 16

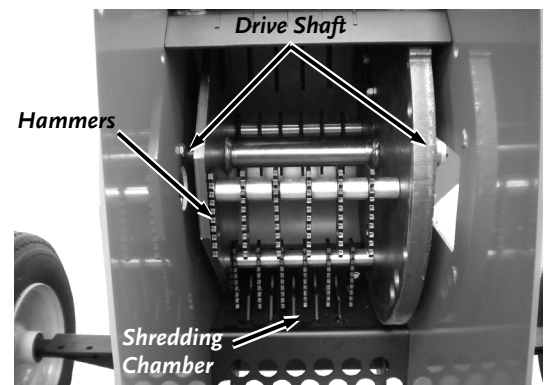


Figure 17

### **NOTICE**

Be certain the Shredding Chamber is clear before trying to process more material into the Hopper. Clogging could result in Belt or Clutch failure.

## Chapter 4: Maintaining the PRO-XL CHIPPER-SHREDDER

Regular maintenance is the way to ensure the best performance and long life of your machine. Please refer to this manual and the Engine Manufacturer's Owner's Manual for maintenance procedures. Service intervals listed in the checklist below supersede those listed in the Engine Manufacturer's Owner's Manual.

### **WARNING**

Before performing any maintenance procedure or inspection, stop the Engine, wait five minutes to allow all parts to cool. Disconnect the Spark Plug Wire, keeping it away from the Spark Plug.

### **Regular Maintenance Checklist**

**NOTE:** Consider that the service intervals shown are the maximum under normal operating conditions. Increase frequencies under extremely dirty or dusty conditions.

Procedure	Before Each Use	Every 25 Hours	Every 40 Hours
Check Engine Oil Level	▲		
Check General Equipment Condition	▲		
Check that the Rotor Shaft turns freely (with a long stick only)	▲		
Inspect Knife for damage	▲		
Clean Engine Exterior and Cooling Fins	▲		
Check the Tire Pressure	▲		
Inspect Air Filter and Foam Pre-cleaner	▲		
Check Knife for Sharpness		▲	
Check Rotor Hammers/Spacers for Wear		▲	
Change Engine Oil	1 <sup>st</sup> time 5 hours	▲	
Check Belt Tension	1 <sup>st</sup> time 1 hour	▲	
Inspect Drive Belts. Replace as needed		▲	
Inspect Spark Plug		▲	
Check/adjust Knife to Wear Plate Gap		▲	
Replace Spark Plug			▲
Check Knife and Wear Plate Attachment Screws			▲
Check Side Bearing Collar Set Screws			▲
Lubricate Side Bearings			▲

## Removing and Replacing the Engine Oil

### Tools and Supplies Needed:

- Rags
- 12mm Wrench
- Small Funnel
- Approved Container (for Waste Oil)
- Engine Oil (see your Engine Manual for Oil specifications)

<b>Engine Oil</b>	SAE 30 Oil - 37 oz. (1.09 L): above 50 degrees F; 10w-30: 30-90 degrees F; 5w-30: 30 degrees F or below
-------------------	---

**Note:** Drain the Oil when the engine is warm. Warm Oil drains quicker and more completely.

1. Position an Approved Container under the Engine Oil Drain Slot (**Figure 18**)
2. Remove the Engine Oil Check/Fill Cap (**Figure 19**).

**Note:** There is an Oil Drain Baffle installed Under the Oil Drain Slot that will divert the Oil to the left side of the Frame when draining.

3. Remove the Oil Drain Plug using a 12mm Wrench. Allow the used Oil to drain completely and then replace the Oil Drain Plug.
4. Initially add 1/2 of the SAE 30 High Detergent Oil recommended by the Engine Manufacturer and wait one minute for the Oil to settle
5. Screw the Dipstick in and then remove it to check the Oil level (clean the Dipstick with a rag after checking) and continue adding a few ounces of oil at a time, rechecking the Dipstick until the Oil reaches the FULL mark. Be careful not to overfill.
6. Replace the Dipstick and screw all the way in when full.

**Note:** Be sure to use environmentally safe procedures when disposing of the used Oil.

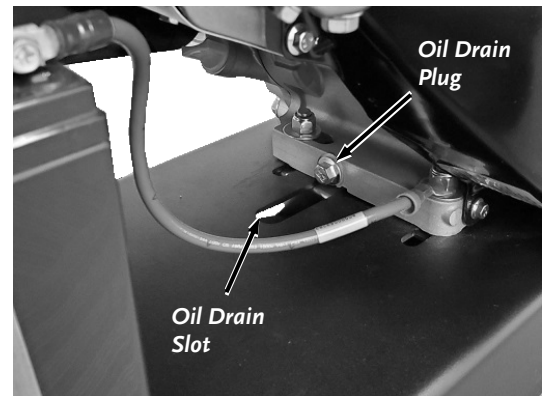


Figure 18

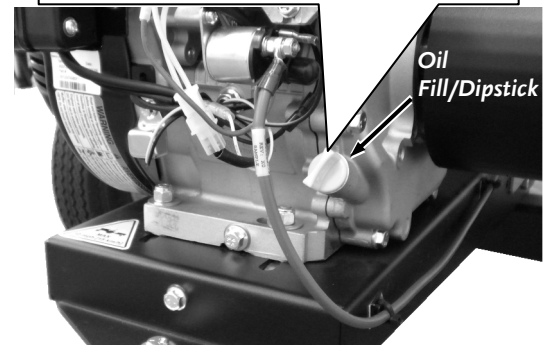
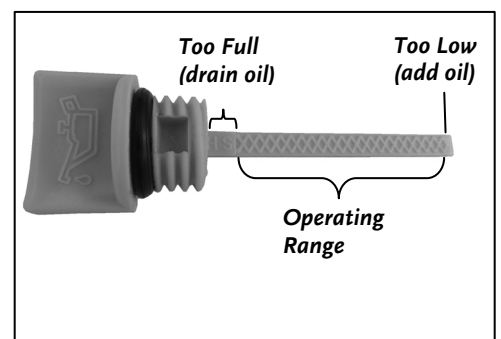


Figure 19

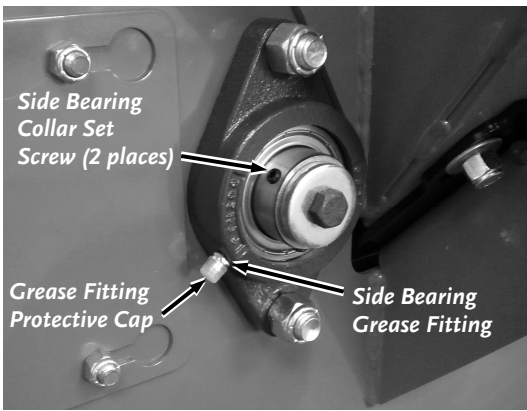


Figure 20



Figure 21

## Grease Fittings

Your PRO-XL CHIPPER-SHREDDER was greased at the Factory. The operator needs to lubricate the Chipper Side and Drive Side Bearings every 40 hours of use.

### Tools and Supplies Needed:

- Flexible hose grease gun
- Lithium grease
- Clean cloth
- 1/8" Allen Wrench

1. Remove the Grease Fitting Protective Cap (**Figure 20**).
2. Wipe all dirt, etc., from the Grease Fitting(s) with a clean cloth.
3. Apply no more than three pumps of quality general-purpose lithium grease with a hand-pumped grease gun to each Grease Fitting, one on the Chipper Side Bearing, and one on the Drive Side Bearing (not shown). To access the Drive Side Bearing, you will have to remove the Belt Guard (see Drive Belt Maintenance section).

## NOTICE

Over lubrication can damage Bearings.

4. After greasing, check the Side Bearing Collar Set Screws for tightness with a 1/8" Allen Wrench. There are two Set Screws per Bearing
5. Replace the Grease Fitting Protective Cap.

## Checking the Tire Pressure

### Tools Needed:

- Tire Pressure Gauge
- Air Compressor with hose

1. Remove the Valve Stem Cap (**Figure 21**).
2. Check the Tire Pressure per the manufacturers recommended pressure stamped on the side of the Tire using a Tire Pressure Gauge.
3. If the pressure is too low, add air through the Valve Stem using an Air Hose.

## ! WARNING

Do not over inflate the Tires. Inflate to the manufacturers recommended pressure found on the Tires.

4. Replace the Valve Stem Cap.

## Removing, Replacing and Adjusting the Drive Belts

### Tools Needed:

- 9/16" Wrench
- 3/8" Wrench
- 1/2" Wrench
- Tape Measure
- Straightedge

### CHECKING AND ADJUSTING BELT TENSION

**Note:** The DR PRO-XL CHIPPER SHREDDER has two drive Belts. Due to factory tolerances the tension on the two Belts may differ slightly. Over time the Belts will stretch and will begin to closely match each other. This procedure only needs to be performed on one Belt.

1. Remove the three Bolts supporting the Belt Guard using a 3/8" Wrench (**Figure 22**). Remove the Belt Guard and set aside.
2. Place a Straightedge on the bottom of the Belt from the Clutch Pulley to the Drive Pulley (**Figure 23**).
3. Push up on the Belt using approximately ten pounds of force. The Belt should deflect away from the Straightedge approximately 3/8".
4. If the Belt deflection is close to the 3/8" as desired, adjustment is not needed. If it is not close to 3/8", continue to the next step.
5. Loosen the four Engine Bolts (two in the Front and two in the Rear) using a 9/16" Wrench (**Figure 24**).
6. Tighten (turning clockwise) or loosen (turning counter clockwise) the Tension Adjuster Bolt using a 1/2" Wrench to get the proper tension as described in Step 3.
7. Tighten the Engine Lock Nuts.
8. Re install the Belt Guard.

**Note:** Check and re-tighten the Drive Belts, every hour for the first 5 hours of operation when a new Belt has been installed.

### REMOVING AND REPLACING THE BELTS

When your DR PRO-XL CHIPPER SHREDDER's Belts are no longer adjustable or are frayed, cut or damaged, replace them with new DR Belts.

1. Remove the three Bolts supporting the Belt Guard using a 3/8" Wrench (**Figure 22**). Remove the Belt Guard and set aside.
2. Loosen the four Engine Lock Nuts (two in the Front and two in the Rear) using a 9/16" Wrench (**Figure 24**).
3. Loosen the Tension Adjuster Bolt, using a 1/2" Wrench and create enough slack in the Belts to remove them from the Clutch and Drive Pulley (**Figure 23**).
4. Install the new Belts onto the Drive Pulley and Clutch Pulley.
5. Re-tension the Belt per the Previous instructions "Checking and Adjusting Belt Tension".
6. Tighten the Engine Lock Nuts (**Figure 24**).
7. Re-install the Belt Guard (**Figure 22**).

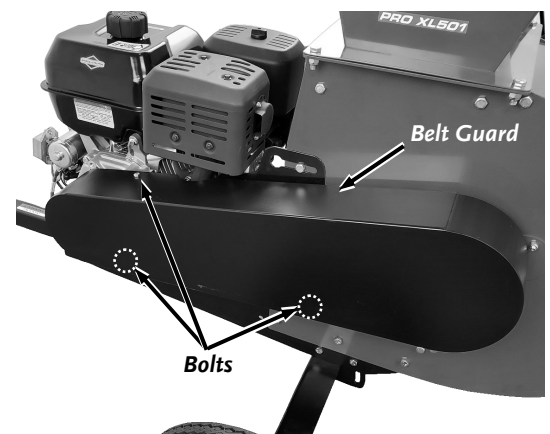


Figure 22

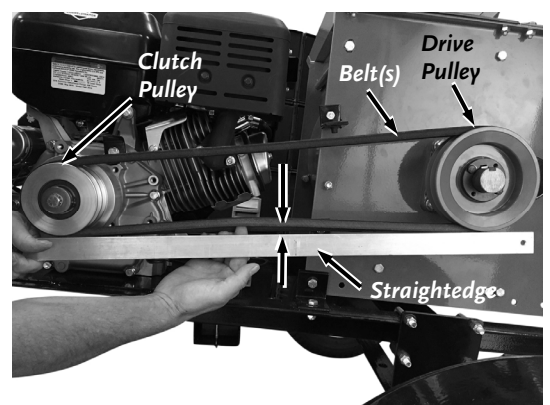


Figure 23

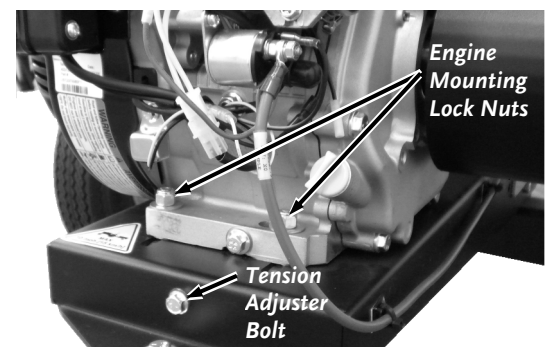


Figure 24

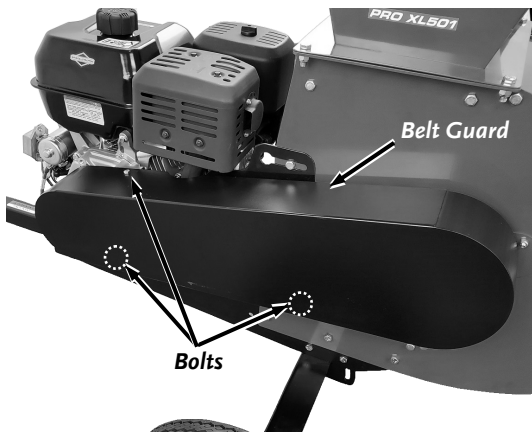


Figure 25

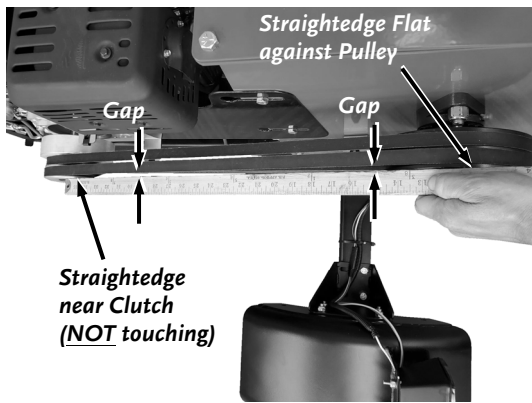


Figure 26

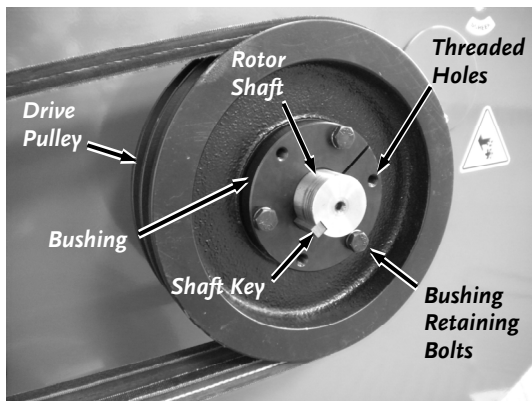


Figure 27

## BELT ALIGNMENT

### Tools Needed:

- 7/16" Wrench
- Straightedge
- Tape Measure

1. Remove the three Bolts supporting the Belt Guard using a 3/8" Wrench (**Figure 25**). Remove the Belt Guard and set aside
2. Check the alignment between the Clutch and the Drive Pulley by placing one end of a Straightedge flat against the face of the Drive Pulley with the other end near the top portion of the Clutch (next to the Belt but not touching the Clutch) (**Figure 26**).
3. The Gap measurement between the Straightedge and Belt should be the same at both ends (the Straightedge should be parallel with the Belt). If the straight edge and Belt are parallel, no adjustment is needed. If the straight edge and Belt are not parallel, continue to the next step.

4. Remove the three Bushing Retaining Bolts with a 7/16" Wrench (**Figure 27**).

**Note:** The Bushing has six holes. Three holes for securing the Pulley to the Bushing (threads are in the Pulley) and three holes for separating the Pulley from the Bushing (threads are in the Bushing).

5. Reinstall the three Bolts in the Threaded Holes adjacent the three holes you just removed the Bolts from.
6. Slowly tighten the Bolts about a 1/4 to 1/2 turn evenly and alternately until the Bushing releases from the Rotor Shaft.
7. When the Pulley is loose, remove the three Bolts and reinsert them into the original Retaining Bolt Holes by hand.
8. Using the Straightedge, align the Clutch and Pulley by moving the bushing in or out on the Rotor Shaft.

**Note:** The Pulley will move slightly onto the Bushing when tightening the Bolts. You may need to compensate for this movement when positioning the Bushing on the Shaft.

9. Slowly tighten the Bushing Retaining Bolts evenly and alternately (1/4 to 1/2 turn). The bolts only need to be snug. Do not over tighten.
10. Recheck the Belt alignment and repeat alignment procedures as needed.
11. Reinstall the Belt Guard (**Figure 25**).

## Check and Adjusting the Knife to Wear Plate Gap

When you replace the Knife, check and set the clearance between the Knife and Wear Plate. Use the Gap Gauge provided with your machine to set this clearance to 1/16" (**Figure 28**). If the gap between the Wear Plate and the Knife is not set correctly, you will have excessive vibration when chipping and the Knife will seem to be dull. The Wear Plate should have a square edge and be free of dents or gouges. The Wear Plate can be hand filed to square the edges. Be careful not to overheat it during the sharpening process as this will change the characteristics of the steel and you will then have to replace the Wear Plate.

### Tools Needed:

- Two 5/16" Wrenches
- 9/16" Wrench
- Stick
- Gap Gauge (provided with machine)

1. To prevent accidental Starter engagement, disconnect the Battery Negative Terminal using two 5/16" wrenches.
2. You can gain access to the Chipper Knife and Wear Plate By tucking the Blowback Shield between the Shredder Hopper and the Chipper Hopper (**Figure 29**)
3. Using a stick, rotate the Chipper Disk until the Knife is opposite the Wear Plate (**Figure 30**).
4. Slide the Gap Gauge between the Knife and Wear Plate. If the gap is set correctly, the Gap Gauge will lightly touch both the Knife and Wear Plate. If the gap is too small, you will not be able to get the Gauge between the Knife and Wear Plate. If the gap is too large, there will be excess room between Gap Gauge, Knife, and Wear Plate.
5. To adjust the Wear Plate Gap:
  - a. Loosen the three Lock Nuts that secure the Wear Plate to the Chipper Hopper using a 9/16" Wrench (**Figure 31**).
  - b. Loosen the two Adjuster Lock Nuts on the Wear Plate using a 9/16" Wrench.
  - c. To tighten the gap, bring the Wear Plate closer to the Knife by turning the Adjuster Jam and Lock Nuts clockwise using a 9/16" Wrench. Tighten the Adjuster Jam Nut and check the gap.
  - d. To Increase the gap, bring the Wear Plate away from the Knife by turning the Adjuster Jam and lock Nuts counter clockwise using a 9/16" Wrench. Tighten the Adjuster Lock Nuts and check the gap.
6. When the Knife gap is set, and the Wear Plate is in the correct position, tighten the Wear Plate Lock Nuts using a 9/16" Wrench.

**Note:** Be sure to check and set the gap equally along the Wear Plate and Knife.

**Note:** After any Knife or Wear Plate maintenance or adjustment, rotate the Rotor Disk with a Stick and watch and listen carefully for any unusual noises, clicking or vibration. If you detect any of these, inspect the machine for damage, or any loose parts. Repair or replace any damaged parts and tighten any loose parts before starting the DR PRO-XL CHIPPER-SHREDDER.

7. Re-connect the Negative Battery Terminal Wire and Spark Plug Wires.

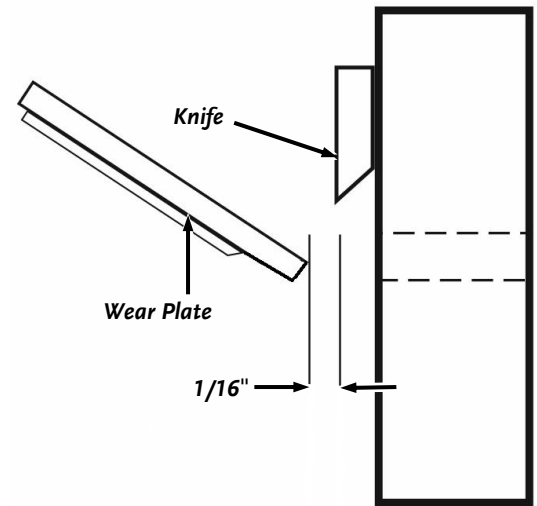


Figure 28

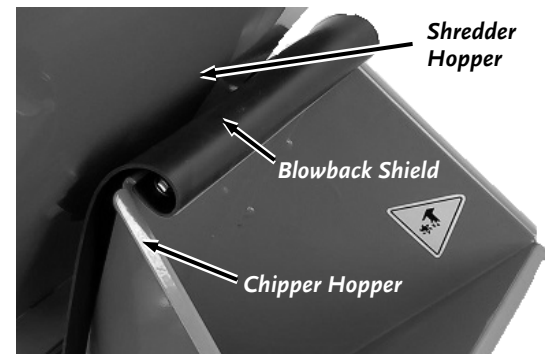


Figure 29

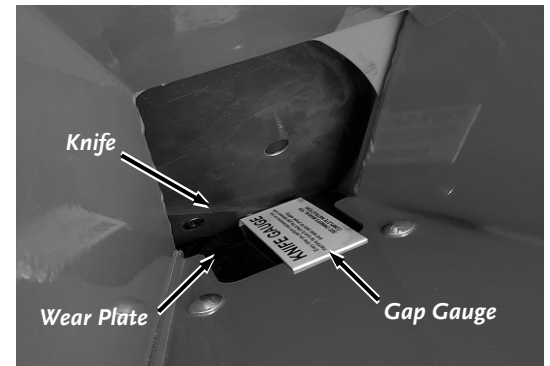


Figure 30

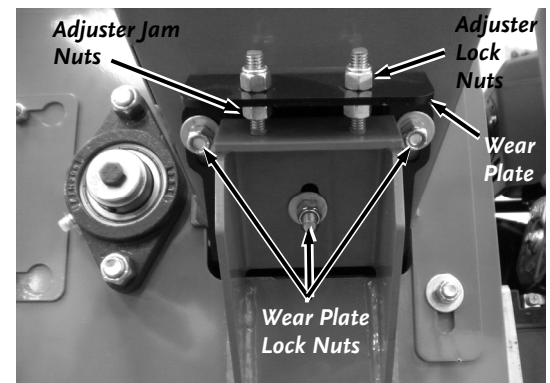


Figure 31

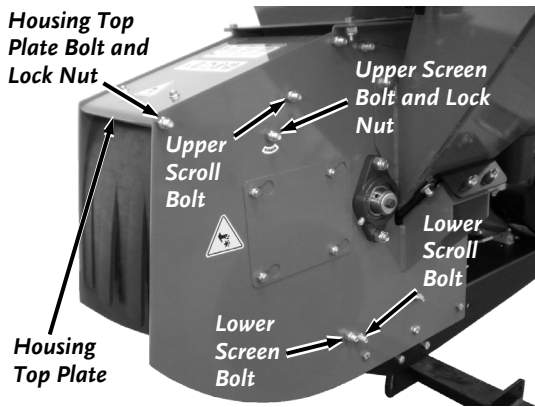


Figure 32

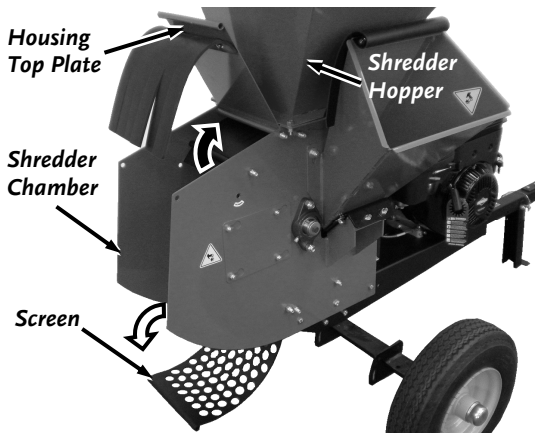


Figure 33

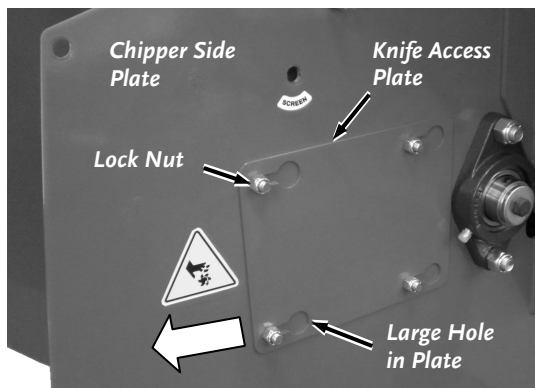


Figure 34

## Removing and Replacing the Chipper Knife

### Tools and Supplies needed:

- 3/16" Allen Wrench
- Awl or Sharp Tool
- 1/2" Wrench
- Two 9/16" Wrenches
- Gloves

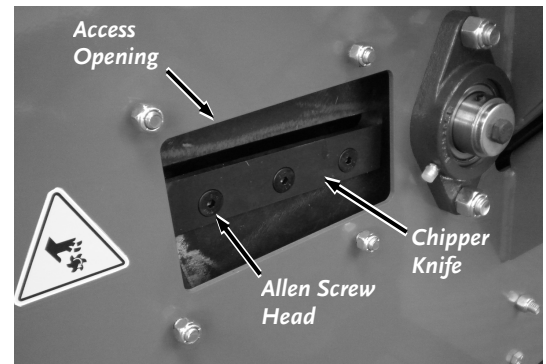
1. To prevent accidental Starter engagement, disconnect the Battery Negative Terminal using two 5/16" wrenches, and disconnect the Spark Plug Wire.
2. Remove the Bolt and Lock Nut securing the Housing Top Plate using two 9/16" Wrenches (**Figure 32**).
3. Remove the Upper Screen Bolt and Lock Nut using two 9/16" Wrenches.
4. Loosen (but do not remove) the Screen Pivot Bolt, Upper Scroll Bolt and Lower Scroll Bolt using two 9/16" Wrenches.
5. Rotate the Housing Top Plate up towards the Hopper, exposing the Screen (**Figure 33**).
6. Rotate the Screen down exposing the Shredder Hammer Assembly
7. Loosen the four Lock Nuts that hold the Knife Access Plate to the Chipper Side Plate, using a 1/2" Wrench (**Figure 34**).
8. Slide the Knife Access Plate over to align the Lock Nuts with the large holes in the Knife Access Plate and remove the Knife Access Plate.



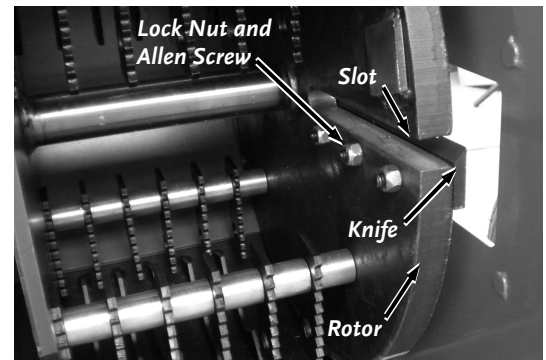
9. Rotate the Rotor Assembly using a Stick until the three Allen Screws attaching the Knife to the Rotor are visible through the Access Opening (**Figure 35**).
10. Clean out the heads of the Allen Screws with an Awl or Sharp Tool.
11. Insert a 3/16" Allen Wrench into the head of the Allen Screw and remove the Lock Nut using a 1/2" Wrench (**Figure 36**).
12. Repeat Step 11 for the remaining two Allen Screws and Lock Nuts.
13. Remove the dull or damaged Knife and visually inspect the Rotor Slot and Knife mounting area to be sure they are clean. Metal burrs may need filing so that the replacement Knife will be able to mount flush against the Rotor.
14. Install a new or sharpened Knife and finger tighten the Allen Screws and Lock Nuts that hold the Knife to the Rotor.

**Note:** If installing a new Chipper Knife, the new Knife will come with mounting hardware, discard the used hardware.

15. Tighten the center Allen Screw and Lock Nut first, then tighten the outer Screw, and finally tighten the inner Screw using a 3/16" Allen Wrench and 1/2" Wrench.
16. Double-check all three Screws and Lock Nuts for tightness one more time.
17. Reinstall the Knife Access Plate (**Figure 34**).
18. Reposition the Screen and reinstall the Upper Screen Retaining Bolt and Locknut. Tighten the Upper and Lower Screen Bolts (**Figure 33**).
19. Reposition the Housing Top Plate and secure Bolt and Lock Nut (**Figure 32**).
20. Tighten the Lower and Upper Scroll Bolts.
21. Check the gap between the Knife and Wear Plate and adjust if required per the instructions described in "Check and Adjusting the Knife to Wear Plate Gap".
22. Re-connect the Negative Battery Terminal Wire and Spark Plug Wires.



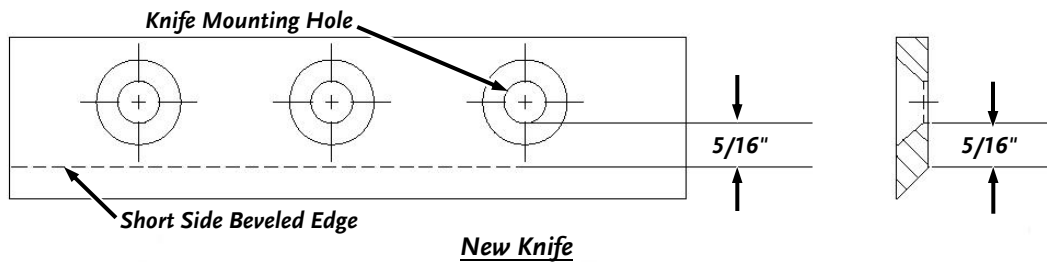
**Figure 35**



**Figure 36**

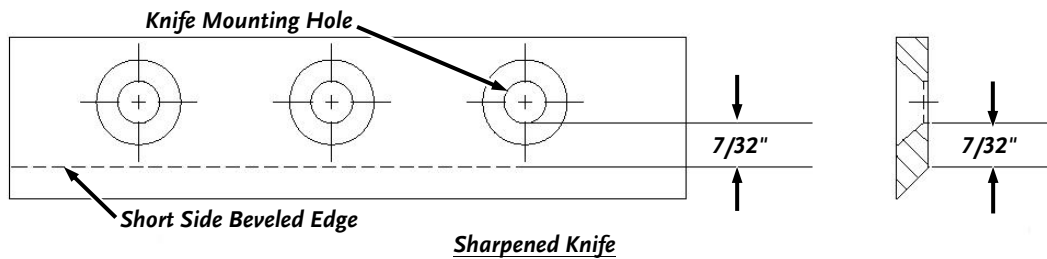
## Knife Sharpening

- You should never attempt to sharpen the Chipper Knife freehand; take the Knife to a machine shop for proper sharpening.
- It is extremely important to consistently maintain the 45-degree angle for proper performance.
- Excessive heat generated during the sharpening process will damage Knives and weaken the metal.
- How many times a Knife can be sharpened is determined by how much material needs to be taken off to sharpen or to compensate for dents or gouges.
- A new Chipper Knife has a  $5/16$ " measurement between the short side bevel edge and the Knife mounting holes (**Figure 37**).

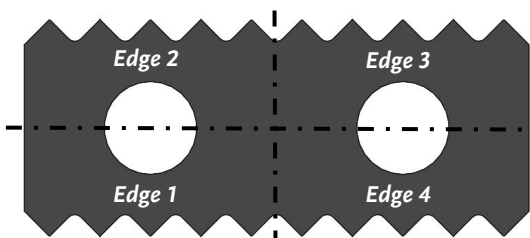


**Figure 37**

- The Knife should never be sharpened to the extent that more than  $3/32$ " is taken off this measurement.
- Once this measurement is below  $7/32$ " (**Figure 38**), or if you are unable to remove dents or gouges with these guidelines, replace the Knife.



**Figure 38**



**Figure 39**

## Adjusting the Shredder Hammers

When the hard steel Hammers of the Rotor Assembly become dull or round on the cutting edge, they may be rotated (side to side) or reversed (end to end), to expose a new cutting edge.

**Note:** The Hammers have four cutting edges that may be used before replacement is necessary (**Figure 39**). To rotate or reverse the Hammers, proceed as follows:

### Tools and Supplies Needed:

- Retaining Ring Pliers
- Two  $7/16$ " Wrenches
- Two  $9/16$ " Wrenches
- $3/8$ " Wrench
- Marker or Tape
- Vise Grips

1. Remove the three Bolts supporting the Belt Guard using a 3/8" Wrench (**Figure 40**). Remove the Belt Guard and set aside.
2. Remove the Bolt and Lock Nut securing the Housing Top Plate using two 9/16" Wrenches (**Figure 41**).
3. Remove the Upper Screen Bolt and Lock Nut using two 9/16" Wrenches.
4. Loosen (but do not remove) the Screen Pivot Bolt, Upper Scroll Bolt and Lower Scroll Bolt using two 9/16" Wrenches.
5. Rotate the Housing Top Plate up towards the Hopper, exposing the Screen (**Figure 42**).
6. Rotate the Screen down exposing the Shredder Hammer Assembly
7. Loosen the four Lock Nuts that hold the Knife Access Plate to the Chipper Side Plate, using a 1/2" Wrench (**Figure 43**).
8. Slide the Knife Access Plate over to align the Lock Nuts with the large holes in the Knife Access Plate and remove the Knife Access Plate.
9. Loosen the Lock Nut and Bolt that holds the Hammer Access Plate to the Side Plate using two 7/16" Wrenches. Rotate the Plate upward to expose the Access Window (**Figure 44**).
10. Tighten the Bolt and Lock Nut to hold the Hammer Access Plate out of the way.

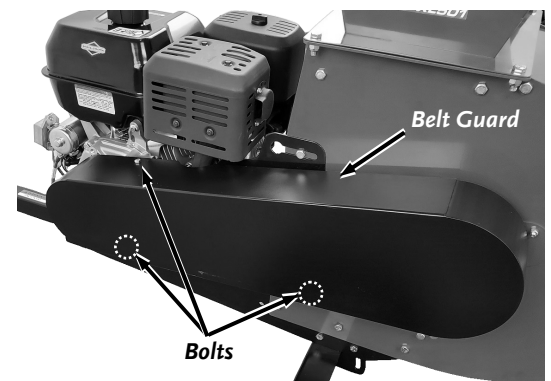


Figure 40

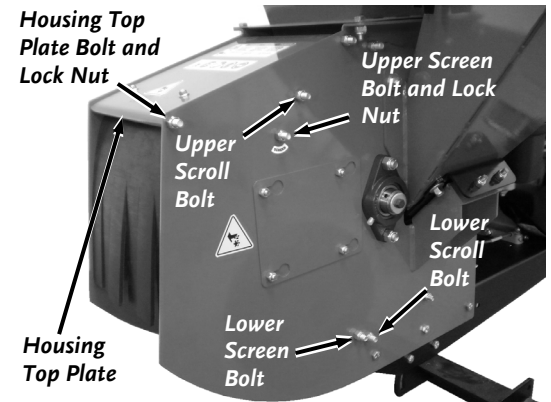


Figure 41

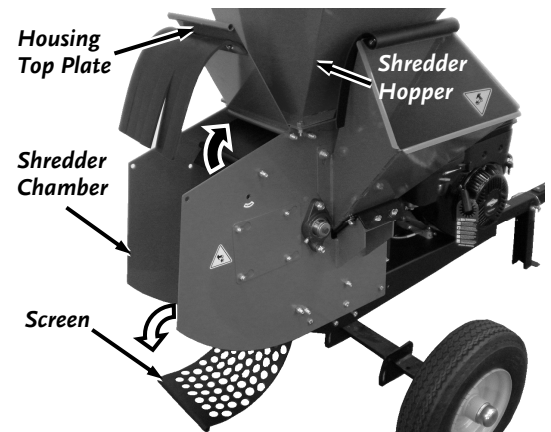


Figure 42

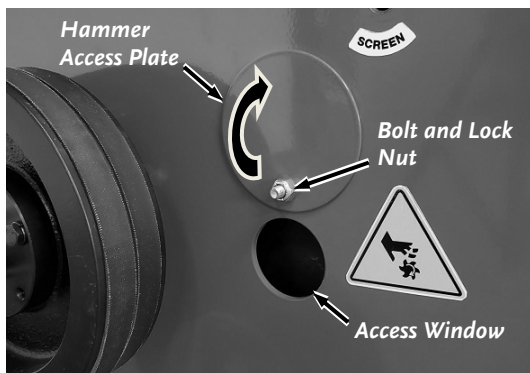


Figure 44

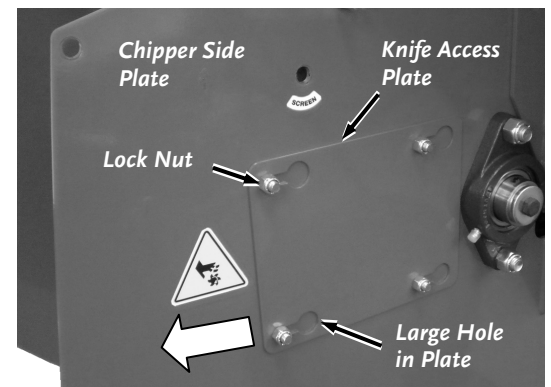


Figure 43

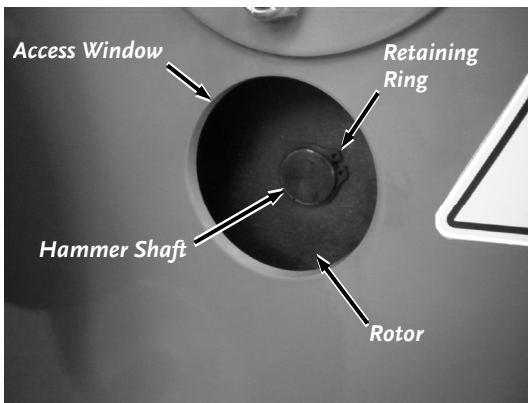


Figure 45

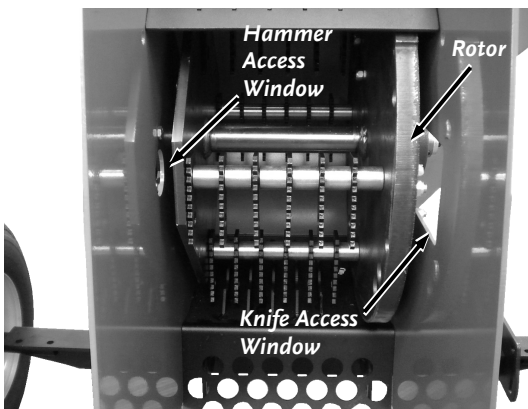


Figure 46

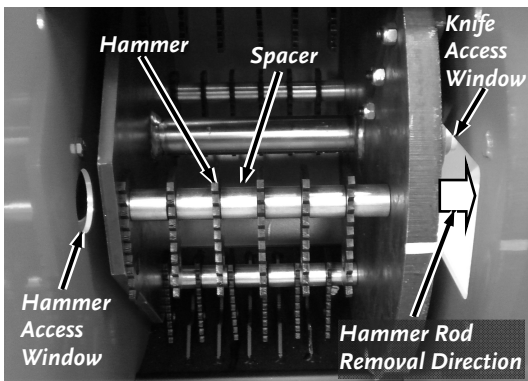


Figure 47

11. Use a Stick to rotate the Rotor until the Hammer Shaft (**Figure 45**) is lined up with the Hammer and Knife Access Windows (**Figure 46**).

12. Remove the Retaining Ring that holds the Hammer Shaft to the Rotor, using Retaining Ring Pliers (**Figure 45**).

**Note:** Do not over stretch the Retaining Ring. Only open the Ring enough to clear the Hammer Rod.

13. Slowly remove the Hammer Rod through the Knife Access Window, while at the same time removing the Hammers and Spacers from the Rod, setting them aside in the same order and orientation as you removed them (**Figure 47**).

14. Reverse each Hammer (end to end) to the opposite hole in the Hammer. If you have already reversed the Hammers (end to end), rotate each Hammer (side to side) on the same mounting hole.

15. Slide the Rod back through the Knife Access Window, into the Rotor and reinstall the Hammers and Spacers in the same order as removed.

16. Replace the Retaining Ring using Retaining Ring Pliers, making sure that the Retaining Ring is secured in the groove.

**Note:** Be sure to reinstall the Hammers and Spacers in exactly the same order that they were removed. Refer to the Shredder Assembly Schematic on page 35 for the correct order.

17. Repeat steps 11 through 16 for the remaining three Hammer Rods.

**Tip:** To remember which Hammer Rod you have reworked, it may be helpful to mark the end of the Hammer Rods with a Marker or Tape.

18. Reposition the Hammer Access Window (**Figure 44**).

19. Reinstall the Knife Access Plate (**Figure 43**).

20. Reposition the Screen and reinstall the Upper Screen Retaining Bolt and Lock Nut. Tighten the Upper and Lower Screen Bolts (**Figure 42**).

21. Reposition the Housing Top Plate and secure with the Housing Top Plate Bolt and Lock Nut (**Figure 41**).

22. Tighten the Screen Pivot Bolt, Upper Scroll Bolt and Lower Scroll Bolt.

23. Reinstall the Belt Guard (**Figure 40**).

## Removing and Replacing the Clutch

The design of the Clutch on your machine is for rugged, dependable service, however, it is important to understand the limitations of a Clutch. The Clutch provides load free starting of the Engine and provides slippage under excessive overloading of the driven application. These features help protect the Engine from damages such as broken crankshafts and starters. The Clutch on this machine is permanently lubricated and does not require oil or grease. The Drum, Shoes, and Springs in the Clutch are normal wear items. If you notice decreased performance of the Clutch, check and replace it if necessary.

The Clutch obtains its power from the Engine RPM. The higher the maintained Engine speed, the more torque the Clutch can transfer to the driven unit. **NEVER operate the DR PRO-XL CHIPPER-SHREDDER Engine at less than full RPM.**

### NOTICE

- Do not tamper with the Engine's Governor setting. The governor controls the maximum safe operation speed and protects the Engine. Over-speeding the Engine is dangerous and will cause damage to the Engine and to the other moving parts of the machine. See your authorized dealer for any Engine Governor adjustments.
- Become familiar with successful operating conditions and avoid those that can overload and damage the machine.
- Do not overload or attempt to chip material beyond manufacturer's recommendation. Personal injury or damage to the machine could result. Learn to recognize the sound of the machine during an overload condition. Only your operator experience will tell you how fast you can successfully feed material into the machine.
- If overloading or any other cause jams the machine, stop the machine immediately. If you jam the machine and do not stop the Engine, it can burn the Drive Belts and/or ruin the Clutch. Clutch damage can be costly, and it may not be covered under warranty. For this reason, it is important that you immediately shut off the machine if it becomes jammed.
- The Centrifugal Clutch on this machine is permanently lubricated and does not require Oil or Grease. If, after long periods of use, the Drum wobbles excessively, replace the Clutch assembly.

**Note:** At Engine start-up, the Engine of your Chipper-Shredder operates under no load until approximately 1800 RPM, at which speed the Centrifugal Clutch engages and begins driving the Rotor.

### Installing a new Clutch Assembly

#### Tools and Supplies Needed:

- 5/8" Wrench or Air Wrench and 5/8" Socket
- Anti-seize compound

1. Remove the Belt Guard and Belt (see "Removing and Replacing the Drive Belt" in this Chapter).

**Note:** You may need to use an Air Wrench to break the Clutch Bolt loose depending how tight it is on the Engine shaft.

2. Remove the Clutch Bolt, Lock Washer and Flat Washer, using a 5/8" Wrench (**Figure 48**).
3. Remove the Clutch from the Crankshaft.
4. Remove the Key from the keyway in the Engine Crankshaft and set it aside.
5. Clean the Engine Crankshaft and remove any burrs, then apply Anti-seize compound to the Crankshaft.
6. Install the Key in the keyway of the new Clutch Hub, align the Key with the slot in the Engine Crankshaft, and slide the new Clutch Assembly onto the shaft.
7. Secure the Clutch with the Flat Washer, Lock Washer and Clutch Bolt using a 5/8" Wrench.

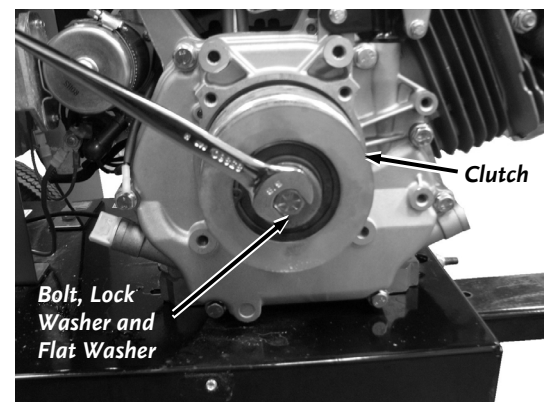


Figure 48

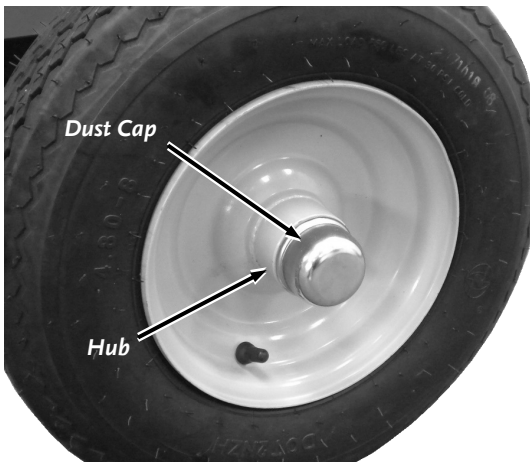


Figure 49

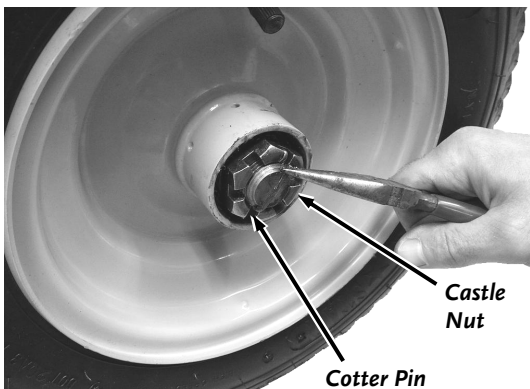


Figure 50

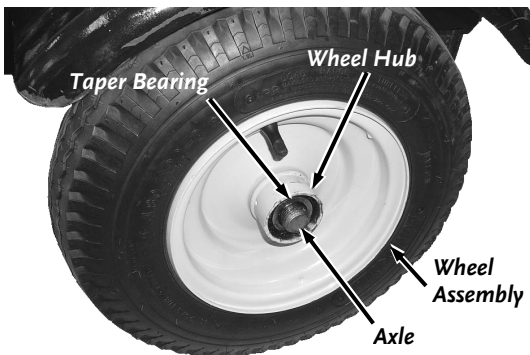


Figure 51

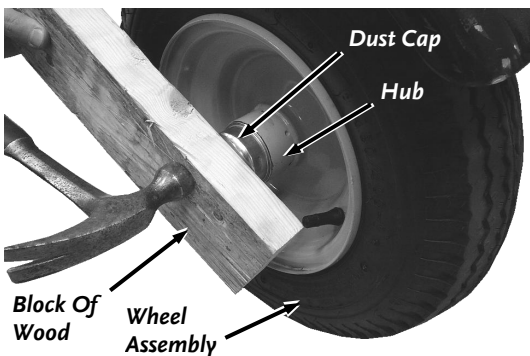


Figure 52

8. Reinstall the Drive Belt and adjust the Drive Belt tension and alignment (see “Removing and Replacing the Drive Belt” in this Chapter).
9. Reinstall the Belt Guard.

### Removing and Replacing the Wheels

The Wheels on the DR PRO-XL CHIPPER SHREDDER are pneumatic and have tapered bearings. With use, Tires and Bearings may need replacing. The following procedure will explain how to replace the Wheel.

#### Tools Needed:

- Needle Nose Pliers
- Flat Tip Screwdriver
- Adjustable Wrench
- Hammer
- Block of Wood
- Jack

1. Jack the Chipper Shredder up and place it on Jack Stands so that the Wheel is off the ground.
2. Pry the Dust Cap off from the Hub, using a Flat Tip Screwdriver (Figure 49).
3. Remove the Cotter Pin, using Needle Nose Pliers (Figure 50).
4. Remove the Castle Nut, using an Adjustable Wrench.
5. Remove the old Wheel Assembly from the Axle and replace it with the new Wheel Assembly (Figure 51).

**Note:** The outer Taper Bearing is loosely inserted into the Wheel Assembly during shipment and may fall out during assembly. Assure that the outer Taper Bearing is installed on the Axle and pushed into the Wheel Hub.

6. Screw the Castle Nut onto the Axle and tighten it with an Adjustable Wrench to seat the Bearings (Figure 50).
7. Loosen the Castle Nut and then snug it up to the Bearing lightly.
8. Insert a Cotter Pin through the slots of the Castle Nut and into the hole in the Axle.
9. Bend the ends of the Cotter Pin with Needle Nose Pliers to secure it.
10. Place the Dust Cap onto the Wheel Assembly and secure it by placing a Block of wood over it and pounding lightly with a Hammer until it is flush against the lip of the Hub on the Wheel Assembly (Figure 52).
11. Jack the back of the Chipper Shredder up and remove the Jack Stands.
12. Lower the Chipper Shredder to the ground.
13. Check the Tire for proper air pressure and adjust as needed.

### **! WARNING**

Do not over inflate the Tires. Inflate to the manufacturers recommended pressure found on the Tires.

## **Battery Care**

Proper care can extend the life of a Battery. Follow these recommendations to ensure your Battery's best performance and long life:

- Do not allow the Battery charge to get too low. If the machine is not used, charge the Battery every 4 – 6 weeks. Operate the Engine for at least 45 minutes to maintain proper Battery charge.
- Store an unused Battery in a dry area that does not freeze.
- Do not charge an already charged Battery. In theory, you cannot overcharge our Battery with a trickle charger; however, when a Battery is fully charged, and the Charger is still on, it generates heat that could be harmful to the Battery. A fully charged Battery will read 12V-13.2V with a voltmeter.
- Do not continue to crank your Engine when the Battery charge is low.

## **Charging the Battery**

Operate the Engine for at least 45 minutes to maintain proper Battery charge. If the Battery loses its charge, you will need to use a trickle charger (like the DR Battery Charger) to recharge it. The Charger should have an output of 12 volts at no more than 2 amps.

- At 1 amp, the Battery may need to be charged for as long as 48 hours.
- At 2 amps, the Battery may need to be charged for as long as 24 hours.

To connect a Battery Charger to your DR PRO-XL CHIPPER-SHREDDER, follow the steps listed below.

1. Attach the black (-) Battery Charger wire to the Battery Negative (-) Terminal and attach the red (+) Battery Charger wire to the Battery Positive (+) Terminal.
2. Plug the Battery Charger into an outlet.

---

### **NOTICE**

When you are finished charging the Battery, disconnect the Charger from the outlet first, then disconnect the Battery Charger wires from the Battery. If you leave the Battery Charger wires connected to the Battery, the Battery will discharge itself back into the Charger.

---

## **Recycling a Used Battery**

Please dispose of your used batteries responsibly by recycling them. Call your local Solid Waste Management District or your local waste handler to locate the collection site nearest you. Some collection sites recycle batteries year-round; others collect them periodically.

You can also visit the Website of Earth 911 for more information ([www.earth911.org](http://www.earth911.org)). Once there, click the Municipal HHW link under Hazardous Household Waste, and enter your zip code. The site lists recycling centers located near you.

For a fee, you can recycle your batteries with the International Metals Reclamation Company. Visit them at [www.inmetco.com](http://www.inmetco.com) and click Services, then click Battery Recycling; or contact them at:

INMETCO, PO Box 720, 245 Portersville Road, Ellwood City, PA 16117  
(724) 758-2800; fax (724) 758-2845

To learn more about hazardous waste recycling, visit the website for Battery Council International ([www.batterycouncil.org](http://www.batterycouncil.org)) or for the Environmental Protection Agency ([www.epa.gov](http://www.epa.gov)).

---

### **NOTICE**

Please dispose of used Batteries responsibly, according to your local hazardous materials regulations. Never throw away used Batteries in your household trash.

---

## Chapter 5: Troubleshooting

Most problems are easy to fix. Consult the Troubleshooting Table below for common problems and their solutions. If you continue to experience problems, contact us at [www.DRpower.com](http://www.DRpower.com) or call toll-free 1-800-DR-OWNER (376-9637) for support.

### **WARNING**

Shut down the Engine, remove the Spark Plug Wire, and wait 5 minutes before performing any maintenance procedure or inspection on the DR PRO-XL CHIPPER-SHREDDER.

### Troubleshooting Table

SYMPTOM	POSSIBLE CAUSE
<p><i>The Engine will not start.</i></p> <p><i>(Please refer to the Engine Owner's Manual for Engine-specific procedures.)</i></p>	<ul style="list-style-type: none"> <li>⇒ Check all the items under the section "Starting the Engine" on page 13.</li> <li>⇒ Check that the Spark Plug Wire is attached.</li> <li>⇒ Check the wire connections—especially the ground connection, the large green wire coming from the Battery, where it connects to the Engine.</li> <li>⇒ Make sure that the Battery is charged. See the Battery Care section on page 33.</li> <li>⇒ The Air Filter may be dirty; change it following the procedure in the Engine Owner's Manual.</li> <li>⇒ The gas may be old; change it if necessary. Use a fuel stabilizer if you keep gas longer than one month.</li> <li>⇒ The Spark Plug may be dirty or cracked; change it if necessary. If it is oily, leave it out, hold a rag over the Plug Hole and crank the Engine several times to blow out any oil in the Cylinder, then wipe off the Plug and reinsert it. NEVER run the Engine with a cracked Spark Plug.</li> <li>⇒ If your Engine still won't start, visit our website at <a href="http://www.DRpower.com">www.DRpower.com</a>.</li> </ul>
<p><i>The Engine lacks power or is not running smoothly.</i></p> <p><i>(Please refer to the Engine Owner's Manual for engine-specific procedures.)</i></p>	<ul style="list-style-type: none"> <li>⇒ Make sure the Choke Lever is pushed in all the way to the RUN position.</li> <li>⇒ Make sure that the Throttle Lever is all the way left to the FAST position.</li> <li>⇒ The Air Filter may be dirty; change it following the procedure in the Engine Owner's Manual.</li> <li>⇒ The Spark Plug may be dirty or cracked; change it if necessary. If it is oily, leave it out, hold a rag over the Plug Hole and crank the Engine several times to blow out any oil in the Cylinder, then wipe off the Plug and reinsert it. NEVER run the engine with a cracked spark plug.</li> <li>⇒ The gas may be old; change it if necessary. Use a fuel stabilizer if you keep gas longer than one month.</li> <li>⇒ The Engine oil may be dirty. Change it if necessary.</li> <li>⇒ Check that the Cooling Fins are clean and free of debris. Clean as needed.</li> <li>⇒ If your Engine still lacks power, visit our website at <a href="http://www.DRpower.com">www.DRpower.com</a>.</li> </ul>
<p><i>Engine smokes.</i></p> <p><i>(Please refer to the Engine Owner's Manual for engine-specific procedures.)</i></p>	<ul style="list-style-type: none"> <li>⇒ Check the oil level and adjust as needed.</li> <li>⇒ You may be operating the machine on too great an incline. The machine should be level.</li> <li>⇒ The Air Filter may be dirty; change it following the procedure in the Engine Owner's Manual.</li> <li>⇒ You may be using the wrong oil - too light for the temperature. Refer to your Engine Owner's Manual for detailed information.</li> <li>⇒ Check that the Cooling Fins are clean and free of debris. Clean as needed.</li> <li>⇒ If your Engine still smokes, visit our website at <a href="http://www.DRpower.com">www.DRpower.com</a>.</li> </ul>



## Troubleshooting Table (Continued)

### WARNING

Shut down the Engine, remove the Spark Plug Wire, and wait 5 minutes before performing any maintenance procedure or inspection on the DR PRO-XL CHIPPER-SHREDDER.

SYMPTOM	POSSIBLE CAUSE
<i>The Engine runs but the Rotor doesn't rotate.</i>	<ul style="list-style-type: none"> <li>⇒ The Throttle Lever should be all the way to the left in the FAST (rabbit) position to engage the Clutch.</li> <li>⇒ The Drive Belts are loose, off, or broken. Reinstall, re-tension, or change Belts (refer to "Chapter 4: Maintaining the DR PRO-XL CHIPPER-SHREDDER").</li> <li>⇒ Remove any built-up debris from the DR PRO-XL CHIPPER-SHREDDER Hopper Inlet(s) and Discharge Chute.</li> <li>⇒ The inner Shoes of the Clutch are worn, and/or the Clutch Shoe Retaining Springs are weak or broken. Change the Clutch (refer to "Chapter 4: Maintaining the DR PRO-XL CHIPPER-SHREDDER").</li> </ul>
<i>Shredding and chipping action seems too slow or Rotor is stalling.</i>	<ul style="list-style-type: none"> <li>⇒ The Engine speed is too slow causing the Belt to slip. Run the Engine at full throttle.</li> <li>⇒ Check for loose or damaged Drive Belt(s); tighten or replace.</li> <li>⇒ Check for a dull or damaged Knife; sharpen or replace the Knife.</li> <li>⇒ Check for a clogged Shredder Screen, clean if necessary.</li> </ul>
<i>Belt frays or falls off frequently.</i>	<ul style="list-style-type: none"> <li>⇒ The Drive Pulley or Clutch groove may be nicked. Check the Drive Belt for wear and hard spots. File off any nicks on the Drive Pulley or Clutch.</li> <li>⇒ The Drive Belt(s) may be stretched; readjust or replace.</li> </ul>
<ul style="list-style-type: none"> <li>- Clutch overheats.</li> <li>- Belt burns.</li> <li>- Rotor won't turn.</li> </ul>	<ul style="list-style-type: none"> <li>⇒ Immediately stop the Engine and remove the Spark Plug Wire.</li> <li>⇒ Turn the Rotor with a wooden stick to be sure it turns freely.</li> <li>⇒ Check the Drive Belt tension.</li> <li>⇒ Remove any built-up debris from the DR PRO-XL CHIPPER-SHREDDER Hopper Inlet(s) and Discharge Chute.</li> </ul>
<i>The machine has excessive vibration.</i>	<ul style="list-style-type: none"> <li>⇒ Check for a dull or damaged Knife; sharpen or replace the Knife.</li> <li>⇒ The Rotor is out of balance. Check the Rotor Assembly for any missing or broken Hammers or Spacers; replace if necessary.</li> <li>⇒ The Knife may not be seated properly on the Rotor. Loosen the Knife mounting screws, reset the Knife, and tighten the screws. Also, check the Knife to Wear Plate Gap.</li> <li>⇒ If your machine still exhibits excessive vibration, visit our website at <a href="http://www.DRpower.com">www.DRpower.com</a>.</li> </ul>
<i>When chipping, the log seems to vibrate excessively and "hammers" my hands.</i>	<ul style="list-style-type: none"> <li>⇒ The Knife is dull; sharpen or replace it.</li> <li>⇒ The gap between the Knife and Wear Plate is too great; adjust the Gap.</li> </ul>
<i>Chipper Knife is hitting the Wear Plate.</i>	<ul style="list-style-type: none"> <li>⇒ The gap between the Knife and the Wear Plate is set incorrectly; adjust the Knife to Wear Plate Gap.</li> </ul>
<i>The machine's wheels track left, or right while being towed.</i>	<ul style="list-style-type: none"> <li>⇒ Check the tire pressure and set to the recommended pressure stamped on the side of the tire.</li> </ul>

## Chapter 6: Parts Lists and Schematic Diagrams

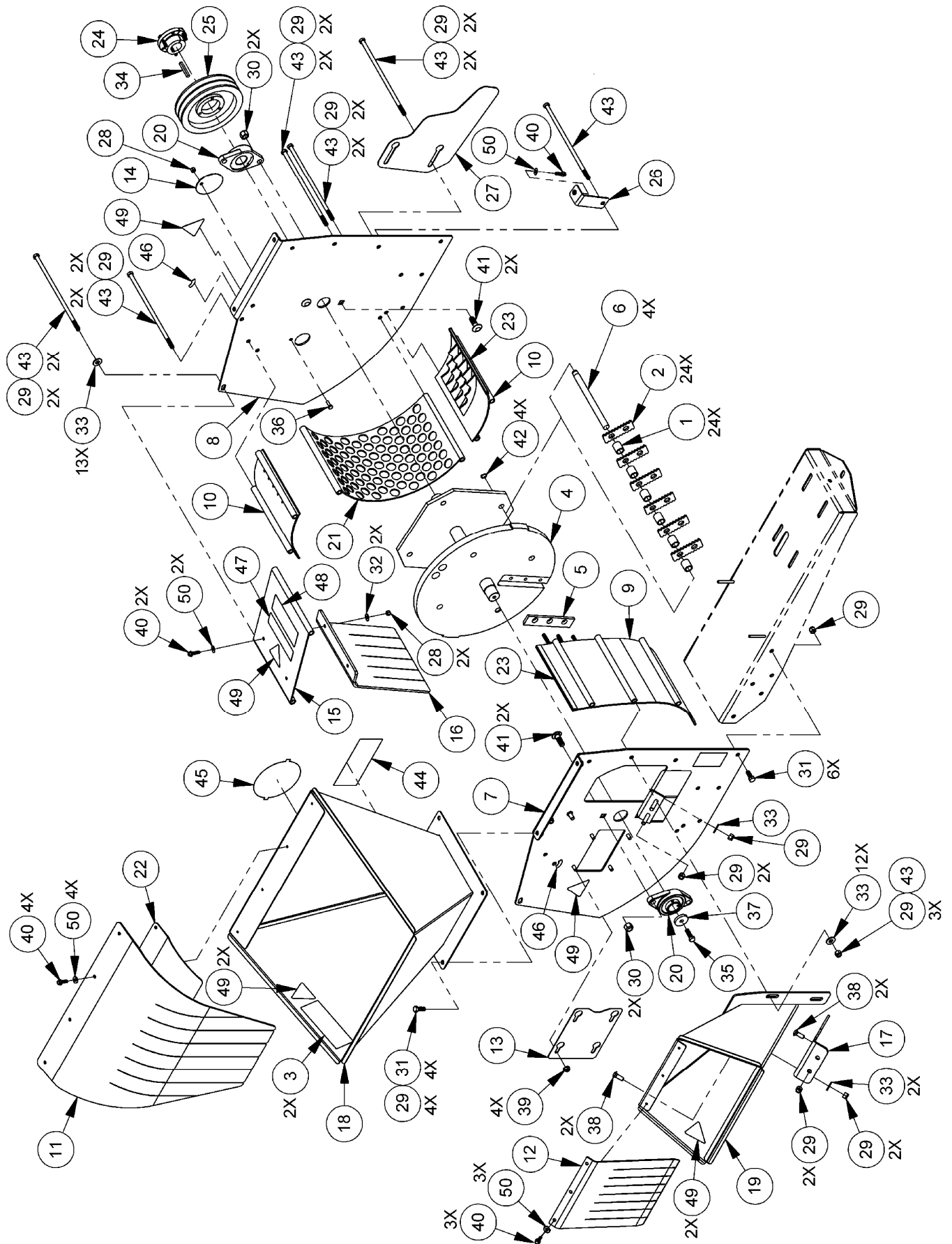
---

### Parts List – Shredder Assembly

*Note: Part numbers listed are available through DR Power Equipment.*

<u>Ref#</u>	<u>Part#</u>	<u>Description</u>	<u>Ref#</u>	<u>Part#</u>	<u>Description</u>
1	10000041629	Spacer, Hammer	26	10000041724	Bracket, Belt Guard, Sideplate Mount
2	10000041665	Hammer, Serrated	27	A0000258771	Guard, Belt Rear
3	A0000222999	Label, Operating	28	110731	Nut, Nylon Lock, 1/4-20
4	10000041619	Rotor	29	110751	Nut, Nylon Lock, 3/8-16
5	380491	Knife Kit	30	110721	Nut, Nylon Lock, 1/2-13
6	10000041701	Shaft, Hammer, 6 Stack	31	111521	Bolt, HCS, 3/8-16 X 1", GR5, ZP
7	A0000267473	Sideplate, Chipper Side W/ Labels	32	112381	Washer, Flat, 1/4" USS
8	A0000267438	Sideplate, Drive Side W/ Labels	33	121701	Washer, Flat, 3/8" SAE
9	A0000176950	Housing, Upper Scroll	34	164521	Key, Square, 1/4" X 2"
10	10000041648	Housing, Fin Scroll	35	165131	Bolt, Hex, 3/8-24 X 1 1/4", GR8 W/Patch
11	10000041659	Guard, Hopper, Shredder	36	157301	Bolt, HCS, 1/4-20 X 3/4", GR5, ZP
12	10000041646	Guard, Chute, Chipper	37	228871	Washer, 385"ID 1.5" OD, .25"L
13	A0000176945	Plate, Knife Access	38	321041	Bolt, Carriage, 3/8-16 X 1", GR5 ZP
14	A0000176941	Plate, Hammer Access	39	333321	Nut, Nylon Lock, Flanged, 5/16-18
15	A0000267472	Housing, Top Plate W/ Labels	40	157301	Bolt, HCS, 1/4-20 X 3/4", GR5, ZP
16	10000041647	Guard, Discharge	41	386541	Bolt, Carr, 1/2-13 X 1-1/2", GR5 ZP
17	10000041678	Plate, Wear	42	10000041700	Ring, Retaining, 9/16"
18	A0000267474	Hopper, Shredder W/ Labels	43	A0000075292	Bolt, HHCS, 3/8-16 X 11", GR5, ZP
19	A0000267475	Chute, Chipper W/ Labels	44	A0000175161	Label, Pro XI501
20	10000043547	Bearing, Flange, 1-1/4" Shaft	45	A0000181455	Label, DR Logo, 5.5", Die Cut
21	10000041711	Screen	46	386691	Label, Screen Bolt
22	A0000024455	Support, Guard, Hopper	47	10000042639	Label, Warning
23	A0000058030	Trim-U Channel, .125" Vinyl MC	48	10000042667	Label, Danger
24	10000041973	Bushing, QD, 1.25", SDS	49	10000042683	Label, Warning, Rotating Blade
25	10000041916	Pulley, Vbelt, 2 Groove, 7.15" Od, QD Bushing	50	143391	Washer, Flat, 1/4", SAE, ZP

**Schematic –SHREDDER ASSEMBLY**

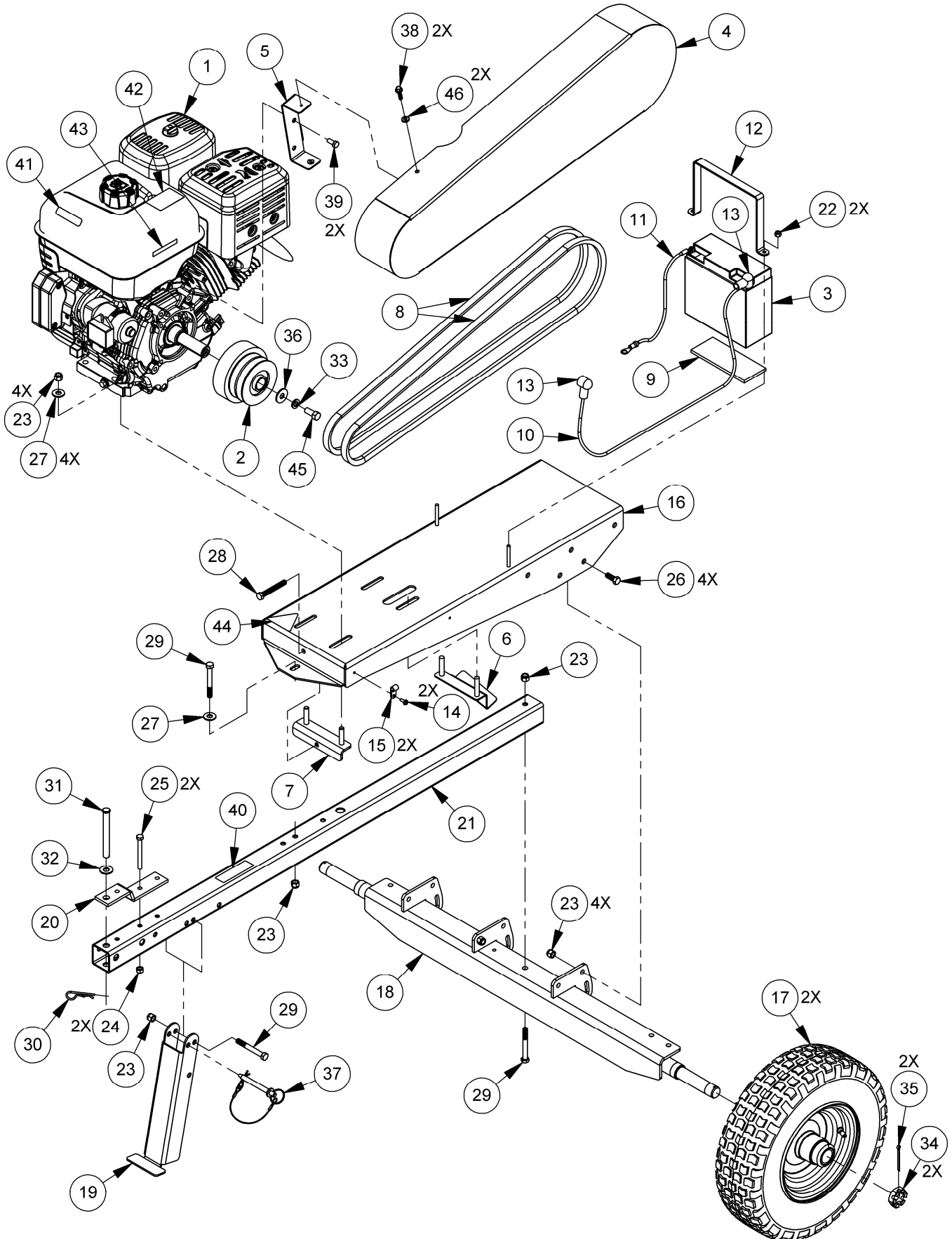


## Parts List –Frame and Drive Assembly

**Note:** Part numbers listed are available through DR Power Equipment.

Ref#	Part#	Description	Ref#	Part#	Description
1	A0000267435	Engine, B&S 21.0 GTQ (13.5 GHP), E/S w/Labels	24	110761	Nut, Nylon Lock, 5/16-18
2	10000043555	Clutch, Centrifugal, 1" Bore, 1800 Rpm, 2v	25	111411	Bolt, HCS, 5/16-18 X 3", GR5, ZP
3	104831	Battery, 17Ah, 12V	26	111521	Bolt, HCS, 3/8-16 X 1", GR5 ZP
4	10000041723	Guard, Belt	27	121701	Washer, Flat, 3/8", SAE
5	10000041732	Bracket, Belt Guard, Engine Mount	28	10000037755	Bolt, Hex, 5/16-18 X 2-1/2", TRI FT
6	10000041927	Bracket, Oil Drain	29	129601	Bolt, HCS, 3/8-16 X 3", GR5, ZP
7	10000030715	Bracket, Belt Tensioner	30	160031	Pin, Hitch Clip, 1/2"-9/16"
8	10000042000	Belt, V-B64, Corded, Raw Edge	31	187371	Pin, Clevis, 1/2" X 4.5" L, ZP
9	286971	Pad, Battery, 2.5" X 6.125", Stg	32	189671	Washer, Rubber, 1/2" ID 1" OD
10	A0000069779	Wire, Positive, 30"	33	151321	Washer, Split, 7/16", GR8
11	A0000069783	Wire, Ground, 12"	34	253101	Nut, Castle, 1-14
12	124511	Clamp, Battery	35	253111	Pin, Cotter, 5/32" X 2", ZP
13	294871	Boot, Rubber, Red	36	191301	Washer, Flat, .469" ID X 1.62" OD .25" L, GR5
14	111701	Screw, 10-32 X 1/2", Type F	37	323971	Pin, Hitch, 3/8" X 3", W/Cotter Pin
15	373401	Clamp, Cable, 3/8", Nylon Black	38	157301	Bolt, HCS, 1/4-20 X 3/4", GR5, ZP
16	A0000268958	Frame, Base w/Labels	39	G048614	Screw, HHC, 5/16-24 X 3/4", GR
17	252971	Wheel and Tire Assembly	40	250441	Label, Warning, Pinch Point, 3.5" X 1"
18	10000041386	Frame, Axle	41	137581	Label, Check Oil, 2.75" X .63"
19	10000033739	Leg, Support, Road Tow	42	188871	Label, Hot Surface, R/C
20	10000033766	Plate, Hitch, Bent	43	10000036023	Decal, Prop 65 Short Form
21	A0000267433	Frame, Tow Bar w/ Labels	44	10000043333	Label, Warning, Tow Max 10mph
22	110731	Nut, Nylon Lock, 1/4-20	45	396111	Bolt, HCS, 7/16-20 X 1-3/4", GR8, ZP
23	110751	Nut, Nylon Lock, 3/8-16	46	143391	Washer, Flat, 1/4", SAE, ZP

**Schematic – Frame and Drive assembly**



**Notes:**

# DR<sup>®</sup> PRO-XL CHIPPER-SHREDDER



## 2-Year Limited Warranty Terms and Conditions

The DR<sup>®</sup> PRO-XL CHIPPER-SHREDDER is warranted for two (2) years against defects in materials or workmanship when put to ordinary and normal consumer use; ninety (90) days for any other use.

For the purposes of all the above warranties, “ordinary and normal consumer use” refers to non-commercial residential use and does not include misuse, accidents or damage due to inadequate maintenance.

DR Power Equipment certifies that the DR<sup>®</sup> PRO-XL CHIPPER-SHREDDER is fit for ordinary purposes for which a product of this type is used. DR Power Equipment however, limits the implied warranties of merchantability and fitness in duration to a period of two (2) years in consumer use, ninety (90) days for any other use.

The 2-Year Limited Warranty on the DR<sup>®</sup> PRO-XL CHIPPER-SHREDDER starts on the date the machine ships from our factory. The 2-Year Limited Warranty is applicable only to the original owner.

The warranty holder is responsible for the performance of the required maintenance as defined by the manufacturer's owner's manuals. The warranty holder is responsible for replacement of normally wearing parts such as the Drive Belt, Air Filter, Spark Plug, Clutch, Chipper Knife, Wear Plate, Shredder Hammers and Highway Wheels. Accessories to the machine are not covered by this warranty.

During the warranty period, the warranty holder is responsible for the machine transportation charges, if required. During the warranty period, warranty parts will be shipped by standard method at no charge to the warranty holder. Expedited shipping of warranty parts is the responsibility of the warranty holder.

SOME STATES DO NOT ALLOW LIMITATIONS ON THE LENGTH OF IMPLIED WARRANTIES, SO THE ABOVE LIMITATIONS MAY NOT APPLY TO YOU.

DR Power Equipment shall not be liable under any circumstances for any **incidental or consequential damages or expenses** of any kind, including, but not limited to, cost of equipment rentals, loss of profit, or cost of hiring services to perform tasks normally performed by the DR<sup>®</sup> PRO-XL CHIPPER-SHREDDER.

SOME STATES DO NOT ALLOW THE EXCLUSION OR LIMITATION OF INCIDENTAL OR CONSEQUENTIAL DAMAGES, SO THE ABOVE LIMITATIONS MAY NOT APPLY TO YOU.

THIS WARRANTY GIVES YOU SPECIFIC LEGAL RIGHTS, AND YOU ALSO HAVE OTHER RIGHTS, WHICH VARY FROM STATE TO STATE.

## Daily Checklist for the DR PRO-XL CHIPPER-SHREDDER

To help maintain your DR PRO-XL CHIPPER-SHREDDER for optimum performance, we recommend you follow this checklist each time you use your DR PRO-XL CHIPPER-SHREDDER.

### WARNING

Before performing any maintenance procedure or inspection, stop the Engine, wait five (5) minutes to allow all parts to cool. Disconnect the Spark Plug Wire keeping it from the Spark Plug

- [ ] Check the Engine oil and Fuel Tank levels
- [ ] Check that the Engine is clean and free of debris.
- [ ] Inspect the Hopper(s) for accumulated debris.
- [ ] Check the general condition of the DR PRO-XL CHIPPER-SHREDDER, e.g.; Nuts, Bolts, welds, etc.
- [ ] Check the Belt for wear and/or stretching.
- [ ] Check Tire Pressures and wear.
- [ ] Check the Chipper Knife for tightness, nicks and wear.
- [ ] Check the Wear Plate for tightness and nicks; the edge should be square.
- [ ] Check the Debris Guard for wear and damage.
- [ ] Remove any debris wrapped around the Hammer(s) and Rotor.

### End of Season and Storage

### WARNING

Before performing any maintenance procedure or inspection, stop the Engine, wait five minutes to allow all parts to cool. Disconnect the Spark Plug Wire, keeping it away from the Spark Plug Wire, keeping it away from the Spark Plug.

**NOTE:** Please refer to the Engine Owner's Manual for Engine-specific procedures.

- Change the Engine oil.
- Clean or replace the Air Filter and Fuel Filter (if equipped).
- Check the Chipper Knife, Hammers, and Wear Plate for nicks and wear.
- Remove any debris wrapped around the Hammers or Rotor.
- If your DR PRO-XL CHIPPER-SHREDDER will be idle for more than 30 days, we recommend using a gas stabilizer. This will prevent sediment from gumming up the Carburetor. If there is dirt or moisture in the gas or Tank, remove it by draining the Tank. Completely fill the Tank with fresh, unleaded gas and add the appropriate amount of stabilizer or gasoline additive. Run the Engine for a short time to allow the additive to circulate. Close the Fuel Shut-Off Valve to prevent Carburetor overflow and leakage.
- Clean the exterior of the unit to remove all dirt, grease, and any other foreign material. To prevent rust, touch up painted surfaces that have been scratched or chipped.
- Be sure all nuts, bolts, and screws are securely fastened.
- Inspect moving parts and the Drive Belts for damage and wear; replace if necessary.
- Remove the Spark Plug and pour about 1 ounce of motor oil into the cylinder hole. Reinstall the Plug and engage the Electric Starter for a few seconds. This will coat the pistons and seat the valves to prevent moisture buildup.
- If possible, store the DR PRO-XL CHIPPER-SHREDDER in a dry, protected place. If it is necessary to store the machine outside, after the DR PRO-XL CHIPPER-SHREDDER has cooled, cover the machine with a suitable protective cover that does not retain moisture. Do not use plastic as this material cannot breathe; it also allows condensation to form, which will cause your machine to rust.
- Remove the Battery or store your DR PRO-XL CHIPPER-SHREDDER in a dry environment where the temperature is between  $-10^{\circ}\text{F}$  ( $-23^{\circ}\text{C}$ ) and  $+85^{\circ}\text{F}$  ( $+23^{\circ}\text{C}$ ). Make sure the storage temperatures will never be outside these limits.



800 HINESBURG ROAD, SOUTH BURLINGTON VERMONT 05403