

DR[®] RANGER CHIPPER

SAFETY & OPERATING INSTRUCTIONS

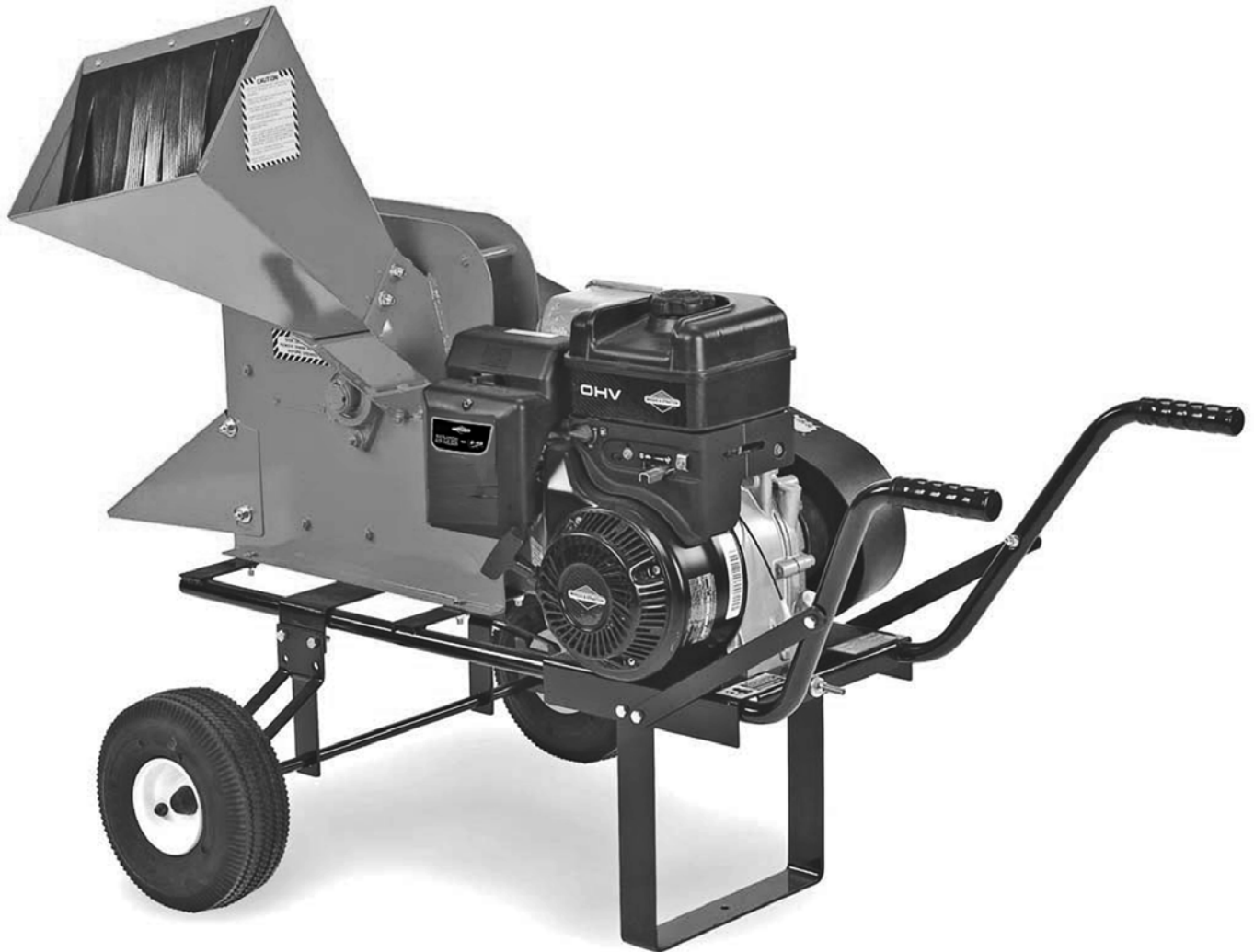

! WARNING!
**READ AND UNDERSTAND THIS MANUAL AND ALL INSTRUCTIONS
BEFORE OPERATING THIS CHIPPER.**

THANK YOU!

Congratulations on your purchase of a new DR RANGER CHIPPER!

We have done our utmost to ensure that your DR RANGER CHIPPER will be one of the most trouble-free and satisfying pieces of equipment you have ever owned. Please let us know of any questions you may have. We want to answer or correct them as quickly as possible. When you do call, please have your serial number and/or order number handy. **For technical assistance, please call Toll-Free 1-800-DR-OWNER (376-9637) and one of our Technical Support Representatives will be happy to help you.** We also hope to hear from you on how much you like your new helper.

In addition, please tell your friends about your new DR RANGER CHIPPER! Having owners spread the word about our products and our way of doing business is the best advertising we can have, and the best way to help us provide even better service in the years to come.

Thanks once again!



for all of us at
COUNTRY HOME PRODUCTS, INC.®

SALES MANAGER

COPYRIGHT

©2006 Country Home Products, Inc. All rights reserved.



DR® Power Equipment
A division of Country Home Products®
127 Meigs Road
Vergennes, VT 05491

Toll-Free phone: 1-800-DR-OWNER (376-9637)

Fax: 1-802-877-1213

Web site: www.dr-owner.com

Table of Contents

CHAPTER 1	1
INTRODUCING THE DR RANGER CHIPPER	1
Conventions used in this manual	1
CHAPTER 2	3
GENERAL SAFETY RULES.....	3
Labels	3
Protecting Yourself and Those Around You	6
Safety for Children and Pets	7
Safety with Gasoline - Powered Engines	7
General Safety	8
A Note to All Users	9
Additional Information and Potential Changes	9
CHAPTER 3	11
SETTING UP YOUR DR RANGER CHIPPER	11
Unpacking	11
Attaching the Chipper Hopper	13
Check the Tire Pressure	13
Adding the Engine Oil and Gasoline.....	14
CHAPTER 4	17
OPERATING YOUR DR RANGER CHIPPER.....	17
Before Starting the Engine.....	17
Operation Notes	18
Processing Limbs and Branches	19
Starting and Stopping the Engine	20
Using the Chipper Hopper	21
To Free a Jammed Flywheel.....	22
CHAPTER 5	25
MAINTAINING THE DR RANGER CHIPPER.....	25
Regular Maintenance Check List.....	25
Grease Fittings.....	26
Removing and Replacing the Engine Oil	27
Adjusting or Removing and Replacing the Drive Belt	28
Removing and Replacing the Chipper Knife	31
Knife Sharpening.....	31
Adjusting the Knife to Wear Plate Gap.....	33
Removing and Replacing the Clutch	34
End of Season and Storage.....	37
CHAPTER 6	39
TROUBLESHOOTING.....	39
Troubleshooting Table.....	39
CHAPTER 7	42
PARTS LISTS, SCHEMATIC DIAGRAMS AND WARRANTY	42
Parts List - DR RANGER CHIPPER.....	42
Schematic - DR RANGER CHIPPER	43
Parts List - Chipper Assembly.....	44
Schematic - Chipper Assembly	45
Notes	46
Warranty	47

INTRODUCING THE DR RANGER CHIPPER

This manual will help you set up and safely operate your new DR RANGER CHIPPER. Careful adherence to the safety and operating instructions in this manual will ensure many years of productive use.

Please let us know of any questions you may have. We want to answer them as quickly as possible. When you do call, please have your serial number and/or order number handy. **For technical assistance, please call Toll-Free 1-800-DR-OWNER (376-9637) and one of our Technical Support Representatives will be happy to help you.**

Conventions used in this manual

WARNING!

THIS INDICATES A HAZARDOUS SITUATION, WHICH, IF NOT AVOIDED, COULD RESULT IN DEATH OR SERIOUS INJURY.

CAUTION!

THIS INDICATES A HAZARDOUS SITUATION, WHICH, IF NOT AVOIDED, COULD RESULT IN MINOR OR MODERATE INJURY.

NOTICE!

THIS INFORMATION IS IMPORTANT IN THE PROPER USE OF YOUR MACHINE. FAILURE TO FOLLOW THIS INSTRUCTION COULD RESULT IN DAMAGE TO YOUR MACHINE OR PROPERTY.

Tip: This is a helpful hint to guide you in getting the most out of your DR RANGER CHIPPER.

Tools Needed: This indicates you will need a special tool to perform a maintenance function on your Chipper.

NOTE: *This information may be helpful to you.*

If you are ever unsure about an action you are about to take, don't do it. Contact Country Home Products' Toll-Free support at 1-800-DR-OWNER (376-9637) for help or information.

GENERAL SAFETY RULES

WARNING!

- READ THIS *SAFETY & OPERATING INSTRUCTIONS* MANUAL BEFORE YOU USE THE DR RANGER CHIPPER. BECOME FAMILIAR WITH THE OPERATION AND SERVICE RECOMMENDATIONS TO ENSURE THE BEST PERFORMANCE FROM YOUR MACHINE.
- THOROUGHLY INSPECT THE AREA IN WHICH YOU WILL BE WORKING AND REMOVE ALL FOREIGN OBJECTS. LOOK FOR ROPE, WIRE, ETC., AND REMOVE THESE OBJECTS BEFORE CHIPPING. INSERTING THESE OBJECTS INTO THE CHIPPER COULD DAMAGE THE MACHINE AND/OR CAUSE INJURY.
- THIS IS A HIGH-POWERED MACHINE, WITH MOVING PARTS OPERATING WITH HIGH ENERGY AT HIGH SPEEDS. YOU MUST USE PROPER CLOTHING AND SAFETY GEAR WHEN OPERATING THIS MACHINE TO PREVENT OR MINIMIZE THE RISK OF SEVERE INJURY. THIS MACHINE CAN CRUSH, GRIND, CUT, AND SEVER PARTS OF YOUR BODY IF THEY ENTER THE INLET OR DISCHARGE AREA OF YOUR CHIPPER.

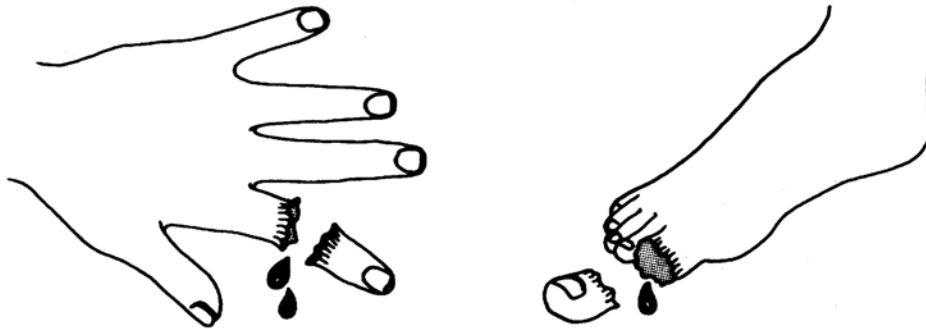

Labels

Your DR RANGER CHIPPER carries prominent labels as reminders for its proper and safe use. Shown below are copies of all the labels that appear on the equipment. Take a moment to study them and make a note of their location on your DR RANGER CHIPPER as you assemble and *before* you operate the unit. Replace damaged or missing safety and information labels immediately.



Make sure to read and observe all Cautions before operating the DR RANGER CHIPPER. (#154701)



ALWAYS turn OFF the Engine, wait five (5) minutes to make certain the Flywheel and all moving parts have come to a complete stop and cool and then disconnect the Spark Plug wire before opening this Access Panel. (#154981)



To avoid injury, keep your hands and feet out of the Inlet and Discharge Chutes. (#227131)



To avoid injury, never remove the protective cover while the Flywheel is turning. (#154691)



To avoid injury, keep your hands and feet out of the Inlet Chute. (#227141)



This label reminds you about the importance of reading and understanding the *Safety & Operating Instructions* Manual and of paying attention to the Safety Warnings. (#227151)



To avoid injury, keep your hands and feet out of the Inlet and Discharge Chutes. (#155941)



ALWAYS turn OFF the Engine, wait five (5) minutes to make certain the Flywheel and all moving parts have come to a complete stop and cool, and then disconnect the Spark Plug wire before servicing the machine. (#227161)

WARNING: Check Oil Before Starting Engine

The Engine ships without oil, always check the Engine oil before starting the DR RANGER CHIPPER. (#127811)

CAUTION
CLUTCH DAMAGE DUE TO ENGINE OVERLOAD CAN BE VERY COSTLY AND MAY NOT BE COVERED UNDER WARRANTY.
BECOME FAMILIAR WITH SUCCESSFUL OPERATING CONDITIONS AND AVOID THOSE THAT CAN OVERLOAD AND DAMAGE THE CLUTCH.
SEE OWNER'S MANUAL FOR ADDITIONAL OPERATING INSTRUCTIONS AND TIPS.

Always use care when loading the DR RANGER CHIPPER. Overloading will damage the Clutch and will not be covered under the Warranty. (#207031)



The DR RANGER CHIPPER is made in the U.S.A. (#227171)

! WARNING!

THIS IS A HIGH-POWERED MACHINE, WITH MOVING PARTS OPERATING WITH HIGH ENERGY AT HIGH SPEEDS. YOU MUST OPERATE THE MACHINE SAFELY. UNSAFE OPERATION CAN CREATE A NUMBER OF HAZARDS FOR YOU, AS WELL AS ANYONE ELSE IN THE NEARBY AREA. ALWAYS TAKE THE FOLLOWING PRECAUTIONS WHEN USING THIS MACHINE:

- ALWAYS WEAR PROTECTIVE GOGGLES OR SAFETY GLASSES WITH SIDE SHIELDS WHILE CHIPPING WOOD TO PROTECT YOUR EYES FROM POSSIBLE THROWN DEBRIS.
- AVOID WEARING LOOSE CLOTHING OR JEWELRY, WHICH CAN CATCH ON MOVING PARTS OR THE MATERIAL FED INTO THE CHIPPER HOPPER.
- WE RECOMMEND WEARING GLOVES WHILE CHIPPING WOOD. BE SURE YOUR GLOVES FIT PROPERLY AND DO NOT HAVE LOOSE CUFFS OR DRAWSTRINGS.
- WEAR SHOES WITH NON-SLIP TREADS WHEN USING YOUR CHIPPER. IF YOU HAVE SAFETY SHOES, WE RECOMMEND WEARING THEM. DO NOT USE THE MACHINE WHILE BAREFOOT OR WEARING OPEN SANDALS.
- WEAR LONG PANTS WHILE OPERATING THE DR RANGER CHIPPER.
- USE EAR PROTECTORS OR EAR PLUGS RATED FOR AT LEAST 20 DBA TO PROTECT YOUR HEARING.
- NEVER ALLOW PEOPLE WHO ARE UNFAMILIAR WITH THESE INSTRUCTIONS TO USE THE CHIPPER. ALLOW ONLY RESPONSIBLE INDIVIDUALS WHO ARE FAMILIAR WITH THESE RULES OF SAFE OPERATION TO USE YOUR MACHINE.
- NEVER PLACE YOUR HANDS, FEET, OR ANY PART OF YOUR BODY IN THE CHIPPER HOPPER, DISCHARGE OPENING, OR NEAR OR UNDER ANY MOVING PART WHILE THE MACHINE IS RUNNING. KEEP AREA OF DISCHARGE CLEAR OF PEOPLE, ANIMALS, BUILDINGS, GLASS, OR ANYTHING ELSE THAT WILL OBSTRUCT CLEAR DISCHARGE, CAUSE INJURY, OR DAMAGE. WIND CAN ALSO CHANGE DISCHARGE DIRECTION, SO BE AWARE. IF IT BECOMES NECESSARY TO PUSH MATERIAL INTO THE CHIPPER HOPPER, USE A SMALL DIAMETER STICK, NOT WITH YOUR HANDS.
- KEEP BYSTANDERS AWAY FROM YOUR WORK AREA AT ALL TIMES. WOOD CHIPS EXIT THE CHIPPER AT GREAT SPEEDS. TO BE SAFE, DO NOT OPERATE THE MACHINE NEAR SMALL CHILDREN OR PETS, AND NEVER ALLOW CHILDREN TO OPERATE THE CHIPPER. STOP THE ENGINE WHEN ANOTHER PERSON OR PET APPROACHES.
- NEVER USE THE MACHINE WITH THE CHIPPER HOPPER OR DISCHARGE CHUTE REMOVED.
- DO NOT OPERATE THE ENGINE WITH THE AIR CLEANER OR COVER OVER THE CARBURETOR AIR INTAKE REMOVED, EXCEPT FOR ADJUSTMENT. REMOVAL OF SUCH PARTS COULD CREATE A FIRE HAZARD. DO NOT USE FLAMMABLE SOLUTIONS TO CLEAN AIR FILTER.
- ALWAYS OPERATE THE MACHINE FROM THE OPERATOR ZONE (SEE *FIGURE 4* ON PAGE 18). NEVER PASS OR STAND ON THE DISCHARGE SIDE OF THE MACHINE WHEN THE ENGINE IS RUNNING OR THE FLYWHEEL IS TURNING.
- NEVER TRY TO PICK UP, MOVE, OR TRANSPORT THE MACHINE WHILE THE ENGINE IS RUNNING OR THE FLYWHEEL IS TURNING.
- THE MUFFLER AND ENGINE BECOME VERY HOT AND CAN CAUSE A SEVERE BURN; DO NOT TOUCH.
- CLEAR THE AREA OF OBJECTS SUCH AS WIRE AND ROPE ETC. INSERTING THESE OBJECTS INTO THE CHIPPER HOPPER COULD DAMAGE THE FLYWHEEL AND/OR CAUSE INJURY.
- NEVER, UNDER ANY CONDITIONS, REMOVE, BEND, CUT, FIT, WELD, OR OTHERWISE ALTER STANDARD PARTS ON THE DR RANGER CHIPPER. THIS INCLUDES ALL SHIELDS AND GUARDS. MODIFICATIONS TO YOUR MACHINE COULD CAUSE PERSONAL INJURIES AND PROPERTY DAMAGE AND WILL VOID YOUR WARRANTY.

Safety for Children and Pets

WARNING!

TRAGIC ACCIDENTS CAN OCCUR IF THE OPERATOR IS NOT ALERT TO THE PRESENCE OF CHILDREN AND PETS. CHILDREN ARE OFTEN ATTRACTED TO THE MACHINE AND THE CHIPPING ACTIVITY. **NEVER** ASSUME THAT CHILDREN WILL REMAIN WHERE YOU LAST SAW THEM. ALWAYS FOLLOW THESE PRECAUTIONS:

- KEEP CHILDREN AND PETS OUT OF THE WORKING AREA AND UNDER THE WATCHFUL CARE OF A RESPONSIBLE ADULT.
 - BE ALERT AND TURN THE MACHINE OFF IF CHILDREN OR PETS ENTER THE WORK AREA.
 - NEVER ALLOW CHILDREN TO OPERATE THE CHIPPER.
-

Safety with Gasoline - Powered Engines

WARNING!

GASOLINE IS A HIGHLY FLAMMABLE LIQUID. GASOLINE ALSO GIVES OFF FLAMMABLE VAPOR THAT CAN BE EASILY IGNITED AND CAUSE A FIRE OR EXPLOSION. NEVER OVERLOOK THE HAZARDS OF GASOLINE. ALWAYS FOLLOW THESE PRECAUTIONS:

- NEVER RUN THE ENGINE IN AN ENCLOSED AREA OR WITHOUT PROPER VENTILATION AS THE EXHAUST FROM THE ENGINE CONTAINS CARBON MONOXIDE, WHICH IS AN ODORLESS, TASTELESS, AND DEADLY POISONOUS GAS.
 - STORE ALL FUEL AND OIL IN CONTAINERS SPECIFICALLY DESIGNED AND APPROVED FOR THIS PURPOSE AND KEEP AWAY FROM HEAT AND OPEN FLAME, AND OUT OF THE REACH OF CHILDREN.
 - FILL THE GASOLINE TANK OUTDOORS WITH THE ENGINE OFF AND ALLOW THE ENGINE TO COOL COMPLETELY. DO NOT HANDLE GASOLINE IF YOU OR ANYONE NEARBY IS SMOKING, OR IF YOU ARE NEAR ANYTHING THAT COULD CAUSE IT TO IGNITE OR EXPLODE. REINSTALL THE FUEL TANK AND FUEL CONTAINER CAPS SECURELY.
 - IF YOU SPILL GASOLINE, DO NOT ATTEMPT TO START THE ENGINE. MOVE THE MACHINE AWAY FROM THE AREA OF THE SPILL AND AVOID CREATING ANY SOURCE OF IGNITION UNTIL THE GAS VAPORS HAVE DISSIPATED. WIPE UP ANY SPILLED FUEL TO PREVENT A FIRE HAZARD AND PROPERLY DISPOSE OF THE WASTE.
 - ALLOW THE ENGINE TO COOL COMPLETELY BEFORE STORING IN ANY ENCLOSURE. NEVER STORE THE MACHINE WITH GAS IN THE TANK OR A FUEL CONTAINER, NEAR AN OPEN FLAME OR SPARK SUCH AS A WATER HEATER, SPACE HEATER, CLOTHES DRYER OR FURNACE.
 - NEVER MAKE ADJUSTMENTS OR REPAIRS WITH THE ENGINE RUNNING OR FLYWHEEL TURNING. STOP THE ENGINE, WAIT FIVE (5) MINUTES TO MAKE CERTAIN THE FLYWHEEL AND ALL MOVING PARTS HAVE COME TO A COMPLETE STOP AND COOL. DISCONNECT THE SPARK PLUG WIRE, KEEPING IT AWAY FROM THE SPARK PLUG TO PREVENT ACCIDENTAL STARTING.
 - NEVER TAMPER WITH THE ENGINE'S GOVERNOR SETTING. THE GOVERNOR CONTROLS THE MAXIMUM SAFE OPERATING SPEED AND PROTECTS THE ENGINE. OVER-SPEEDING THE ENGINE IS DANGEROUS AND WILL CAUSE DAMAGE TO THE ENGINE AND TO THE OTHER MOVING PARTS OF THE MACHINE. IF REQUIRED, SEE YOUR AUTHORIZED ENGINE DEALER FOR ENGINE GOVERNOR ADJUSTMENTS.
 - TO REDUCE FIRE HAZARD, KEEP THE ENGINE AND MUFFLER FREE OF DEBRIS BUILD-UP.
-

General Safety

WARNING!

YOU MUST OPERATE THE CHIPPER SAFELY TO PREVENT OR MINIMIZE THE RISK OF DEATH OR SERIOUS INJURY. UNSAFE OPERATION CAN CREATE A NUMBER OF HAZARDS FOR YOU. ALWAYS TAKE THE FOLLOWING PRECAUTIONS WHEN OPERATING THIS CHIPPER:

- KEEP IN MIND THAT THE OPERATOR OR USER IS RESPONSIBLE FOR ACCIDENTS OR HAZARDS OCCURRING TO OTHER PEOPLE, THEIR PROPERTY, AND THEMSELVES.
- YOUR DR RANGER CHIPPER IS A POWERFUL TOOL, NOT A PLAYTHING. EXERCISE EXTREME CAUTION AT ALL TIMES. THE DESIGN OF YOUR MACHINE IS TO CHIP WOOD. DO NOT USE IT FOR ANY OTHER PURPOSE.
- KNOW HOW TO STOP THE CHIPPER QUICKLY; SEE PAGE 20.
- OPERATE THIS MACHINE ON A LEVEL SURFACE ONLY. NEVER OPERATE YOUR UNIT ON A SLIPPERY, WET, MUDDY, OR ICY SURFACE. EXERCISE CAUTION TO AVOID SLIPPING OR FALLING.
- KEEP YOUR FACE AND BODY BACK FROM THE CHIPPER HOPPER TO AVOID ACCIDENTAL BOUNCE BACK OF ANY MATERIAL.
- WHEN FEEDING MATERIAL INTO THE CHIPPER HOPPER, BE EXTREMELY CAREFUL THAT PIECES OF METAL, ROCKS, OR OTHER FOREIGN OBJECTS ARE NOT INCLUDED. PERSONAL INJURY OR DAMAGE TO THE MACHINE COULD RESULT.
- NEVER ALLOW AN ACCUMULATION OF PROCESSED MATERIAL TO BUILD UP IN THE DISCHARGE AREA AS THIS WILL PREVENT PROPER DISCHARGE AND CAN RESULT IN KICKBACK FROM THE CHIPPER HOPPER.
- WHENEVER YOU LEAVE THE OPERATING POSITION OR IF YOU HAVE TO REMOVE PROCESSED MATERIAL, LEAVES, OR DEBRIS FROM THE MACHINE, ALWAYS SHUT OFF THE ENGINE AND WAIT FIVE (5) MINUTES TO MAKE CERTAIN THE FLYWHEEL AND ALL MOVING PARTS HAVE COME TO A COMPLETE STOP AND COOL. REMOVE THE KEY, IF SO EQUIPPED, AND DISCONNECT THE SPARK PLUG WIRE AND KEEP THE WIRE AWAY FROM THE SPARK PLUG TO PREVENT ACCIDENTAL STARTING BEFORE ADJUSTING THE MACHINE.
- ALWAYS STOP THE ENGINE WHEN MOVING THE DR RANGER CHIPPER.
- KEEP COMBUSTIBLE SUBSTANCES AWAY FROM THE ENGINE WHEN IT IS HOT.
- NEVER COVER THE MACHINE WHILE THE MUFFLER IS STILL HOT.
- SEE MANUFACTURE'S INSTRUCTIONS FOR PROPER OPERATION AND INSTALLATION OF ACCESSORIES. ONLY USE ACCESSORIES APPROVED BY COUNTRY HOME PRODUCTS, INC.
- IF THE CUTTING MECHANISM STRIKES A FOREIGN OBJECT OR IF YOUR MACHINE SHOULD START MAKING AN UNUSUAL NOISE OR VIBRATION, STOP THE ENGINE AND WAIT FIVE (5) MINUTES FOR ALL MOVING PARTS TO COME TO A COMPLETE STOP AND COOL. VIBRATION IS GENERALLY A WARNING OF TROUBLE. DISCONNECT THE SPARK PLUG WIRE AND INSPECT FOR CLOGGING OR DAMAGE. CLEAN AND REPAIR AND/OR REPLACE DAMAGED PARTS.
- NEVER TAMPER WITH SAFETY DEVICES. CHECK THEIR PROPER OPERATION REGULARLY.

! WARNING!

- NEVER OVERLOAD OR ATTEMPT TO CHIP MATERIAL BEYOND THE MANUFACTURER'S RECOMMENDATION; SEE PAGE 21. PERSONAL INJURY OR DAMAGE TO THE MACHINE COULD RESULT.
 - WHILE USING THE DR RANGER CHIPPER, DO NOT HURRY OR TAKE THINGS FOR GRANTED. WHEN IN DOUBT ABOUT THE EQUIPMENT OR YOUR SURROUNDINGS, STOP THE MACHINE AND TAKE THE TIME TO LOOK THINGS OVER.
 - NEVER OPERATE THE MACHINE WHEN UNDER THE INFLUENCE OF ALCOHOL, DRUGS, OR MEDICATION.
 - USE THE MACHINE ONLY IN DAYLIGHT.
 - KEEP ALL NUTS AND BOLTS TIGHT AND KEEP THE EQUIPMENT IN GOOD OPERATING CONDITION.
 - NO LIST OF WARNINGS AND CAUTIONS CAN BE ALL-INCLUSIVE. IF SITUATIONS OCCUR THAT ARE NOT COVERED BY THIS MANUAL, THE OPERATOR MUST APPLY COMMON SENSE AND OPERATE THIS CHIPPER IN A SAFE MANNER. CALL 1-800-DR-OWNER (376-9637) FOR ASSISTANCE.
-

A Note to All Users

Under California law, and the laws of some other states, you are not permitted to operate an internal combustion engine using hydrocarbon fuels without an engine spark arrester. This also applies to operation on US Forest Lands. All DR RANGER CHIPPERS shipped to California and Washington State are provided with spark arresters. Failure of the owner/operator to maintain this equipment in compliance with state regulations is a misdemeanor under California law and may be in violation of other state and/or federal regulations. Contact your local fire marshal or forest service for specific information in your area.

Additional Information and Potential Changes

Country Home Products, Inc. reserves the right to discontinue, change, and improve its products at any time without notice or obligation to the purchaser. The descriptions and specifications contained in this manual were in effect at printing. Equipment described within this manual may be optional. Some illustrations may not be applicable to your machine.

SETTING UP YOUR DR RANGER CHIPPER

This chapter outlines unpacking and a few simple steps you will need to follow to set up your new machine before you use it. **If you have any questions at all, please feel free to contact our Customer Service Representatives at our Toll-Free number: 1-800-DR-OWNER (376-9637).**

Unpacking

NOTE: *We recommend two people for unpacking as the unit weighs 207 pounds.*

Tools and Supplies Needed:

- Gloves
- Metal Shears (Side Cutters)
- Eye Protection
- Pry Bar
- Hammer

Parts Supplied on Skid:

- DR RANGER CHIPPER
- Parts Box containing:
 - Chipper Hopper
 - Safety Glasses
 - *Safety & Operation Instructions* Manual
 - Engine Owner's Manual
 - Knife Gauge
 - Plastic Bag containing miscellaneous mounting hardware:
 - (4) 5/16" - 18 x 3/4" Carriage Bolt
 - (4) 5/16" - 18 Nylon Lock Nut
 - (4) 5/16" Flat Washer

! WARNING!

- WEAR EYE PROTECTION WHEN CUTTING THE BANDING. THE BANDING MAY HAVE A LOT OF TENSION ON IT AND MAY SNAP AND CUT YOU. ALWAYS STAND TO ONE SIDE WHEN CUTTING THE BAND.
 - STABILIZE THE SHIPPING CONTAINER ON CLEAN FLAT TERRAIN BEFORE ATTEMPTING TO UNPACK AND ASSEMBLE THE MACHINE.
-

1. Pry off the Crate and cut any Bands holding the machine to the Pallet.

Be careful when cutting the Banding.

2. Remove the Parts Box, containing the Chipper Hopper, assembly hardware, manuals etc. from the Shipping Container.
3. With the help of another person, carefully lift the machine from the Shipping Pallet, resting it on its Wheels and Support Leg.
4. Compare the contents of the Shipping Carton and the Parts Box with the Parts Supplied List on the previous page. **If any of the parts are missing, contact 1-800-DR-OWNER (376-9637).** You will need packaging to return the machine, do not discard your Packaging Material until you are fully satisfied with your new DR RANGER CHIPPER.

Attaching the Chipper Hopper

Tool Needed:

- (2) 1/2" Wrench or Socket

Tip: Insert a towel or large rag into the opening to keep the Bolts from falling into the Chipper.

1. Attach the Chipper Hopper to the machine using four (4) 5/16"-18 x 3/4" Carriage Bolts, four (4) 5/16" Flat Washers and four (4) 5/16"-18 Nylon Lock Nuts.

NOTE: Be sure to insert the Bolts from the inside of the Chipper Hopper so that the threads are sticking out (Figure 1).

2. Install a Flat Washer, then a Lock Nut on each bolt. Initially install the Bolts and Nuts finger tight and then tighten the Nuts one (1) turn using two (2) 1/2" wrenches (Figure 1). Check to see that the Hopper is centered on the Inlet Chute and then tighten the Nuts securely.
3. If you used a towel or rag in the Chipper opening, remove it now.

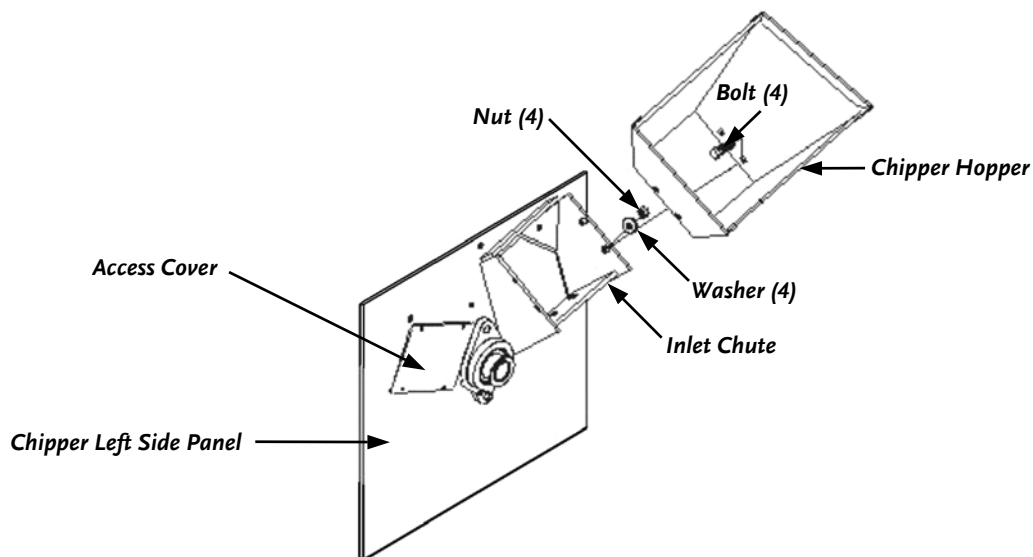

Figure 1

! NOTICE!

BE SURE TO FILL THE ENGINE WITH OIL AND GAS BEFORE USE. IF YOU START THE ENGINE WITHOUT OIL IN THE CRANKCASE, THE ENGINE WILL BE DAMAGED BEYOND REPAIR AND WILL NOT BE COVERED UNDER THE WARRANTY. SEE THE NEXT PAGE FOR OIL AND FUEL FILL.

Check the Tire Pressure

There should be 30 psi in each tire.

Adding the Engine Oil and Gasoline

NOTICE!

- YOU MUST ADD OIL BEFORE STARTING THE ENGINE. THIS MACHINE SHIPPED WITHOUT OIL. TRACES OF OIL MAY BE IN THE RESERVOIR FROM FACTORY TESTING, BUT YOU MUST ADD OIL BEFORE STARTING THE ENGINE.
- TO GET AN ACCURATE READING WHEN CHECKING THE OIL LEVEL, THE MACHINE SHOULD BE ON A LEVEL SURFACE.

Capacities	
Briggs & Stratton 13.5 Ft.-Lbs. Intek Engine	SAE 30 HD - 28 oz. (.83L)
Gasoline Tank	Unleaded gasoline, 1 US gal. (3.8 L)

Tip: To avoid confusion, we recommend leaving the caps on the Fuel and Engine oil fills and only removing one cap each time when you are ready to pour gasoline or oil into the correct fill.

NOTE: Use SAE 30 high detergent oil classified "For Service SF, SG, SH, SJ" or higher. Do not use special additives. Other types of oil could cause problems operating your machine. Please refer to your Engine Owner's Manual for detailed oil information.

1. Place the machine on a level surface and initially add 1/2 of the SAE 30 high detergent oil recommended by the Engine Manufacturer and wait one minute for the oil to settle (**Figure 2** on page 15).
2. Add oil slowly and fill to the point of just before overflowing, there is no Dip Stick (**Figure 2** on page 15).

WARNING!

FILL GAS TANK OUTDOORS OR IN A WELL-VENTILATED AREA, AWAY FROM SPARKS, OPEN FLAMES, PILOT LIGHTS, HEAT, AND OTHER IGNITION SOURCES.

3. Fill the Gas Tank with fresh, unleaded gas (with a minimum of 85 Octane), to approximately 1" to 1-1/2" below the top of the fill neck to allow for fuel expansion. Be careful not to overfill and reinstall the cap before starting the Engine. See your Engine Owner's Manual for more information.

NOTE: To refill the Gas Tank, turn the Engine OFF and let the Engine cool at least two (2) minutes before removing the Gas Fill Cap.



Figure 2

OPERATING YOUR DR RANGER CHIPPER

This chapter covers the procedures for starting and stopping your new DR RANGER CHIPPER and discusses basic operation features.

! WARNING!

- THE DESIGN OF THIS CHIPPER IS FOR CHIPPING LIMBS OR BRANCHES. NEVER USE THIS MACHINE FOR ANY OTHER PURPOSE AS IT COULD CAUSE SERIOUS INJURY.
- CONTACT WITH INTERNAL ROTATING PARTS WILL CAUSE SERIOUS PERSONAL INJURY. NEVER PUT HANDS, FACE, FEET, OR CLOTHING INTO CHIPPER HOPPER OR DISCHARGE OPENING OR NEAR THE DISCHARGE AREA AT ANY TIME.
- BEFORE PERFORMING ANY MAINTENANCE PROCEDURE OR INSPECTION, STOP THE ENGINE, WAIT FIVE (5) MINUTES TO ALLOW ALL MOVING PARTS TO COME TO A COMPLETE STOP AND COOL. DISCONNECT THE SPARK PLUG WIRE, KEEPING IT AWAY FROM THE SPARK PLUG. USE ONLY A WOODEN STICK TO CLEAR JAMMED MATERIAL AFTER ALL MOVING PARTS HAVE STOPPED COMPLETELY.

Before Starting the Engine

1. Check the oil level every time you use the DR RANGER CHIPPER.
2. Check the gas level.
3. Turn the Gas Shut-Off Valve to the OPEN position (**Figure 3**).
4. Check Inlet and Discharge Chutes and remove any debris buildup from the machine.

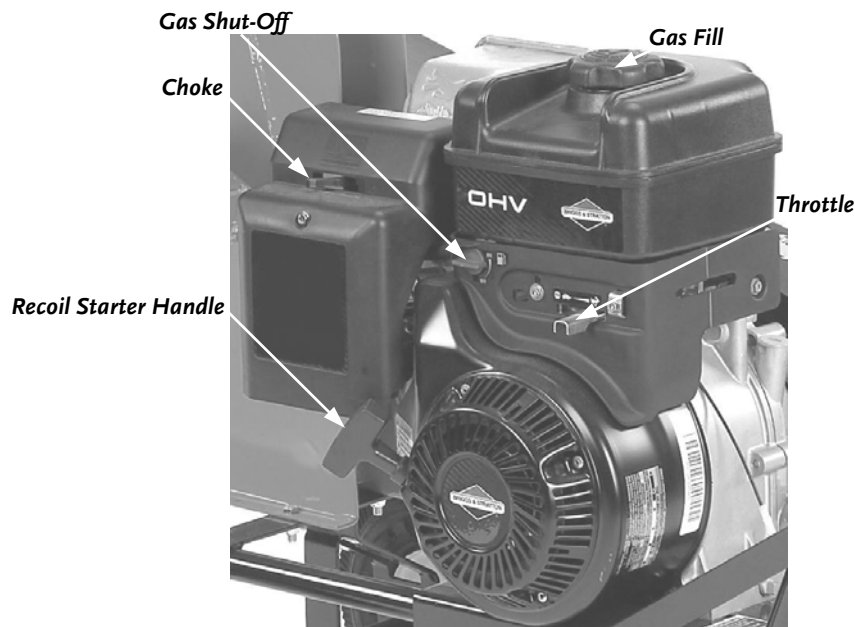

Figure 3

Operation Notes

- Visually check the Chipper Knife for damage each time you use the machine.

NOTE: Check for shaft movement while starting the Engine. If the shaft does not turn, clean out the Chipper as instructed on page 22.

- At Engine start-up, the Engine of your DR RANGER CHIPPER operates under no load until approximately 1200-1400 RPM, at which speed the Centrifugal Clutch engages and begins driving the Rotor Assembly.
- Proper Rotor speed is 2400-RPM +/- 200 RPM.
- When viewed from the Chipper Hopper side (Operator Zone, **Figure 4**), the Flywheel turns in a clockwise direction.
- Always wear protective gloves and safety glasses during operation of the DR RANGER CHIPPER.
- If it becomes necessary to push material into the Chipper Hopper, only use a wood stick, NEVER your hands, or any foreign material such as plastic or metal.
- NEVER assume you know where the Chipper knife is. You do not know where it is. Always keep hands out of the Chipper Hopper.
- Keep area of discharge clear of people, animals, buildings, glass, or anything else that will obstruct clear discharge, cause injury, or damage. Wind can also change discharge direction, so be aware.
- ALWAYS operate the DR RANGER CHIPPER from the Operator Zone (**Figure 4**).
- Keep proper balance and footing while operating the machine.
- When feeding material into the Chipper Hopper, be extremely careful that pieces of metal, rocks, or other foreign objects are not included. Personal injury or damage to the machine could result.
- NEVER operate the machine without the Chipper Hopper and Discharge Chute properly installed.
- If the cutting knife strikes a foreign object or if your machine should start making an unusual noise or vibration, immediately stop the Engine and wait five (5) minutes for all moving parts to come to a complete stop and cool. After the machine has come to a complete stop proceed as follows:
 - Disconnect the Spark Plug wire.
 - Inspect for any damage and repair or replace any damaged parts before restarting and operating the machine.
- ALWAYS stop the Engine when leaving the Operating Zone (**Figure 4**) or when moving the Chipper.

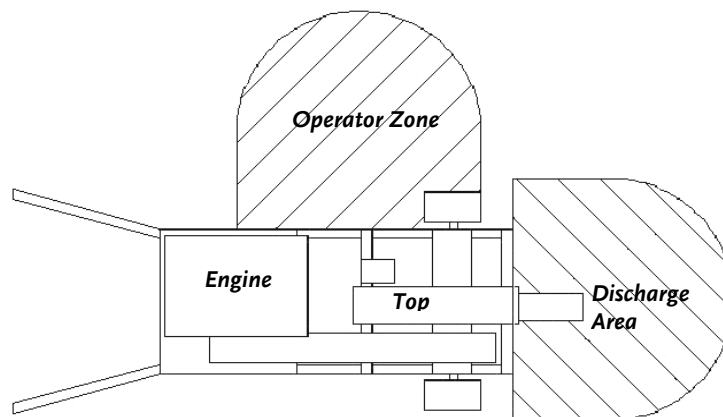

Figure 4

Processing Limbs and Branches

WARNING!

- ALWAYS WEAR PROTECTIVE GOGGLES OR SAFETY GLASSES WITH SIDE SHIELDS WHILE CHIPPING TO PROTECT YOUR EYES FROM POSSIBLE THROWN DEBRIS.
 - AVOID WEARING LOOSE CLOTHING OR JEWELRY, WHICH MIGHT CATCH ON MOVING PARTS OR THE MATERIAL FED INTO THE CHIPPER HOPPER.
 - WE RECOMMEND WEARING GLOVES WHILE CHIPPING. BE SURE YOUR GLOVES FIT PROPERLY AND DO NOT HAVE LOOSE CUFFS OR DRAWSTRINGS.
 - WEAR SHOES WITH NON-SLIP TREADS WHEN USING YOUR CHIPPER. IF YOU HAVE SAFETY SHOES, WE RECOMMEND WEARING THEM. DO NOT USE THE MACHINE WHILE BAREFOOT OR WEARING OPEN SANDALS.
 - WEAR LONG PANTS WHILE OPERATING THE DR RANGER CHIPPER.
 - USE EAR PROTECTORS OR EAR PLUGS RATED FOR AT LEAST 20 DBA TO PROTECT YOUR HEARING.
-

- Your DR RANGER CHIPPER can process dry or green material.
- Green material will process quicker and easier than dry material.
- Soft wood processes easier than hard wood.
- Your operator experience will teach you how different materials chip and how fast you can process different materials.
- It is best to trim off any side twigs from the main branch that you are chipping.
- When chipping branches, sometimes a tail will remain at the end of a branch. To avoid this, rotate the branch while feeding it into the Chipper Hopper.
- Rotating the branch as you feed it into the machine will improve chipping performance.
- Use caution with small diameter green saplings and branches. Chip these grouped or bundled together to provide support for each other.
- Make sure the DR RANGER CHIPPER finishes processing material in the Hopper before shutting the Engine off.

NOTICE!

USE COMMON SENSE WHEN USING THE MACHINE. LEARN TO RECOGNIZE THE CHANGE IN SOUNDS WHEN OVERLOADED. TURN OFF THE ENGINE IMMEDIATELY IF THE MACHINE BECOMES JAMMED TO PREVENT DAMAGE TO THE DRIVE SYSTEM.

Starting and Stopping the Engine

1. When starting a cold Engine; push the Choke Control lever to the right (CHOKE) and the Throttle Control lever to the far right (**Figure 3** on page 17).
2. Grasp the Recoil Starter Handle and **slowly pull until you feel resistance**, then pull the Cord with a **smooth accelerating motion** to start the Engine. One or two pulls usually starts the DR RANGER CHIPPER.
3. After the Engine starts, slowly push the Choke Control lever (**Figure 3** on page 17) to the left (RUN) position. Wait until the Engine runs smoothly before each Choke adjustment. For best Engine performance, we recommend that you operate the Engine with the Throttle in the fast (Rabbit) position (**Figure 3** on page 17).
4. To stop the Engine, move the Throttle to the slow (Turtle) position allowing the Engine to idle, then move the lever to STOP (Stop Sign) position (**Figure 3** on page 17).
5. Turn the Gas Shut-Off Valve to the CLOSED position.

NOTICE!

NEVER STOP THE ENGINE BY MOVING THE CHOKE LEVER TO THE CHOKE POSITION. THIS COULD CAUSE AN ENGINE BACKFIRE RESULTING IN ENGINE DAMAGE.

Using the Chipper Hopper

The design of the Chipper Hopper mounted on the side of the machine is to chip wood only. The revolving Chipper Knife mounted on a Flywheel turns branches fed into the Chipper Hopper into “chips”. The Chipper can chip twigs and branches up to 3-1/2" in diameter. Cut your materials into manageable lengths before feeding them into the Chipper Hopper.

NOTICE!

MAKE SURE TO SECURELY BOLT THE CHIPPER HOPPER TO THE SIDE OF YOUR DR RANGER CHIPPER BEFORE USING THE MACHINE!

- Feed the branch into Chipper Hopper keeping the branch at the same angle as Chipper Hopper.
- As the branch becomes short and is inside the Chipper Hopper, finish processing it by pushing it into the Chipper with the next branch.
- If the branches to be processed are 1" or larger in diameter, you should feed only one (1) branch at a time into the Chipper. You can feed more than one branch at a time into the Chipper if the branches are smaller than 1" in diameter.
- Do not force material into the Chipper. If the machine does not chip well, the Chipper Knife may need to be sharpened or replaced, or the gap between the Knife and the Wear Plate needs adjusting. See page 33.
- Extremely hard knots will not process very well. Push any short stubs that have not self-fed through the Chipper, with the next branch to be chipped.

NOTICE!

NEVER THROW REMAINING STUBS OR KNOTS INTO THE CHIPPER HOPPER; DAMAGE WILL RESULT.

- Cut the material to be chipped into manageable lengths of no more than five or six feet long before chipping them.
- Overloading the Chipper Hopper will cause the rotor speed to decrease. If you hear the Engine RPM decreasing, stop feeding material into the Chipper Hopper until the Engine has returned to full speed.

NOTICE!

IF YOU JAM THE CHIPPER, IMMEDIATELY SHUT OFF THE ENGINE, THE JAM CAN DAMAGE THE MACHINE. THIS DAMAGE CAN BE COSTLY AND MAY NOT BE COVERED UNDER WARRANTY. FOR THIS REASON, IT IS IMPORTANT THAT YOU IMMEDIATELY SHUT OFF THE ENGINE, WAIT FIVE (5) MINUTES TO MAKE CERTAIN ALL PARTS HAVE COME TO A COMPLETE STOP AND COOLED. BEFORE CLEARING THE JAM (SEE NEXT PAGE), DISCONNECT THE SPARK PLUG WIRE, KEEPING IT AWAY FROM THE SPARK PLUG TO PREVENT ACCIDENTAL STARTING.

- NEVER allow processed material to build up within 3" of the Discharge Chute opening. Move the DR RANGER CHIPPER or the pile as needed. Failure to do so could result in unnecessary jamming of the machine.
- To move a pile of processed material, use a spade, rake, or long handle tool. NEVER use your hands or feet!

To Free a Jammed Flywheel

! WARNING!

BEFORE PERFORMING ANY MAINTENANCE PROCEDURE OR INSPECTION, STOP THE ENGINE, WAIT FIVE (5) MINUTES TO ALLOW ALL MOVING PARTS TO COME TO A COMPLETE STOP AND COOL. DISCONNECT THE SPARK PLUG WIRE, KEEPING IT AWAY FROM THE SPARK PLUG.

Tool Needed:

(2) 1/2" Wrench or Socket

Disassemble:

1. Remove any material left in the Chipper Hopper and then remove the Deflector by removing the two (2) 5/16" x 4" Bolts (*Figure 5*).

! NOTICE!

NEVER PRY AGAINST THE SCROLL WHEN REMOVING THE DEFLECTOR, OR AT ANY OTHER TIME. THIS WILL CAUSE DAMAGE TO THE MACHINE.

2. Check to see if the Deflector or Discharge opening is clogged. If it is, clear it with a wooden stick.
3. Also with a wooden stick, loosen and remove any material left in the Chipping Chamber.

Reassemble:

1. Hold the Deflector (*Figure 5*) in place at the Discharge opening of the Chipper.
2. Place a 5/16" Flat Washer on a 5/16"-18 x 4" Bolt and then slide the Bolt through both the top two (2) holes of the Chipper body and the Deflector.

NOTE: Be certain that the Bolt attaching the Deflector to the Chipper passes through the Pipe (tube) welded to the Scroll (*Figure 5*).

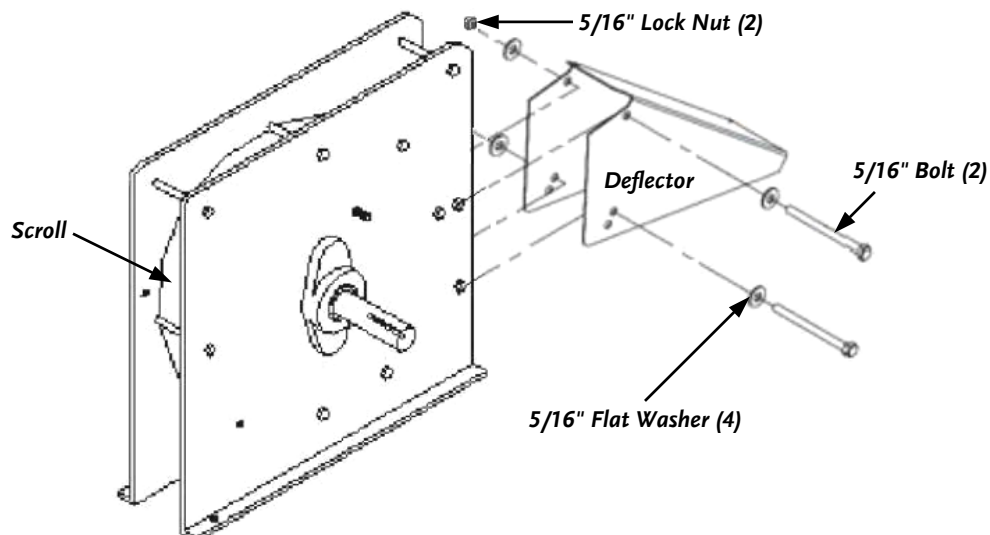

3. Add a 5/16" Flat Washer to the end of the Bolt followed by a 5/16"-18 Lock Nut. Do not tighten at this time.
4. Repeat Steps 2 and 3 for the lower Deflector attachment Bolt.
5. Pull up on the end of the Deflector and tighten the two (2) Lock Nuts.
6. Reconnect the Spark Plug wire and start the Chipper Engine; allowing any remaining material in the Chipping Chamber to discharge.
7. If the Chipping Chamber does not clear and the Flywheel is still jammed, repeat above process.
8. Be certain the Chipping Chamber is clear before trying to process more material into the Chipper Hopper, clogging could result in Belt or Clutch failure.

CHAPTER 5

MAINTAINING THE DR RANGER CHIPPER

This chapter covers regular maintenance procedures that will ensure the best performance and long life of your DR RANGER CHIPPER. For Engine maintenance, please refer to the Engine Owner's Manual that came with your DR RANGER CHIPPER. Service intervals listed in the checklist below supercede those listed in the Engine Owner's Manual.

WARNING!

BEFORE PERFORMING ANY MAINTENANCE PROCEDURE OR INSPECTION, STOP THE ENGINE, WAIT FIVE (5) MINUTES TO ALLOW ALL MOVING PARTS TO COME TO A COMPLETE STOP AND COOL. DISCONNECT THE SPARK PLUG WIRE, KEEPING IT AWAY FROM THE SPARK PLUG.

Regular Maintenance Check List

NOTE: Consider that the service intervals shown are the maximum under normal operating conditions. Increase frequencies under extremely dirty or dusty conditions.

Procedure	Before Each Use	Every 8 - 10 Hours	Every 40 Hours	Every 100 Hours
Check Engine Oil Level	▲			
Check General Equipment Condition	▲			
Check that the Shaft turns freely, see page 22	▲			
Inspect Knife for damage	▲			
Check Knife and Wear Plate for Sharpness		▲		
Check Knife and Wear Plate Attachment Screws		▲		
Check Knife to Wear Plate Gap		▲		
Check Side Bearing Collar Set Screws		▲		
Check Belt Tension and Condition	1 st time 1 hour	▲		
Lubricate Side Bearings		▲		
Clean Engine Exterior and Cooling Fins		▲		
Check the Tire Pressure			▲	
Change Engine Oil and Filter*	1 st time 5 hrs.		▲	
Replace Air Filter and Precleaner*			▲	
Replace Drive Belt				▲
Replace Spark Plug				▲

* The engine on your DR RANGER CHIPPER may not have a Precleaner or Oil Filter.

Grease Fittings

Your DR RANGER CHIPPER was greased at the Factory. The operator needs to lubricate the Chipper Side and Drive Side Bearings periodically.

! WARNING!

BEFORE PERFORMING ANY MAINTENANCE PROCEDURE OR INSPECTION, STOP THE ENGINE, WAIT FIVE (5) MINUTES TO ALLOW ALL MOVING PARTS TO COME TO A COMPLETE STOP AND COOL. DISCONNECT THE SPARK PLUG WIRE, KEEPING IT AWAY FROM THE SPARK PLUG.

Supplies Needed:

- Flexible hose grease gun
- Lithium grease
- Clean cloth
- 5/32" Allen Wrench
- Loctite® 243 (if needed)

1. Wipe all dirt, etc., from the Grease Fittings with a clean cloth (**Figure 6**).
2. Apply no more than three (3) pumps of quality general-purpose lithium grease with a hand-pumped grease gun to each Grease Fitting, one (1) on the Chipper Side Bearing, and one (1) on the Drive Side Bearing.

! NOTICE!

OVER LUBRICATION CAN ALSO DAMAGE THE BEARINGS.

3. After greasing, check the Side Bearing Collar Set Screws for tightness with a 5/32" Allen Wrench. If they are loose, reset them with Loctite® 243, obtainable at most hardware stores.

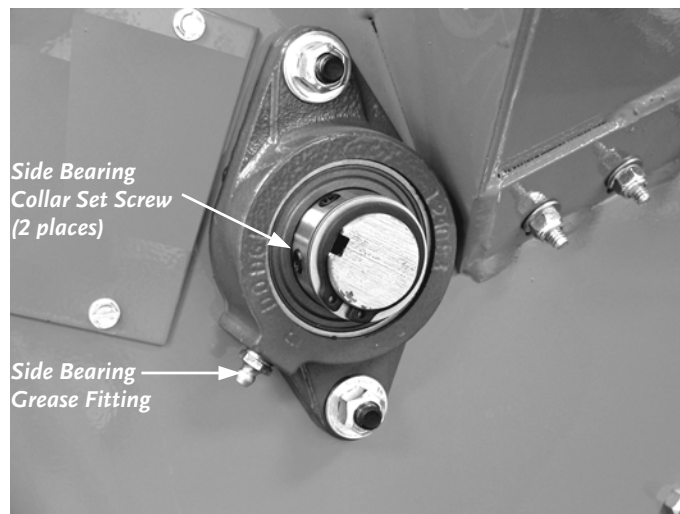

Figure 6

Removing and Replacing the Engine Oil

! WARNING!

BEFORE PERFORMING ANY MAINTENANCE PROCEDURE OR INSPECTION, STOP THE ENGINE, WAIT FIVE (5) MINUTES TO ALLOW ALL MOVING PARTS TO COME TO A COMPLETE STOP AND COOL. DISCONNECT THE SPARK PLUG WIRE, KEEPING IT AWAY FROM THE SPARK PLUG.

Tools and Supplies Needed:

- SAE 30 HD Oil (see the table on page 14)
- Suitable container for used oil
- Rags

NOTE 1: The Engine is equipped with a Drain Valve for ease in changing the oil (**Figure 7**).

NOTE 2: Drain the oil when the Engine is warm; warm oil drains quickly and completely.

1. Position a suitable oil receptacle under the Engine Oil Drain Valve (located at the Handlebars side of the Engine) and remove the Engine Oil Fill Cap (**Figure 7**).
2. Open the Engine Oil Drain Valve by twisting the valve end counterclockwise and then pull out (**Figure 7**). Allow the used oil to drain completely, and then close the Drain Valve (push in and turn clockwise).
3. Replace the Engine oil using SAE 30 HD oil. See page 14.
4. Reattach the Spark Plug wire.

NOTE: If you are not reusing the oil, be sure to use environmentally safe disposal procedures in the disposing of the used oil.

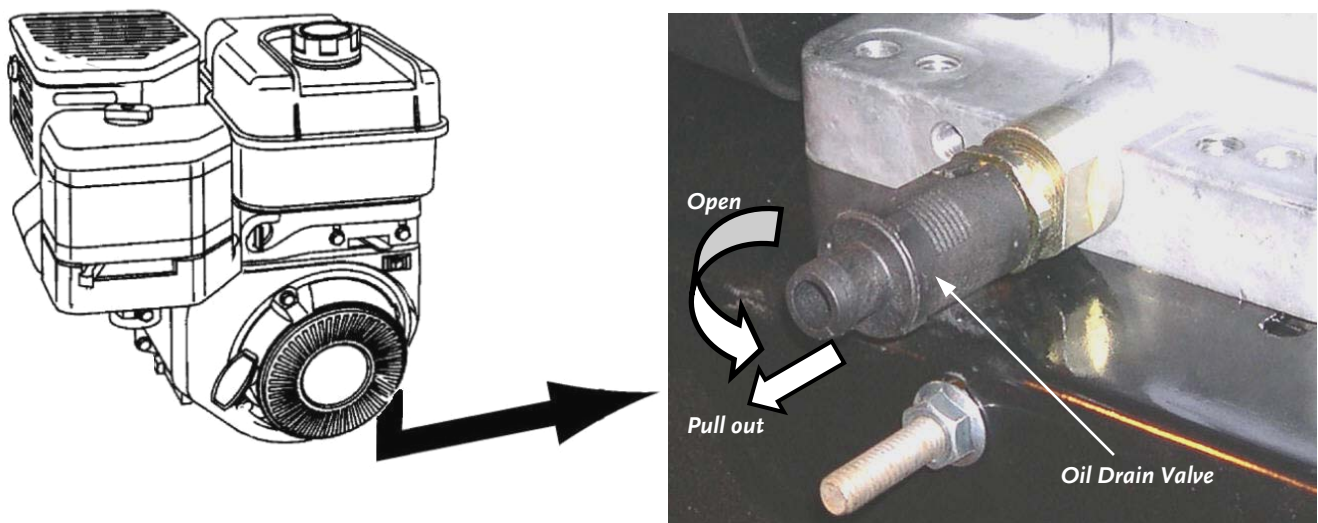

Figure 7

Adjusting or Removing and Replacing the Drive Belt

! WARNING!

BEFORE PERFORMING ANY MAINTENANCE PROCEDURE OR INSPECTION, STOP THE ENGINE, WAIT FIVE (5) MINUTES TO ALLOW ALL MOVING PARTS TO COME TO A COMPLETE STOP AND COOL. DISCONNECT THE SPARK PLUG WIRE, KEEPING IT AWAY FROM THE SPARK PLUG.

! NOTICE!

USE ONLY A DR BELT ON YOUR MACHINE. THE BELT HAS BEEN THOROUGHLY TESTED AND PROVEN FOR MANY HOURS OF USE.

The belt on your DR RANGER CHIPPER should deflect $3/8$ " under approximately three (3) pounds of pressure as shown in **Figure 8**; if it does not, adjust per the following directions.

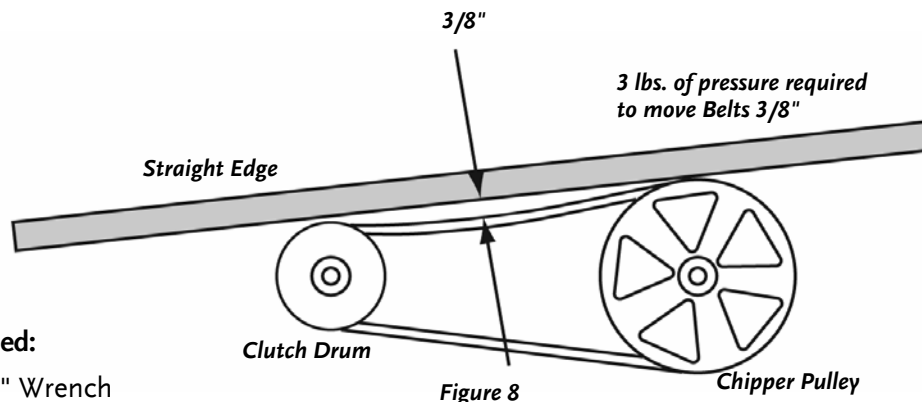

Tools Needed:

- (2) $1/2$ " Wrench
- $5/32$ " Allen Wrench
- Loctite® 243 (if needed)

1. Remove the Belt Guard by removing the Retaining Bolts using a $1/2$ " Wrench.
2. Loosen the four (4) Engine Bolts (2 in the Front and 2 in the Rear) using two (2) $1/2$ " Wrenches, one (1) on the Bolt and one (1) on the Nut underneath (**Figure 9** on page 29).
3. Tighten or loosen the nut on the Belt Tensioner (**Figure 9** on page 29) using a $1/2$ " Wrench until you have the correct tension as shown in **Figure 8**.
4. Retighten the four (4) Engine Bolts.
5. Check the alignment of the Clutch with the Drive Pulley by placing a straightedge across both faces as shown in **Figure 10** on page 29. If adjustment is necessary, correct the alignment as follows:
 - a) Remove the two (2) Set Screws in the Drive Pulley Hub with a $5/32$ " Allen Wrench (**Figure 11** on page 30) and set them aside.
 - b) Using a straightedge, align the Clutch and Drive Pulley as shown in **Figure 10** by moving the Drive Pulley in or out on the Rotor Shaft (**Figure 11** on page 30). **Do not make the adjustment by moving the Clutch on the Engine Shaft.**

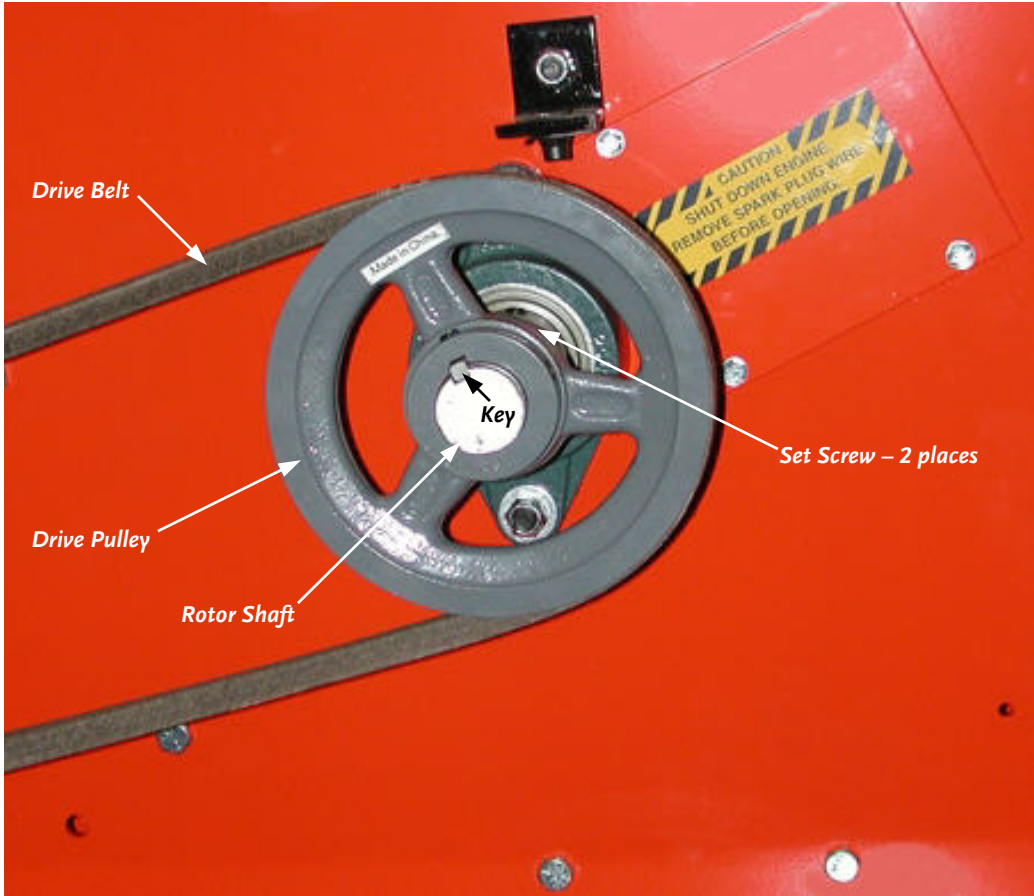

Figure 11

Removing and Replacing the Chipper Knife

! NOTICE!

ROUTINELY CHECK THE CHIPPER KNIFE FOR SHARPNESS. USING A DULL KNIFE WILL DECREASE PERFORMANCE AND CAUSE EXCESSIVE VIBRATION THAT WILL CAUSE DAMAGE TO THE DR RANGER CHIPPER ENGINE.

! WARNING!

BEFORE PERFORMING ANY MAINTENANCE PROCEDURE OR INSPECTION, STOP THE ENGINE, WAIT FIVE (5) MINUTES TO ALLOW ALL MOVING PARTS TO COME TO A COMPLETE STOP AND COOL. DISCONNECT THE SPARK PLUG WIRE, KEEPING IT AWAY FROM THE SPARK PLUG.

Knife Sharpening

- You should never attempt to sharpen the Chipper Knife freehand.
- It is extremely important to consistently maintain the 45-degree angle for proper performance.
- Excessive heat generated during the sharpening process will damage Knives and weaken the metal. Be sure not to overheat the Knife during sharpening because it will shorten the life of the Knife.
- Take the Chipper Knife to a machine shop for proper sharpening.
- How many times a Knife can be sharpened is determined by how much material needs to be taken off to sharpen or to compensate for dents or gouges.
- A new Chipper Knife has 5/16" measurement between the short side bevel edge and the Knife mounting holes. See **Figure 12**.

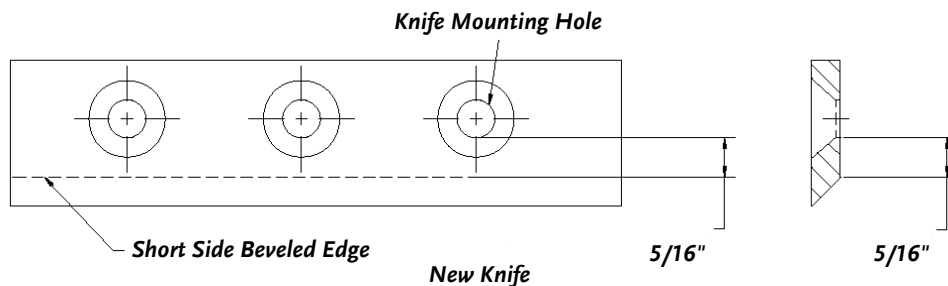

Figure 12

- The knife should never be sharpened to the extent that more than 3/32" is taken off this measurement.
- Once this measurement is below 7/32" (see **Figure 13**), or if you are unable to remove dents or gouges with these guidelines, replace the Knife.

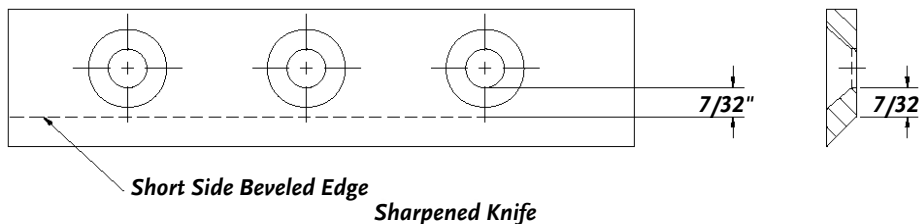

Figure 13

Tools Needed:

- 5/16" Wrench
 - 3/16" Allen wrench
 - 1/2" Socket and Ratchet
1. Using a 5/16" Wrench, remove both Access Covers (Chipper and Drive Side) from the Chipper Box (**Figure 14**).
 2. Rotate the Chipper Disk using a stick until the three (3) countersunk Allen Screws and Lock Nuts attaching the Knife to the Flywheel are visible through the Access Openings (**Figure 14**).
 3. Clean out the heads of the Allen Screws with an awl or sharp tool.
 4. Insert a 3/16" Allen wrench into the head of a Screw.
 5. While holding the Allen wrench, remove the Lock Nut using a 1/2" Socket.
 6. Repeat Steps 4 and 5 for the remaining two (2) Allen Screws.
 7. Remove the dull or damaged Knife and visually inspect the Chipper Disk Slot and Knife mounting area and be sure they are clean. Metal burrs may need filing so that the replacement Knife will be able to mount flush against the Chipper Disk.
 8. Install a new or sharpened Knife and finger tighten the Allen screws and Lock Nuts (new hardware is supplied with a new Knife) to hold the Knife to the Chipper Disk.
 9. Using a 3/16" Allen Wrench and a 1/2" Socket, tighten the center Screw and Nut, then tighten the outer Screw and Nut, and finally tighten the inner Screw and Nut.
 10. Double-check all three (3) Screws and Nuts for tightness one more time.
 11. Replace the Access Covers.
 12. Check the gap between the Knife and Wear Plate. See "Adjusting the Knife to Wear Plate Gap" on page 33.

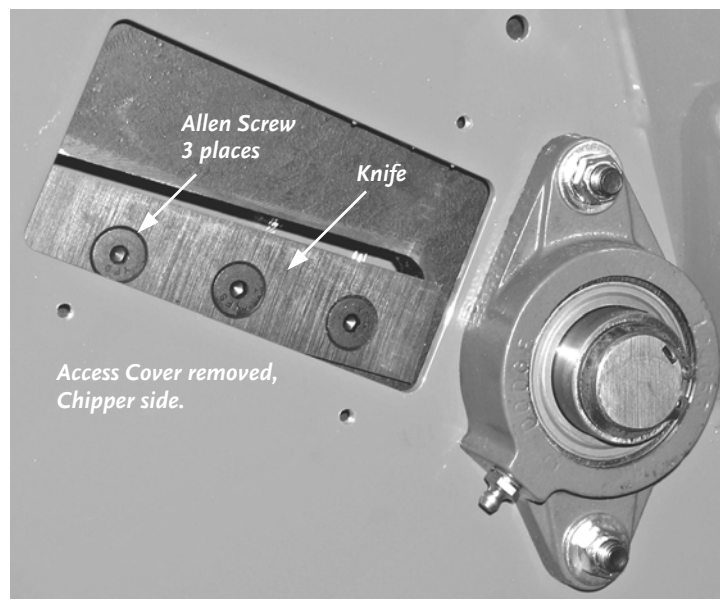

Figure 14

Adjusting the Knife to Wear Plate Gap

When you replace the Knife, check and set the clearance between the Knife and Wear Plate. Set this clearance or gap to 1/16" (**Figure 15**). If the gap between the Wear Plate and the Knife is not set correctly, you will have excessive vibration when chipping and the Knife will seem to be dull. The Wear Plate should have a square edge and be free of dents or gouges. The Wear Plate can be hand sharpened. Be careful not to overheat it during the sharpening process. This will change the characteristics of the steel and you will then have to replace the Wear Plate.

! WARNING!

BEFORE PERFORMING ANY MAINTENANCE PROCEDURE OR INSPECTION, STOP THE ENGINE, WAIT FIVE (5) MINUTES TO ALLOW ALL MOVING PARTS TO COME TO A COMPLETE STOP AND COOL. DISCONNECT THE SPARK PLUG WIRE, KEEPING IT AWAY FROM THE SPARK PLUG.

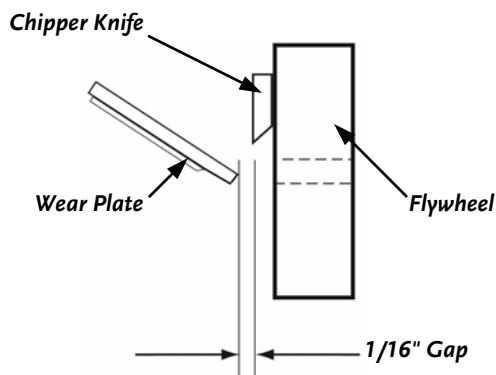

Figure 15

Tools Needed:

- (2) 1/2" Wrench or Socket
- 7/16" Wrench or Socket
- Gap Gauge (provided)

1. Remove the Chipper Hopper by performing the steps on page 13 in the reverse order.
2. Rotate the Chipper Disk using a stick until the Knife is opposite the Wear Plate.
3. To adjust the Wear Plate Gap, loosen the three (3) 1/4" Nuts and Bolts while holding the Wear Plate in place. Now you can slide the Wear Plate up or down (in or out) to achieve the correct gap setting.
4. Take the Gap Gauge and slide it between the Knife and Wear Plate. If the gap is set correctly, the Gap Gauge will lightly touch both the Knife and Wear Plate. If the gap is too small, you will not be able to get the Gauge between the Knife and Wear Plate. If the gap is too large, there will be excess room between Gap Gauge, Knife, and Wear Plate.
5. Tighten the Nuts and Bolts when the Wear Plate is in the correct position (**Figure 15**).
6. Replace the Chipper Hopper.

! NOTICE!

AFTER ANY KNIFE OR WEAR PLATE MAINTENANCE OR ADJUSTMENT, ROTATE THE CHIPPER DISK BY USING A WOODEN STICK AND WATCH AND LISTEN CAREFULLY FOR ANY UNUSUAL NOISES, CLICKING OR VIBRATION. IF YOU DETECT ANY OF THESE, INSPECT THE MACHINE FOR DAMAGE, OR ANY LOOSE PARTS. REPAIR OR REPLACE ANY DAMAGED PARTS AND TIGHTEN ANY LOOSE PARTS BEFORE STARTING THE DR RANGER CHIPPER.

Removing and Replacing the Clutch

WARNING!

BEFORE PERFORMING ANY MAINTENANCE PROCEDURE OR INSPECTION, STOP THE ENGINE, WAIT FIVE (5) MINUTES TO ALLOW ALL MOVING PARTS TO COME TO A COMPLETE STOP AND COOL. DISCONNECT THE SPARK PLUG WIRE, KEEPING IT AWAY FROM THE SPARK PLUG.

The design of the Clutch on your machine is for rugged, dependable service, however, it is important to understand the limitations of a Clutch. The Clutch design is to provide load free starting of the Engine, and slippage under excessive overloading of the driven application. These features help protect the Engine from damages such as broken crankshafts and starters. The Shoes and Springs on the Clutch are normal wear items. If you notice decreased performance of the Clutch, check and replace them if necessary.

The Clutch obtains its power from the Engine RPM. The lower the engagement speed, and the higher the maintained Engine speed, the more torque the Clutch can transfer to the driven unit. **NEVER operate the DR RANGER CHIPPER Engine at less than full RPM.**

***NOTE:** At Engine start-up, the Engine of your chipper operates under no load until approximately 1100-1200 RPM, at which speed the centrifugal clutch engages and begins driving the rotor. Proper rotor speed is 2400-RPM +/- 200 RPM.*

NOTICE!

- **DO NOT TAMPER WITH THE ENGINE'S GOVERNOR SETTING. THE GOVERNOR CONTROLS THE MAXIMUM SAFE OPERATION SPEED AND PROTECTS THE ENGINE. OVER-SPEEDING THE ENGINE IS DANGEROUS AND WILL CAUSE DAMAGE TO THE ENGINE AND TO THE OTHER MOVING PARTS OF THE MACHINE. SEE YOUR AUTHORIZED DEALER FOR ANY ENGINE GOVERNOR ADJUSTMENTS.**
 - **BECOME FAMILIAR WITH SUCCESSFUL OPERATING CONDITIONS AND AVOID THOSE THAT CAN OVERLOAD AND DAMAGE THE MACHINE.**
 - **DO NOT OVERLOAD OR ATTEMPT TO CHIP MATERIAL BEYOND THE MANUFACTURERS RECOMMENDATION. PERSONAL INJURY OR DAMAGE TO THE MACHINE COULD RESULT. LEARN TO RECOGNIZE THE SOUND OF THE MACHINE DURING AN OVERLOAD CONDITION. ONLY YOUR OPERATOR EXPERIENCE WILL TELL YOU HOW FAST YOU CAN SUCCESSFULLY FEED MATERIAL INTO THE MACHINE.**
 - **IF OVERLOADING OR ANY OTHER CAUSE JAMS THE MACHINE, STOP THE MACHINE IMMEDIATELY. IF YOU JAM THE MACHINE AND DO NOT STOP THE ENGINE, IT CAN BURN THE DRIVE BELT AND/OR RUIN THE CLUTCH. CLUTCH DAMAGE CAN BE COSTLY AND IT MAY NOT BE COVERED UNDER WARRANTY. FOR THIS REASON, IT IS IMPORTANT THAT YOU IMMEDIATELY SHUT OFF THE MACHINE IF IT BECOMES JAMMED.**
 - **THE CENTRIFUGAL CLUTCH ON THIS MACHINE IS PERMANENTLY LUBRICATED AND DOES NOT REQUIRE OIL OR GREASE. IF, AFTER LONG PERIODS OF USE, THE DRUM WOBBLER EXCESSIVELY, REPLACE THE DRUM ASSEMBLY. ALWAYS REPLACE THE SHOES AND SPRINGS IN SETS. WHENEVER THE SHOES ARE CHANGED; REPLACE ALL SPRINGS.**
-

Installing a New Clutch Assembly

If you have problems with the Clutch, we recommend replacing your Clutch as a complete assembly.

Tools and Supplies Needed:

- (2) 1/2" Wrench
- 9/16" Socket w/Extension
- Anti-seize compound

1. Remove the Belt Guard and loosen the Engine Bolts as outlined in Steps 1 and 2 on page 28.
2. After you have loosened the Engine Bolts, remove the Drive Belt and set it aside.
3. Remove the Clutch from the engine crankshaft by removing the 3/8" Bolt, Lock Washer, and Flat Washer and then slide the Clutch Assembly from the crankshaft.

NOTE: *The shim behind the Clutch remains on the engine crankshaft.*

4. Remove the Key from the keyway in the Engine Crankshaft and set it aside.
5. Clean the Engine Crankshaft and remove any burrs, then apply anti-seize compound to the Crankshaft.
6. Install the Key in the keyway of the new Clutch hub, align the Key with the slot in the Engine Crankshaft, and then slide the new Clutch Assembly onto the Crankshaft followed by the 3/8" Flat Washer, Lock Washer, and the 3/8" Bolt. Tighten the Bolt securely.
7. Reinstall the Drive Belt and set the Drive Belt tension and alignment per Steps 3 through 5 on page 28.
8. Reinstall the Belt Guard.

Clutch Removal, Disassembly, and Re-Assembly

If it is necessary to disassemble your Clutch, follow these steps.

Tools and Supplies Needed:

- 9/16" Socket w/Extension
- Pliers, Retainer Ring
- Pliers (wrap the gripping surface in tape to avoid scratching the spring surface)
- Anti-seize compound

1. Perform steps 1 through 4 on the previous page to remove the Clutch.
2. Remove the Retainer Ring and Flat Washer and slide the Hub out of the Drum Assembly (**Figure 16**).
3. Unhook one Spring from its Shoe (**Figure 16**).

NOTE: Use Tape Wrapped Pliers to avoid nicking the Spring.

4. Carefully note the position of Shoes and remove Shoes from the Hub (**Figure 16**).
5. Position the new Shoes correctly on the Hub, noting how the old ones were removed.
6. Place one end of each Spring over a Shoe Pin, stretch the Spring just enough to clear the Pin on the other Shoe. Use Tape Wrapped Pliers to avoid nicking the Spring. Avoid over stretching that may damage the Spring. Repeat for all Shoes.
7. Reassemble the Drum to the Hub, reinstall the Washer on Hub Shaft, and secure in place with the Retainer Ring (**Figure 16**).
8. Clean the Engine Crankshaft and remove any burrs, then apply anti-seize compound to the Crankshaft.
9. Install the Key in the keyway of the Clutch Hub, align the Key with the slot in the Engine Crankshaft, and then slide the rebuilt Clutch Assembly onto the Crankshaft followed by the 3/8" Flat Washer, Lock Washer and 3/8" Bolt. Tighten the Bolt securely.
10. Reinstall the Drive Belt and set the Drive Belt tension and alignment per Steps 3 through 5 on page 28.
11. Reinstall the Belt Guard.

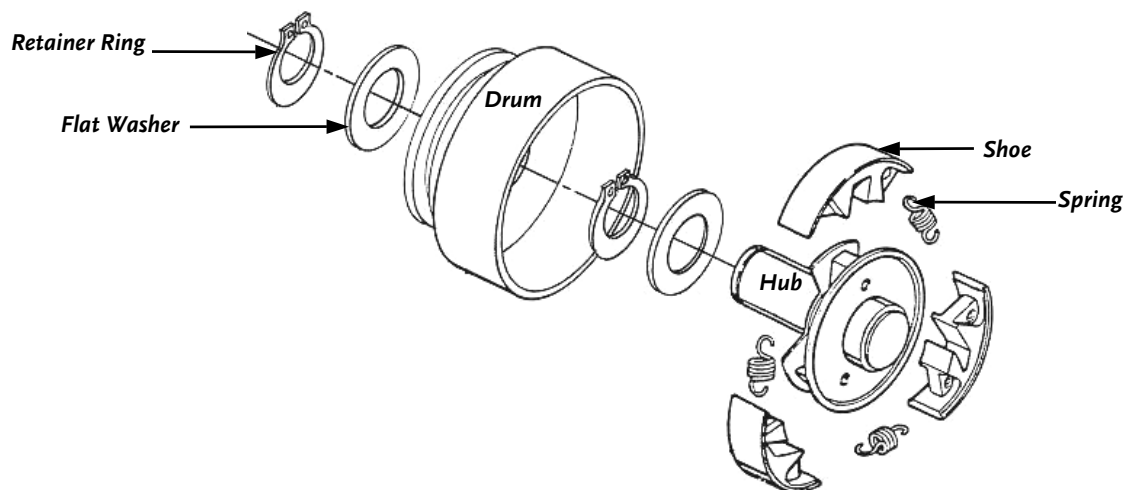

Figure 16

End of Season and Storage

WARNING!

- **BEFORE PERFORMING ANY MAINTENANCE PROCEDURE OR INSPECTION, STOP THE ENGINE, WAIT FIVE (5) MINUTES TO ALLOW ALL MOVING PARTS TO COME TO A COMPLETE STOP AND COOL. DISCONNECT THE SPARK PLUG WIRE, KEEPING IT AWAY FROM THE SPARK PLUG.**
 - **NEVER STORE THE DR RANGER CHIPPER WITH FUEL IN THE FUEL TANK INSIDE A BUILDING WHERE IGNITION SOURCES ARE PRESENT, SUCH AS HOT WATER AND SPACE HEATERS, CLOTHES DRYERS AND THE LIKE. IF YOU ARE GOING TO DRAIN THE FUEL TANK, DO THIS OUTDOORS. ALLOW THE ENGINE TO COOL BEFORE STORING IN ANY ENCLOSURE.**
 - **WHEN NOT IN USE, YOUR DR RANGER CHIPPER SHOULD BE STORED OUT OF THE REACH OF CHILDREN AND IN A DRY LOCATION.**
-

***NOTE:** Please refer to the Engine Owner's Manual for engine-specific procedures.*

- Check the Chipper Knife and Wear Plate for nicks and wear.
- Check the Drive Belt for wear.
- Change the oil (and oil filter, if applicable).
- Lubricate all Grease Fittings. See page 26.
- Remove the Spark Plug and pour about 1 ounce of motor oil into the Cylinder Hole. Reinstall the Plug and pull the Recoil Starter Rope until you feel strong resistance. This will coat the Piston and seat the Valves to prevent moisture buildup.
- Clean or replace the Air Filter.
- Clean any dirt and debris from the Cylinder Head Cooling Fins, Blower Housing, Debris Screen, and Muffler area of the Engine.
- If your Engine has a Fuel Filter, replace it.
- If your DR RANGER CHIPPER will be idle for more than 30 days, we recommend using a gas stabilizer. This will prevent sediment from gumming up the Carburetor. If there is dirt or moisture in the Gas or Tank, remove it by draining the Tank. Completely fill the Tank with fresh, unleaded Gas and add the appropriate amount of Stabilizer or Gasoline Additive. Run the Engine for a short time to allow the additive to circulate. Close the Fuel Shut-Off Valve to prevent Carburetor overflow and leakage.

CHAPTER 6

TROUBLESHOOTING

Most problems are easy to fix. Consult the Troubleshooting Table below for common problems and their solutions. If you continue to experience problems, call Country Home Products, Inc. for support.

Troubleshooting Table



WARNING!

BEFORE PERFORMING ANY MAINTENANCE PROCEDURE OR INSPECTION, STOP THE ENGINE, WAIT FIVE (5) MINUTES TO ALLOW ALL MOVING PARTS TO COME TO A COMPLETE STOP AND COOL. DISCONNECT THE SPARK PLUG WIRE, KEEPING IT AWAY FROM THE SPARK PLUG.

SYMPTOM	POSSIBLE CAUSE
<i>Recoil will not pull out or is difficult to pull.</i>	<ul style="list-style-type: none"> ⇒ Remove any built-up debris from the Chipper Hopper Inlet and Discharge Chute. ⇒ Check the Engine oil level, the Engine may be seized. ⇒ There may be an oil compression lock in the Cylinder. Take out the Spark Plug; hold a rag over the Spark Plug Hole and pull the Recoil Cord several times to blow out any oil in the Cylinder. Wipe off the Spark Plug and reinstall it. ⇒ The Recoil may be broken or jammed. Try to turn the Engine Pulley by hand, with the Spark Plug wire off. If it turns, the Recoil is broken or jammed. Call 1-800-DR-OWNER (376-9637) for assistance.
<p><i>The Engine will not start.</i></p> <p><i>(Please refer to the Engine Owner's Manual for engine-specific procedures.)</i></p>	<ul style="list-style-type: none"> ⇒ Make sure the Spark Plug wire is securely attached. ⇒ Make sure the Fuel Shut-Off Valve is in the ON position. ⇒ Check the oil and gas level. See page 14. ⇒ The gas may be old, change it. Use a Fuel Stabilizer if you keep gas longer than one month. ⇒ Check the Fuel Filter to see if it is clear. Place a can under the Fuel Filter and remove the Fuel Line from the Engine side of the Filter. If gas flows freely, it is OK. ⇒ Check the Throttle adjustment and travel. ⇒ The Spark Plug may be dirty or cracked, change it. If it's oily, leave it out, hold a rag over the Plug hole and pull the Recoil Cord several times to blow out any oil in the Cylinder, then wipe off the Plug and reinsert it. ⇒ The Air Filter may be dirty, change it following the procedure in the Engine Owner's Manual. ⇒ If the Engine still will not start, call 1-800-DR-OWNER (376-9637) for assistance.

! WARNING!

BEFORE PERFORMING ANY MAINTENANCE PROCEDURE OR INSPECTION, STOP THE ENGINE, WAIT FIVE (5) MINUTES TO ALLOW ALL MOVING PARTS TO COME TO A COMPLETE STOP AND COOL. DISCONNECT THE SPARK PLUG WIRE, KEEPING IT AWAY FROM THE SPARK PLUG.

SYMPTOM	POSSIBLE CAUSE
<p><i>The Engine lacks power or is not running smoothly.</i></p> <p><i>(Please refer to the Engine Owner's Manual for Engine-specific procedures.)</i></p>	<ul style="list-style-type: none"> ⇒ Check the Throttle Lever travel and adjustment. The Throttle Lever should be in the Run position. ⇒ Is the Choke Lever pushed all the way to the left (RUN)? ⇒ The Air Filter may be dirty, change it following the procedure in the Engine Owner's Manual. ⇒ The Spark Plug may be dirty or cracked, change it. If it's oily, leave it out, hold a rag over the Plug hole and pull the Recoil Cord several times to blow out any oil in the Cylinder, then wipe off the Plug and reinsert it. ⇒ The gas may be old, change it. Use a fuel stabilizer if you keep gas longer than one month. ⇒ The Engine may not have the right amount of clean oil. If it is dirty, change it following the procedure on page 27. ⇒ If your Engine still lacks power, call 1-800-DR-OWNER (376-9637) for assistance.
<p><i>Engine smokes.</i></p>	<ul style="list-style-type: none"> ⇒ Check the oil level and adjust as needed. ⇒ You may be operating the machine on too great an incline. The machine should be level. ⇒ Check the Air Filter and clean or replace if needed. ⇒ You may be using the wrong oil - too light for the temperature. Refer to your Engine Owner's Manual for detailed information. ⇒ Clean the Engine Cooling Fins and the Carburetor Housing if they are dirty. ⇒ If the Engine still smokes, call 1-800-DR-OWNER (376-9637) for assistance.
<p><i>Flywheel will not turn.</i></p>	<ul style="list-style-type: none"> ⇒ The Flywheel may be jammed. Immediately stop the Engine. Remove any built-up debris from the Chipper Hopper Inlet and Discharge Chute. ⇒ Check the Drive Pulley alignment and adjust if necessary. ⇒ Check the Drive Belt tension. See page 28. ⇒ Replace the Drive Belt or reinstall if the Belt has come off the Pulleys. ⇒ Turn the Flywheel with a wooden stick to be sure it turns freely. If the Flywheel still will not turn, call 1-800-DR-OWNER (376-9637) for assistance.
<p><i>Drive Belt burns.</i></p>	<ul style="list-style-type: none"> ⇒ The Chipper is being overloaded; process material at a slower rate. ⇒ The Flywheel is jammed. See the Symptom above. ⇒ If the Drive Belt still burns, call 1-800-DR-OWNER (376-9637) for assistance.

! WARNING!

BEFORE PERFORMING ANY MAINTENANCE PROCEDURE OR INSPECTION, STOP THE ENGINE, WAIT FIVE (5) MINUTES TO ALLOW ALL MOVING PARTS TO COME TO A COMPLETE STOP AND COOL. DISCONNECT THE SPARK PLUG WIRE, KEEPING IT AWAY FROM THE SPARK PLUG.

SYMPTOM	POSSIBLE CAUSE
<i>The Drive Belt frays or rolls over the Drive Pulley.</i>	<ul style="list-style-type: none"> ⇒ The Rotor Drive Pulley Groove may be nicked. File off any nicks on the Pulley. ⇒ Check the Drive Belt for wear and hard spots. The Drive Belt may be stretched; replace it. See page 28. ⇒ If the Drive Belt still rolls off the Drive Pulley, call 1-800-DR-OWNER (376-9637) for assistance.
<i>Engine runs but the Flywheel does not rotate.</i>	<ul style="list-style-type: none"> ⇒ The Inner Shoes of the Clutch are worn and/or the Clutch Shoe Retaining Springs are weak or broken. Replace worn or broken Clutch parts. See page 35. ⇒ Loose Drive Belt; adjust the Drive Belt tension. See page 28. ⇒ Remove any built-up debris from the Chipper Hopper Inlet and Discharge Chute.
<i>Chipping action seems too slow or Flywheel stalling.</i>	<ul style="list-style-type: none"> ⇒ The Engine speed is too slow causing the Belt to slip. Run the Engine at full throttle. ⇒ Check for a loose Drive Belt and tighten. See Page 28. ⇒ Check for a damaged Drive Belt and replace the Belt if necessary. See page 28. ⇒ Check the sharpness of the Chipping Knife.
<i>The machine has excessive vibration.</i>	<ul style="list-style-type: none"> ⇒ The Knife may not be seated properly on the Flywheel. Loosen the Knife Mounting Screws, reset the Knife, and tighten the Screws. Also, check the Wear Plate Gap. See page 33. ⇒ Check for a broken or dull Chipping Knife. ⇒ If the machine still exhibits excessive vibration, call 1-800-DR-OWNER (376-9637) for assistance.
<i>When chipping, the log seems to vibrate excessively and “hammers” my hands.</i>	<ul style="list-style-type: none"> ⇒ The Knife is dull; sharpen or replace it. See page 31. ⇒ The gap between the Knife and Wear Plate is too great; adjust the Gap. See page 33.
<i>Chipper Knife is hitting the Wear Plate.</i>	<ul style="list-style-type: none"> ⇒ The gap between the Knife and the Wear Plate is set incorrectly; adjust the Wear Plate Gap. See page 33.
<i>The machine is hard to push or veers left or right.</i>	<ul style="list-style-type: none"> ⇒ Check the Tire pressure. There should be 30 psi in each Tire.

PARTS LISTS, SCHEMATIC DIAGRAMS AND WARRANTY

Parts List - DR RANGER CHIPPER

NOTE: Part numbers listed are available through Country Home Products, Inc.

Ref#	Part#	Description	Ref#	Part#	Description
01	16193	Engine, 13.5 Ft.-Lbs. Intek, B&S	20	14075	Clutch Assembly, 1" Bore
02	15979	Bolt, 5/16"-18 x 1-3/4", HHCS	21	14229	Key, 1/4" x 1/4" x 1-1/4"
03	20881	Grip, Handle, 1" ID x 5" Long (Black)	22	16208	Washer, Flat, 3/8"
04	13443	Bolt, 5/16"-18 x 1-1/2", HHCS	23	21651	Washer, Lock, Split, 3/8"
05	20741	Brace, Handle, LH (Kit)	24	14445	Bolt, 3/8"-24 x 1-1/4", HHCS, GR 8
06	14605	Bolt, 5/16"-18 x 1", HHCS	25	14606	Set Screw, 5/16"-18 x 5/16"
07	18584	Tensioner, Belt	26	14231	Pulley
08	14313	Nut, Lock, Nylon, 5/16"-18	27	20851	Belt Guard Assembly
09	14515	Washer, Flat, 5/16", USS, Plated	28	15511	Washer, Lock, Split, 5/16"
10	21649	Foot, Front	29	14071	Belt, Drive, 5H570
11	20741	Brace, Handle, RH (Kit)	30	20242	Frame
12	19499	Bracket, Mounting, Belt Guard (Engine Base)	31	18589	U-Nut, 5/16"-18
13	21650	Rivet, Blind, 3/16" Dia., #68, Alum.	32	21652	Bracket, Mounting, Belt Guard (Forward)
14	16973	Axle, 5/8" x 28-1/4"	33	15539	Bolt, 5/16"-18 x 4", HHCS
15	18586	Bracket, Axle, Universal	34	14843	Deflector
16	18617	Spacer, 7/8"	35	21661	Chipper, C10
17	15465	Wheel, Pneumatic, 4.10/3.50" x 4"	36	19704	Nipple, Galvanized
18	18322	Shim, 1.500" x 1.015" x .125"	37	19703	Coupling
19	15488	Cap, Push	38	19425	Oil Drain

Schematic - DR RANGER CHIPPER

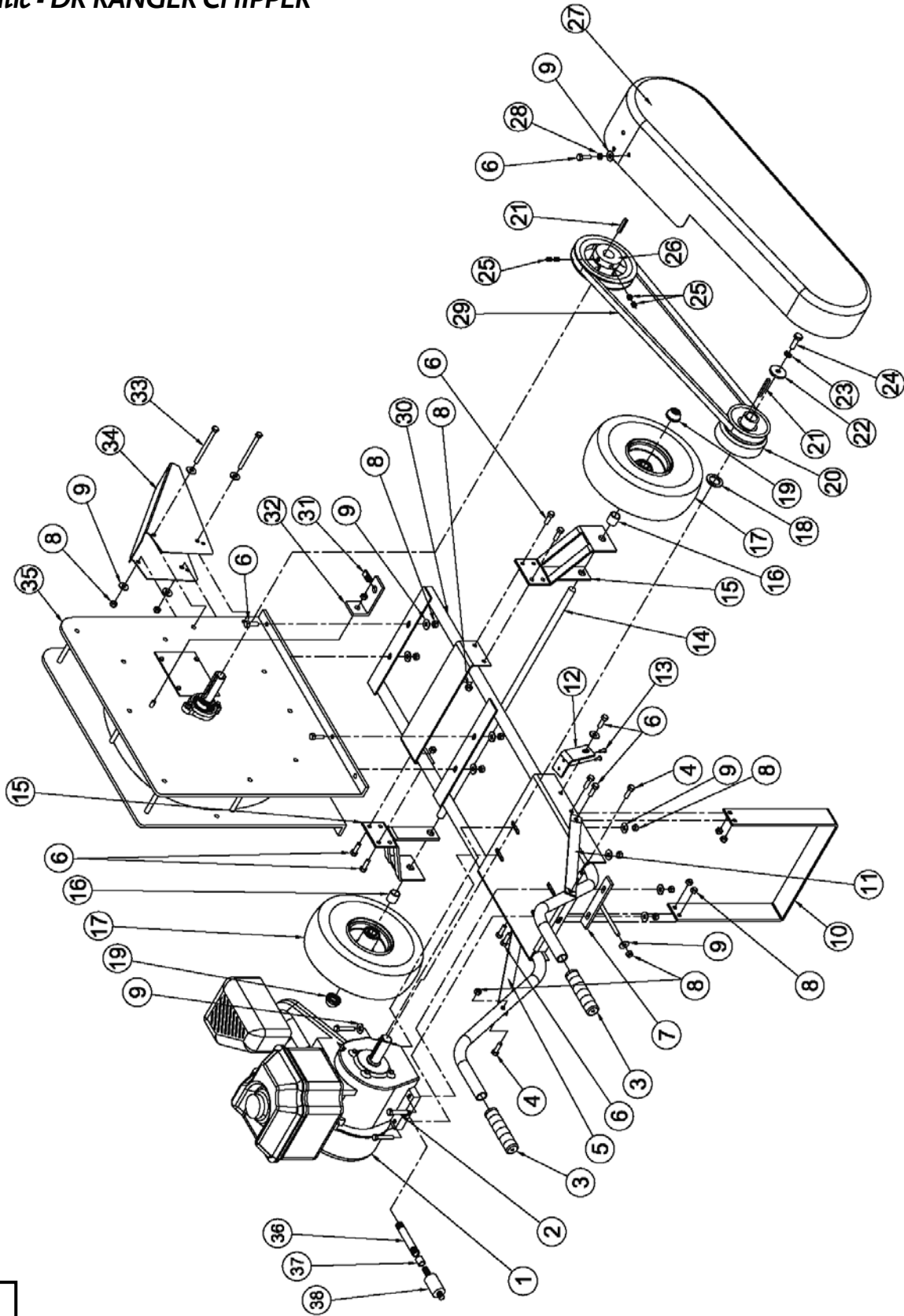

060120

Parts List - Chipper Assembly

NOTE: Part numbers listed are available through Country Home Products, Inc.

Ref#	Part#	Description
01	18301	Ring, Retaining
02	15526	Shim
03	15512	Screw, 10-32 x 3/8"
04	16798	Cover, Access
05	21636	Panel, Drive Side
06	14313	Nut, Lock, Nylon, 5/16"-18
07	20048	Knife (Kit)
08	15905	Bolt, 5/16"-18 x 1-1/2" FSHCS
09	21637	Chipper Disk and Shaft Assembly
10	20088	Scroll
11	21638	Panel, Chipper Side
12	18605	Bearing
13	21690	Nut, Lock, 3/8"-16
14	14515	Washer, Flat, 5/16" USS
15	14340	Nut, Lock, Nylon, 1/4"-20
16	14339	Washer, Flat, 1/4" SAE
17	15539	Bolt, 5/16"-18 x 4" HHCS
18	20212	Nut, Lock, Nylon, 10-24
19	20213	Screw, 10-24 x 3/4" PHMS
20	20833	Shield, Blow Back
21	14529	Bolt, Carriage, 5/16"-18 x 3/4"
22	20211	Chipper Hopper (Kit)
23	18264	Plate, Wear (Kit)
24	19566	Bolt, Carriage, 1/4"-20 x 1"
25	15449	Bolt, 3/8"-16 x 1-1/4" HHCS
26	18313	Tube, Scroll
27	18613	Nut, Lock, 5/16"-18

Not Illustrated

20014 Strip, Mounting, Blow Back Shield

Schematic - Chipper Assembly

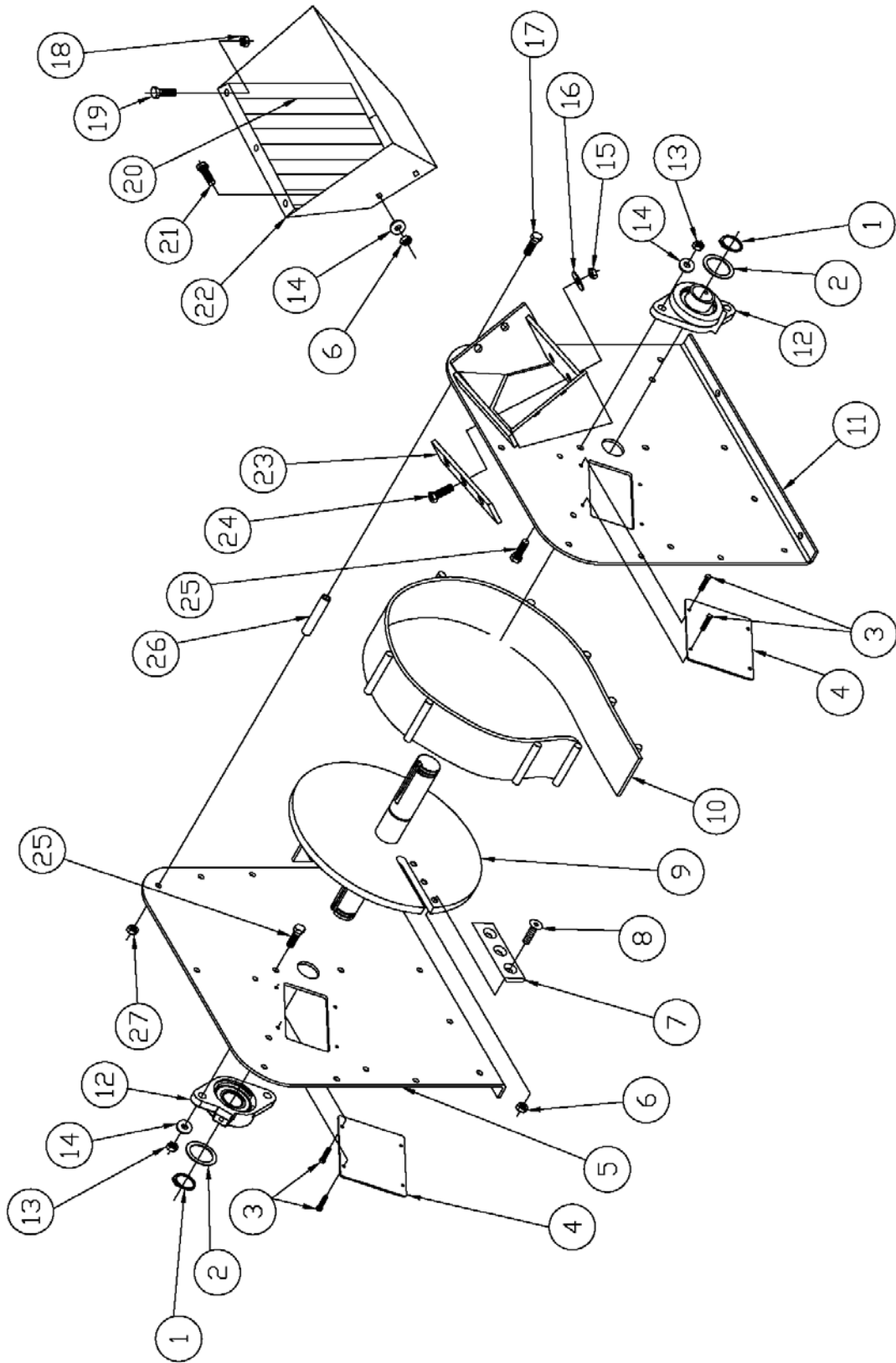

060101

Notes

DR[®] RANGER CHIPPER



2-Year Limited Warranty

Terms and Conditions

The DR[®] RANGER CHIPPER is warranted for two (2) years against defects in materials or workmanship when put to ordinary and normal consumer use; ninety (90) days for any other use. The engine manufacturer warrants the engine separately.

For the purposes of all the above warranties, "ordinary and normal consumer use" refers to non-commercial residential use and does not include misuse, accidents or damage due to inadequate maintenance.

Country Home Products, Inc. (home of DR[®] Power Equipment) certifies that the DR[®] RANGER CHIPPER is fit for ordinary purposes for which a product of this type is used. Country Home Products, Inc. however, limits the implied warranties of merchantability and fitness in duration to a period of two (2) years in consumer use, ninety (90) days for any other use.

The 2-Year Limited Warranty on the DR[®] RANGER CHIPPER starts on the date the machine ships from our factory. The 2-Year Limited Warranty is applicable only to the original owner.

The warranty holder is responsible for the performance of the required maintenance as defined by the manufacturer's owner's manuals. The warranty holder is responsible for replacement of normally wearing parts such as the Drive Belt, Knife, Wear Plate, Clutch Drive, Flex Guards, Filters, and Spark Plug. Attachments and accessories to the machine are not covered by this warranty.

During the warranty period, the warranty holder is responsible for the machine transportation charges, if required. During the warranty period, warranty parts will be shipped by standard method at no charge to the warranty holder. Expedited shipping of warranty parts is the responsibility of the warranty holder.

SOME STATES DO NOT ALLOW LIMITATIONS ON THE LENGTH OF IMPLIED WARRANTIES, SO THE ABOVE LIMITATIONS MAY NOT APPLY TO YOU.

Country Home Products, Inc. shall not be liable under any circumstances for any **incidental or consequential damages or expenses** of any kind, including, but not limited to, cost of equipment rentals, loss of profit, or cost of hiring services to perform tasks normally performed by the DR[®] RANGER CHIPPER.

SOME STATES DO NOT ALLOW THE EXCLUSION OR LIMITATION OF INCIDENTAL OR CONSEQUENTIAL DAMAGES, SO THE ABOVE LIMITATIONS MAY NOT APPLY TO YOU.

Customer Service Hotline

Country Home Products, Inc.'s objective is to have 100% satisfied customers. For that reason, we operate a 6-day-a-week Technical Service Department for our Owners. You can access a Representative by dialing our TOLL-FREE Hotline at **1-800-DR-OWNER (376-9637)**. The sole job of our well-trained and friendly folks is to ensure that you get any help you need in a timely fashion. They are there to answer all your questions including: (1) inquiries on any of the above warranties, (2) inquiries about replacement parts, or (3) your questions regarding service, maintenance, and operation.

Our Customer Service Representatives will also be happy to answer any of your questions regarding the separate warranties on all engines. However, to obtain service, repair or replacement of any engine within the time period covered by the manufacturer's limited warranty, follow the instructions and warranty information specifically pertaining to those items provided by their separate manufacturers.

THIS WARRANTY GIVES YOU SPECIFIC LEGAL RIGHTS, AND YOU HAVE OTHER RIGHTS, WHICH VARY FROM STATE TO STATE.

Daily Checklist for the DR RANGER CHIPPER

To help maintain your DR RANGER CHIPPER for optimum performance, we recommend you follow this checklist each time you use your machine.

- [] OIL: With the machine on a level surface, check the Engine oil level and add more if necessary. Use SAE 30 high detergent motor oil.
- [] GAS: Fill the Gas Tank with clean, fresh, unleaded gasoline.
- [] ENGINE AIR COOLING SYSTEM: It is very important to keep the Engine clean of debris. Remove grass and other built-up materials from the Air Intake Screen before, during, and after you chip. Regularly remove debris from the Blower Housing and Cooling Fins. A dirty Engine retains heat and can cause damage to the internal Engine parts.
- [] CHIPPER HOPPER: Inspect the Chipper Hopper for accumulated debris.
- [] KNIFE: Inspect the Chipper Knife for tightness, nicks and wear.
- [] WEAR PLATE: Check the Wear Plate for nicks; the edge should be square.
- [] BELT: Check the condition of the Drive Belt for nicks and cuts.
- [] GENERAL CONDITION: Check the general condition of the machine, e.g.; Nuts, Bolts, and Welds etc.



COUNTRY HOME PRODUCTS, Inc.

MEIGS ROAD, P.O. BOX 25, VERGENNES, VERMONT 05491

1-800-DR-OWNER (376-9637) • www.dr-owner.com

©2006 CHP, Inc. 225841