

DR[®] DUAL-ACTION LOG SPLITTER

Electric to Gas Conversion Kit# 295161



These instructions will aid in the Electric to Gas conversion for your Dual-Action Log Splitter. Please keep these instructions with your Log Splitter Safety and Operating Manual for future reference.

Tools and Supplies Needed:

- 19mm Wrench
- 7/8" Wrench
- Two 7/16" Wrenches
- Two 1/2" Wrenches
- Clean Container (for Hydraulic Fluid)

WARNING

Before performing any maintenance procedure or inspection, stop the Motor, unplug the cord from the outlet and wait five (5) minutes to allow all parts to cool.

1. Relieve any pressure in the system by cycling the Operator Lever back forth a few times.
2. Place the Clean Container under the Hydraulic Pump (**Figure 1**).

Note: The elbows will be left on the Pump. Only disconnect the Hoses in the following instructions.

3. Disconnect the Pressure Hose at the Elbow with a 19mm Wrench.
4. Disconnect the intake Hose at the Elbow with a 7/8" Wrench and support the hose end so it stays above the Tank to prevent leaking.
5. Remove the four Bolts, Washers and Locknuts from the Motor Mount with two 1/2" Wrenches and remove the Motor with Pump (**Figure 2**).

Note: The Motor was mounted using the four round holes on the mount, but the Engine will use the four slotted holes.

6. Position the Engine with Pump onto the Frame Mount and secure with the new Bolts, Washers (one Washer on Bolt side and one on Locknut side) and Locknuts using two 1/2" Wrenches (**Figure 3**).

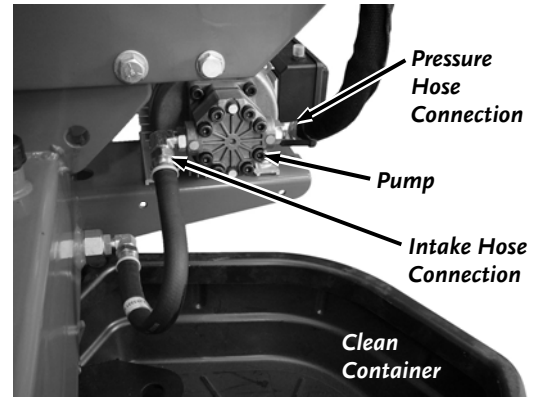

Figure 1

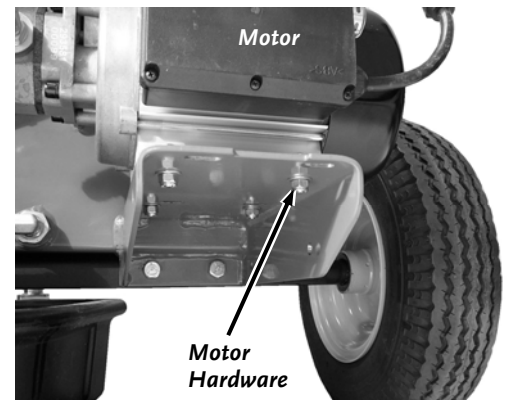

Figure 2

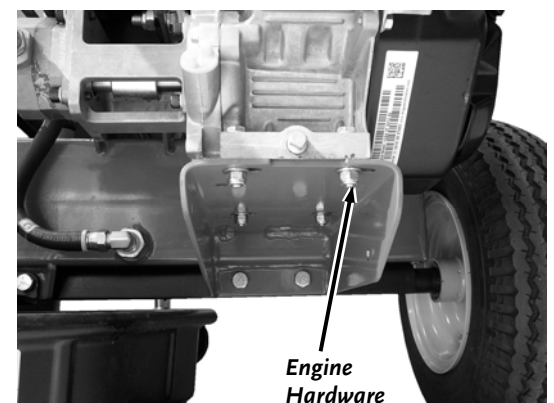

Figure 3

Continued on
other side



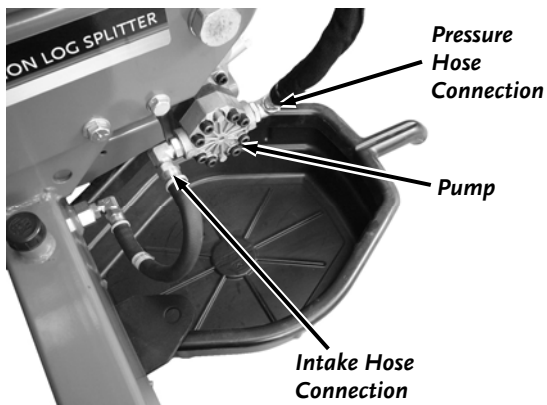

Figure 4

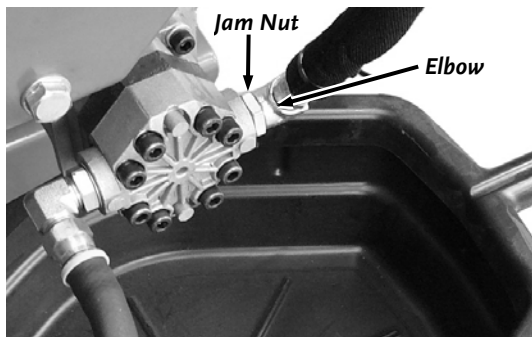

Figure 5

7. Remove the plastic protectors from the Pump Elbow threads.

Note: The angle of the Elbows is set at the factory and should be at the correct position to connect the Hydraulic Hoses. If however you are unable to connect a Hose to the Elbow, due to the angle, an adjustment is required. Go to "Elbow adjustment" at the end of this document. If the Hoses will connect with no adjustment, continue to the next step.

8. Connect the intake Hose at the Intake Elbow with a 7/8" Wrench (**Figure 4**).

9. Connect the Pressure Hose at the Elbow with a 19mm Wrench.

Refer to your new Dual-Action Gas Log Splitter Safety and Operating Instruction manual to cycle and check fluid level before continuing with the Operating section of the manual.

If you have any questions please contact us at www.DRpower.com or call 1-800-DR-OWNER (376-9637) for assistance.

Elbow Adjustment (Only perform if the Hose will not reach the Elbow due to Elbow angle)

These adjustments work for both elbows on the Pump.

Tools and Needed:

- 24mm Wrench

1. Loosen the Jam Nut with a 24mm Wrench and back it off until it stops (**Figure 5**).
2. Screw the Elbow into the Pump all the way so the Washer is against the Elbow and Pump.

3. Turn the Elbow back to the angle needed to attach the Hose.

Note: Do not turn the Elbow back more than one full turn when adjusting.

4. Tighten the jam nut against the Pump and return to step 8 of the kit installation above.

