

# ***DR CHIPPER***

## ***Operating & Assembly Instructions***

---

***Model: Tractor Attachment Chipper***

***TPH-CHP***

This manual contains information concerning proper and improper operating procedures, warnings, maintenance, troubleshooting, assembly, and tips. Everyone who operates this machine should read these instructions and be thoroughly familiar with them.

---

## SECTION I – SAFETY

---



**This symbol points out important safety instructions**, which, if not followed, could endanger the personal safety and/or property of yourself and others. Read and follow all instructions in this manual before attempting to operate your chipper. Failure to comply with these instructions may result in personal injury. When you see this symbol - **heed its warning**.

**THIS MACHINE IS CAPABLE OF INFLICTING SERIOUS INJURY  
IF  
OPERATED IMPROPERLY -- READ WARNINGS & CAUTION LABELS.**

### INTENDED USE

**Never** use your chipper for any other purpose than chipping limbs. It is designed for this use and any other use may cause serious injury.



**DANGER:** *Rotating cutting blade.*

Keep hands and feet out of inlet and discharge opening while machine is running.

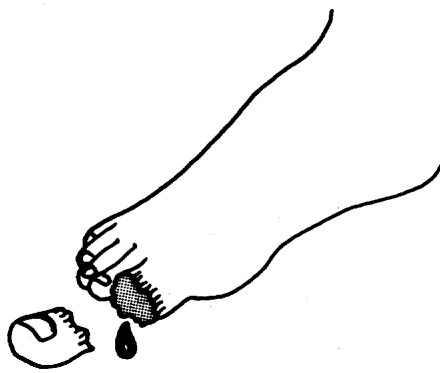
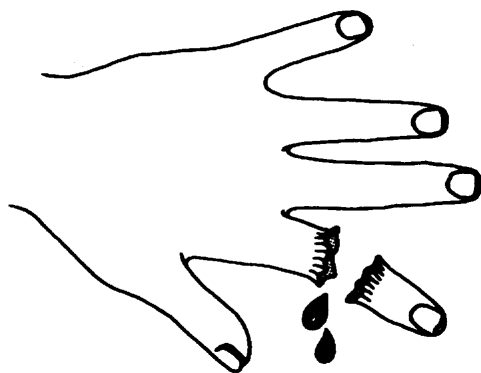

**DANGER:** This machine can **CRUSH, GRIND, CUT,** and **SEVER** parts of your body if they enter the inlet or discharge area of your chipper.



**DANGER:** Your chipper was built to be operated according to the rules for safe operation in this manual. **As with any type of power equipment, carelessness or error on the part of the operator can result in serious injury.** If you violate any of these rules, you may cause serious injury to yourself or others.

**MAKE CERTAIN THAT ALL SAFETY LABELS ON THIS EQUIPMENT ARE KEPT CLEAN AND IN GOOD CONDITION. IF YOU NEED REPLACEMENT LABELS, ORDER BY PART NUMBER.**



080-0967



080-0970



091-0055



091-0059

**MADE IN  
U.S.A.**

091-0062



091-0088



091-0380



091-0057



091-0381

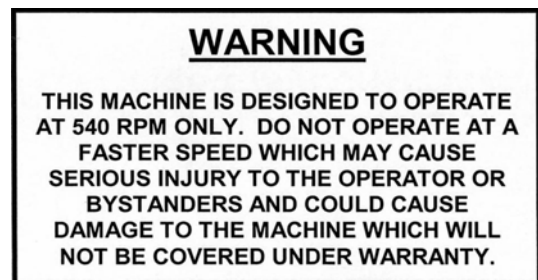

091-0385

# **SAFE OPERATION PRACTICES**

## **TRAINING**

- Read this owner's manual carefully in its entirety before attempting to assemble this machine. Read, understand, and follow all instructions on the machine before operation. Be completely familiar with the controls and the proper use of the machine before operating it. Keep this manual in a safe place for future and regular reference and for ordering replacement parts.
- Know how to stop the unit and disengage the controls quickly.
- Never allow children to operate the unit. Never allow adults to operate the equipment without proper instruction. Only responsible individuals who are familiar with these rules of safe operation should be allowed to use your unit.
- Keep the area of operation clear of all persons, particularly small children and pets. Stop the engine when they are in the vicinity of the unit. Keep work area clean and clear of branches or obstacles, which could cause you to stumble or fall.
- Keep in mind that the operator or user is responsible for accidents or hazards occurring to other people, their property, and themselves.
- Your chipper is a powerful tool, not a plaything. Exercise extreme caution at all times. Your unit has been designed to chip limbs and branches. Do not use it for any other purpose.
- If situations occur which are not covered in this manual, use care and good judgment. Contact your place of purchase for additional assistance.

## **PREPARATION**

- Thoroughly inspect the area where the equipment is to be used and remove all foreign objects.
- Do not operate the machine without wearing adequate outer garments and safety goggles. Always wear safety glasses or goggles during operation and while performing any adjustment or repair, to protect eyes from foreign objects that may be thrown from the machine. Be sure your glasses or goggles fit properly.
- Avoid loose-fitting clothes and use protective footwear that will improve footing on slippery surfaces. Shirt and slacks that cover the arms and legs and steel-toed shoes are recommended. Secure hair above shoulders. Do not wear loose clothes or jewelry that can be caught in moving parts. Never operate a unit in bare feet, sandals or sneakers. Wear gloves when feeding material into the shredder hopper or chipper chute. Be sure your gloves fit properly and do not have loose cuffs or drawstring.
- Never attempt to make any adjustments without shutting off the tractor and disengaging the P.T.O. drive shaft.

## **OPERATION**

- Never place your hands, feet, or any part of your body in the chipper chute or discharge opening, or near or under any moving part while the chipper is running. Keep clear of the discharge opening at all times. If it becomes necessary to push material into the chipper chute, use a small diameter stick, NOT YOUR HANDS.
- Keep your face and body back from the chipper chute to avoid accidental bounce back of any material.
- The chipper is designed to be run with the weight of the unit on the ground. Chipping with the unit while it is off the ground can result in injury to yourself or others, or damage to the machine which may not be covered under warranty.
- The machine should only be operated on a level surface. Never operate your unit on a slippery, wet, muddy, or icy surface.
- Exercise caution to avoid slipping or falling.
- Stay alert for hidden hazards or traffic. Do not carry passengers.
- If the cutting mechanism strikes a foreign object or if your machine should start making an unusual noise or vibration, immediately stop the tractor and wait for all moving parts to come to a complete stop. After the machine has come to a complete stop proceed as follows:
  - Inspect for any damage.
  - Repair or replace any damaged parts before restarting and operating the machine.
- If the machine should start to vibrate abnormally, immediately stop the tractor and wait for all moving parts to come to a complete stop and inspect for the cause. Vibration is generally a warning sign of trouble.

- Disengage the P.T.O. drive shaft when leaving the operating position.
- Disengage the P.T.O. when moving the chipper.
- Stop the tractor and disconnect the P.T.O. drive shaft when making any repairs, adjustments and inspections.
- Take all possible precautions as recommended by the manufacturer when leaving the machine unattended. Stop the tractor and remove the key if so equipped.
- Before cleaning, repairing, or inspecting, shut off the tractor and make certain the flywheel and all moving parts have come to a complete stop.
- Never run this machine in an enclosed area as the exhaust from the tractor engine contains carbon monoxide, which is an odorless, tasteless, and deadly poisonous gas.
- Keep all guards and safety devices in place and operating properly. Do not operate the machine if all safety guards are not in place.
- Do not use the unit with the chipper hopper removed.
- Keep children and pets away.
  - Tragic accidents can occur if the operator is not alert to the presence of small children.
  - Keep children out of the work area and under the watchful eye of a responsible adult other than the operator.
  - Be alert and turn the unit off if a child enters the area.
  - Never allow children to operate the chipper.
- Do not overload or attempt to chip material beyond manufacturers recommendation. Personal injury or damage to the machine could result.
- Never operate the machine at high transport speeds or on hard or slippery surfaces.
- Never allow bystanders near the unit while running.
- Only use accessories approved for this machine by the manufacturer. Read, understand, and follow all the instructions provided with the approved accessory.
- Only operate unit in good daylight. Do not operate unit at night or in dark areas where your vision may be impaired.
- Use extreme caution when reversing or pulling the machine towards you.
- This machine is designed to operate at 540 RPM only. Do not operate at a faster speed, which may cause serious injury to the operator or bystanders and could cause damage to the machine that will not be covered under warranty.
- Never pick up or transport the machine while the P.T.O. drive shaft is engaged.
- Do not operate while under the use of alcohol, drugs, or medication. A clear mind is essential for safety.
- Do not allow anyone who is not alert to operate this machine.
- When feeding material into this equipment, be extremely careful that pieces of metal, rocks, or other foreign objects are not included. Personal injury or damage to the machine could result.
- Keep area of discharge clear of people, animals, buildings, glass or anything else that will obstruct clear discharge, cause injury or damage. Wind can also change discharge direction, so be aware.
- Do not allow an accumulation of processed material to build up in the discharge area as this will prevent proper discharge and can result in kickback from the chipper chute.

## **MAINTENANCE AND STORAGE**

- Keep machine, attachments and accessories in safe working condition.
- Check hardware at frequent intervals for proper tightness. Never operate your chipper in poor mechanical condition or when in need of repair. Be sure all safety guards and shields are in proper position. These safety devices are for your protection.
- Always refer to the operator's manual for important details if the machine is to be stored for an extended period.
- Follow the manufacturer's recommendations for safe loading, unloading and storage of machine.
- If it is necessary for any reason to unclog the feed intake or discharge openings or to inspect or repair the machine where a moving part can come in contact with your body or clothing, shut the tractor off and allow all moving parts to come to a complete stop before attempting to unclog, inspect or repair.
- Check the knife mounting screws at frequent intervals for proper tightness. Also visually inspect the knife for wear or damage. Replace the knife with parts that meet original equipment specifications.
- Knives should be checked for sharpness and the bolts attaching them to the flywheel for tightness every 8-10 hours of operation.
- Replace the nylock nuts securing the knife every time you replace the knife.
- Check the gap between the knife and wear plate every time you sharpen or replace the knife, or every 8-10 hours of operation.
- Never tamper with safety devices. Check their proper operation regularly.
- Inspect the belt each time you use the unit. Look for damage, worn areas or tears. Do not use the unit if this condition exists.
- This machine is designed to operate at 540 RPM only. Do not operate at a faster speed that may cause serious injury to the operator or bystanders and could cause damage to the machine that will not be covered under warranty.

## SECTION II - ASSEMBLY & INSTALLATION

### PACKAGE CONTENTS

SKID	PARTS BOX	BOLT BAG
CHIPPER	PTO DRIVE SHAFT	1 EA – UPPER SPACER – 1 625"
PARTS BOX	CHIPPER HOPPER	2 EA – LOWER SPACER – 1.6"
	DEFLECTOR	1 EA – UPPER MOUNT PIN
	OWNER'S MANUAL	4 EA – 3/16" HAIR PIN
	WARRANTY CARD	1 EA – ¼" X ¼" X 1 ½" KEY
	SAFETY GLASSES	4 EA – 5/16-18 X ¾" CARRIAGE BOLT
	BOLT BAG	8 EA – 5/16 FLAT WASHERS
	KNIFE GAUGE	6 EA – 5/16-18 NYLOCK NUT
		2 EA – 3/8-16 X 3/8" SET SCREW
		2 EA – 5/16-18 X 4" HHCS

### TOOLS REQUIRED FOR ASSEMBLY & INSTALLATION

- ½" Wrench or socket

### ASSEMBLY

#### STEP I – UNPACKING AND CHECKING CONTENTS

- Remove the all items from the crate.
- After unpacking the crate, compare the contents with the list above.
- If any parts are missing, contact Country Home Products at 800-376-9637.
- Assembly should be done on a clean, level surface.

#### STEP II – ASSEMBLING THE CHIPPER HOPPER

- Assemble chipper hopper (item #36, pg 20) to the basic machine (item #29, pg 20) using four each 5/16"-18 x ¾" carriage bolts, 5/16"-18 nylock nuts and 5/16" flatwashers from the bolt bag. Put head of bolt inside hopper with threads sticking out. Tighten all hardware with a ½" wrench.

#### STEP III – ATTACHING THE DEFLECTOR

- Hold the deflector (item #37, pg 21) in place at the discharge opening of the basic machine (item #29, pg 20).
- Put a 5/16" flatwasher on a 5/16-18 x 4" HHCS from the bolt bag and attach to the basic machine.
- Add a 5/16" flatwasher to the other side of the bolt and secure with a 5/16-18 nylock nut.
- Repeat at bottom hole of the deflector.
- Pull up on end of deflector while tightening hardware.

**NOTE: Be certain that the bolts attaching the deflector to the basic machine go through the pipes that are welded to the scroll (item #14, pg 22).**

### INSTALLATION

- Many category 0 tractors permit direct mounting to the lower support pins on the frame of the chipper. If the lower hitch arms on your tractor do not have enough inward adjustment to attach to the lower support pins, a pair of pin extensions may be required to allow proper mounting of the chipper to the tractor.
- The bushings included, one upper (item #26, pg 19) and two lower (item #27, pg 19), should be used on the upper and lower mount pins of the chipper if attaching the unit to a category 1 tractor.
- The P.T.O. driveshaft provided with this machine is sized to fit a standard category 1 P.T.O. (1 3/8" x 6 spline).
- The P.T.O. shaft on the tractor that is to use this chipper **must rotate clockwise** when viewing the P.T.O. from the rear of the tractor. If the P.T.O. rotates counterclockwise, you must have your tractor modified by installing a gear box to reverse the direction of rotation.
- Depending on the mounting dimensions of the tractor, it may be necessary to have your dealer or yourself modify the length of the P.T.O. driveshaft that is included with this chipper. Instructions follow for this procedure.
- **The ¼" x ¼" x 1 ½" key in the bolt bag must be installed where the P.T.O. shaft attaches to the chipper. Failure to do so will result in damage to the chipper that will not be covered under warranty.**



The P.T.O. driveshaft included with this chipper may be too long for your tractor. To shorten the driveshaft proceed as follows.

- Remove the guard.

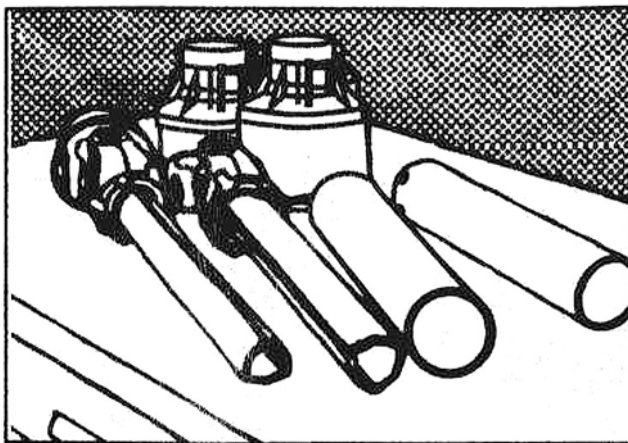

- Cut the shaft tubes to the required length.

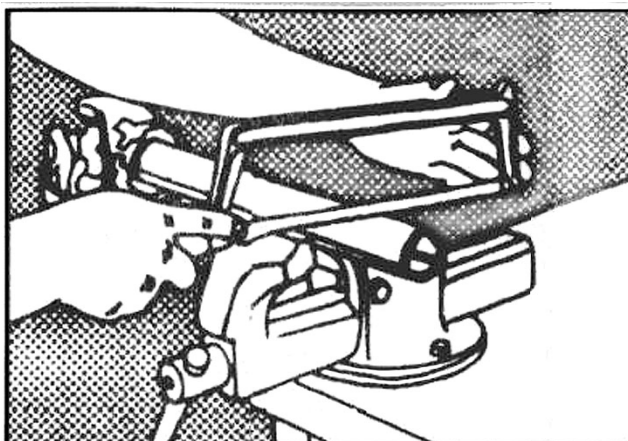

- Round off all edges.

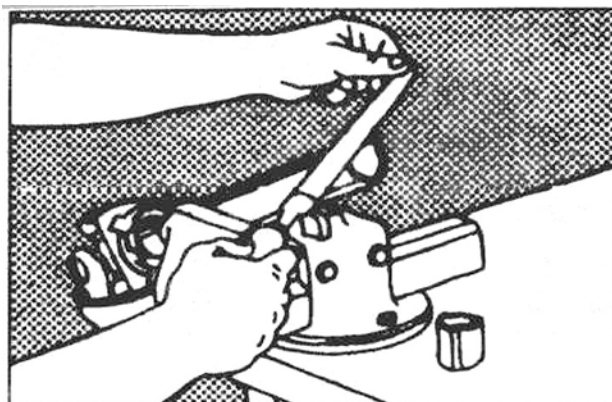

- Shorten the guard tubes to the same length.

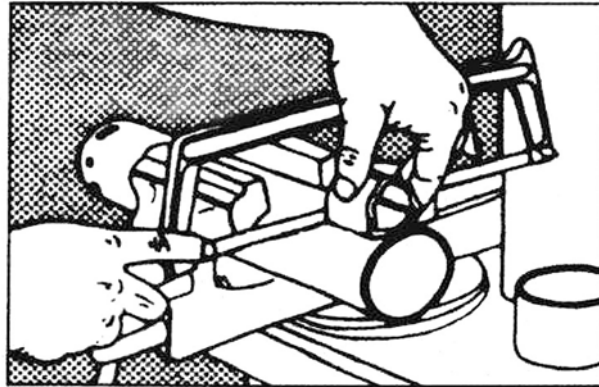

- Grease the shaft tubes and reassemble.

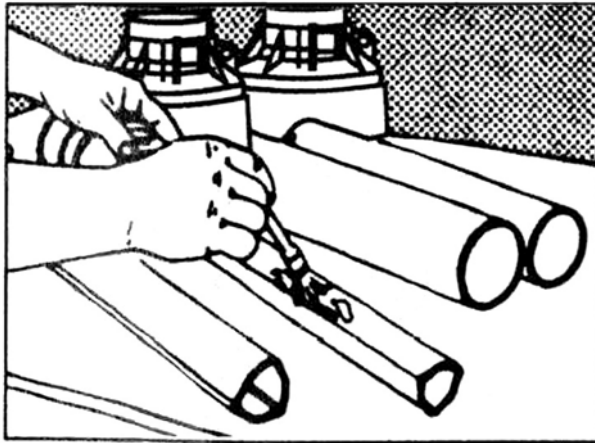

**REFER TO THE BROCHURE THAT COMES WITH THE P.T.O. DRIVE SHAFT FOR  
ADDITIONAL DRIVE SHAFT INFORMATION.**

---

## SECTION III - OPERATION

---

**THIS TRACTOR CHIPPER ATTACHMENT HAS BEEN DESIGNED TO OPERATE ON BOTH CATEGORY 0 AND CATEGORY 1 TRACTORS.**

**THIS MACHINE IS DESIGNED TO OPERATE AT 540 RPM ONLY!**  
**DO NOT OPERATE AT A FASTER SPEED. THIS CAN CAUSE SERIOUS INJURY TO THE OPERATOR OR BYSTANDERS AND COULD CAUSE DAMAGE TO THE MACHINE THAT WILL NOT BE COVERED UNDER WARRANTY.**

**THE CHIPPER IS DESIGNED TO BE RUN WITH THE WEIGHT OF THE UNIT ON LEVEL GROUND. CHIPPING WITH THE UNIT OFF THE GROUND OR ON UNEVEN GROUND CAN RESULT IN INJURY TO YOURSELF OR OTHERS OR UNSATISFACTORY PERFORMANCE.**

### **Operation Notes**

- To activate the chipper, engage the P.T.O. with the tractor running at idle. Gradually increase engine speed until you achieve a P.T.O. speed of 540 RPM.
- Proper rotor speed is 2200 RPM +/- 200 RPM.
- When viewed from the operator zone, the flywheel turns in a clockwise direction. This rotation pulls branches into the chipper.
- Always wear protective gloves and safety glasses during operation of the chipper.
- If it becomes necessary to push material into the chipper hopper, only use a wood stick, never your hands or anything steel.
- Never assume you know where the knife is. You don't know where it is. Always keep hands out of all feed hoppers.
- Keep area of discharge clear of people, animals, buildings, glass or anything else that will obstruct clear discharge, cause injury or damage.
- If the cutting mechanism strikes a foreign object or if your machine should start making an unusual noise or vibration, immediately stop the tractor and wait for all moving parts to come to a complete stop. After the machine has come to a complete stop proceed as follows:
  - Inspect for any damage.
  - Repair or replace any damaged parts before restarting and operating the machine.
- If the machine should start to vibrate abnormally, immediately stop the tractor and wait for all moving parts to come to a complete stop and inspect for the cause. Vibration is generally a warning sign of trouble.
- Disengage the P.T.O. drive shaft when leaving the operating position.
- Disengage the P.T.O. when moving the chipper.
- When feeding material into this equipment, be extremely careful that pieces of metal, rocks, or other foreign objects are not included. Personal injury or damage to the machine could result.

---

## **SECTION IV – CHIPPING**

---

**THIS CHIPPER WAS DESIGNED FOR CHIPPING LIMBS OR BRANCHES. NEVER USE THIS MACHINE FOR ANY OTHER PURPOSE AS IT COULD CAUSE SERIOUS INJURY.**

**CONTACT WITH INTERNAL ROTATING PARTS WILL CAUSE SERIOUS PERSONAL INJURY. DO NOT PUT HANDS, FACE, FEET OR CLOTHING INTO CHIPPER CHUTE OR DISCHARGE OPENING OR NEAR THE DISCHARGE AREA AT ANY TIME.**

**MAINTENANCE AND SERVICE SHOULD ONLY BE PERFORMED AFTER THE TRACTOR ENGINE IS OFF, THE P.T.O. DRIVE SHAFT IS DISCONNECTED, AND ALL MOVING PARTS HAVE COME TO A COMPLETE STOP. USE ONLY A WOODEN STICK TO CLEAR JAMMED MATERIAL AFTER ALL MOVING PARTS HAVE STOPPED COMPLETELY.**

### **SAFETY FIRST**

- Always wear protective gloves and safety glasses during operation of the chipper.
- Never allow your hands or any part of your body or clothing inside the chipper hopper or discharge area of the chipper.
- Keep all protective guards and warning labels on the machine and in good working condition.
- Always stand clear of the discharge area when the chipper is running.
- Keep your face and body back from the chipper hopper to avoid being struck by any material that may bounce back.
- Keep proper balance and footing while operating the chipper.
- If it becomes necessary to push material into the chipper hopper, only use a wood stick, never your hands or anything steel.
- Never assume you know where the chipper knife is. You do not know where it is.
- Keep area of discharge clear of people, animals, buildings, glass or anything else that will obstruct clear discharge, cause injury or damage. Wind can also change discharge direction, so be aware.
- Always keep hands out of the chipper hopper.
- Never operate the chipper without the chipper hopper in place.
- Do not transport the chipper while it is running.

### **PROCESSING LIMBS OR BRANCHES**

- Your chipper can process dry or green material.
- Remove side limbs, branches or twigs from main branch.
- Feed branch into chipper hopper.
- Keep branch at same angle as chipper hopper.
- As the branch becomes short and is inside the chipper hopper, finish processing it by pushing it into the chipper with the next branch.
- If branches are 2" or larger in diameter, feed only one branch at a time into the chipper.
- If branches are smaller than 2", more than one at a time can be fed into the chipper.
- Green branches process quicker and easier than dry branches.
- Soft wood processes easier than hard wood.

- When chipping branches, sometimes a tail will be left at the end of the branch (usually green wood) that will increase in length as you chip. To avoid this, rotate or twist the branch as you feed it into the chute.
- Rotating the branch as you feed it into the machine will improve chipping performance.
  
- **USE COMMON SENSE WHEN USING YOUR CHIPPER.**
  
- **LEARN TO RECOGNIZE THE CHANGE IN THE SOUND OF YOUR MACHINE WHEN IT IS OVERLOADED.**
  
- **BECOME FAMILIAR WITH SUCCESSFUL OPERATING CONDITIONS AND AVOID THOSE THAT CAN OVERLOAD AND DAMAGE THE MACHINE.**
  
- **IF THE MACHINE BECOMES JAMMED BY OVERLOADING OR ANY OTHER CAUSE, STOP THE MACHINE IMMEDIATELY.**
  
- **IF YOU JAM THE MACHINE AND DO NOT DISENGAGE THE P.T.O., IT CAN DAMAGE THE MACHINE. THIS DAMAGE CAN BE COSTLY AND IT MAY NOT BE COVERED UNDER WARRANTY. FOR THIS REASON, IT IS IMPORTANT THAT YOU IMMEDIATELY STOP THE TRACTOR AND DISENGAGE THE P.T.O. IF THE MACHINE BECOMES JAMMED.**
  
- **ONLY YOUR OPERATOR EXPERIENCE WILL TELL YOU HOW FAST TO FEED LIMBS.**
  
- **CHECK TO SEE THAT THE FLYWHEEL WILL TURN FREELY BEFORE YOU START THE CHIPPER.**
  
- **VISUALLY CHECK CHIPPER KNIFE FOR DAMAGE EACH TIME YOU USE YOUR CHIPPER.**
  
- **CHECK KNIFE CONDITION, WEAR PLATE CONDITION, GAP SETTING AND THE NUTS AND BOLTS THAT HOLD THE KNIFE IN PLACE FOR TIGHTNESS EVERY 8-10 HOURS OF OPERATION.**
  
- **DO NOT ALLOW CHIPS TO BUILD UP WITHIN 3” OF DISCHARGE CHUTE OPENING. MOVE CHIPPER OR PILE AS NEEDED. FAILURE TO DO THIS COULD RESULT IN UNNECESSARY JAMMING OF THE MACHINE.**
  
- **TO MOVE PILE OF PROCESSED MATERIAL, USE SPADE, RAKE, OR LONG HANDLE TOOL. NEVER USE YOUR HANDS OR FEET!**

## TO FREE A JAMMED FLYWHEEL

- Stop the tractor engine and disengage the P.T.O. shaft.
- Remove any material left in the chipper hopper.
- Remove the deflector.

**NOTE: Never pry against the scroll weldment when removing the deflector or at any other time. This will cause damage to the machine.**

- Check to see if deflector is clogged. If it is, clear with a branch.
- With a wooden stick, loosen and remove any material left in the chipping chamber.
- Reinstall the deflector.
- Reconnect the P.T.O. shaft.
- Start machine and let material in chipping chamber discharge through deflector.
- If chamber doesn't clear and the flywheel is still jammed, repeat above process.
- Be certain chipping chamber is clear before trying to process more material into the chipper.

---

## SECTION V - MAINTENANCE AND STORAGE

---

**IMPORTANT:** The knife should be checked for sharpness and the nuts and bolts attaching it to the flywheel for tightness every 8-10 hours of operation.

**IMPORTANT:** Every time you perform maintenance or any kind of service or check on the knife, be sure to check the gap between the knife and wear plate for proper setting.

**NOTE:** A knife gauge has been provided with your machine. It is 1/16<sup>th</sup> thick and should be used to set the correct gap between the knife and wear plate.

If the cutting mechanism strikes any foreign object or if your machine should start making an unusual noise or is vibrating, stop the engine, disconnect the spark plug wire from the spark plug. Allow the engine to cool before you;

- a. Inspect and examine for obvious damage.
- b. Check for loose parts, bolts, and nuts.

1. When not in use, your chipper should be stored out of the reach of children.
2. After every 8 hours of operation, lubricate the chipper side and drive side bearings with multi-purpose lithium grease. Also, check the bearing collar set screws regularly to be sure they are tight. If they are loose, reset them with Loctite 243, obtainable at any hardware store.
3. When the steel chipping knife (item #11, pg. 22) needs replacing or sharpening, refer to the section on removal, sharpening and re-installation.
4. Care must be exercised when sharpening the knife to maintain the correct bevel and a straight edge. Refer to sharpening directions. When you install a knife, the clearance between the knife and wear plate must be checked and set. This clearance or gap should be set to 1/16" (see figure 1).
5. To adjust this clearance, loosen the three 1/4" nuts and bolts (item #16 & #22, pg. 22) holding the wear plate in place. The wear plate can be slid up or down (in or out) to achieve the correct gap setting.
- 6.
7. Take the knife gauge and slide between the knife and wear plate. If the gap is set correctly, the knife gauge will lightly touch both the knife and wear plate. If the gap is too small, you will not be able to get the gauge between the knife and wear plate. If the gap is too large, there will be excess room between knife gauge, knife and wear plate. Tighten the nuts and bolts when the wear plate is in the correct position. Be certain the flywheel rotates without hitting anything before starting the chipper.
8. If the gap between the wear plate and the knife is not set correctly, you will have excessive vibration when chipping and the blade will seem to be dull. This should be checked every 8-10 hours of operation.
9. If at any time it becomes necessary to disassemble the chipper for repairs, the chipper disk (item #13, pg. 22) must be re-installed in exactly the same position on the rotor shaft.

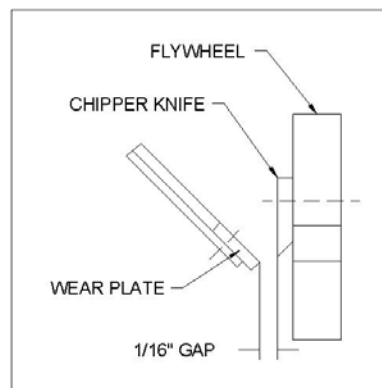

**NOTE:** Proper gap setting is critical to the proper operation of your machine.

## REMOVAL, SHARPENING AND RE-INSTALLATION OF CHIPPER KNIFE

### HOW TO REMOVE THE KNIFE

- Stop the tractor and disengage the P.T.O. shaft.
- Remove both access covers from the chipper basic machine.
- Rotate the chipper disk until the three countersunk screws and nylock nuts attaching the knife to the flywheel are visible through the access doors.
- Clean out the heads of the allen screws with an awl or sharp tool.
- Insert a 3/16" allen wrench into the heads of the screws.
- Use a 1/2" socket and ratchet to remove the nylock nuts from the screws.
- Remove all three allen screws and nuts in this manner.

### KNIFE SHARPENING

- You should never attempt to sharpen the chipper knife freehand.
- The chipper knife should be taken to a machine shop for proper sharpening.
- It is extremely important that the 45 degree angle be maintained consistently for proper performance.
- Excessive heat generated during the sharpening process will damage knives and weaken the metal. Be sure the knife is not overheated.

### KNIFE INFORMATION

- The chipper knife should be checked routinely for sharpness.
- Using a dull knife will decrease performance and cause excessive vibration that will cause damage to the chipper.
- How many times a knife can be sharpened is determined by how much material needs to be taken off to sharpen or to compensate for dents or gouges.
- A new chipper knife has 5/16" measurement between the short side bevel edge and the knife mounting holes. See figure 2.

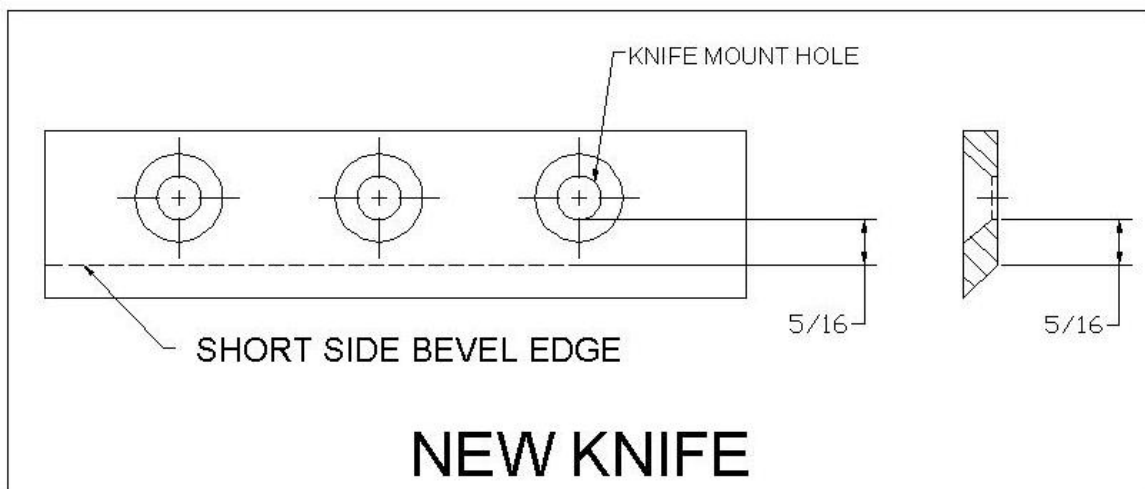

Figure 2



- The knife should never be sharpened to the extent that more than 3/32" is taken off this measurement.
- Once this measurement is below 7/32" (see figure 3) the knife should be replaced.
- If you are unable to remove dents or gouges with these guidelines, replace the knife.

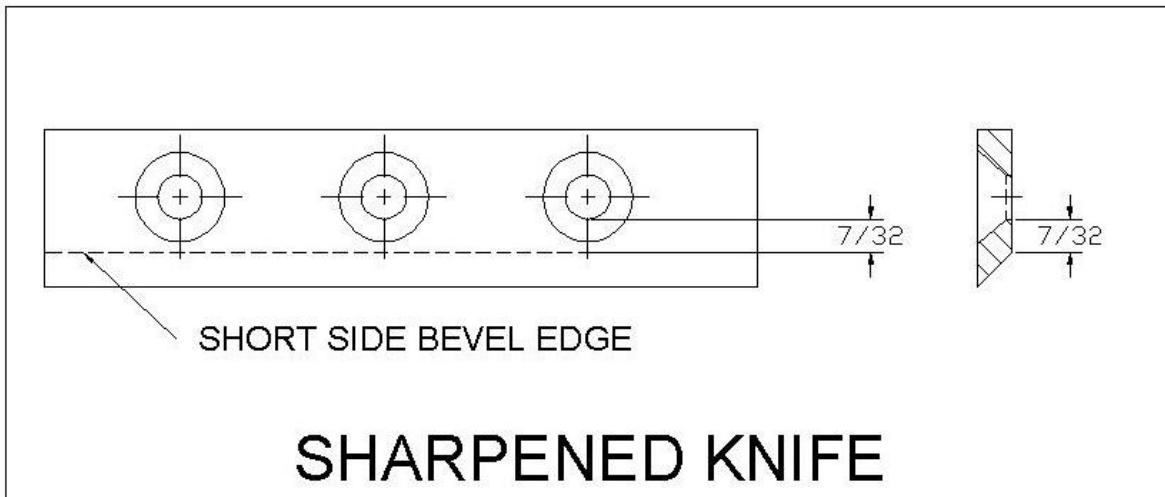

Figure 3

### KNIFE INSTALLATION

- Clean chipper disk where knife is going to be attached.
- Visually inspect the chipper disk slot and knife mounting area and be sure they are clean and that the knife will be able to mount flush against the chipper disk.
- Visually inspect and clean the knife.
- Hand tighten the knife to the chipper disk with bolts and nylock locking nuts. If you are installing a new knife, use the new hardware that comes with the knife when attaching it to the chipper disk.
- Tighten the center nut and bolt.
- Tighten the outer nut and bolt.
- Tighten the inner nut and bolt.
- Double check all three for tightness one more time.

### WEAR PLATE

- The wear plate should have a square edge and be free of dents or gouges.
- The wear plate can be sharpened by hand, but as with the knife, do not overheat during the sharpening process. This will change the characteristics of the steel and it should be replaced.
- Check the gap between the knife and wear plate every time any adjustments are done to either piece, or every 8-10 hours of operation.

**AFTER ANY BLADE OR WEAR PLATE MAINTENANCE OR ADJUSTMENT, ROTATE THE CHIPPER DISK BY HAND. WATCH AND LISTEN CAREFULLY FOR ANY UNUSUAL NOISES, CLICKING OR VIBRATION. IF ANY OF THESE ARE DETECTED, INSPECT THE MACHINE FOR DAMAGE, REPAIR OR REPLACE ANY DAMAGED PARTS AND CHECK FOR ANY LOOSE PARTS AND RETIGHTEN.**

**KNIVES MUST BE CHECKED AND MAINTAINED!**

**KNIVES MUST BE SHARP!**

**BE SURE TO REINSTALL THE KNIFE CORRECTLY AND DOUBLE CHECK FOR TIGHTNESS!**

SECTION VI - PARTS

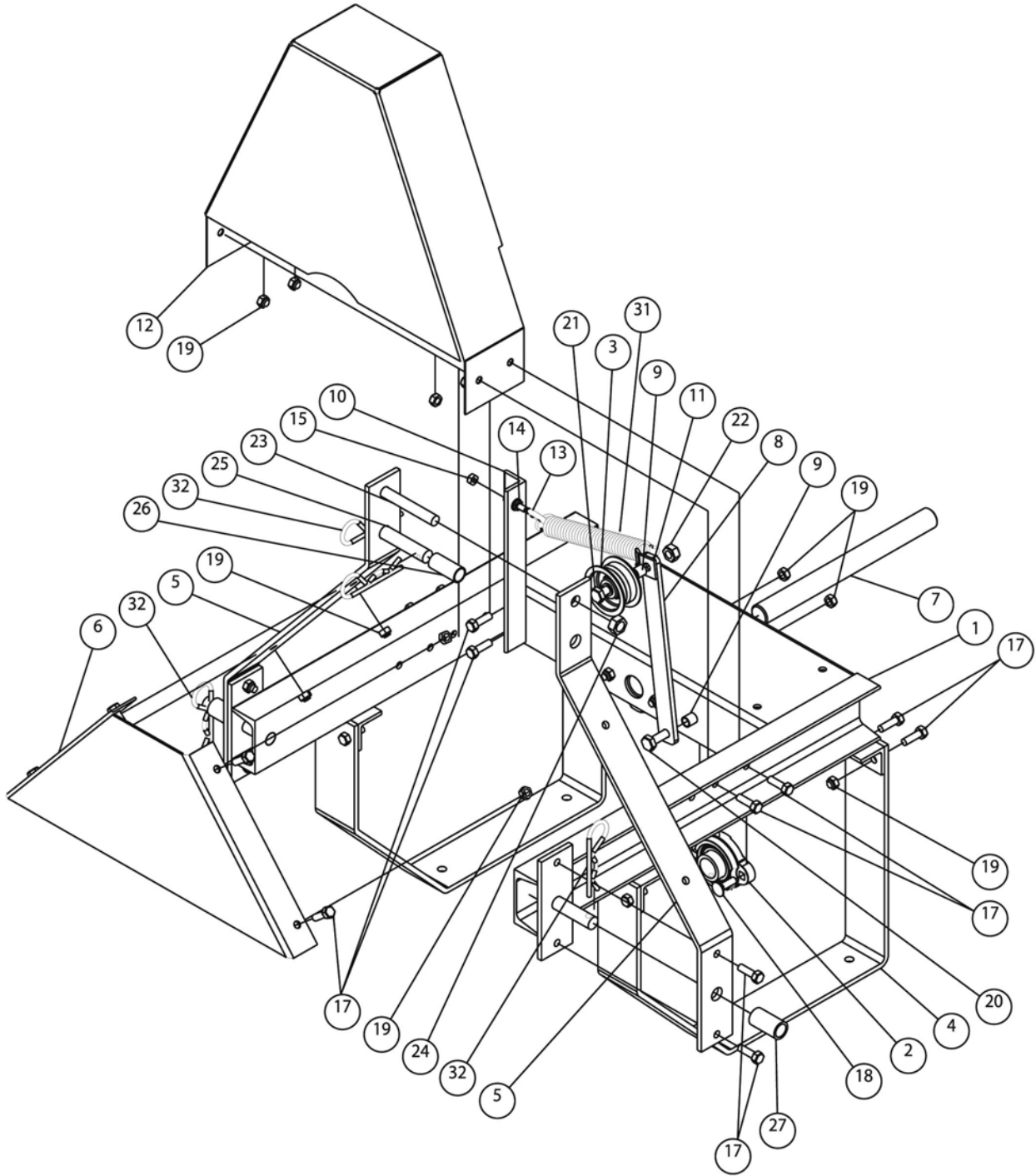

TPH-CHP FRAME ASSEMBLY

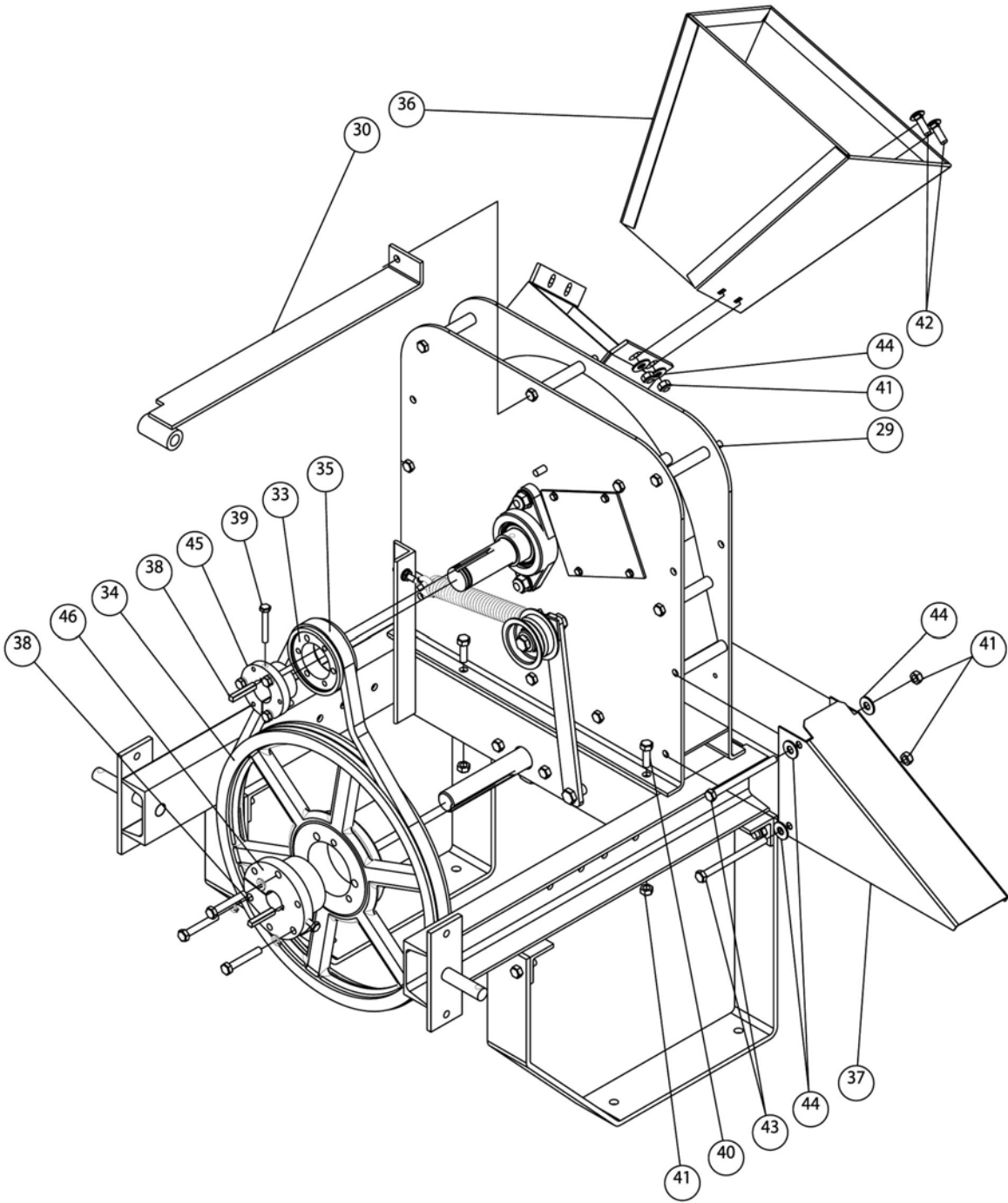

TPH-CHP BASIC & PULLEY ASSEMBLY

## TPH-CHP PARTS LIST

1	913-0289	1	FRAME WELDMENT
2	030-0055	2	1" BEARING
3	909-0012	1	IDLER PULLEY
4	913-0293	2	SUPPORT LEGS
5	913-0294	2	TPH MOUNT BRACKET
6	913-0296	1	THP BRACE
7	913-0310	1	11" DRIVE SHAFT
8	908-0072	1	TENSIONER ARM
9	900-0092	2	SPACER
10	913-0302	1	SPRING MOUNT BRACKET
11	712-0029	1	RETURN BRACKET
12	913-0303	1	BELT GUARD
13	090-0411	1	1/4-20 X 2 1/2" EYE BOLT
14	090-0453	1	1/4-20 WHIX NUT
15	090-0470	1	1/4-20 NYLOCK NUT
17	090-0088	22	5/16-18 X 1" HHCS
18	090-0551	4	5/16-18 X 1" CARRIAGE BOLT
19	090-0460	30	5/16-18 NYLOCK NUT
20	090-0112	1	3/8-16 X 1 1/2" HHCS
21	090-0115	1	3/8-16 X 2 1/2" HHCS
22	090-0461	2	3/8-16 NYLOCK NUT
23	090-0370	1	1/2-13 X 3" HHCS
24	090-0050	1	1/2-13 GRIPCO LOCKNUT
25	913-0304	1	UPPER TPH MOUNT PIN
26	913-0311	1	UPPER TPH SPACER - 1.625"
27	913-0312	2	LOWER TPH SPACER - 1.6"
29	913-0285	1	CHIPPER BASIC
30	913-0361	1	UPPER SUPPORT WELDMENT
31	030-0329	1	SPRING - TPH BELT TENSIONER
32	500-0039	4	3/16 HAIR COTTER PIN
33	030-0051	1	3V3.35 2 GROOVE SHEAVE
34	030-0328	1	3V14 2 GROOVE SHEAVE
35	030-0330	1	3VX530 2 GROOVE BELT
36	913-0375	1	CHIPPER HOPPER WELDMENT
37	913-0023	1	DISCHARGE DEFLECTOR
38	703-0424	2	1/4 X 1/4 X 2" KEY
39	090-0680	2	1/4-20 X 1 3/4" HHCS ALL THREAD
40	090-0088	18	5/16-18 X 1" HHCS
41	090-0460	24	5/16-18 NYLOCK NUT
42	090-0462	4	5/16-18 3/4" CARRIAGE BOLT
43	090-0077	2	5/16-18 X 4" HHCS
44	090-0233	8	5/16 FLATWASHER
45	030-0052	1	SH BUSHING - 1 3/16" BORE
46	030-0333	1	SK BUSHING - 1"

913-0285  
CHIPPER BASIC MACHINE

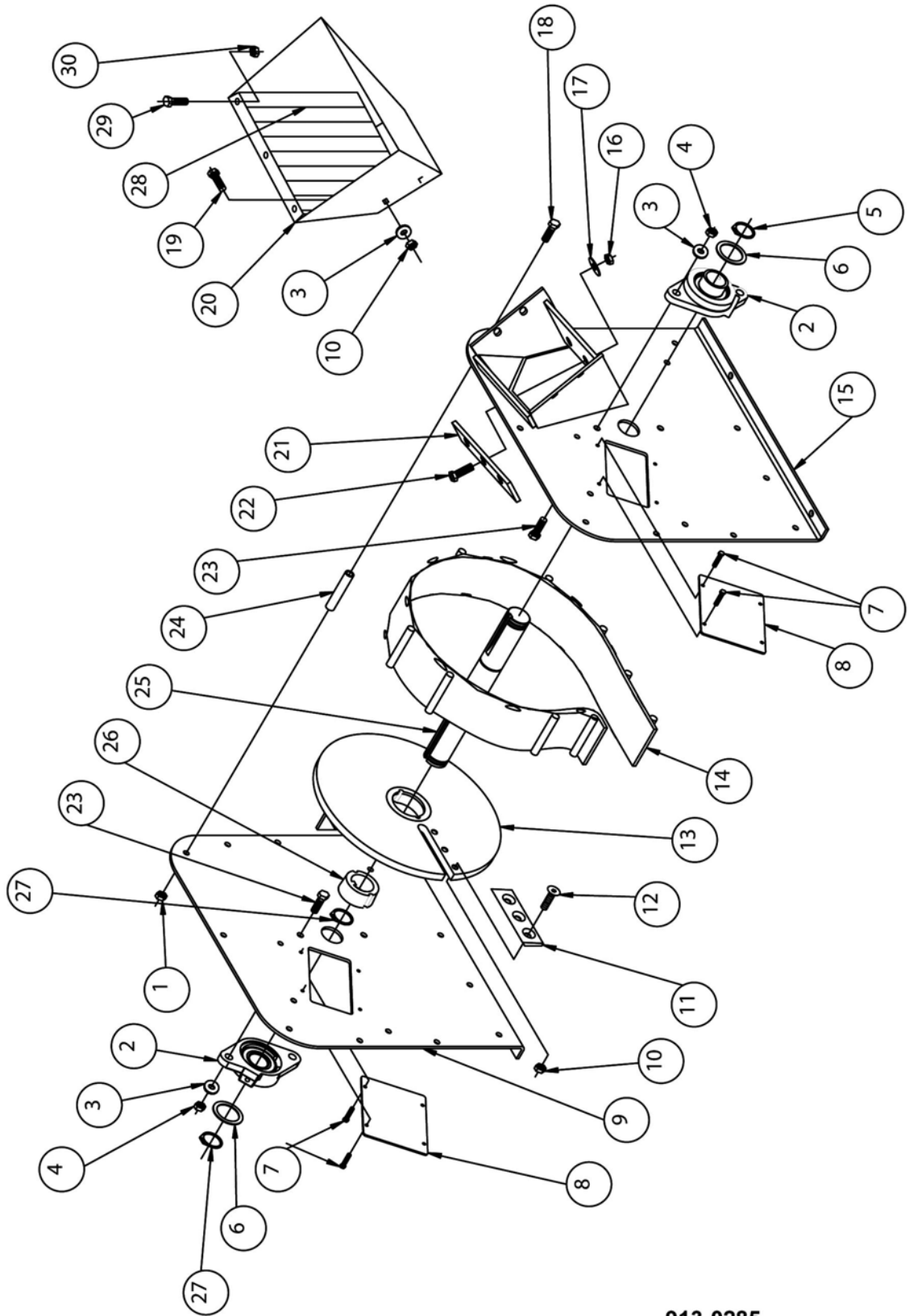

913-0285  
CHIPPER BASIC MACHINE

### 913-0285 CHIPPER BASIC MACHINE

ITEM #	PART #	QTY	DESCRIPTION
1	090-0048	9	5/16-18 GRIPCO LOCKNUT
2	030-0115	2	BEARING
3	090-0233	8	5/16 USS FLATWASHER
4	090-0049	4	3/8-16 GRIPCO LOCKNUT
5	030-0117	1	RETAINING RING
6	090-0024-3	2	SHIM
7	090-0162	8	10-32 X 3/8" SCREW
8	913-0210	2	ACCESS COVER
9	913-0034	1	DRIVE SIDE PLATE WELDMENT
10	090-0460	7	5/16-18 NYLOCK NUT
11	913-0270	1	KNIFE
12	090-0642	3	5/16-18 X 1 1/2" FSHCS
13	913-0286	1	CHIPPER DISK
14	913-0042	1	SCROLL WELDMENT
15	913-0279	1	CHIPPER SIDE PLATE WELDMENT
16	090-0470	3	1/4-20 NYLOCK LOCKNUT
17	090-0245	3	1/4 SAE FLATWASHER
18	090-0077	9	5/16-18 X 4" HHCS
19	090-0462	4	5/16-18 X 3/4" CARRIAGE BOLT
20	913-0375	1	CHIPPER HOPPER
21	913-0326	1	WEAR PLATE
22	090-0677	3	1/4-20 X 1" CARRIAGE BOLTS
23	090-0121	4	3/8-16 X 1 1/4" HHCS
24	913-0021	2	SCROLL TUBES
25	913-0334	1	FLYWHEEL SHAFT
26	030-0118	1	TAPERLOCK BUSHING
27	090-0676	2	HEAVY DUTY RETAINING RING
28	913-0376	1	BLOW BACK SHIELD
29	090-0504	3	10-24 X 1/2" HHCS
30	090-0643	3	10-24 U-CLIP
NOT SHOWN	150-0022	1	P.T.O. SHAFT ASSEMBLY
NOT SHOWN	080-0056	2	3/8-16 X 3/8" SET SCREW

## **NOTES**

**COUNTRY HOME PRODUCTS**  
Meigs Road, P.O. Box 25, Vergennes, Vermont 05491

**1(800)DR-OWNER(376-9637)**

02/10/04