

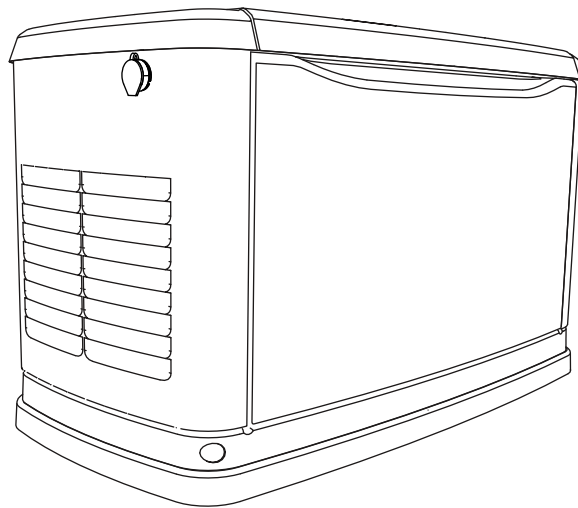

Owner's Manual

60 Hz Air-Cooled Generators

11 kW and 20 kW



WARNING

Loss of life. This product is not intended to be used in a critical life support application. Failure to adhere to this warning could result in death or serious injury.

(000209b)

Register your DR Power Equipment
product at

www.drpower.com

1-855-447-3734

Para español , visita: www.drpower.com/pages/content/customer-support/product-support

Pour le français, visiter : www.drpower.com/pages/content/customer-support/product-support

SAVE THIS MANUAL FOR FUTURE REFERENCE

Use this page to record important information about your generator set.

| | |
|------------------|--|
| Model: | |
| Serial: | |
| Production Date: | |
| Volts: | |
| LPV Amps: | |
| NG Amps: | |
| Hz: | |
| Phase: | |
| Controller P/N: | |
| STA MAC ID: | |
| SSID: | |

Record the information found on your unit data label on this page. See **General Information** for the location of the unit data label. The unit has a label plate affixed to the inside partition, to the left of the control panel console as shown in **Figure 2-1**. See **Operation** for directions on how to open the top lid and remove the front panel.

When contacting an Independent Authorized Service Dealer (IASD) about parts and service, always supply the complete model and serial numbers of the unit.

Operation and Maintenance: Proper maintenance and care of the generator ensures a minimum number of problems and keeps operating expenses at a minimum. It is the operator's responsibility to perform all safety checks, to verify all maintenance for safe operation is performed promptly, and to have the equipment checked periodically by an IASD. Normal maintenance, service, and replacement of parts are the responsibility of the owner/operator and are not considered defects in materials or workmanship within the terms of the warranty. Individual operating habits and usage may contribute to the need for additional maintenance or service.

When the generator requires servicing or repairs, the manufacturer recommends contacting an Independent Authorized Service Dealer for assistance. Authorized service technicians are factory-trained and are capable of handling all service needs. To locate the nearest Independent Authorized Service Dealer, please visit the dealer locator at:

<https://www.drpower.com/pages/content/customer-support/product-support/home-standby-generators>

| |
|--|
| <p style="text-align: center;"> WARNING CANCER AND REPRODUCTIVE HARM www.P65Warnings.ca.gov (000393a)</p> |
|--|

Table of Contents

Section 1: Safety Information

| | |
|-----------------------------------|----------|
| Introduction | 1 |
| Read This Manual Thoroughly | 1 |
| Safety Rules | 1 |
| How to Obtain Service | 2 |
| General Hazards | 2 |
| Exhaust Hazards | 3 |
| Electrical Hazards | 3 |
| Fire Hazards | 4 |
| Explosion Hazards | 4 |
| Battery Hazards | 5 |

Section 2: General Information

| | |
|---------------------------------------|-----------|
| The Generator | 7 |
| Data Decals | 8 |
| Specifications | 9 |
| Generator | 9 |
| Engine | 9 |
| Protection Systems | 10 |
| Emission Information | 10 |
| Fuel Requirements | 10 |
| Battery Requirements | 10 |
| Engine Oil Requirements | 10 |
| Activating the Generator | 10 |
| Wi-Fi Module | 10 |
| Replacement Parts | 11 |
| Accessories | 11 |

Section 3: Operation

| | |
|--|-----------|
| Site Prep Verification | 13 |
| Generator Enclosure | 13 |
| Opening the Lid | 13 |
| Removing the Front Access Panel | 13 |
| Intake Side Panel Removal | 14 |
| Main Line Circuit Breaker (Generator Disconnect) | 14 |
| LED Indicator Lights | 14 |
| Auxiliary Shutdown Switch | 15 |
| Control Panel Interface | 15 |
| Using the AUTO/OFF/MANUAL Interface | 15 |
| Interface Menu Displays | 16 |
| LCD Panel | 16 |
| Menu System Navigation | 18 |
| Setting the Exercise Timer | 20 |
| Battery Charger | 20 |
| Manual Transfer Operation | 21 |
| Transfer to Generator Power Source | 21 |
| Transfer to Utility Power Source | 22 |
| Automatic Transfer Operation | 22 |
| Automatic Sequence of Operation | 22 |
| Utility Failure | 22 |
| Cranking | 22 |
| Cold Smart Start | 23 |
| Load Transfer | 23 |
| Shutting Generator Down While Under Load or During a Utility Outage | 23 |

Section 4: Maintenance

Maintenance25
Preparing for Maintenance25
Performing Scheduled Maintenance25
Service Schedule26
 Maintenance Log 26
Checking Engine Oil Level27
 Engine Oil Requirements 27
Changing the Oil and Oil Filter28
Servicing the Air Cleaner28
Spark Plug(s)29
Valve Clearance Adjustment29
 Check Valve Clearance 29
 Adjust Valve Clearance 30
Battery Maintenance30
Cleaning the Sediment Trap31
Post Maintenance Checks32
Perform Leak Test33
Attention After Submersion33
Corrosion Protection33
**Remove From, and Return To Service
Procedure34**
 Remove From Service 34
 Return to Service 34

**Section 5: Troubleshooting / Quick
Reference Guide**

Generator Troubleshooting35
Quick Reference Guide37

Section 1: Safety Information

Introduction

Thank you for purchasing this compact, high performance, air-cooled, engine-driven generator. It is designed to automatically supply electrical power to operate critical loads during a utility power failure.

This unit is factory installed in an all-weather, metal enclosure intended exclusively for outdoor installation. This generator will operate using either vapor withdrawn liquid propane (LP) or natural gas (NG).

NOTE: This generator is suitable for supplying typical residential loads such as induction motors (sump pumps, refrigerators, air conditioners, furnaces, etc.), electronic components (computer, monitor, TV, etc.), lighting loads, and microwaves, when sized properly. This unit is equipped with a Wi-Fi® module, which enables the generator owner to monitor generator status from anywhere he or she has Internet access.

NOTE: Wi-Fi® is a registered trademark of Wi-Fi Alliance®.

The information in this manual is accurate based on products produced at the time of publication. The manufacturer reserves the right to make technical updates, corrections, and product revisions at any time without notice.

Read This Manual Thoroughly



Consult Manual. Read and understand manual completely before using product. Failure to completely understand manual and product could result in death or serious injury. (000100a)

Study this manual carefully before installing, operating, or servicing this equipment. Become familiar with this owner's manual and with the unit. The generator can operate safely, efficiently, and reliably only if it is properly installed, operated, and maintained. Many accidents are caused by failing to follow simple and fundamental rules or precautions.

If any section of this manual is not understood, contact the nearest Independent Authorized Service Dealer (IASD) for starting, operating, and servicing procedures.

This manual must be used in conjunction with the appropriate installation manual and Wi-Fi manual.

SAVE THESE INSTRUCTIONS: The manufacturer suggests this manual and the rules for safe operation be copied and posted near the unit installation site. Safety should be stressed to all operators and potential operators of this equipment.

Safety Rules

The manufacturer cannot anticipate every possible circumstance that might involve a hazard. The alerts in this manual, and on tags and decals affixed to the unit, are not all inclusive. If using a procedure, work method, or operating technique that the manufacturer does not specifically recommend, verify that it is safe for others and does not render the equipment unsafe.

Throughout this publication, and on tags and decals affixed to the unit, DANGER, WARNING, CAUTION, and NOTE blocks are used to alert personnel to special instructions about a particular operation that may be hazardous if performed incorrectly or carelessly. Observe them carefully. Alert definitions are as follows:



Indicates a hazardous situation which, if not avoided, will result in death or serious injury.

(000001)



Indicates a hazardous situation which, if not avoided, could result in death or serious injury.

(000002)



Indicates a hazardous situation which, if not avoided, could result in minor or moderate injury.

(000003)

NOTE: Notes contain additional information important to a procedure and will be found within the regular text of this manual.

These safety alerts cannot eliminate the hazards that they indicate. Common sense and strict compliance with the special instructions while performing the action or service are essential to preventing accidents.

The operator is responsible for proper and safe use of the equipment. The manufacturer strongly recommends that if the operator is also the owner, to read the owner's manual and thoroughly understand all instructions before using this equipment. The manufacturer also strongly recommends instructing other users to properly start and operate the unit. This prepares them if they need to operate the equipment in an emergency.

How to Obtain Service

Contact an IASD for assistance when the generator requires servicing or repairs. Service technicians are factory-trained and are capable of handling all service needs. Please visit the dealer locator at: <https://www.drpower.com/pages/content/customer-support/product-support/home-standby-generators> to locate the nearest IASD.

When contacting a dealer about parts and service, always supply the complete model and serial numbers of the unit as given on its data plate (decal), which is located on the generator. See **Figure 2-1** for decal location. Record the model and serial numbers in the spaces provided on the inside front cover of this manual.

General Hazards

⚠ DANGER

Loss of life. Property damage. Installation must always comply with applicable codes, standards, laws and regulations. Failure to do so will result in death or serious injury. (000190)

⚠ DANGER

Automatic start-up. Disconnect utility power and render unit inoperable before working on unit. Failure to do so will result in death or serious injury. (000191)



⚠ WARNING

Loss of life. This product is not intended to be used in a critical life support application. Failure to adhere to this warning could result in death or serious injury. (000209b)

⚠ WARNING

Equipment damage. This unit is not intended for use as a prime power source. It is intended for use as an intermediate power supply in the event of temporary power outage only. Doing so could result in death, serious injury, and equipment damage. (000247a)

⚠ WARNING

Accidental Start-up. Disconnect the negative battery cable, then the positive battery cable when working on unit. Failure to do so could result in death or serious injury. (000130)

⚠ WARNING

Equipment damage. Only qualified service personnel may install, operate, and maintain this equipment. Failure to follow proper installation requirements could result in death, serious injury, and equipment or property damage. (000182a)



⚠ WARNING

Electrocution. Potentially lethal voltages are generated by this equipment. Render the equipment safe before attempting repairs or maintenance. Failure to do so could result in death or serious injury. (000187)

⚠ WARNING

Electric shock. Only a trained and licensed electrician should perform wiring and connections to unit. Failure to follow proper installation requirements could result in death, serious injury, and equipment or property damage. (000155a)



⚠ WARNING

Moving Parts. Do not wear jewelry when starting or operating this product. Wearing jewelry while starting or operating this product could result in death or serious injury. (000115)



⚠ WARNING

Moving Parts. Keep clothing, hair, and appendages away from moving parts. Failure to do so could result in death or serious injury. (000111)



⚠ WARNING

Hot Surfaces. When operating machine, do not touch hot surfaces. Keep machine away from combustibles during use. Hot surfaces could result in severe burns or fire. (000108)

⚠ WARNING

Equipment and property damage. Do not alter construction of, installation, or block ventilation for generator. Failure to do so could result in unsafe operation or damage to the generator. (000146)

⚠ WARNING

Risk of injury. Do not operate or service this machine if not fully alert. Fatigue can impair the ability to service this equipment and could result in death or serious injury. (000215)

⚠ WARNING

Environmental Hazard. Always recycle batteries at an official recycling center in accordance with all local laws and regulations. Failure to do so could result in environmental damage, death or serious injury. (000228)

⚠ WARNING

Injury and equipment damage. Do not use generator as a step. Doing so could result in falling, damaged parts, unsafe equipment operation, and could result in death or serious injury. (000216)

- Inspect the generator regularly, and contact the nearest IASD for parts needing repair or replacement.

Exhaust Hazards



⚠ DANGER

Asphyxiation. Running engines produce carbon monoxide, a colorless, odorless, poisonous gas. Carbon monoxide, if not avoided, will result in death or serious injury. (000103)



⚠ WARNING

Asphyxiation. Always use a battery operated carbon monoxide alarm indoors and installed according to the manufacturer's instructions. Failure to do so could result in death or serious injury. (000178a)

⚠ WARNING

Equipment and property damage. Do not alter construction of, installation, or block ventilation for generator. Failure to do so could result in unsafe operation or damage to the generator. (000146)

- The generator must be installed and operated outdoors only.

Electrical Hazards



⚠ DANGER

Electrocution. Contact with bare wires, terminals, and connections while generator is running will result in death or serious injury. (000144)



⚠ DANGER

Electrocution. Never connect this unit to the electrical system of any building unless a licensed electrician has installed an approved transfer switch. Failure to do so will result in death or serious injury. (000150)

⚠ DANGER

Electrical backfeed. Use only approved switchgear to isolate generator from the normal power source. Failure to do so will result in death, serious injury, and equipment damage. (000237)



⚠ DANGER

Electrocution. Verify electrical system is properly grounded before applying power. Failure to do so will result in death or serious injury. (000152)



⚠ DANGER

Electrocution. Do not wear jewelry while working on this equipment. Doing so will result in death or serious injury. (000188)



⚠ DANGER

Electrocution. Water contact with a power source, if not avoided, will result in death or serious injury. (000104)



⚠ DANGER

Electrocution. In the event of electrical accident, immediately shut power OFF. Use non-conductive implements to free victim from live conductor. Apply first aid and get medical help. Failure to do so will result in death or serious injury. (000145)

Fire Hazards



⚠️WARNING

Fire hazard. Do not obstruct cooling and ventilating airflow around the generator. Inadequate ventilation could result in fire hazard, possible equipment damage, death or serious injury. (000217)



⚠️WARNING

Fire and explosion. Installation must comply with all local, state, and national electrical building codes. Noncompliance could result in unsafe operation, equipment damage, death or serious injury. (000218)



⚠️WARNING

Fire hazard. Use only fully-charged fire extinguishers rated “ABC” by the NFPA. Discharged or improperly rated fire extinguishers will not extinguish electrical fires in automatic standby generators. (000219)



⚠️WARNING

Consult Manual. Read and understand manual completely before using product. Failure to completely understand manual and product could result in death or serious injury. (000100a)



⚠️WARNING

Electrocution. Refer to local codes and standards for safety equipment required when working with a live electrical system. Failure to use required safety equipment could result in death or serious injury. (000257)



⚠️WARNING

Risk of Fire. Unit must be positioned in a manner that prevents combustible material accumulation underneath. Failure to do so could result in death or serious injury. (000147)

- Comply with regulations the Occupational Safety and Health Administration (OSHA) has established. Also verify the generator is installed in accordance with the manufacturer’s instructions and recommendations. Following proper installation, do nothing that might alter a safe installation and render the unit in noncompliance with the aforementioned codes, standards, laws, and regulations.

Explosion Hazards



⚠️DANGER

Explosion and fire. Fuel and vapors are extremely flammable and explosive. No leakage of fuel is permitted. Keep fire and spark away. Failure to do so will result in death or serious injury. (000192)

⚠️DANGER

Explosion and fire. Connection of fuel source must be completed by a qualified professional technician or contractor. Incorrect installation of this unit will result in death, serious injury, and property and equipment damage. (000151a)



⚠️DANGER

Risk of fire. Allow fuel spills to completely dry before starting engine. Failure to do so will result in death or serious injury. (000174)



⚠️WARNING

Risk of Fire. Hot surfaces could ignite combustibles, resulting in fire. Fire could result in death or serious injury. (000110)

Battery Hazards



⚠ DANGER

Electrocution. Do not wear jewelry while working on this equipment. Doing so will result in death or serious injury.

(000188)



⚠ WARNING

Explosion. Do not dispose of batteries in a fire. Batteries are explosive. Electrolyte solution can cause burns and blindness. If electrolyte contacts skin or eyes, flush with water and seek immediate medical attention.

(000162)



⚠ WARNING

Explosion. Batteries emit explosive gases while charging. Keep fire and spark away. Wear protective gear when working with batteries. Failure to do so could result in death or serious injury.

(000137a)



⚠ WARNING

Electrical shock. Disconnect battery ground terminal before working on battery or battery wires. Failure to do so could result in death or serious injury.

(000164)



⚠ WARNING

Risk of burns. Batteries contain sulfuric acid and can cause severe chemical burns. Wear protective gear when working with batteries. Failure to do so could result in death or serious injury.

(000138a)



⚠ WARNING

Risk of burn. Do not open or mutilate batteries. Batteries contain electrolyte solution which can cause burns and blindness. If electrolyte contacts skin or eyes, flush with water and seek immediate medical attention.

(000163a)

⚠ WARNING

Environmental Hazard. Always recycle batteries at an official recycling center in accordance with all local laws and regulations. Failure to do so could result in environmental damage, death or serious injury.

(000228)

Always recycle batteries in accordance with local laws and regulations. Contact your local solid waste collection site or recycling facility to obtain information on local recycling processes. For more information on battery recycling, visit the Battery Council International website at: <http://batteryCouncil.org>

This page intentionally left blank.

Section 2: General Information

The Generator

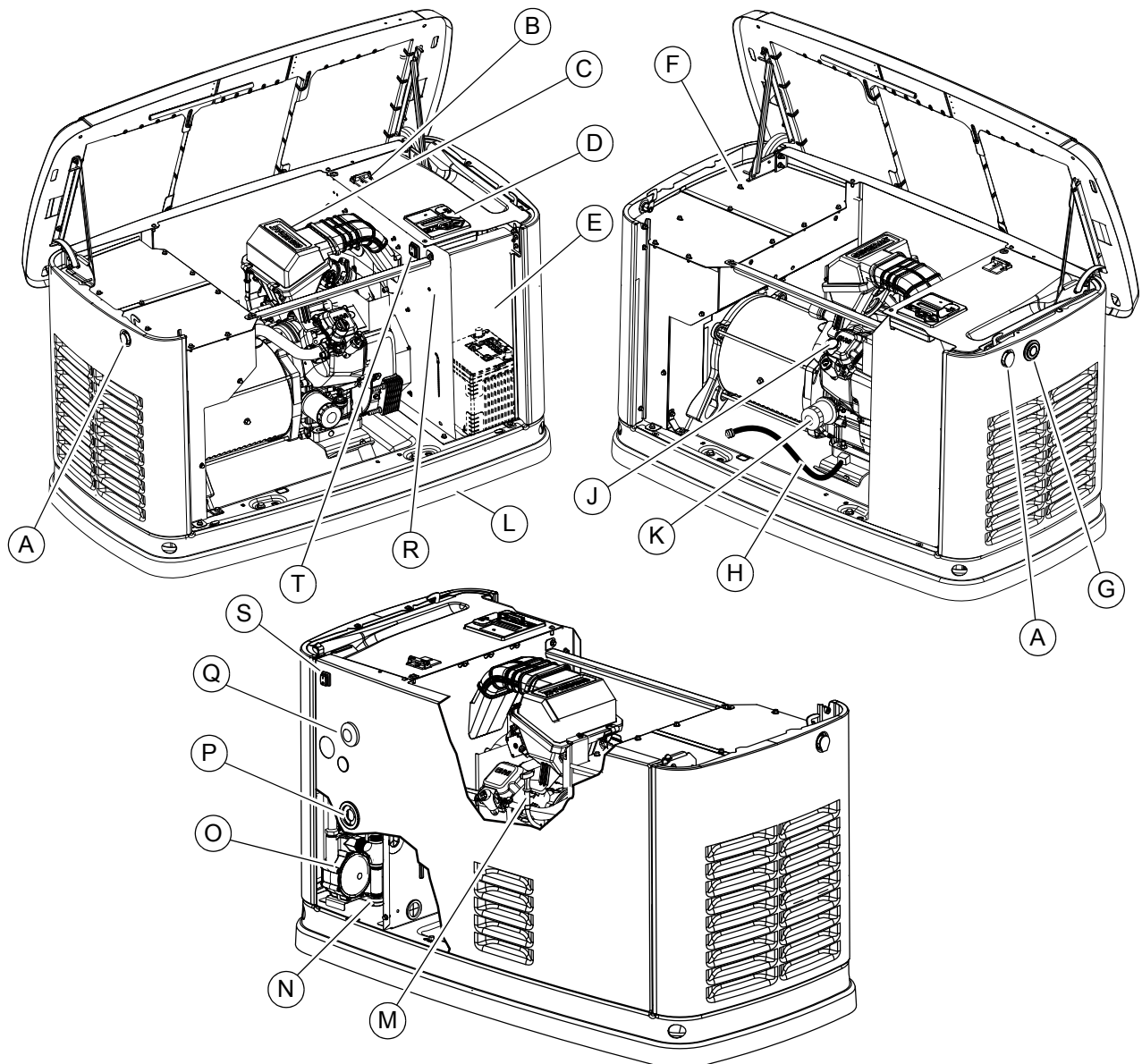

001786

Figure 2-1. 11 kW and 20 kW—Components and Control Locations

| | | | |
|--|---------------------------------|--------------------------|--|
| A. Lock with Cover | F. Exhaust Enclosure | L. Composite Base | Q. Wi-Fi Module |
| B. Main Line Circuit Breaker (Generator Disconnect) | G. Status LED Indicators | M. Oil Dipstick | R. Data Decal Location |
| C. Airbox with Air Cleaner | H. Oil Drain | N. Sediment Trap | S. Auxiliary Shutdown Switch (all models) |
| D. Control Panel | J. Oil Fill Cap | O. Fuel Regulator | T. Auxiliary Shutdown Switch (20 kW) |
| E. Battery Compartment (Battery not supplied) | K. Oil Filter | P. Fuel Inlet | |

Data Decals

Two decals on the generator provide information about the unit itself and required fuel inlet pressure for proper operation.

| | |
|---|--|
| <div data-bbox="311 333 605 1115" data-label="Form"> <p>DR POWER EQUIPMENT</p> <p>MODEL: G0065510 SERIAL: 1000000XXX ITEM NO: 0065510 PROD DATE: 20xx/xx/xx VOLTS: 120/240 1 PHASE LPV AMPS: 183.3/91.7 HZ: 60 NG AMPS: 162.5/81.3 RPM: 3600 INSULATION CLASS: F 10 PF CONTROLLER P/N: 0J8371C COUNTRY OF ORIGIN: USA DUTY RTG: _____ X'D 0.23 X'D 0.20 RATED AMBIENT TEMP: 40°C FOR STANDBY SERVICE</p> <p>NEUTRAL FLOATING UNBALANCED LOAD MANUF. LOC. CAPACITY: 25% 1004</p> <p>RAINPROOF ENCLOSURE</p> <p> SwRI ID No. 13204-01-01 Compliant with Clause 12 of Section 4.14 of NFPA 37 LISTED BY: Southwest Research Institute San Antonio, Texas</p> <p>NOTE 1 ISO CHAR. MAX _____ NOTE 2 ISO CHAR. MAX _____ NOTE 3 ISO CHAR. MAX _____ NOTE 4 ISO CHAR. MAX _____ NOTE 5 ISO CHAR. MAX _____ NOTE 6 ISO CHAR. MAX _____ NOTE 7 ISO CHAR. MAX _____</p> <p>GENERAC POWER SYSTEMS, INC WALKESHA, WI USA 53189 0L2157</p> </div> | <p>Model Data Decal</p> <p>Includes important information about the unit including:</p> <ul style="list-style-type: none"> • model number • serial number • production date • voltage • frequency • amps • country of origin • rated ambient temperature. <p>The model data decal also includes applicable certification symbols from independent testing agencies.</p> |
| <div data-bbox="285 1188 644 1430" data-label="Form"> <p>FUEL INLET</p> <p>PRIMARY FUEL _____ SERIAL # _____</p> <p>DIESEL MAX FLOW RATE: _____ BTU/HR</p> <p>NATURAL GAS MIN. INLET PRESSURE: _____ in W.C. MAX INLET PRESSURE: _____ in W.C. MAX FLOW RATE: _____ BTU/HR</p> <p>LP-VAPOR MIN. INLET PRESSURE: _____ in W.C. MAX INLET PRESSURE: _____ in W.C. MAX FLOW RATE: _____ BTU/HR</p> <p>_____ FLEX HOSE CONNECTION ONLY</p> </div> | <p>Fuel Inlet Pressure</p> <p>Displays unit serial number, along with minimum and maximum inlet pressures for natural gas (NG) and liquid propane (LP) supply. Space is provided for the installer to enter maximum flow rates based on installed pipe sizes and lengths.</p> |

Specifications

Generator

| Model | 11 kW | 20 kW |
|---|---|---------|
| Rated Voltage | 240 | |
| Rated Maximum Load Current (Amps) at Rated Voltage with LP* | 45.8 | 83.3 |
| Main Line Circuit Breaker (Generator Disconnect) | 50 Amp | 90 Amp |
| Phase | 1 | |
| Rated AC Frequency | 60 Hz | |
| Battery Requirement (Field supplied) | 12 volts, Group 26R-540CCA Minimum or Group 35AGM-650CCA Minimum (see Replacement Parts) | |
| Enclosure | Aluminum | |
| Weight (lb/kg) (without battery) | 348/158 | 448/203 |
| Normal Operating Range | This unit is tested in accordance to UL 2200 standards with an operating temperature of -20 °F (-29 °C) to 122 °F (50 °C). For areas where temperatures fall below 32 °F (0 °C) a cold weather kit is recommended. When operated above 77 °F (25 °C), there may be a decrease in engine power. See Engine . | |
| These generators are rated in accordance with UL 2200, Safety Standard for Stationary Engine Generator Assemblies, and CSA-C22.2 No. 100-04 Standard for Motors and Generators. | | |
| * Natural gas ratings will depend on specific fuel joules/BTU content. Typical derates are between 10-20% off the LP gas rating. | | |

Engine

| Model | 11 kW | 20 kW |
|--|---------------------------------------|---------------------------------|
| Type of Engine | G-Force 500 Series | G-Force 1000 Series |
| Number of Cylinders | 2 | 2 |
| Displacement | 530 cc | 999 cc |
| Cylinder Block | Aluminum with cast iron sleeve | |
| Recommended Spark Plug | See Replacement Parts | |
| Spark Plug Gap | 0.030 in (0.76 mm) | 0.040 in (1.02 mm) |
| Valve Clearance | 0.002–0.004 in (0.05–0.1 mm) | 0.002–0.004 in (0.05–0.1 mm) |
| Starter | 12 VDC | |
| Oil Capacity Including Filter | Approx. 1.7 qt (1.6 L) | Approx. 1.9 qt (1.8 L) |
| Recommended Oil Filter | See Replacement Parts | |
| Recommended Air Filter | See Replacement Parts | |
| Engine power is subject to and limited by such factors as fuel BTU/joules, ambient temperature, and altitude. Engine power decreases approximately 3.5% for each 1000 ft (304.8 m) above sea level, and also will decrease about 1% for each 10 °F (6 °C) above 60 °F (15 °C) ambient temperature. | | |

A detailed specification sheet for your particular generator is available from your local Independent Authorized Service Dealer (IASD).

Protection Systems

The generator may need to run for long periods of time with no operator present to monitor engine or generator conditions. The generator is equipped with protection systems to automatically shut down the unit to protect against potentially damaging conditions. Some of these systems include:

Alarms:

- High Temperature
- Low Oil Pressure
- Overcrank
- Overspeed
- Overvoltage
- Undervoltage
- Overload
- Underspeed
- RPM Sensor Loss
- Controller Fault
- Wiring Error
- Stepper Overcurrent

Warnings:

- Charger Warning
- Charger Missing AC
- Low Battery
- Battery Problem
- Exercise Set Error
- USB Warning
- Download Failure

The control panel contains a display alerting the operator when a fault condition occurs. The above list is not all-inclusive. See [Operation](#) for more information about alarms and control panel operation.

NOTE: A warning indicates a condition on the generator which should be addressed, but will not shut down the generator. An alarm shuts down the generator to protect the system from any damage. In the event of an alarm, an owner can clear the alarm and restart the generator prior to contacting an IASD. Contact an IASD if the intermittent issue occurs again.

Emission Information

The United States Environmental Protection Agency (US EPA) (and California Air Resources Board (CARB), for engines/equipment certified to California standards) requires that this engine/equipment complies with exhaust and evaporative emissions standards. Locate the emissions compliance decal on the engine to determine applicable standards. For emissions warranty information, please reference the included emissions warranty. Follow the maintenance specifications in [Maintenance](#) to ensure the engine complies with applicable emissions standards for the duration of the product's life.

This generator is certified to operate on liquid propane vapor fuel or pipeline natural gas.

The Emission Control System code is EM (Engine Modification). The Emission Control System on this generator consists of the following:

| System | Components |
|---------------|---|
| Air Induction | - Intake Manifold - Air Cleaner |
| Fuel Metering | - Carburetor and Mixer Assembly - Fuel Regulator |
| Ignition | - Spark Plug - Ignition Module |
| Exhaust | - Exhaust Manifold - Muffler |

Fuel Requirements



⚠ DANGER

Explosion and Fire. Fuel and vapors are extremely flammable and explosive. Add fuel in a well ventilated area. Keep fire and spark away. Failure to do so will result in death or serious injury. (000105)

The engine has been fitted with a dual fuel carburetion system. The unit will run on natural gas or LP gas (vapor), but it has been factory set to run on natural gas. The fuel system will be configured for the available fuel source during installation.

Recommended fuels should have a BTU content of at least 1000 BTUs per ft³ (37.26 megajoules per m³) for natural gas, or at least 2500 BTUs per ft³ (93.15 megajoules per m³) for LP gas (vapor).

NOTE: If converting to LP gas from natural gas, a minimum LP tank size of 250 gal (946 L) is recommended. See the installation manual for complete procedures and details.

Battery Requirements

12 volts, Group 26R-540CCA minimum or Group 35AGM-650CCA minimum (not included with unit.) See [Maintenance](#) for proper battery maintenance procedures.

Engine Oil Requirements

See [Engine Oil Requirements](#) in the Maintenance section for proper oil viscosity.

Activating the Generator

The generator should be activated upon initial start-up. See the installation manual for complete instructions.

Wi-Fi Module

The generator is equipped with a Wi-Fi module. Refer to the Wi-Fi module owner's manual for further instruction.

Replacement Parts

| Description | 11 kW | 20 kW |
|-----------------------|---|-----------------------------------|
| 26R Exide Battery | 0H3421S | |
| Spark Plug | 0E9368 (RL87YC or equivalent) | 0G0767A (RC12YC or equivalent) |
| Oil Filter | 070185E | |
| Air Filter | 0E9371A | 0J8478 |
| Control Panel Fuse | 0D7178T | |
| Transfer Switch Fuses | Refer to Transfer Switch Manual for part number | |

Accessories

NOTE: Performance enhancing accessories are available for air-cooled generators. Contact an IASD or visit www.drpower.com for additional information on replacement parts and accessories.

| Accessory | Description |
|--|--|
| Cold Weather Accessories*— <ul style="list-style-type: none"> • Battery Pad Warmer • Oil Warmer • Breather Warmer <i>* each sold separately</i> | <ul style="list-style-type: none"> • Recommended in areas where temperatures fall below 0 °F (-18 °C). <i>(Not necessary for use with AGM-style batteries)</i> • Recommended in areas where temperatures fall below 0 °F (-18 °C). • Recommended in areas where heavy icing occurs. |
| Scheduled Maintenance Kit | Includes all pieces necessary to perform maintenance on the generator along with oil recommendations. |
| Fascia Base Wrap | The fascia base wrap snaps together around the bottom of the new air-cooled generators. This offers a sleek, contoured appearance as well as protection from rodents and insects by covering the lifting holes located in the base. Requires use of the mounting pad shipped with the generator. |
| Touch-Up Paint Kit | Very important to maintain the look and integrity of the generator enclosure. This kit includes touch-up paint and instructions. |
| Wi-Fi LP Fuel Level Monitor | The Wi-Fi enabled LP fuel level monitor provides constant monitoring of the connected LP fuel tank. Monitoring the LP tank level is an important step in making sure your generator is ready to run during an unexpected power failure. Status alerts are available through the Mobile Link™ application informing you when your LP tank needs a refill. |

This page intentionally left blank.

Section 3: Operation

Site Prep Verification

The generator must be installed to allow unimpeded airflow into and out of the generator.

Mechanical and gravity outdoor air intake openings for air distribution and supply systems must be located not less than 10 ft (3.05 m) horizontally from the generator enclosure. See Section 401.4 in the ICC Mechanical Code for additional information.

Verify all shrubs or tall grasses within 3 ft (0.91 m) of the intake and discharge louvers on the sides of the enclosure have been removed. Install the generator on high ground where water levels will not rise and endanger it. This unit should not operate in or be subjected to standing water. Verify all potential water sources such as water sprinklers, roof run-off, rain gutter downspouts, and sump pump discharges are directed away from the generator enclosure.

⚠ DANGER

Automatic start-up. Disconnect utility power and render unit inoperable before working on unit. Failure to do so will result in death or serious injury.

(000191)

Generator Enclosure

Enclosure lid is locked prior to shipment. A set of keys is attached to the cardboard on top of the generator. An additional set of keys is attached to the pallet bracket on the front intake end of the generator.

NOTE: Keys provided with this unit are intended for service personnel use only.

Opening the Lid

Two locks secure the lid—one on each side (A in [Figure 3-1](#)). Open the protective rubber cap to access the keyhole, and press down on the lid above the side lock and unlock the latch to properly open the lid.

Repeat for the other side. The lid may appear stuck if pressure is not applied from the top.

Always verify the side locks are unlocked before attempting to lift the lid.

Removing the Front Access Panel

Remove the front access panel by lifting it straight up and out once the lid is open.

Always lift the front access panel straight up before pulling it away from the enclosure (B and C in [Figure 3-1](#)). Do not pull the panel away from the enclosure before lifting up (D in [Figure 3-1](#)).

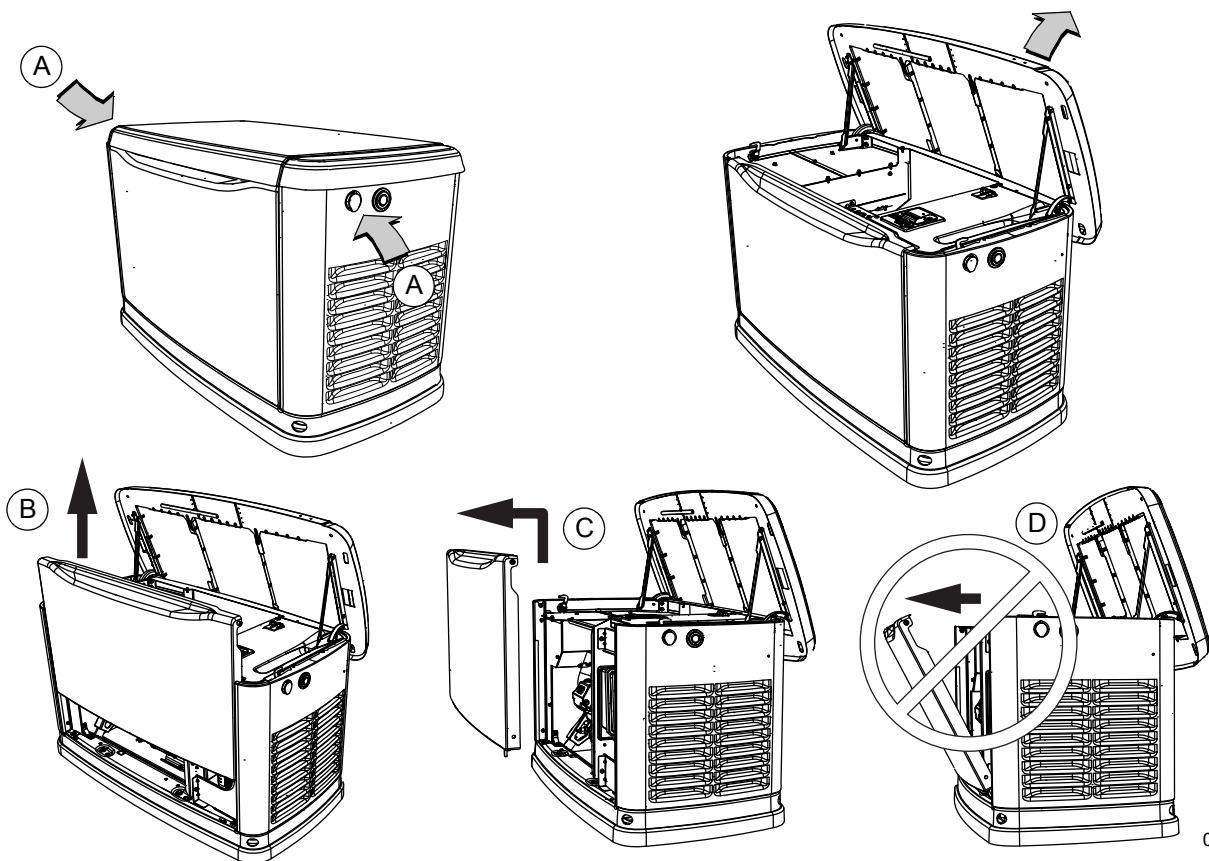

001797

Figure 3-1. Side Lock Location and Front Panel Removal

Intake Side Panel Removal

See **Figure 3-2**. The intake side panel (A) must be removed to access the battery compartment, fuel regulator, and sediment trap.

1. Raise lid and remove front panel.
2. Use a hex key to remove two mounting screws (B) and L-bracket screw (C).

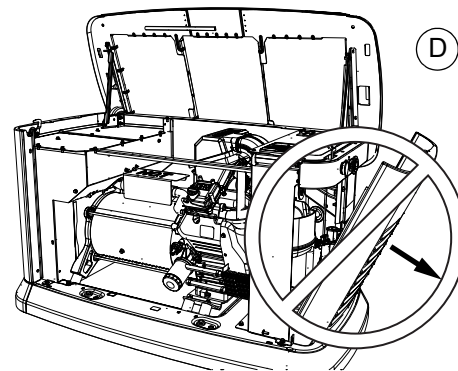
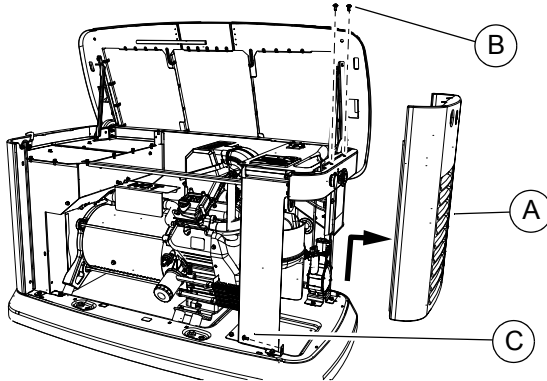

002961

Figure 3-2. Intake Side Panel Removal

Main Line Circuit Breaker (Generator Disconnect)

This is a 2-pole breaker rated according to relevant specifications. See “A” in **Figure 3-3**.

The breaker can be locked in the OFF (OPEN) position for security. Use an appropriately-sized padlock (not included) with a shackle long enough to pass through both lock tabs (B).

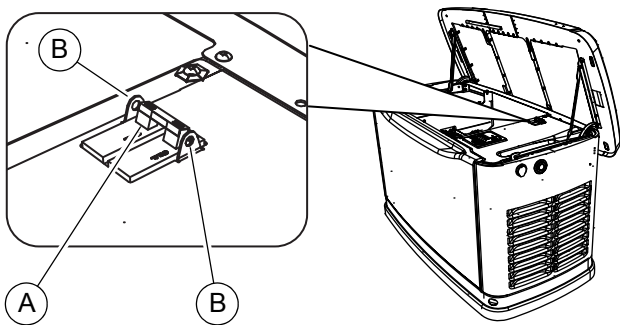

001810

Figure 3-3. Main Breaker

NOTE: DO NOT lock out the MLCB during normal generator operation. Doing so will compromise automatic standby functionality.

LED Indicator Lights

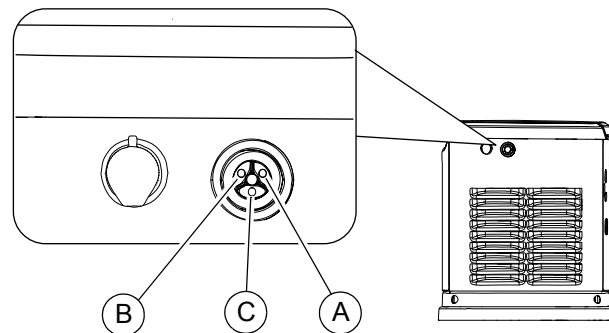

001791

Figure 3-4. LED Indicator Lights

See **Figure 3-4**. Three LEDs are visible behind a translucent lens on the generator side panel. These LEDs indicate generator operating status.

- Green LED “Ready” light (A) is illuminated when utility is present and the control panel is in AUTO mode. The LED flashes when the automatic transfer switch converts to generator power during a utility power outage.
- Red LED “Alarm” light (B) is illuminated when the generator is OFF or a fault is detected. Contact an IASD.
- Yellow LED “Non-Critical Alert” light (C) is illuminated when maintenance is required.

NOTE: Yellow LED may be illuminated at the same time as either the red or green LED.

Auxiliary Shutdown Switch

All generators are equipped with an external means of shutting down the generator which complies with the latest NEC code requirement. The primary generator shutdown sequence is described in [Shutting Generator Down While Under Load or During a Utility Outage](#).

See [Figure 3-5](#). There is an auxiliary shutdown switch on the exterior of the generator back panel. This switch shuts down the generator and disables restarts.

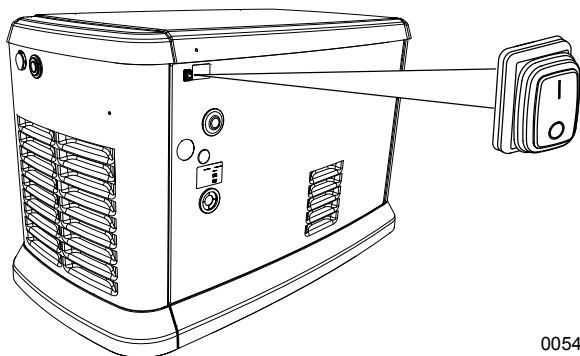

005491

Figure 3-5. External Auxiliary Shutdown Switch (all models)



Equipment Damage. The auxiliary shutdown switch is not to be used to power down the unit under normal operating circumstances. Doing so will result in equipment damage. (000399)

NOTE: Whenever possible, perform the primary shutdown procedure before disabling the generator with the auxiliary shutdown switch.

See [Figure 3-6](#). 20 kW generators also have an auxiliary shutdown switch located inside the generator.

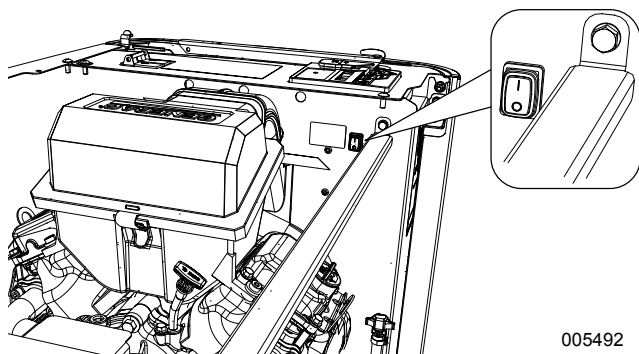

005492

Figure 3-6. Internal Auxiliary Shutdown Switch (20 kW)

The generator will not start if either switch is OPEN (O). The controller displays an “Auxiliary Shutdown” alarm, and the red LED “Alarm” light illuminates. To clear this condition, set the switch or switches to CLOSED (I). Clear the alarm by pressing the OFF mode button, and then ENTER. The generator can then be placed back in AUTO or MANUAL mode.

Control Panel Interface

See [Figure 3-7](#). The control panel interface (A) is located under the enclosure lid. Verify both the left and right side locks are unlocked before attempting to lift the lid of the enclosure. Open the lid as directed in [Opening the Lid](#).

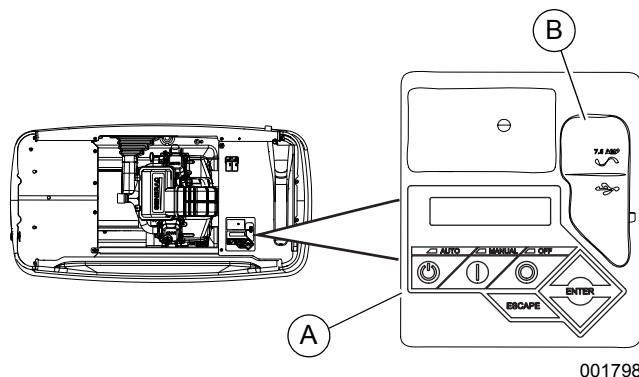

001798

Figure 3-7. Generator Control Panel

The 7.5A fuse is located beneath the rubber cover (B) to the right of the control panel.

Verify both left and right side locks are securely out of the way before closing the unit.

All appropriate panels must be in place during any operation of the generator. This includes operation by a servicing technician while conducting troubleshooting procedures.

Using the AUTO/OFF/MANUAL Interface

| Button | Description of Operation |
|--------|--|
| AUTO | Activates fully automatic system operation. It allows the unit to automatically start and exercise the generator according to the exercise timer (see Setting the Exercise Timer). The green LED flashes when the automatic transfer switch converts to generator power during a utility power outage. |
| OFF | Shuts down the engine and prevents automatic operation of the unit. |
| MANUAL | Cranks and starts the generator. Transfer to standby power will not occur unless there is a utility failure. The blue LED flashes when the automatic transfer switch converts to generator power during a utility power outage. |

NOTE: Damage caused by mis-wiring of interconnect wires is not warrantable.

Interface Menu Displays

LCD Panel

| Feature | Description |
|-------------------|---|
| HOME page | Default page displayed if no buttons are pressed for 60 seconds. Normally shows current status message, and current date and time. The highest priority active alarm/warning is automatically posted on this page, as well as flashing the backlight when such a condition is detected. In the case of multiple alarms/warnings, only the first message is displayed. Press the OFF mode button and then the ENTER button to clear an alarm or warning. When "Hours of Protection" is displayed, this represents the total time the generator has been monitoring utility supply and ready to provide backup power if needed. |
| Display Backlight | Normally off. The backlight will automatically illuminate and remain on for 30 seconds if the operator presses any button. |
| MAIN MENU page | Allows the operator to navigate to all other pages or sub-menus by using the arrow keys and the ENTER button. Page can be accessed at any time with several presses of the dedicated ESCAPE button. Each press of the ESCAPE button takes the operator to the previous menu until the MAIN MENU displays. This page contains information for History; Status; Edit; and Debug. |

This page intentionally left blank.

Menu System Navigation

Press the ESCAPE button from any page to access the MENU, You may need to press the ESCAPE button several times before reaching the MENU page. Navigate to the desired menu by using the ↑/↓ buttons. Press the ENTER button when the desired menu is displayed and flashing,

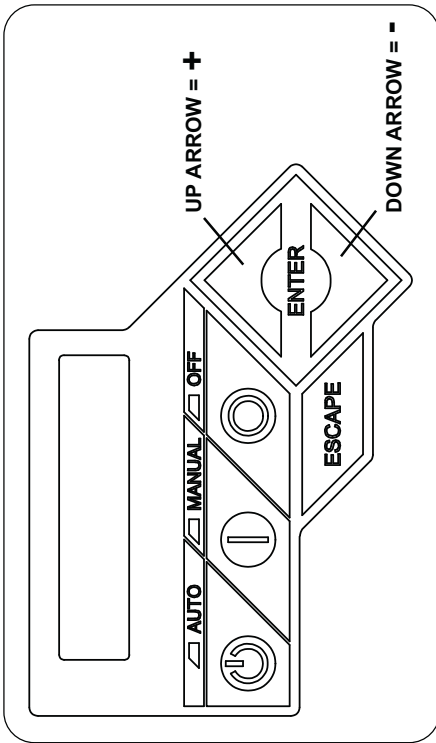

006667

EVOLUTION 2.0 / SYNC 3.0 HSB MENU MAP

Note: Menu functions and features may vary depending on unit model and firmware revision.

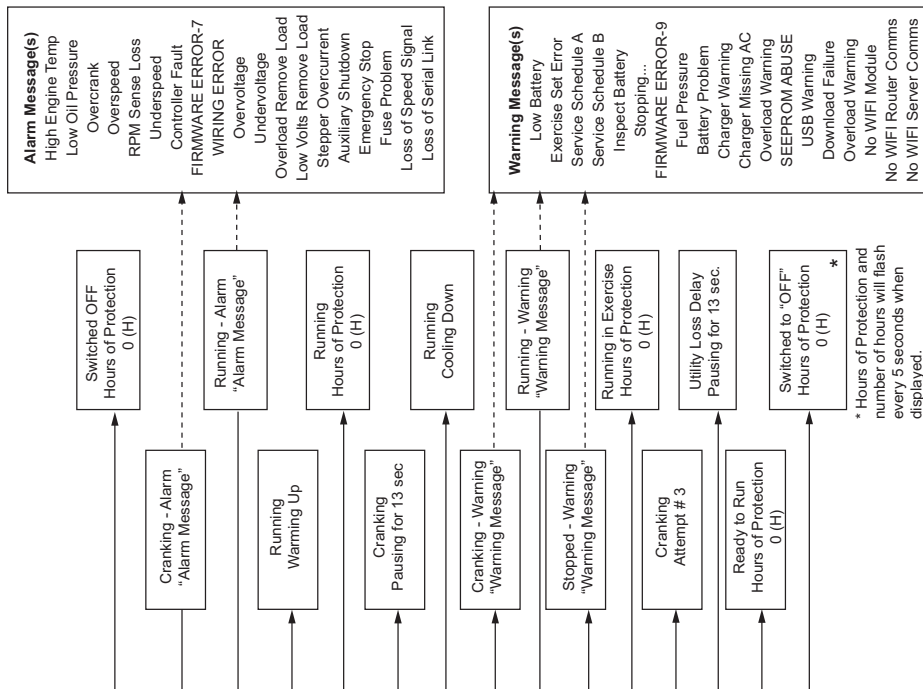
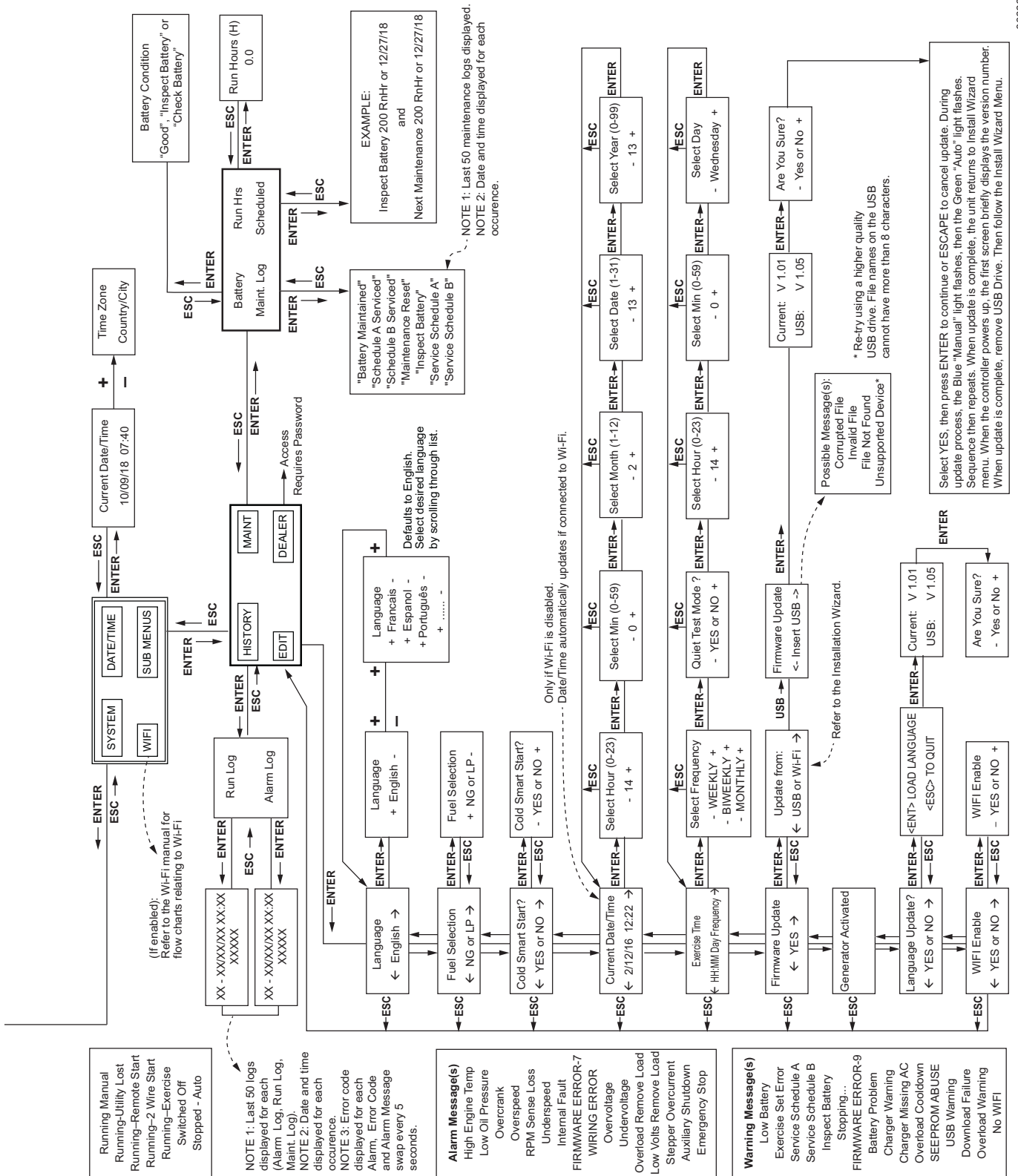

Figure 3-8. Navigation Menu



006667

Figure 3-9. Navigation Menu

Setting the Exercise Timer

This generator is equipped with a configurable exercise timer. Configuration can be performed directly at the control panel or through the Mobile Link™ application. There are two settings for the exercise timer:

Day/Time: The generator will start and exercise for the period defined, on the day of the week and at the time of day specified. During this exercise period, the unit runs for approximately five minutes and then shuts down.

NOTE: If Wi-Fi is enabled, the exercise timer will automatically adjust for Daylight Savings Time.

Exercise frequency: Exercise frequency can be set to Weekly, Biweekly, or Monthly. If Monthly is selected, the day of the month must be selected from 1-28. The generator will exercise on that day each month. Transfer of loads to the generator output does not occur during the exercise cycle unless utility power is lost.

NOTE: The exercise feature will operate only when the generator is in AUTO mode, and will not work unless this procedure is performed. If Wi-Fi is NOT enabled, the current date/time will need to be reset every time the 12 volt battery is disconnected and then reconnected, and/or when the fuse is removed.

Figure 3-10 illustrates an engine speed profile during a typical exercise cycle. **Table 3-1** details exercise information and programming options for all home standby generators.

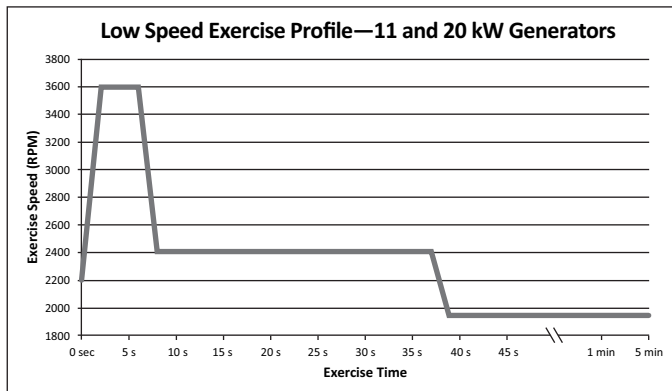

008589

Figure 3-10. Low Speed Exercise Profile

NOTE: If Quiet Test is disabled, the generator will exercise at the rated rpm.

Table 3-1. Generator Exercise Characteristics

| Generator Size | 11 and 20 kW |
|----------------------------|--------------------------|
| Low Speed Exercise | 1950 rpm |
| Exercise Frequency Options | Weekly/Bi-Weekly/Monthly |
| Exercise Time Length | 5 minutes |

Battery Charger

IMPORTANT NOTE: Contact an IASD if the controller screen displays “CHARGER MISSING AC.”

NOTE: The battery charger is integrated into the control module in all models.

The battery charger operates as a smart charger which verifies:

- output is continually optimized to promote maximum battery life.
- charging levels are safe.

NOTE: A warning is displayed on the LCD when the battery needs service.

NOTE: Do not use external battery chargers.

Manual Transfer Operation



⚠ DANGER

Electrocution. Do not manually transfer under load. Disconnect transfer switch from all power sources prior to manual transfer. Failure to do so will result in death or serious injury, and equipment damage. (000132)

Prior to automatic operation, manually exercise the transfer switch to verify there is no interference with proper operation of the mechanism. Manual operation of the transfer switch is required if electronic operation should fail.

Transfer to Generator Power Source

1. Verify generator is OFF.
2. Set main line circuit breaker (MLCB) (generator disconnect) to OFF (OPEN).
3. Turn OFF utility power supply to the transfer switch using the means provided (such as a main line utility breaker).
4. See **Figure 3-11**. Use the manual transfer handle (A) inside the transfer switch to move the main contacts to STANDBY (loads connected to the standby power source).
5. Press control panel MANUAL mode button to crank and start the engine.
6. Allow engine to stabilize and warm up for a few minutes.
7. Set MLCB (generator disconnect) to ON (CLOSED). The standby power source now powers the loads.

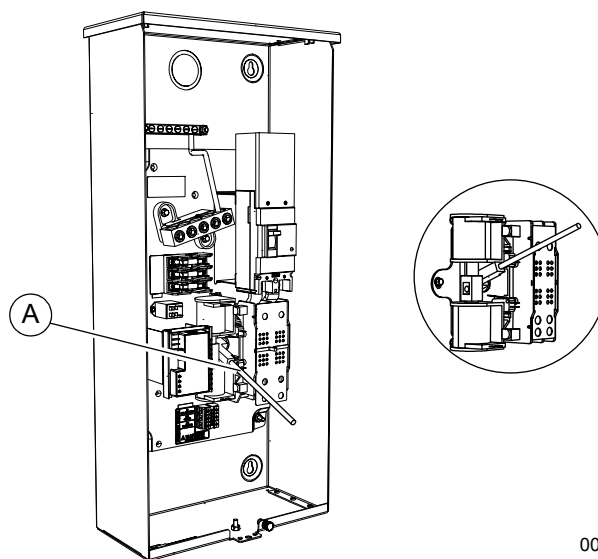

002565

Figure 3-11. Typical Manual Transfer Switch Operation

| | |
|----------|---|
| MANUAL | <ul style="list-style-type: none"> • Will not transfer to generator if utility is present. • Will transfer to generator if utility drops (below 65% of nominal for five consecutive seconds; dealer programmable) after warm-up. • Will transfer back when utility returns for 15 consecutive seconds (dealer programmable). The engine will continue to run until removed from MANUAL mode. |
| AUTO | <ul style="list-style-type: none"> • Will start and run if utility drops for five consecutive seconds (dealer programmable). • Will start an engine warm-up timer (duration varies when Cold Smart Start is enabled). <ul style="list-style-type: none"> –Will not transfer if utility subsequently returns. –Will transfer to generator if utility is not present. • Will transfer to utility once utility returns (above 80% of nominal) for 15 consecutive seconds (dealer programmable). • Will not transfer to utility unless utility returns. The generator will shut down if the OFF mode button is pressed or a shutdown alarm is present. • Once utility power is returned, the generator will shut down after one minute cool-down time. |
| EXERCISE | <ul style="list-style-type: none"> • Will not exercise if generator is already running in either AUTO or MANUAL mode. • During exercise, the controller will only transfer if utility drops during exercise for five seconds (dealer programmable), and will switch to AUTO. |

Transfer to Utility Power Source

Shut down generator and transfer to utility source after utility power has been restored. Proceed as follows to manually transfer to utility power and shut down the generator:

1. Set the MLCB (generator disconnect) to OFF (OPEN).
2. Run engine for one minute at no-load to stabilize the internal temperature.
3. Press the OFF mode button on the control panel. The engine will shut down.
4. Verify utility power supply to the transfer switch is turned OFF.
5. Move the main contacts to the UTILITY position (loads connected to the utility power source) using the manual transfer handle inside the transfer switch.
6. Turn on the utility power supply to the transfer switch using the means provided.
7. Press the AUTO mode button on the control panel.
8. Return the MLCB (generator disconnect) to ON (CLOSED).
9. Close and lock the lid.

Automatic Transfer Operation

Proceed as follows to select automatic operation:

1. Verify transfer switch main contacts are set to UTILITY (loads connected to the utility power source).
2. Verify normal utility power source voltage is available to loads connected to the transfer switch.
3. Press the AUTO mode button on the generator control panel.
4. Set MLCB (generator disconnect) to ON (CLOSED).

The generator will start automatically when utility source voltage drops below a preset level. Loads are transferred to standby power source after the unit starts.

Automatic Sequence of Operation

Utility Failure

If the generator is set to AUTO, when utility fails (below 65% of nominal) a five second (dealer programmable) line interrupt delay time is started. The engine cranks and starts if utility power is still unavailable when the timer expires. An engine warm-up timer will be initiated once the engine is started. Timer duration varies depending on whether or not **Cold Smart Start** is enabled. The controller will transfer the load to the generator when the warm-up time expires. If the utility power is restored (above 80% nominal) at any time from the initiation of the engine start until the generator is ready to accept load (warm-up time has not elapsed), the controller completes the start cycle and runs the generator through its normal cool down cycle. However, the load will remain on the utility source.

Cranking

The system will control the cyclic cranking as follows:

- **11 and 20 kW Units:** five cranking cycles as follows: 16 seconds cranking, 7 seconds resting, 16 seconds cranking, 7 seconds resting, followed by three additional cycles of 7 seconds cranking followed by 7 seconds resting.

NOTE: An alarm will be triggered if the generator does not start after these five attempts.

Cold Smart Start

The generator will monitor ambient temperature when Cold Smart Start is enabled. The warm-up delay will be adjusted based on prevailing conditions. Cold Smart Start is enabled at the factory, but can be disabled in the EDIT menu.

See [Table 3-2](#). If the ambient temperature is below a fixed temperature (based on model) upon startup in AUTO mode, the generator will warm up for 30 seconds. This allows the engine to warm before a load is applied. The generator will startup with the normal warm-up delay of five seconds if the ambient temperature is at or above the fixed temperature.

| Generator Size | 11 kW and 20 kW |
|-------------------|-----------------|
| Fixed Temperature | 50 °F (10 °C) |

A check for proper output voltage buildup will be performed when the generator engine is started.

If some condition impedes normal voltage creation, such as frost crystals or dust/dirt preventing a good electrical connection, the start sequence will be interrupted so a cleaning cycle of the internal electrical connections can be attempted.

The cleaning cycle is an extended warming up period which lasts for several minutes while the normal generator voltage output is determined to be low. During this cycle, the generator controller will display “Warming Up” on the display screen.

The generator controller display will show “Under Voltage” if the cleaning cycle fails to clear the obstruction. After several minutes, the alarm message can be cleared, and the generator restarted.

If the problem persists, make no further attempts to start. Contact an IASD.

Load Transfer

The transfer of load when the generator is running is dependent upon the operating mode.

Shutting Generator Down While Under Load or During a Utility Outage

⚠ DANGER

Automatic start-up. Disconnect utility power and render unit inoperable before working on unit. Failure to do so will result in death or serious injury.

(000191)

IMPORTANT NOTE: To avoid equipment damage, follow these steps, in order, during utility outages. Shutdowns may be required during utility outages to perform routine maintenance or to conserve fuel.

To turn the generator OFF:

1. Set the main utility disconnect to OFF (OPEN).
2. Set the generator MLCB (generator disconnect) to OFF (OPEN).
3. Allow the generator to run for a cool-down period of approximately one minute.
4. At the controller, set the generator to OFF.
5. Remove the 7.5A fuse from the controller.

To turn the generator back ON:

1. Install 7.5A fuse in controller.
2. Confirm the generator MLCB (generator disconnect) is OFF (OPEN).
3. At the controller, set the generator to AUTO mode.
4. Generator will start and run. Allow generator to run and warm up for a few minutes.
5. Set the MLCB (generator disconnect) to ON (CLOSED).
6. Set the main utility disconnect to ON (CLOSED).

The system now operates in automatic mode.

This page intentionally left blank.

Section 4: Maintenance

Maintenance

Regular maintenance will improve performance and extend engine/equipment life. The manufacturer recommends that all maintenance work be performed by an Independent Authorized Service Dealer (IASD). Regular maintenance, replacement or repair of the emissions control devices and systems may be performed by any repair shop or person of the owner's choosing. However, to obtain emissions control warranty service free of charge, the work must be performed by an IASD. See the emissions warranty.

WARNING

Equipment damage. Only qualified service personnel may install, operate, and maintain this equipment. Failure to follow proper installation requirements could result in death, serious injury, and equipment or property damage.

(000182a)

Preparing for Maintenance

DANGER

Automatic start-up. Disconnect utility power and render unit inoperable before working on unit. Failure to do so will result in death or serious injury.

(000191)

1. Set main utility disconnect to OFF (OPEN).
2. Lift lid and set MLCB (generator disconnect) on generator to OFF (OPEN).
3. Allow generator to run and cool down for one minute with no load (if running during a utility outage).
4. Press OFF mode button on controller.
5. Remove 7.5 A fuse from control panel.
6. Remove front panel and intake side panel.

Performing Scheduled Maintenance

It is important to perform maintenance as specified in the [Service Schedule](#) for proper generator operation. Engine oil and oil filter must be changed, and valve clearance adjusted after the first 25 hours of operation.

Emissions-critical maintenance must be performed as scheduled in order for the emissions warranty to be valid. Emissions-critical maintenance consists of servicing the air filter and spark plug(s) in accordance with the [Service Schedule](#).

The controller will prompt for Schedule A or Schedule B maintenance to be performed. Schedule A maintenance consists of the oil, oil filter, and battery check. Schedule B maintenance includes the oil, oil filter, battery check, air cleaner, spark plug(s), and valve clearance.

Since most maintenance alerts occur at the same time (most have two year intervals), only one will appear on the control panel display at a time. Once the first alert is cleared, the next active alert will be displayed.

Service Schedule

| Service | Daily If Running Continuously or Before Each Use | Every Year | Schedule A Every Two Years or 200 Hours | Schedule B Every Four Years or 400 Hours |
|--|--|------------|---|--|
| Inspect enclosure louvers for dirt and debris * | • | | | |
| Inspect lines and connections for fuel or oil leaks | • | | | |
| Inspect engine oil level | • | | | |
| Check for water intrusion ** | | • | | |
| Perform fuel system leak test | | • | | |
| Check battery condition, electrolyte level, and state of charge | | • | • | • |
| Replace engine oil and oil filter † | | | • | • |
| Replace engine air filter | | | | • |
| Clean; inspect spark plug gap; replace if necessary | | | | • |
| Inspect/adjust valve clearance ‡ | | | | • |
| Inspect/clean sediment trap | <i>Consult local codes and guidelines.</i> | | | |
| <p>Contact the nearest IASD for assistance if necessary.</p> <p>* Remove any shrubs or tall grasses which have grown within 3 ft (0.91 m) of intake and discharge louvers on enclosure sides. Clean any debris (dirt, grass clippings, etc.) which may have accumulated inside the enclosure.</p> <p>** Verify all sources of potential water intrusion such as water sprinklers, roof run-off, rain gutter downspouts, and sump pump discharges are directed away from generator enclosure.</p> <p>† Change engine oil and filter after the first 25 hours of operation. In cold weather conditions (ambient below 40 °F [4.4 °C]), or if unit is operated continuously in hot weather conditions (ambient above 85 °F [29.4 °C]), change engine oil and filter every year or 100 hours of operation.</p> <p>‡ Check/adjust valve clearance after the first 25 hours of operation.</p> | | | | |

NOTE: Contact an IASD or visit www.drpower.com for additional information on replacement parts.

Maintenance Log

Battery Inspection and Charge Check

Dates Performed:

| | | | | | | | | | |
|--|--|--|--|--|--|--|--|--|--|
| | | | | | | | | | |
| | | | | | | | | | |
| | | | | | | | | | |

Oil, Oil Filter, Air Filter, and Spark Plug Replacement

Dates Performed:

| | | | | | | | | | |
|--|--|--|--|--|--|--|--|--|--|
| | | | | | | | | | |
| | | | | | | | | | |
| | | | | | | | | | |

Valve Adjustment

Dates Performed:

| | | | | | | | | | |
|--|--|--|--|--|--|--|--|--|--|
| | | | | | | | | | |
| | | | | | | | | | |
| | | | | | | | | | |

Checking Engine Oil Level



⚠ WARNING

Risk of burns. Allow engine to cool before draining oil or coolant. Failure to do so could result in death or serious injury.

(000139)

⚠ WARNING

Skin irritation. Avoid prolonged or repeated contact with used motor oil. Used motor oil has been shown to cause skin cancer in laboratory animals. Thoroughly wash exposed areas with soap and water.

(000210)

⚠ CAUTION

Engine damage. Verify proper type and quantity of engine oil prior to starting engine. Failure to do so could result in engine damage.

(000135)

IMPORTANT NOTE: Check oil level daily when power outages necessitate running the generator for extended periods.

Proceed as follows to check engine oil level:

1. Set main utility disconnect to OFF (OPEN).
2. Set main line circuit breaker (MLCB) (generator disconnect) on generator to OFF (OPEN).
3. Run generator for a cool-down period of approximately one minute.
4. Press OFF mode button to turn generator off. Wait five minutes.
5. Remove oil dipstick and wipe it dry with a clean cloth.
6. Completely insert oil dipstick into oil dipstick tube and remove it.
7. Observe oil level. The level should be at the "FULL" mark on oil dipstick.
8. If necessary, remove oil fill cap and add oil to engine (with oil dipstick removed) until level reaches "FULL" mark. Insert oil dipstick and install fill cap.

To restart the generator:

1. Press the control panel AUTO mode button.
2. Allow the generator to start and warm up for a few minutes.
3. Set the generator disconnect on the generator to ON (CLOSED).
4. The system is now operating in automatic mode. The main utility disconnect can be turned ON (CLOSED).

Engine Oil Requirements

To maintain the product warranty, the engine oil should be serviced in accordance with the recommendations of this manual. For your convenience, maintenance kits are available consisting of engine oil, oil filter, air filter, spark plug(s), a shop towel, and a funnel. These kits can be obtained from an IASD.

All oil kits meet minimum American Petroleum Institute (API) Service Class SJ, SL, or better. Do not use special additives.

Required Oil

Synthetic SAE 5W-30 for all temperature ranges. See [Engine](#) in General Information.

⚠ CAUTION

Engine damage. Verify proper type and quantity of engine oil prior to starting engine. Failure to do so could result in engine damage.

(000135)

Changing the Oil and Oil Filter

Proceed as follows to change the oil and oil filter:

1. Lift the lid and press the MANUAL mode button on the control panel to start the engine, and run it until it is thoroughly warmed up. Press the OFF mode button on the control panel to shut down the engine.
2. See [Figure 4-1](#). A few minutes after the engine stops, and when it has cooled slightly, remove the front panel. Pull the oil drain hose (A) free of its retaining clip. Remove the cap from the hose and drain the oil into a suitable container.

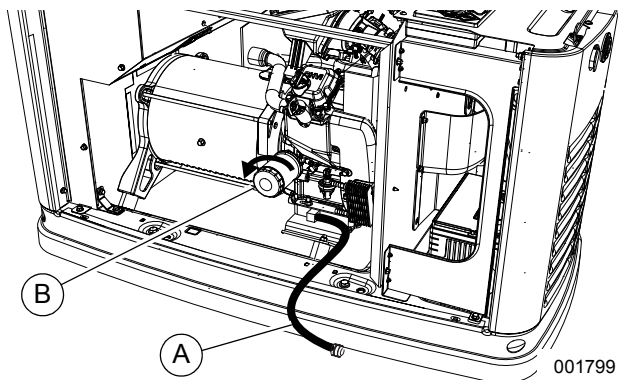

Figure 4-1. Oil Filter and Drain Location (11 kW and 20 kW)

3. Install the cap on the hose. Position and secure the hose with the retaining clip.
4. Remove oil filter (B) by turning it counterclockwise.
5. Apply a light coating of clean engine oil to the gasket of the new filter.
6. Screw the new filter on by hand until its gasket lightly contacts the oil filter adapter. Tighten the filter an additional three-quarter to one full turn.
7. Fill the engine with the proper recommended oil. See [Engine Oil Requirements](#).
8. Press the MANUAL mode button on the control panel to start the engine. Run for one minute, and check for leaks.
9. Press the OFF mode button on the control panel to stop the engine. Wait five minutes.
10. Inspect the oil level. Add oil as needed. **DO NOT OVERFILL.**
11. Insert oil dipstick and/or attach fill cap.
12. Press AUTO mode button on the control panel to return the unit to AUTO mode.
13. Close and lock the lid.
14. Dispose of the used oil and filter at a proper collection center.

Servicing the Air Cleaner

Proceed as follows to service the air cleaner:

1. Lift the lid and press the OFF mode button on the control panel to stop the generator. Remove the front panel.
2. See [Figure 4-2](#). Remove the cover clips (A) and air cleaner cover (B).

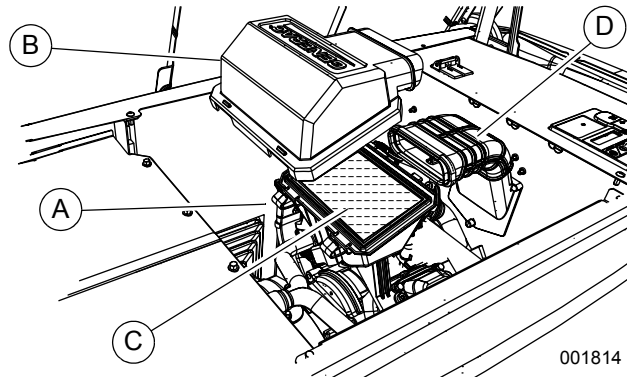

Figure 4-2. Servicing Air Cleaner (11 kW and 20 kW)

3. Remove the old air filter element (C) and discard.
4. Thoroughly clean the air cleaner enclosure of any dust or debris.
5. Install a new air filter element.
6. Install the air cleaner cover and fasten the cover clips.
7. Verify air inlet duct (D) is properly connected to the air cleaner cover.
8. Press the AUTO mode button on the control panel to return the unit to AUTO mode.

Spark Plug(s)

Proceed as follows to inspect spark plug gap(s) and replace spark plug(s) as necessary:

1. With the generator OFF and the engine cool, lift the lid and remove the front panel.
2. Clean the area around the base of the spark plug(s) to keep dirt and debris out of the engine.
3. Remove spark plug(s) and inspect the condition. Install new plug(s) if existing plug(s) is worn or if reuse is questionable.
4. Clean plug(s) by scraping or washing with a wire brush and commercial solvent. Do not blast plug(s) to clean.

NOTE: Clean spark plug in emergency situations only. Otherwise, replace spark plug.

5. Inspect spark plug gap using a wire feeler gauge. See [Figure 4-3](#). Replace spark plug if gap is out of specification. See [General Information](#).

NOTE: New spark plugs should have the gap checked prior to installation.

6. Install the spark plug(s), and torque to 18.4 ft-lbs (25 Nm).
7. Press the control panel AUTO button to return the unit to AUTO mode.

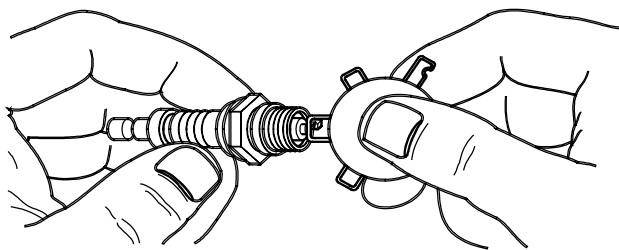

000211

Figure 4-3. Spark Plug Gap Measurement

Valve Clearance Adjustment

IMPORTANT NOTE: Contact an IASD for service assistance. Proper valve clearance is essential for prolonging the life of the engine.

Check valve clearance after the first 25 hours of operation, then after 400 hour intervals. Adjust if necessary.

Check Valve Clearance

NOTE: The engine should be cool before checking valve clearance. Adjustment is not needed if valve clearance is within the dimensions provided in [Engine](#).

1. Close fuel valve and disconnect battery to avoid accidental start-up.
2. Remove spark plug wire(s), and position wire(s) away from plug(s).
3. Remove spark plug(s).
4. Remove the four screws attaching the valve cover. Remove and discard the gasket. (Repeat for second cylinder, if equipped.)
5. Verify piston is at top dead center (TDC) of its compression stroke (both valves closed). To move the piston to TDC, remove the intake baffle at the front of the engine to access the flywheel nut. Use a large socket and socket wrench to rotate the flywheel nut clockwise, which will rotate the crankshaft. Watch the piston through the spark plug hole. The piston should move up and down. The piston is at TDC when it is at its highest point of travel.
6. See [Figure 4-4](#). Check the valve clearance between each rocker arm (E) and valve stem (F) with a feeler gauge.

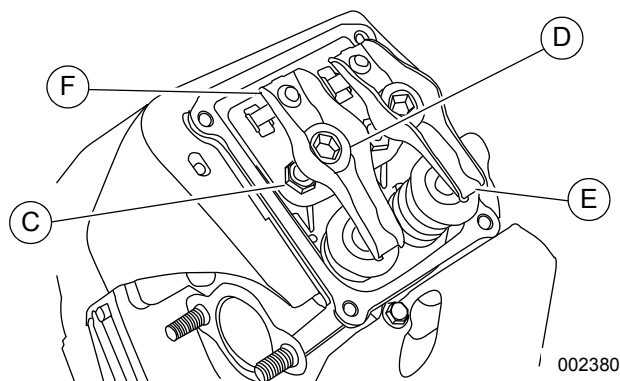

002380

Figure 4-4. Valve Clearance Adjustment (11 kW and 20 kW)

7. Install replacement valve cover gasket(s).
8. Install valve cover(s). Tighten fasteners in a cross pattern, torquing to:

| | |
|--------------|-------------------|
| 11 and 20 kW | 60 in-lb (6.8 Nm) |
|--------------|-------------------|

Adjust Valve Clearance

See **Figure 4-4**. Proceed as follows to adjust valve clearance:

NOTE: Allow engine to cool before adjusting valve clearance.

1. Remove spark plug wire(s) and position wire(s) away from plugs.
2. Remove spark plug(s).
3. Remove four screws attaching valve cover. Remove and discard gasket.
4. Verify piston is at top dead center (TDC) of its compression stroke (both valves closed).
5. Loosen rocker jam nut (C) using a 10 mm wrench (11 kW units) or 13 mm wrench (20 kW units.)
6. Turn pivot ball stud (D) using an 8 mm wrench (11 kW units) or 10 mm hex key (20 kW units) while checking clearance between rocker arm (E) and valve stem (F) with a feeler gauge. Adjust clearance as per **Engine**.

NOTE: Hold the rocker jam nut in place as the pivot ball stud is turned.

7. When valve clearance is correct, hold pivot ball stud (D) in place with a wrench and tighten rocker arm jam nut. Tighten jam nut according to the following torque specifications:

| | |
|-------|----------------------|
| 11 kW | 72 in-lb (8.2 Nm) |
| 20 kW | 174 in-lb (19.68 Nm) |

8. After tightening jam nut, inspect valve clearance to verify it did not change.
9. Install new valve cover gasket.
10. Install the valve cover. Tighten fasteners in a cross pattern, torquing to:

| | |
|--------------|-------------------|
| 11 and 20 kW | 60 in-lb (6.8 Nm) |
|--------------|-------------------|

NOTE: Start all four screws before tightening, or it will not be possible to get all the screws in place. Verify the valve cover gasket is in place.

11. Install spark plugs and tighten to 18 ft-lbs (25 Nm).
12. Attach the spark plug wire to the spark plug.
13. Repeat the process for the other cylinder if equipped.

Battery Maintenance



DANGER

Electrocution. Do not wear jewelry while working on this equipment. Doing so will result in death or serious injury.

(000188)



WARNING

Explosion. Do not dispose of batteries in a fire. Batteries are explosive. Electrolyte solution can cause burns and blindness. If electrolyte contacts skin or eyes, flush with water and seek immediate medical attention.

(000162)



WARNING

Explosion. Batteries emit explosive gases while charging. Keep fire and spark away. Wear protective gear when working with batteries. Failure to do so could result in death or serious injury.

(000137a)



WARNING

Electrical shock. Disconnect battery ground terminal before working on battery or battery wires. Failure to do so could result in death or serious injury.

(000164)



WARNING

Risk of burns. Batteries contain sulfuric acid and can cause severe chemical burns. Wear protective gear when working with batteries. Failure to do so could result in death or serious injury.

(000138a)



WARNING

Risk of burn. Do not open or mutilate batteries. Batteries contain electrolyte solution which can cause burns and blindness. If electrolyte contacts skin or eyes, flush with water and seek immediate medical attention.

(000163a)

WARNING

Environmental Hazard. Always recycle batteries at an official recycling center in accordance with all local laws and regulations. Failure to do so could result in environmental damage, death or serious injury.

(000228)

Always recycle batteries in accordance with local laws and regulations. Contact your local solid waste collection site or recycling facility to obtain information on local recycling processes. For more information on battery recycling, visit the Battery Council International website at: <http://batteryCouncil.org>

Strictly observe the following precautions when working on batteries:

- Remove the 7.5 A fuse from the generator control panel.
- Disconnect the battery charger as directed in [Battery Maintenance](#).
- Use tools with insulated handles.
- Wear rubber gloves and boots.
- Do not place tools or metallic objects on top of the battery.
- Disconnect the charging source prior to connecting or disconnecting battery terminals.
- Wear full eye protection and protective clothing.
- If electrolyte contacts the skin, wash it off immediately with water.
- If electrolyte contacts the eyes, immediately thoroughly flush with water and seek medical attention.
- Wash down spilled electrolyte with an acid neutralizing agent. A common practice is to use a solution of 1 lb (454 g) bicarbonate of soda to 1 gal (3.8 L) of water. Add bicarbonate of soda solution until the evidence of reaction (foaming) has ceased. Flush the resulting liquid with water and dry the area completely.
- DO NOT smoke near the battery.
- DO NOT cause flame or spark in the battery area.
- Discharge static electricity from the body before touching the battery by first touching a grounded metal surface.

The battery should be regularly inspected per the [Service Schedule](#). Contact an IASD for assistance if necessary.

Proceed as follows to inspect the battery:

1. Press the OFF mode button to shut down the generator, then lift the lid and remove the front panel.
2. Remove the 7.5 A fuse from the control panel.
3. Remove the intake side panel. (See [Intake Side Panel Removal](#).)
4. See [Figure 4-5](#). Inspect battery posts and cables for tightness and corrosion. Tighten and clean as necessary.

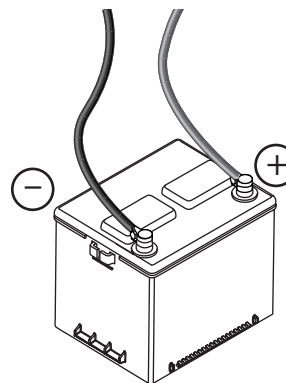

001832

Figure 4-5. Battery Cables

5. Unsealed batteries only: Completely disconnect the battery. Check the battery fluid level and, if necessary, fill with distilled water only. DO NOT use tap water. Also, have an IASD or a qualified service technician check the state of charge and condition.
6. When inspection is complete, connect the battery cables, install the intake side panel, and install the 7.5 A fuse.
7. Place the generator in auto by pressing the AUTO mode button on the controller.
8. Install front panel and close generator lid.

Cleaning the Sediment Trap

The sediment trap removes contaminants (moisture and fine particles) from gaseous fuels before they enter the fuel regulator. Accumulated moisture and particles must be emptied from the sediment trap per local codes and guidelines.

Proceed as follows to clean the sediment trap:

1. Remove intake side panel (see [Intake Side Panel Removal](#)).
2. Turn the generator fuel supply OFF.
3. See [Figure 4-6](#). Unscrew and remove cap (A).

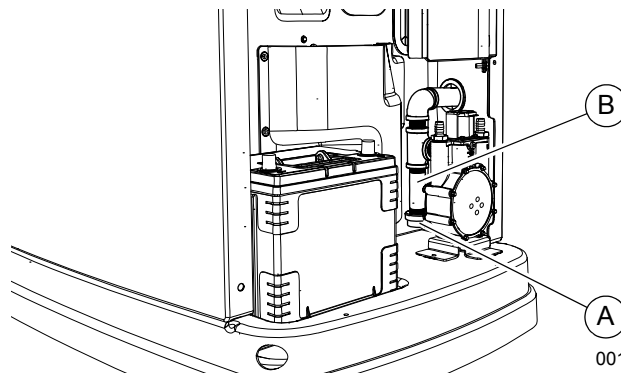

001821

Figure 4-6. Cleaning the Sediment Trap

4. Use a clean-out tool (not provided) to remove accumulated moisture and particles from cap and body (B).
5. Wipe the inside of each component with a clean, dry, lint-free cloth.
6. Seal the threads of the cap with appropriate sealing compound. Install the cap and hand-tighten.
7. Tighten the cap with an appropriately sized pipe wrench. DO NOT overtighten.
8. Turn the generator fuel supply on. Check for leaks by spraying all connection points with a non-corrosive gas leak detection fluid. The solution should not be blown away or form bubbles.
9. Install the intake side panel.

Post Maintenance Checks

1. Perform required maintenance procedure(s).
2. Install the intake side panel and front panel if removed. (See [Intake Side Panel Removal](#) and [Removing the Front Access Panel](#).)
3. Install the 7.5 A fuse in the control panel.
4. Complete the Installation Wizard information.
5. Press the AUTO mode button on the control panel. Allow the unit to run for one minute with no load (if running during a utility outage).
6. Set the MLCB (generator disconnect) on the generator to ON (CLOSED).
7. Turn the main utility disconnect ON (CLOSED).

The system is now in automatic mode.

NOTE: If proper utility is present at this time, the generator will perform its usual shutdown process.

Perform Leak Test



⚠ DANGER

Explosion and fire. Fuel and vapors are extremely flammable and explosive. No leakage of fuel is permitted. Keep fire and spark away. Failure to do so will result in death or serious injury. (000192)

All products are tested at the factory before shipping to ensure the performance and integrity of the fuel system. However, it is important to perform a final fuel system leak test before starting the generator. The entire fuel system should be tested from supply to regulator.

See [Figure 4-7](#). Perform a final fuel system leak test after generator installation. The test will identify possible leaks at all connection points (A).

It is best practice to perform a fuel system leak test during normally-scheduled maintenance.

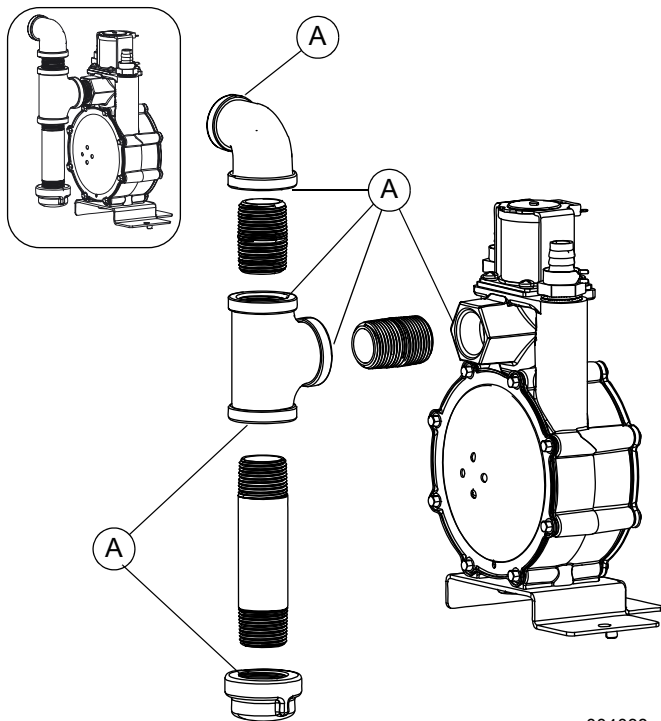

004038

Figure 4-7. Connection Points to Leak Check

Check for leaks by spraying all connection points with a non-corrosive gas leak detection fluid. The solution should not be blown away or form bubbles.

Attention After Submersion

DO NOT start or operate the generator if it has been submerged in water. Have an IASD thoroughly clean, dry, and inspect the generator following any submersion in water. If the structure (home) has been flooded, it should be inspected by a certified electrician to verify there will not be any electrical problems during generator operation or when utility power is returned.

Corrosion Protection

Regular scheduled maintenance should be conducted to perform a visual inspection of the unit for corrosion. Inspect all metal components of the generator, including the base frame, brackets, alternator can, the entire fuel system (inside and outside of the generator), and fastener locations. If there is corrosion found on generator components (e.g. regulator, engine/alternator mounts, fuel plenum, etc.), replace parts as necessary.

Periodically wash and wax the enclosure using automotive type products. Do not spray the unit with a hose or power washer. Use warm, soapy water and a soft cloth. Frequent washing is recommended in salt water/coastal areas. Spray engine linkages with a light oil such as WD-40®.

Remove From, and Return To Service Procedure

Remove From Service

If the generator cannot be exercised monthly, at a minimum, and will be out of service longer than 90 days, proceed as follows to prepare the generator for storage:

1. Start engine and allow it to warm up.
2. Close fuel shutoff valve in the fuel supply line and allow engine to stop.
3. Once the engine has stopped, set the generator MLCB (generator disconnect) to OFF (OPEN).
4. Disconnect battery charger AC input T1/Neutral cable (with white sleeve) at controller.
5. Remove 7.5 A fuse from the generator control panel.
6. Disconnect battery cables. Remove the negative cable first.



⚠ WARNING

Explosion. Batteries emit explosive gases. Always disconnect negative battery cable first to avoid spark. Failure to do so could result in death or serious injury. (000238)

7. Drain oil completely while the engine is still warm, and then fill crankcase with oil. See [Engine Oil Requirements](#).
8. Attach a tag to the engine indicating the viscosity and classification of the new oil in the crankcase.
9. Remove spark plug(s) and spray a fogging agent into spark plug(s) threaded openings. Install and tighten spark plug(s) to specification.
10. Remove battery and store in a cool, dry place.
11. Clean and wipe down the generator enclosure.

Return to Service

Proceed as follows to return the unit to service after storage:

1. Check the tag on the engine for oil viscosity and classification. Drain and fill with proper oil, if necessary.
2. Check the state of the battery. Fill all cells of unsealed batteries to the proper level with distilled water. DO NOT use tap water. Recharge the battery to 100% state of charge. Replace the battery if defective.
3. Clean and wipe down the generator enclosure.
4. Verify 7.5 A fuse is removed from generator control panel.



⚠ WARNING

Explosion. Batteries emit explosive gases. Always connect positive battery cable first to avoid spark. Failure to do so could result in death or serious injury. (000133)

5. Connect battery. Observe battery polarity. Damage may occur if the battery is connected incorrectly. Install positive cable first.
6. Connect battery charger AC input T1/Neutral cable (with white sleeve) at controller.
7. Open the fuel shutoff valve.
8. Insert 7.5 A fuse into the generator control panel.
9. Complete the Installation Wizard procedure (diagrammed in the generator installation manual).
10. Press the MANUAL mode button to start the unit. Allow the unit to warm up for a few minutes.
11. Press the control panel OFF mode button to stop the unit.
12. Set the MLCB (generator disconnect) to ON (CLOSED).
13. Press the AUTO mode button on the control panel.

The generator is ready for service.

NOTE: The exercise timer and current date and time must be reset if a battery has been completely discharged or disconnected.

Section 5: Troubleshooting / Quick Reference Guide

Generator Troubleshooting

| Problem | Cause | Correction |
|---|--|--|
| Engine will not crank. | Blown fuse. | Correct short circuit condition by replacing 7.5 A fuse in generator control panel. Contact an Independent Authorized Service Dealer (IASD) if fuse continues to blow. |
| | Loose, corroded, or defective battery cables. | Tighten, clean, or replace as necessary.* |
| | Defective starter contact. | Tighten, clean, or replace as necessary.* |
| | Defective starter motor. | Tighten, clean, or replace as necessary.* |
| | Discharged battery. | Charge or replace battery. |
| Engine cranks but will not start. | No fuel. | Replenish fuel / turn on fuel valve. |
| | Defective fuel solenoid (FS). | Replenish fuel / turn on fuel valve. |
| | Open Wire 14 from controller. | Replenish fuel / turn on fuel valve. |
| | Defective spark plug(s). | Clean; inspect gap; replace plug(s) if necessary. |
| | Valve clearance out of adjustment. | Reset valve clearance |
| Engine starts hard and runs rough. | Air cleaner plugged or damaged. | Inspect and clean air cleaner. |
| | Defective spark plug(s). | Clean; inspect gap; replace plug(s) as needed. |
| | Incorrect fuel pressure. | Confirm fuel pressure to regulator is 10–12 in water column (19–22 mm Hg) for LP, and 3.5–7.0 in water column (7–13 mm Hg) for natural gas. |
| | Fuel selector in wrong position. | Turn fuel conversion valve to correct position. |
| | Valve(s) out of adjustment. | Adjust valve clearance. |
| | Internal engine issue. | Contact an IASD for assistance. |
| Generator is set to OFF, but the engine continues to run. | Controller wired incorrectly. | Contact an IASD for assistance. |
| | Defective control board. | Contact an IASD for assistance. |
| No AC output from generator. | Main line circuit breaker (MLCB) (generator disconnect) is OFF (OPEN). | Reset generator disconnect to ON (CLOSED). |
| | Generator internal failure. | Contact an IASD for assistance. |
| | Engine may be warming up. Refer to Cold Smart Start | Check the controller screen to verify status. |

| Problem | Cause | Correction |
|--|---|---|
| No transfer to standby after utility source failure. | MLCB (generator disconnect) is OFF (OPEN). | Reset generator disconnect to ON (CLOSED). |
| | Defective transfer switch coi | Contact an IASD for assistance |
| | Defective transfer relay. | Contact an IASD for assistance |
| | Transfer relay circuit open. | Contact an IASD for assistance |
| | Defective control logic board. | Contact an IASD for assistance |
| | Engine may be warming up. Refer to Cold Smart Start . | Check the controller screen to verify status. |
| Unit consumes large amounts of oil. | Excessive engine oil. | Adjust oil to proper level. |
| | Defective engine breather. | Contact an IASD for assistance |
| | Improper type or viscosity of oil | See Engine Oil Requirements . |
| | Damaged gasket, seal, or hose. | Check for oil leaks. |
| | Restricted air filter. | Replace air filter. |
| * Contact an IASD for assistance. | | |

Quick Reference Guide

To clear an active alarm, press the OFF mode button on the control panel, then the ENTER button, and finally the AUTO mode button. Contact an IASD if the alarm reoccurs.

| Active Alarm | LED | Problem | Things to Check | Solution |
|-----------------------|----------------|--|--|---|
| NONE | FLASHING GREEN | Unit running in AUTO but no power in house. | Check MLCB. | Check MLCB. If it is ON, contact an IASD. |
| HIGH TEMPERATURE | RED | Unit shuts down during operation. | Check the LEDs / screen for alarms. | Check ventilation around the generator, intake, exhaust, and rear of generator. If no obstructions are present, contact an IASD. |
| OVERLOAD REMOVE LOAD | RED | Unit shuts down during operation. | Check the LEDs / screen for alarms. | Clear alarm and remove household loads from the generator. Put in AUTO and restart. |
| RPM SENSE LOSS | RED | Unit was running and shut down, attempts to restart. | Check the LEDs / screen for alarms. | Clear alarm and remove household loads from the generator. Put into AUTO and restart. If generator does not start, contact an IASD. |
| NOT ACTIVATED | NONE | Unit will not start in AUTO with utility loss. | Check if screen says unit not activated. | Refer to "Activation" in installation manual. |
| NONE | GREEN | Unit will not start in AUTO with utility loss. | Check screen for start delay countdown. | If the startup delay is greater than expected, contact an IASD to adjust from 2 to 1500 seconds. |
| LOW OIL PRESSURE | RED | Unit will not start in AUTO with utility loss. | Check the LEDs / screen for alarms. | Check oil level and add oil as needed. If oil level is correct, contact an IASD. |
| RPM SENSE LOSS | RED | Unit will not start in AUTO with utility loss. | Check the LEDs / screen for alarms. | Clear alarm. Using the control panel, check the battery by navigating to the BATTERY MENU option from the MAIN MENU. If battery condition displays GOOD, contact an IASD. If control panel displays CHECK BATTERY, replace the battery. |
| OVERCRANK | RED | Unit will not start in AUTO with utility loss. | Check the LEDs / screen for alarms. | Check fuel line shutoff valve is ON. Clear alarm. Start the unit in MANUAL. If it does not start, or starts and runs rough, contact an IASD. |
| LOW VOLTS REMOVE LOAD | RED | Unit will not start in AUTO with utility loss. | Check the LEDs / screen for alarms. | Clear alarm and remove household loads from the generator. Put in AUTO and restart. |
| OVERSPEED | RED | Unit will not start in AUTO with utility loss. | Check the LEDs / screen for alarms. | Contact an IASD. |
| UNDERVOLTAGE | RED | Unit will not start in AUTO with utility loss. | Check the LEDs / screen for alarms. | Contact an IASD. |
| UNDERSPEED | RED | Unit will not start in AUTO with utility loss. | Check the LEDs / screen for alarms. | Contact an IASD. |
| STEPPER OVERCURRENT | RED | Unit will not start in AUTO with utility loss. | Check the LEDs / screen for alarms. | Contact an IASD. |
| MISWIRE | RED | Unit will not start in AUTO with utility loss. | Check the LEDs / screen for alarms. | Contact an IASD. |

| Active Alarm | LED | Problem | Things to Check | Solution |
|--------------------|--------|--|--|---|
| OVERVOLTAGE | RED | Unit will not start in AUTO with utility loss. | Check the LEDs / screen for alarms. | Contact an IASD. |
| AUXILIARY SHUTDOWN | RED | Unit will not start. | Check auxiliary shutdown switches | Set auxiliary shutdown switch(es) to CLOSED (I). Clear alarm. |
| LOW BATTERY | YELLOW | Yellow LED illuminated in any state. | Check the screen for additional information. | Clear alarm. Using the control panel, check the battery by navigating to the BATTERY MENU option from the MAIN MENU. If battery condition displays GOOD, contact an IASD. If control panel displays CHECK BATTERY, replace the battery. |
| BATTERY PROBLEM | YELLOW | Yellow LED illuminated in any state. | Check the screen for additional information. | Contact an IASD. |
| CHARGER WARNING | YELLOW | Yellow LED illuminated in any state. | Check the screen for additional information. | Contact an IASD. |
| CHARGER MISSING AC | YELLOW | Yellow LED illuminated in any state. | Check the screen for additional information. | Contact an IASD. |
| SERVICE A | YELLOW | Yellow LED illuminated in any state. | Check the screen for additional information. | Perform SERVICE A maintenance. Press ENTER to clear. |
| SERVICE B | YELLOW | Yellow LED illuminated in any state. | Check the screen for additional information. | Perform SERVICE B maintenance. Press ENTER to clear. |
| INSPECT BATTERY | YELLOW | Yellow LED illuminated in any state. | Check the screen for additional information. | Inspect battery. Press ENTER to clear. |

Part No. 10000027504 Rev. A 05/18/18

©2018 DR Power Equipment
All rights reserved
Specifications are subject to change without notice.
No reproduction allowed in any form without prior written consent
from DR Power Equipment



75 Meigs Road
Post Office Box 25
Vergennes, Vermont 05491
1-855-447-3734
www.drpower.com