

DR[®] CHIPPER ATTACHMENT

SAFETY & OPERATING INSTRUCTIONS



Serial No. _____

Order No. _____

DR Power Equipment
Toll-free phone: 1-800-DR-OWNER (376-9637)
Fax: 1-802-877-1213
Web site: www.DRpower.com

WARNING

Read and understand this manual and all instructions before operating the DR Chipper Attachment.

Table of Contents

| | |
|--|----|
| Chapter 1: General Safety Rules | 3 |
| Chapter 2: Setting Up Your DR CHIPPER ATTACHMENT | 6 |
| Chapter 3: Operating Your DR CHIPPER ATTACHMENT | 11 |
| Chapter 4: Maintaining The DR CHIPPER ATTACHMENT | 15 |
| Chapter 5: Troubleshooting | 22 |
| Chapter 6: Parts Lists and Schematic Diagrams | 24 |

Conventions used in this manual

! DANGER

This indicates a hazardous situation, which, if not followed, will result in death or serious injury.

! WARNING

This indicates a hazardous situation, which, if not avoided, could result in death or serious injury.

! CAUTION

This indicates a hazardous situation, which, if not avoided, could result in minor or moderate injury.

NOTICE

This information is important in the proper use of your machine. Failure to follow this instruction could result in damage to your machine or property.



Figure 1

Serial Number and Order Number

A Serial Number is used to identify your machine and is located on the Serial Number Label on your machine. An Order Number is used to check and maintain your order history and is located on the upper left portion of your packing slip. For your convenience and ready reference, enter the Serial Number and Order Number in the space provided on the front cover of this manual.

Additional Information and Potential Changes

DR Power Equipment reserves the right to discontinue, change, and improve its products at any time without notice or obligation to the purchaser. The descriptions and specifications contained in this manual were in effect at printing. Equipment described within this manual may be optional. Some illustrations may not be applicable to your machine.

Chapter 1: General Safety Rules

! WARNING

- Read this Safety & Operating Instructions manual before you use the DR CHIPPER ATTACHMENT. Become familiar with the operation and service recommendations to ensure the best performance from your machine.
- Thoroughly inspect the area in which you will be working and remove all foreign objects. Look for rope, wire, etc., and remove these objects before chipping. Inserting these objects into the chipper hopper could damage the machine and/or cause injury.
- This is a high-powered machine, with moving parts operating with high energy at high speeds. You must use proper clothing and safety gear when operating this machine to prevent or minimize the risk of severe injury. This machine can crush, grind, cut, and sever parts of your body if they enter the inlet or discharge area of your chipper.

Labels

Your DR CHIPPER ATTACHMENT carries prominent labels as reminders for its proper and safe use. Shown below are copies of all the safety and information labels that appear on the equipment. Take a moment to study them and make a note of their location on your DR CHIPPER ATTACHMENT as you set up and before you operate the unit. Replace damaged or missing safety and information labels immediately.



#241801

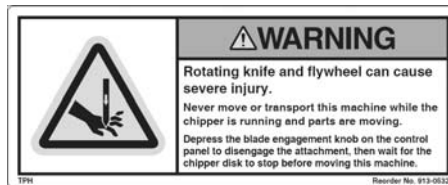

#247981



#247971



#247991



#241991



#247961



#241811



#241821

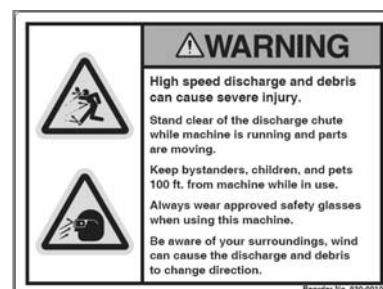

#241831

Protecting Yourself and Those Around You

WARNING

This is a high-powered machine, with moving parts operating with high energy at high speeds. You must operate the machine safely. Unsafe operation can create a number of hazards for you, as well as anyone else in the nearby area. Always take the following precautions when using this machine:

- Always wear protective goggles or safety glasses with side shields while chipping
 - Avoid wearing loose clothing or jewelry, which may catch on moving parts or the material being fed into the chipper hopper.
 - Wear gloves while chipping. Be sure your gloves fit properly and do not have loose cuffs or drawstrings.
 - Wear shoes with non-slip treads. If you have safety shoes, we recommend wearing them. Do not use the machine while barefoot or wearing open sandals.
 - Wear long pants while operating the chipper.
 - Use ear protectors or ear plugs rated for at least 20 dba to protect your hearing.
 - Never allow people who are unfamiliar with these instructions and rules of safe operation to use your machine.
 - Never place your hands, feet, or any part of your body in the chipper hopper, discharge opening, or near or under any moving part while the machine is running. Keep area of discharge clear of people, animals, buildings, glass, or anything else that will obstruct clear discharge, cause injury, or damage. Wind can also change discharge direction, so be aware. If it becomes necessary to push material into the chipper hopper, use a small diameter stick, not your hands.
 - Keep bystanders 100 feet away from your work area at all times. Wood chips exit the chipper at great speeds. To be safe, do not operate the machine near small children or pets, and never allow children to operate the chipper. Stop the chipper when another person or pet approaches.
 - Before performing any maintenance or inspection on the chipper, disengage the blade at the control panel of the Field and Brush Mower. Shut down the engine, wait 5 minutes for engine to cool and all moving parts to come to a complete stop, then remove spark plug wire keeping it away from the spark plug to prevent accidental starting.
 - Never use the machine without ensuring that all guards and shields are in place, including the chipper hopper, discharge chute and blowback shield.
 - Always operate the machine from the operator zone (see “*operation notes*” in Chapter 3). Never pass or stand on the discharge side of the machine when the engine is running or the flywheel is turning.
 - Never try to pick up, move, or transport the machine while the blade is engaged or the flywheel is turning. Disengage the blade at the control panel of the Field and Brush Mower. Shut down the engine, wait for all moving parts to come to a complete stop, then wait 5 minutes before moving.
 - Never, under any conditions, remove, bend, cut, fit, weld, or otherwise alter standard parts on the DR CHIPPER ATTACHMENT. This includes all shields and guards. Modifications to your machine could cause personal injuries and property damage and will void your warranty.
-

WARNING

Tragic accidents can occur if the operator is not alert to the presence of children and pets. Children are often attracted to the machine and the chipping activity. *Never* assume that children will remain where you last saw them. Always follow these precautions:

- Keep children and pets at least 100 feet from the working area and ensure they are under the watchful care of a responsible adult.
 - Be alert and turn the machine off if children or pets enter the work area.
 - Never allow children to operate the DR CHIPPER ATTACHMENT.
-

General Safety

DANGER

Operating this chipper safely is necessary to prevent or minimize the risk of *death or serious injury*. Always take the following precautions when operating this chipper:

- Your DR CHIPPER ATTACHMENT is designed to chip wood. Do not use it for any other purpose.
- Know how to stop the chipper quickly; see “stopping the chipper” in Chapter 3.
- Operate this machine on a level surface only. Never operate your unit on a slippery, wet, muddy, or icy surface. Exercise caution to avoid slipping or falling.
- Keep your face and body back from the chipper hopper to avoid accidental bounce back of any material.
- When feeding material into the chipper hopper be extremely careful that pieces of metal, rocks, or other foreign objects are not included.
- Never allow any processed material to build up in the discharge area as this will prevent proper discharge and may result in kickback from the chipper hopper.
- Always disengage the blade when moving the chipper attachment with the field and brush mower.
- Keep combustible substances away from the engine.
- Never cover the machine while the muffler is still hot.
- If the cutting mechanism strikes a foreign object or if your machine should start making an unusual noise or vibration, disengage the blade at the control panel of the field and brush mower. Shut down the engine, wait for all moving parts to come to a complete stop, remove spark plug wire keeping it away from the spark plug to prevent accidental starting, then wait 5 minutes before inspecting for clogging or damage. Vibration is generally a warning of trouble. Clean and repair and/or replace damaged parts.
- Never tamper with safety devices. Check their proper operation regularly.
- Never overload or attempt to chip material beyond the manufacturer’s recommendation; see Chapter 3.
- Never operate the machine when under the influence of alcohol, drugs, or medication.
- Use the machine only in daylight.
- Keep all nuts and bolts tight and keep the equipment in good operating condition.

WARNING

California Proposition 65:

- This product contains or emits chemicals known to the state of California to cause cancer, birth defects, and other reproductive harm.

Additional Information and Potential Changes

DR Power Equipment reserves the right to discontinue, change, and improve its products at any time without notice or obligation to the purchaser. The descriptions and specifications contained in this manual were in effect at printing. Equipment described within this manual may be optional. Some illustrations may not be applicable to your machine.

No list of warnings and cautions can be all-inclusive. If situations occur that are not covered by this manual, the operator must apply common sense and operate this chipper in a safe manner. Contact us at www.DRpower.com or call 1 (800) dr-owner (376-9637) for assistance.

Chapter 2: Setting Up Your DR CHIPPER ATTACHMENT

This chapter outlines unpacking and a few simple steps you will need to follow to set up your new machine before you use it. It may be helpful to familiarize yourself with the controls and features of your DR CHIPPER ATTACHMENT as shown in *Figure 2* before beginning these procedures.

DR CHIPPER ATTACHMENT Controls and Features

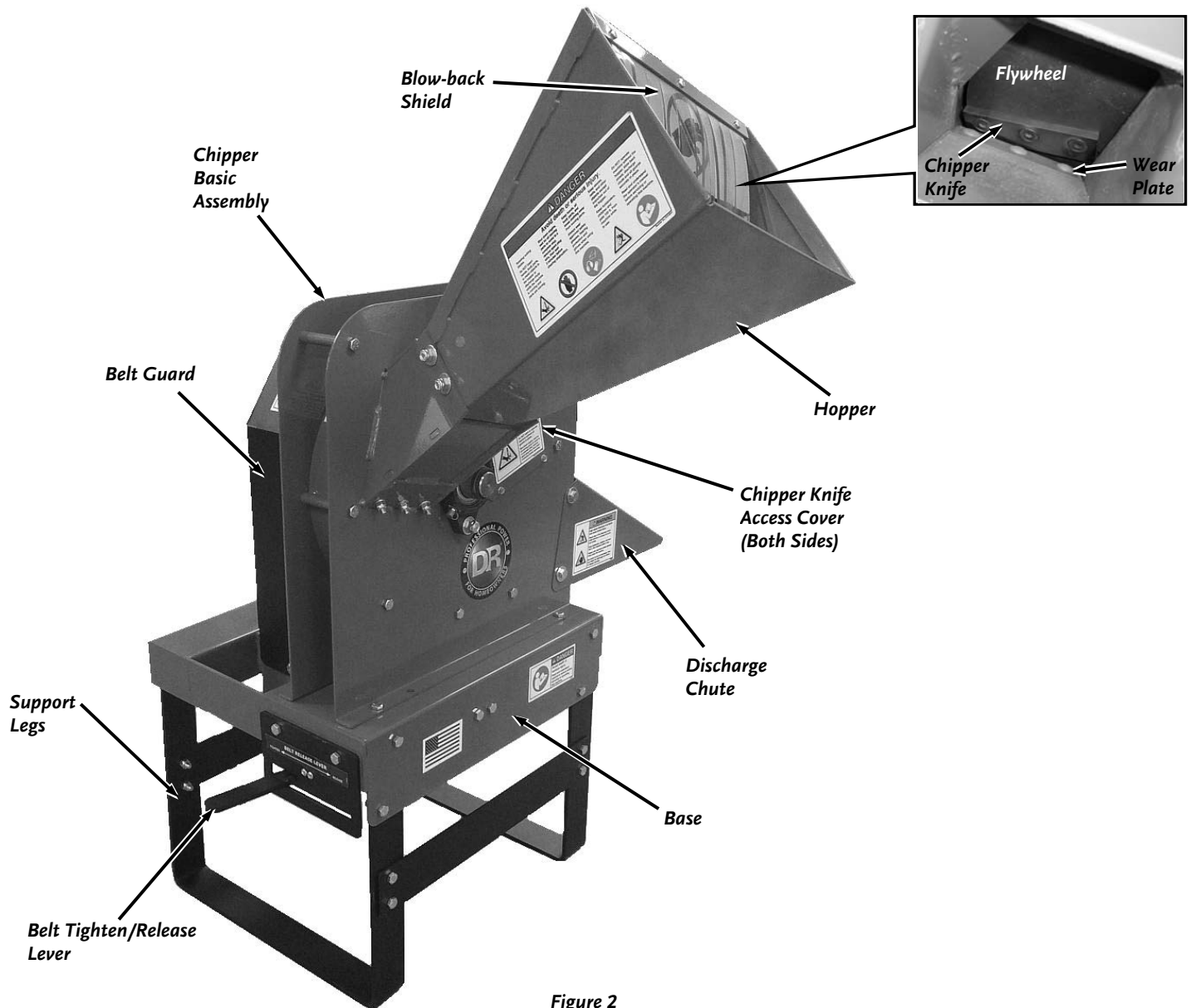

Figure 2

Specifications

MECHANICAL SPECIFICATIONS

| | |
|-----------------------------|--|
| Driven by | DR Field and Brush Mower (V-Belt and Clutch) |
| Chipping Capacity | 3-1/2" Diameter |
| Number of Chipper Knives | 1 |
| Chipper Knife Size | 4-1/8" L x 1-1/4" W, 45 deg |
| Chipper Knife Material | Heat Treated Tool Steel |
| Adjustable Knife Wear Plate | Yes |
| Chipper Flywheel | 12" Diameter, 1/2" Thick |
| Flywheel Weight | 18 lbs |
| Chipper Knife Speed | 95 mph |
| Hopper Material | 14 GA Steel |
| Belt Adjustment | Spring Loaded Idler Pulley W/Manual Engagement |
| Hopper Opening at Top | 8" x 11" |
| Machine Weight | 125 lbs |
| Shipping Dimensions | 24" L x 26" W x 24" H |
| Shipping Weight | 160 lbs |

Parts Supplied:

- Chipper Unit
- Two Legs
- Two Leg Supports
- Parts Box Containing: (items in list below and **Figure 3**)
 - Hopper
 - Discharge Chute
 - Belt
 - Product Package Containing: Owners Manual, Wire Harness and Hardware Package Containing: (items in table below and **Figure 4**)

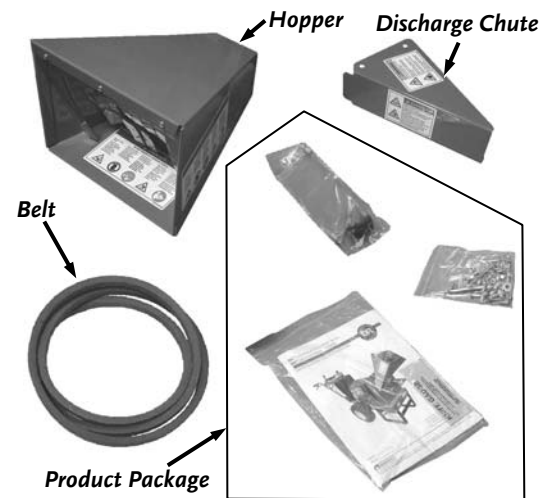

Figure 3

| HARDWARE PACKAGE CONTENTS (FIGURE 3) | | |
|--------------------------------------|-------------------------------|-----|
| ITEM # | DESCRIPTION | QTY |
| 1 | Bolt, 5/16-18 X 4" | 2 |
| 2 | Carriage Bolt, 5/16-18 x 3/4" | 4 |
| 3 | Flat Washer, 5/16 | 9 |
| 4 | Locknut, 5/16-18 | 24 |
| 5 | Screw, 10-24 x 5/8" | 1 |
| 6 | Nut, Nylon Lock, 10-24 | 1 |
| 7 | Bolt, 5/16-18 X 3/4" | 18 |
| 8 | Gap Gauge | 1 |
| 9 | Cable Tie | 7 |
| 10 | OPC Key Lanyard | 1 |
| 11 | OPC Override Switch | 1 |

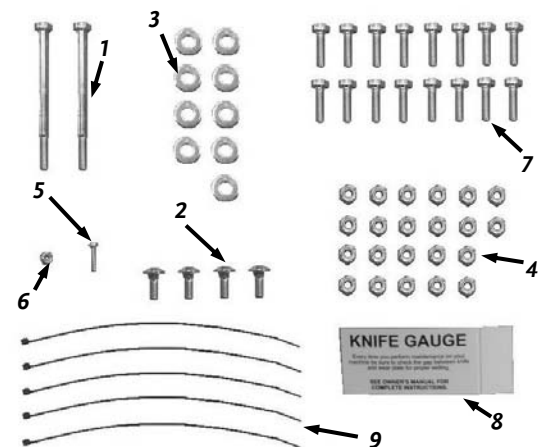

Figure 4

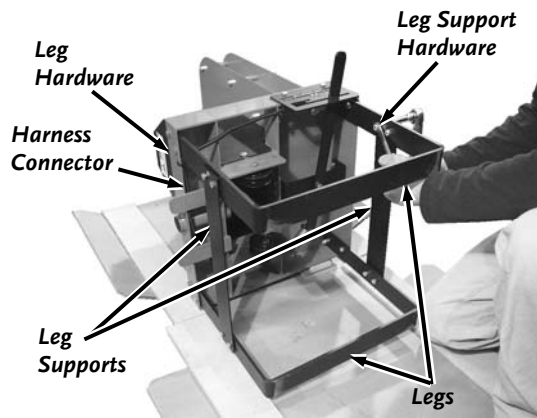

Figure 5

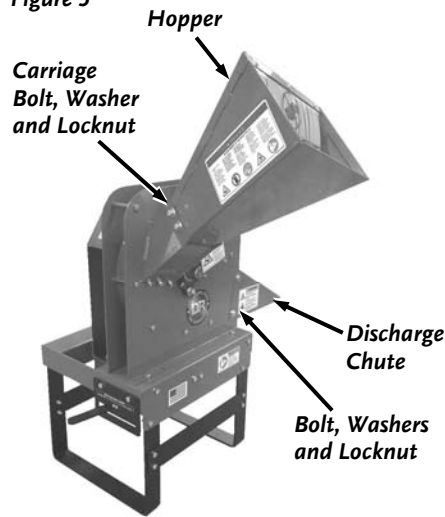

Figure 6

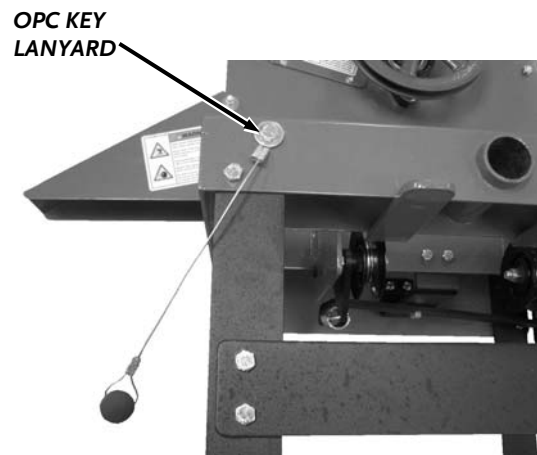

Figure 7

Assembling the Chipper Attachment

Tools Needed:

- Two 1/2" Wrenches
- Soft Faced Hammer

1. Position the Legs onto the Chipper Body and install the Bolts and Locknuts snug but not tight (**Figure 5**).
2. Position the Leg Supports onto the Legs and install Bolts and Locknuts snug but not tight.
3. Tip the machine up onto the Legs, straighten the Legs as needed, then fully tighten the Leg and Leg Support Hardware.

Note: You may need to use a soft faced hammer to carefully tap the Bolts through the holes in the next step.

4. Position the Discharge Chute on the side of the chipper and secure with two Bolts, four Washers (one on each side), and two Locknuts using two 1/2" wrenches (**Figure 6**).

NOTE: Ensure that the square in the Carriage Bolts slide fully into the slots in the Hopper to ensure the bolt heads will rest flush to the Hopper surface.

5. Position the Hopper and secure with four Carriage Bolts (Carriage Bolt Head inside of Hopper and square of Bolt fully into slots in Hopper), four Washers and four Locknuts using a 1/2" wrench.
6. Install the OPC Override Tether using the Leg Hardware and Washer (**Figure 7**).

! WARNING

Before performing this Harness install, stop the engine, wait five (5) minutes to allow all parts to cool. Disconnect the spark plug wires, keeping them away from the spark plugs.

Installing the Chipper Wire Harness onto the DR Field and Brush Mower

1. Remove the Deck or other attachment from the DR Field and Brush Mower (see your DR Field and Brush Mower Safety and Operating Instructions Manual).
2. Tip the DR Field and Brush Mower back onto the handlebars.
3. Disconnect the OPC Wire on the DR Field and Brush Mower and connect the Chipper OPC Wire Harness from the Product Package. (Figure 8 and Figure 9).
4. Snap the Chipper OPC Switch into the DR Field and Brush Mower Frame (Figure 10)
5. Connect the Chipper OPC Wire Harness to the back of the switch.

Mounting the Chipper Attachment to the DR Field and Brush Mower

1. Remove the Hand Knob from the top of the Belt Guard and remove the Guard (Figure 11).
2. Make sure the Retaining Pin and Collar are removed from the Mounting Shaft of the DR Field and Brush Mower.
3. With the help of another person to steady the Chipper as you position the DR Field and Brush Mower; line up the DR Field and Brush Mower Mounting Pin with the Mounting Hole in the Chipper Frame. Push the DR Field and Brush Mower until the Pin is all the way into the Mounting Hole (Figure 11).

CAUTION

Do not pull the Chipper or Brush Mower Attachment away from the DR Field and Brush Mower unless you have someone holding the handlebars to prevent it from falling backward.

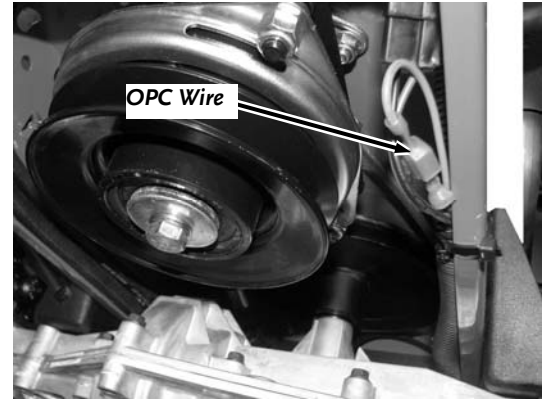

Figure 8

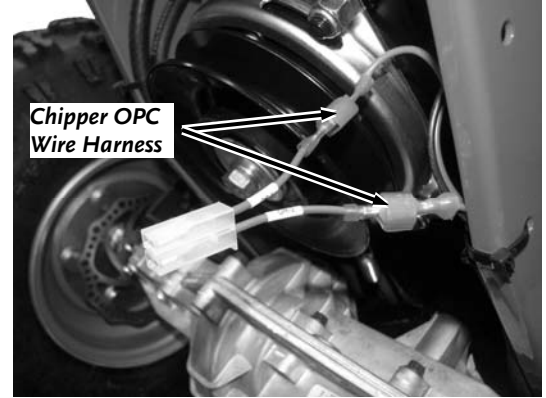

Figure 9

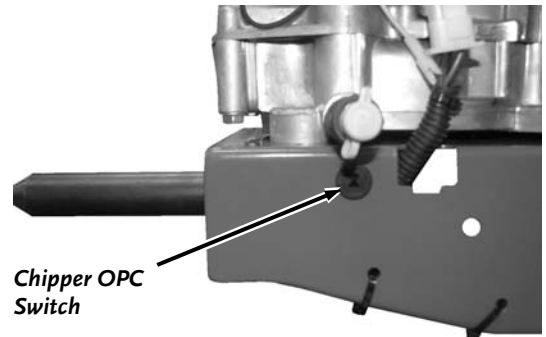

Figure 10

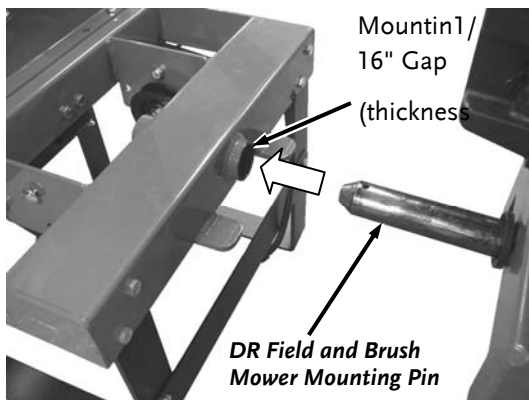

Figure 12

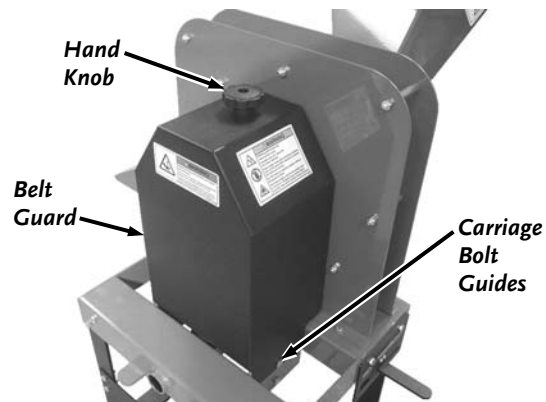

Figure 11

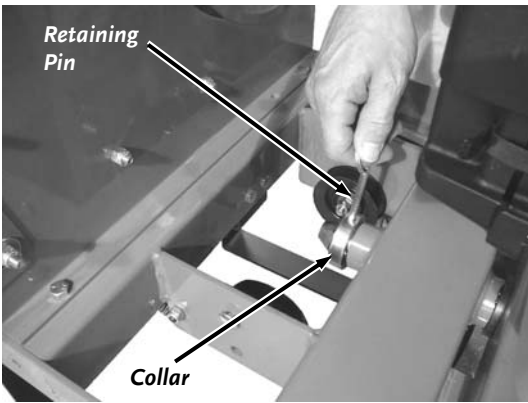

Figure 13

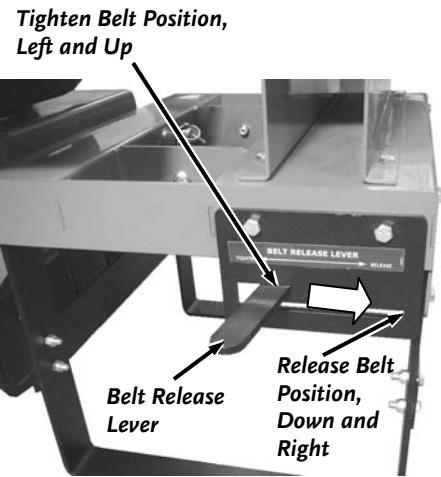

Figure 14

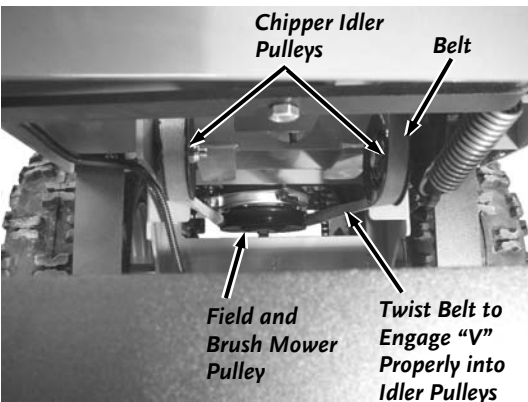

Figure 15

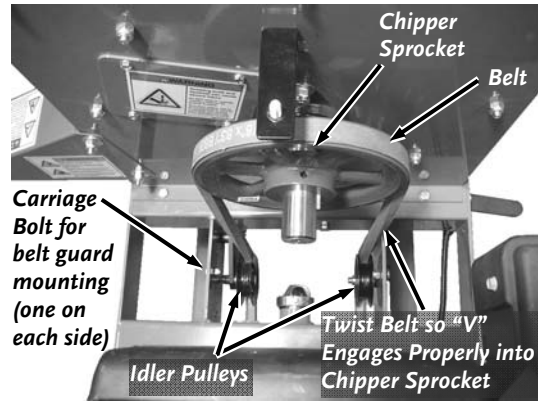

Figure 16

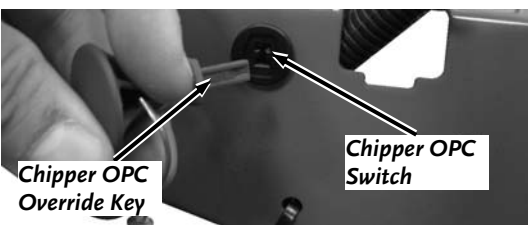

Figure 17

Reinstall the Pin and Collar onto the Mounting Shaft (**Figure 13**).

4. Make sure the Belt Release Lever is in the “Release” position (**Figure 14**).
5. Position the Belt onto the DR Field and Brush Mower Engine Pulley (**Figure 15**) and then route it over the two Idler Pulleys and up around the Chipper Pulley (**Figure 16**).

NOTE: Ensure that the “V” portion of the Belt rests properly into the Idler Pulleys.

6. Move the Belt Release Lever to the “Tighten” position.
7. Reinstall the Belt Guard and secure with the Hand Knob.

NOTE: There are slots at the bottom of the Belt Guard on either side. These slots must slide over the Carriage Bolt Guides that are mounted to the inner Frame Supports of the Chipper (**Figure 11 on previous page**).

8. Plug in the Chipper OPC Override Key from the Chipper Attachment to the Chipper OPC Switch (**Figure 17**).

NOTE: If the OPC Override Key is not inserted the engine will die when the PTO switch is engaged).

Chapter 3: Operating Your DR CHIPPER ATTACHMENT

! DANGER

- This machine was designed for chipping wood. Never use this machine for any other purpose as it could cause serious injury.
- Contact with internal rotating parts will cause serious personal injury. Never put hands, face, feet, or clothing into chipper hopper or discharge opening or near the discharge area at any time.
- Before performing any maintenance procedure or inspection, disengage the blade at the control panel of the DR Field and Brush Mower. Shut down the engine, wait for all moving parts to come to a complete stop, remove spark plug wire keeping it away from the spark plug to prevent accidental starting, then wait 5 minutes before proceeding. Use only a wooden stick to clear jammed material.

Operating the Chipper Attachment

It may be helpful to familiarize yourself with the features on your Machine by reviewing **Figure 2** in Chapter 2 before beginning the steps outlined in this chapter. The instructions in your DR Field and Brush Mower Safety and Operating Instructions Manual indicate that the engine will shut off if you release the Operator Presence Lever. Although this is true with some attachments, it does not apply to the Chipper Attachment when installed properly. The Operator Presence override feature of the Chipper Harness that you installed in Chapter 2 will enable you to operate the Chipper even though the Operator Presence Lever is not held down as long as the Key Switch is in the “Run” position. When the Chipper OPC override key is disconnected from the Field and Brush Mower, the Operator Presence lever will function normally for other attachments.

Starting the Chipper

NOTE: Remove any debris buildup from the machine before every use of the Chipper.

1. Ensure that the Belt Release Lever on the Chipper Attachment is in the “Tighten” position.
2. Plug the OPC Override Key into the switch on the side of the Frame (**Figure 17**)
3. Position the machine on a level surface and set the Parking Brake on your DR Field and Brush Mower.
4. Make certain that the Shift Lever is in the Neutral position and the PTO Control Knob is pushed down to the “Disengaged” position (**Figure 18**).
5. Start the engine in accordance with the Safety & Operating Instructions for your DR Field and Brush Mower
6. After the engine has warmed up, start the Chipper by pulling up on the PTO Control Knob to the “Engaged” position (**Figure 18**).
7. Once the Chipper has engaged increase the Throttle to Fast .

NOTE:

- Always operate the Field and Brush Mower at maximum RPM when chipping.
- If the OPC Override Key is not plugged in, Pulling up on the PTO Control Knob will stop the engine.

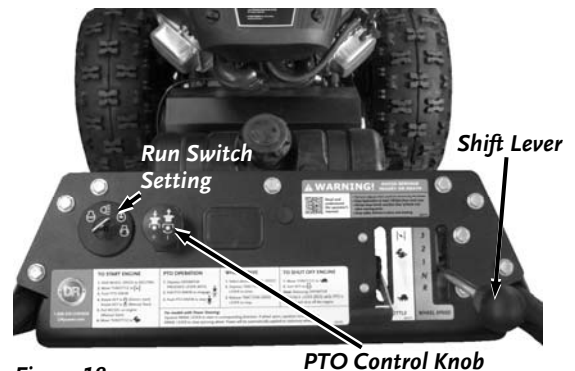

Figure 18

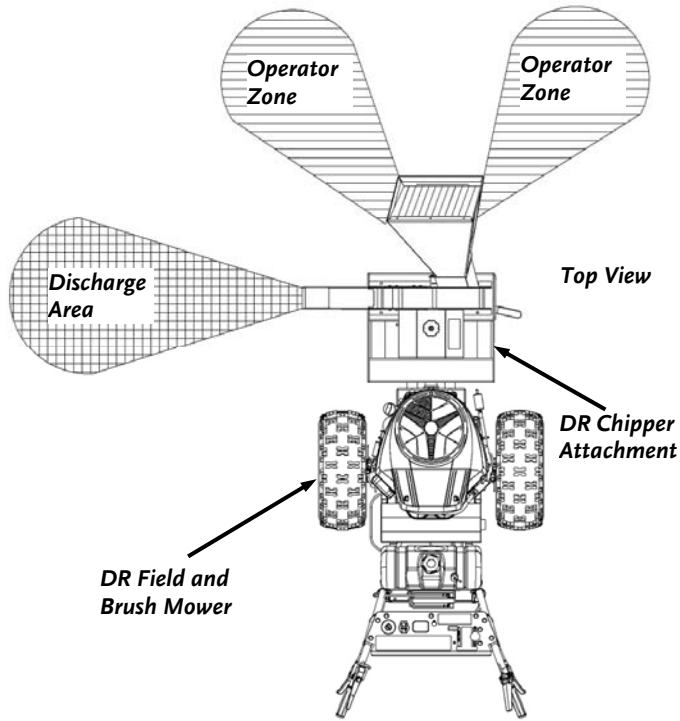

Figure 19

Stopping the Chipper

1. Push in the PTO Knob on the Control Panel, return the Throttle to Idle and turn off the Field and Brush Mower engine. Be sure to remove the Key from the DR Field and Brush Mower for safety.

NOTE: When removing the DR CHIPPER ATTACHMENT from the DR Field and Brush Mower, be sure to disconnect the OPC Override Key.

Operation Notes

- Visually check the Chipper Knife for damage before each use of the machine. See “Visual Inspection of the Chipper Knife (before each use)” in Chapter 4 for info on accessing the Chipper Knife (remove the Front Knife Access Cover only).
- Always operate the Engine at full speed when chipping.
- Only operate the DR CHIPPER ATTACHMENT from the Operator Zone (**Figure 19**).
- Keep proper balance and footing while operating the DR CHIPPER ATTACHMENT.
- ALWAYS push in the PTO Knob to disengage the Chipper and stop the engine when leaving the Operating Zone or when moving the machine.
- Never move the Machine while the Flywheel is turning.

Processing Material

! WARNING

- Always wear protective goggles or safety glasses with side shields while chipping to protect your eyes from possible thrown debris.
- Avoid wearing loose clothing or jewelry, which might catch on moving parts or the material fed into the chipper hopper.
- We recommend wearing gloves while chipping. Be sure your gloves fit properly and do not have loose cuffs or drawstrings.
- Wear shoes with non-slip treads when using your chipper. If you have safety shoes, we recommend wearing them. Do not use the machine while barefoot or wearing open sandals.
- Wear long pants while operating the DR CHIPPER ATTACHMENT.
- Use ear protectors or ear plugs rated for at least 20 dba to protect your hearing.
- The chipper hopper must be securely bolted to your DR CHIPPER ATTACHMENT and the blowback shield in place before using the machine.

NOTICE

Use common sense when using the machine. Learn to recognize the change in sounds when overloaded. Disengage the blade at the control panel of the DR Field and Brush Mower immediately if the machine becomes jammed to prevent damage to the drive system.

The Chipper is designed to accept wood only. The Chipper Knife mounted on a revolving flywheel turns branches fed into the Chipper Hopper into “chips”. The Chipper can chip branches ranging in size up to 3-1/2" in diameter. Cut your branches into manageable lengths before feeding them into the Chipper Hopper.

- Your DR CHIPPER ATTACHMENT can process dry or green wood up to 3.5" in diameter.
- Green wood will process quicker and easier than dry wood.
- Softwood processes easier than hardwood.
- Your operator experience will teach you how different types of wood will chip and how fast you can process them.
- When chipping branches, sometimes a tail will develop at the end of a branch. To avoid this, rotate the branch while feeding it into the Chipper Hopper.
- Rotating the branch as you feed it into the machine will improve chipping performance.
- Use caution with small diameter green saplings and branches less than 2" in diameter. Chip these grouped or bundled together to provide support for each other. If the material is 2" or larger, feed only one at a time into the Chipper Hopper.
- Make sure the DR CHIPPER ATTACHMENT finishes processing material in the Hopper before pushing down the PTO Control Knob and shutting the engine off.
- Do not force material into the Chipper. If the machine does not chip well, the Chipper Knife may need sharpening or replacement, or the gap between the Knife and the Wear Plate needs adjusting. See “Removing, Replacing and Adjusting the Chipper Knife and Wear Plate” in Chapter 4.
- Extremely hard knots will not process very well. Use the next branch to be chipped to push any short stubs that have not self-fed through the Chipper.
- Cut the material to be chipped into manageable lengths of no more than five or six feet long before chipping them.
- Overloading the Chipper Hopper will cause the rotor speed to decrease. If you hear the engine RPM of the DR Field and Brush Mower decreasing, stop feeding material into the Chipper Hopper until the engine has returned to full speed.

NOTICE

Never throw remaining stubs or knots into the chipper hopper; damage will result.

To Free a Jammed Flywheel

WARNING

Push in the PTO Knob at the control panel of the field and brush mower. Shut down the engine, wait for all moving parts to come to a complete stop, remove spark plug wire(s) keeping it away from the spark plug(s) to prevent accidental starting, then wait 5 minutes before performing maintenance procedures or inspection on the chipper.

Tools Needed:

- Two 1/2" Wrenches

Disassemble:

1. Remove any material left in the Chipper Hopper.

NOTICE

Never pry against the scroll weldment when removing the deflector or at any other time. This will cause damage to the machine.

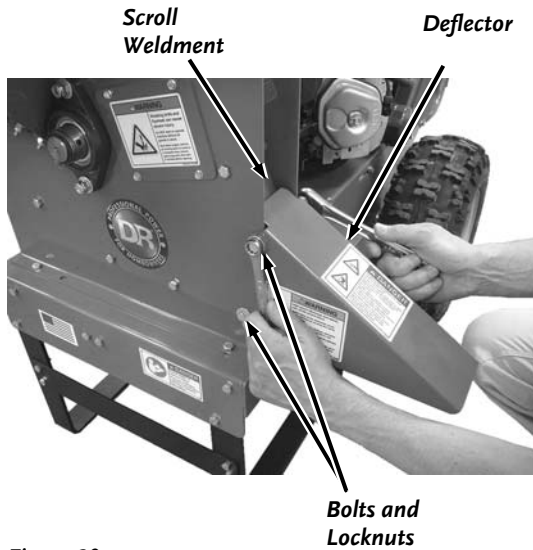

Figure 20

2. Remove the two Bolts, four Washers and two Locknuts that secure the Deflector to the Chipper Assembly with two 1/2" wrenches and then remove the Deflector (**Figure 20**).
3. Check to see if the Deflector opening is clogged. If it is, clear it with a branch.

NOTE: You may need to remove the Belt from the Chipper Pulley so the Flywheel is allowed to turn freely for the next step.

4. With a wooden stick, loosen and remove any material left in the Chipping Chamber and make sure the Flywheel turns freely with the stick.

! WARNING

Always Reassemble Deflector before using machine

Reassemble:

1. Position the Deflector onto the Chipper Assembly and secure with two Bolts, four Washers (one on each side) and two Locknuts using two 1/2" wrenches (**Figure 20**).
2. Reconnect the spark plug wire, start the DR Field and Brush Mower engine, engage the PTO Knob; allowing the remaining material in the Chipping Chamber to discharge.
3. If the Chipping Chamber doesn't clear and the flywheel is still jammed, repeat above process.

NOTE: Be certain the Chipping Chamber is clear before trying to process more material into the Chipper Hopper.

Chapter 4: Maintaining The DR CHIPPER ATTACHMENT

For DR Field and Brush Mower maintenance, please refer to the Safety and Operating Instructions Manual that came with your DR Field and Brush Mower.

Regular Maintenance Check List

NOTE: Consider that the service intervals shown are the maximum under normal operating conditions. Increase frequencies under extremely dirty or dusty conditions.

! WARNING

Push in the PTO Knob at the control panel of the DR Field and Brush Mower. Shut down the engine, wait for all moving parts to come to a complete stop, remove spark plug wire keeping it away from the spark plug to prevent accidental starting, then wait 5 minutes before performing maintenance procedures or inspection on the chipper.

| Procedure | Before Each Use | Every 8-10 Hours | Every 40 Hours |
|---|-----------------|------------------|----------------|
| Check General Equipment Condition | ▲ | | |
| Check that the Flywheel turns freely (with a long stick only) | ▲ | | |
| Visually inspect Knife for damage | ▲ | | |
| Check Knife and Wear Plate for Sharpness | | ▲ | |
| Check Knife and Wear Plate Attachment Screws | | ▲ | |
| Check Flywheel Bearing Collar Set Screws | | ▲ | |
| Check Knife to Wear Plate Gap | | ▲ | |
| Lubricate Flywheel Bearings | | ▲ | |
| Check Belt Condition | | ▲ | |
| Replace Drive Belt | | | ▲ |

Grease Fittings

Your DR CHIPPER ATTACHMENT was greased at the Factory. The operator needs to periodically lubricate the two Bearings of the Chipper Assembly.

! WARNING

Press in the PTO Knob at the control panel of the DR Field and Brush Mower. Shut down the engine, wait for all moving parts to come to a complete stop, remove spark plug wire(s) keeping it away from the spark plug(s) to prevent accidental starting, then wait 5 minutes before performing maintenance procedures or inspection on the chipper.

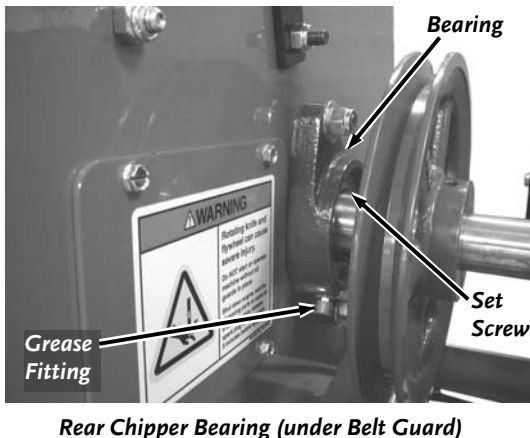
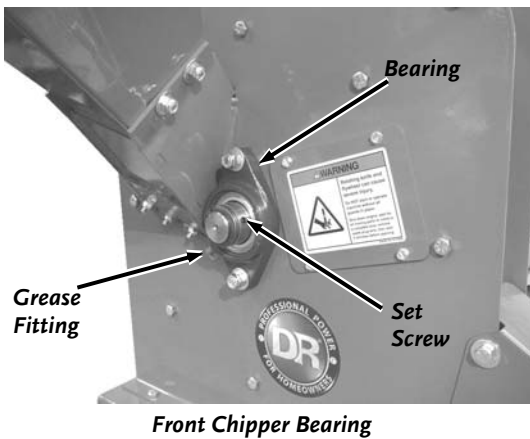

Figure 21

Tools and Supplies needed:

- Flexible hose grease gun
- Lithium grease
- Clean cloth
- 5/32" Allen Wrench
- Thread Lock (if needed)

1. Unscrew the Hand Knob and remove the Belt Guard.
2. Wipe all dirt, etc., from the grease fittings with a clean cloth (**Figure 21**).
3. Apply no more than three pumps of quality general-purpose lithium grease with a hand-pumped grease gun to each Bearing Grease Fitting, one on either side of the Chipper Assembly.

NOTICE

Over lubrication can damage the bearings

4. Check the Set Screws for tightness. If they are not tight they should be removed, apply Thread Lock to the threads, then reinstall and tighten the Set Screws.
5. Position the Belt Guard and secure with the Hand Knob.

Removing, Replacing and Adjusting the Chipper Knife and Wear Plate

INSPECTING THE CHIPPER KNIFE AND WEAR PLATE

Routine inspection of the Chipper Knife and Wear Plate will ensure that your DR CHIPPER ATTACHMENT is operating at full efficiency (see “Regular Maintenance Checklist” at the beginning of this Chapter). Operating with a worn or damaged Chipper Knife or Wear Plate will cause extreme stress and vibration to the machine and make chipping difficult for the operator.

The Knife should be visually checked for damage before each use. The first procedure (“Routine Visual inspection of the Chipper Knife”) describes a quick way to check the Knife only through the Access Cover. The second procedure (“Visual inspection of the Chipper Knife and Wear Plate”) is for a more detailed look at the condition of the Knife and Wear Plate by removing the Hopper.

NOTICE

- Routinely check the chipper knife for sharpness. Using a dull knife will decrease performance and cause excessive vibration that may cause damage to the DR CHIPPER ATTACHMENT.
- Routinely check the wear plate for a sharp square edge. Using a rounded or chipped wear plate will decrease performance and cause excessive vibration that will cause damage to the DR CHIPPER ATTACHMENT.

WARNING

Press in the PTO Knob at the control panel of the DRField and Brush Mower. Shut down the engine, wait for all moving parts to come to a complete stop, remove spark plug wire keeping it away from the spark plug to prevent accidental starting, then wait 5 minutes before performing maintenance procedures or inspection on the chipper.

VISUAL INSPECTION OF THE CHIPPER KNIFE (before each use)

Tools Needed:

- 5/16" Wrench
1. Remove the four Screws that secure the Front Access Cover with a 5/16" wrench and remove the Access Cover (**Figure 22**).

NOTE: You may need to remove the Belt from the Chipper Pulley so the Flywheel is allowed to turn freely for the next step.

2. Rotate the Flywheel with a long stick until the Knife is visible.
3. If the Knife has visible nicks or damage it must be sharpened or replaced (see "Removing and Replacing the Chipper Knife" in this chapter).
4. If the Knife does not appear to have any damage, replace the Access Cover and secure with four Screws using a 5/16" wrench.

VISUAL INSPECTION OF THE CHIPPER KNIFE AND WEAR PLATE (every 8-10 hours)

Tools Needed:

- 1/2" Wrench
1. Use a 1/2" wrench to remove the four Carriage Bolts, Washers and Locknuts that support the Hopper to the Chipper Assembly (**Figure 23**).
 2. Remove the Hopper from the Chipper Assembly.

NOTE: You may need to remove the Belt from the Chipper Pulley so the Flywheel is allowed to turn freely for the next step.

3. Use a long stick to rotate the Flywheel until the Knife is next to the Wear Plate.
4. Closely inspect the Chipper Knife and Wear Plate for nicks or dull (rounded) edges (**Figure 24**).
5. If necessary, sharpen or replace the Chipper Knife and/or Wear Plate per the following procedures.
6. Replace the Hopper when finished.

Removing and Replacing the Chipper Knife

Tools and Supplies Needed:

- 5/16" Wrench
- 3/16" Allen wrench
- 1/2" Socket
- Awl or Sharp Tool
- Gloves

⚠ WARNING

Be careful and wear gloves when working near the chipper knife. The knife edge can cut you if you come in contact with it.

1. Remove the Hand Knob and then remove the Belt Guard.
2. Using a 5/16" Wrench, remove the Self-Tapping Screws and remove both Knife Access Covers from the front and back of the Chipper Assembly (**Figure 25**).

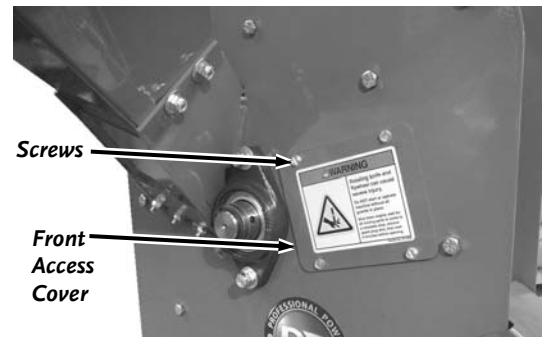

Figure 22

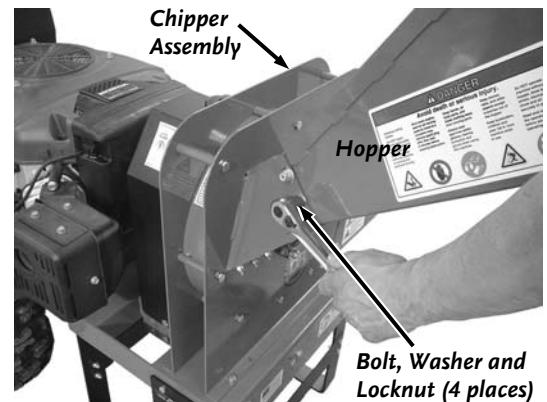

Figure 23

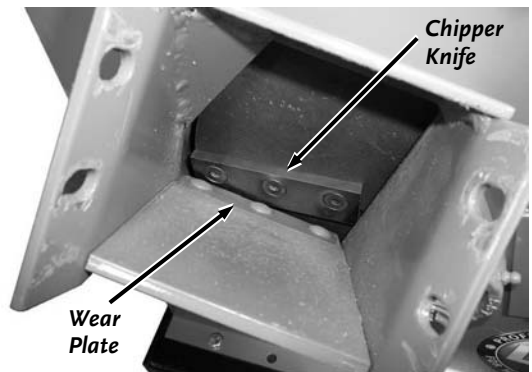

Figure 24



Figure 25

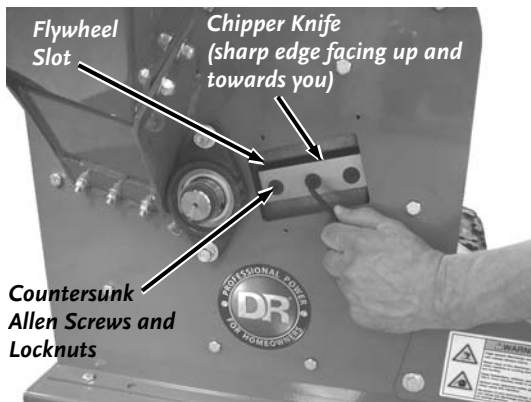

Figure 26

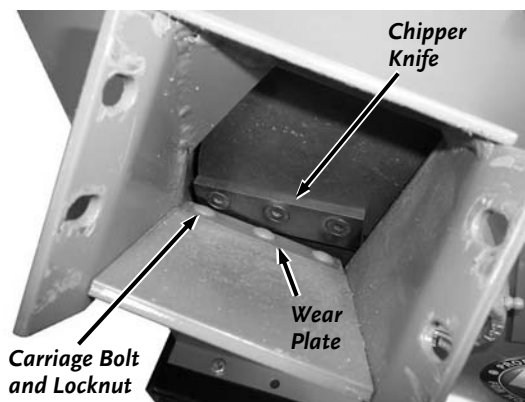

Figure 27

NOTE: You may need to remove the Belt from the Chipper Pulley so the Flywheel is allowed to turn freely for the next step.

3. Rotate the Flywheel using a long stick until the three countersunk Allen Screws and Locknuts attaching the Knife to the Flywheel are visible through the Access Openings (**Figure 25**).
4. Clean out the heads of the Allen Screws with an Awl or Sharp Tool.
5. Insert a 3/16" Allen Wrench into the head of a screw.
6. While holding the Allen Wrench, remove the Locknut using a 1/2" socket.
7. Repeat Steps 5 and 6 for the remaining two Allen Screws.
8. Remove the dull or damaged Knife and visually inspect the Flywheel Slot and Knife mounting area and be sure they are clean and that the replacement Knife will be able to mount flush against the Flywheel.
9. Install a new or sharpened Knife as shown (**Figure 26**) with the Knife edge facing up and towards you and finger tighten the Allen screws and Locknuts (use the new hardware supplied with a new Knife kit) to hold the Knife to the Flywheel.
10. Using a 3/16" Allen wrench and a 1/2" socket, tighten the center Screw and Locknut, tighten the outer Screw and Locknut, then tighten the inner Screw and Locknut.

CAUTION

If the flywheel surface is not cleaned properly and the chipper knife is not mounted flush on the flywheel, the knife could crack when the hardware is tightened.

11. Double-check that all three Locknuts on the Allen Screws are tight.
12. Reinstall the two Access Covers.
13. Replace the Belt Guard.
14. Check and if needed adjust the gap between the Knife and Wear Plate (See "Checking and Adjusting the Knife to Wear Plate Gap" in this Chapter).

Removing and Replacing the Wear Plate

Tools Needed:

- 7/16" wrench

1. Remove the Hopper (See "Inspecting the Chipper Knife and Wear Plate" in this Chapter).
2. Use a 7/16" wrench to remove the three Locknuts and Carriage Bolts that attach the Wear Plate to the Chipper Assembly and then remove the Wear Plate (**Figure 27**).
3. Install the new Wear Plate and secure with the Carriage Bolts and Locknuts.

NOTE: The Gap between the Knife and Wear Plate must be adjusted whenever the Wear Plate is removed. See the following instructions.

Checking and Adjusting the Knife to Wear Plate Gap

When you replace the Knife or Wear Plate, you must check and set the clearance between the Knife and Wear Plate. Set this clearance or gap to 1/16" by using the Gap Tool that is supplied with the Chipper and with a new Knife Kit. If the gap between the

WARNING

Disengage the blade at the control panel of the DR Field and Brush Mower. Shut down the engine, wait for all moving parts to come to a complete stop, remove spark plug wire keeping it away from the spark plug to prevent accidental starting, then wait 5 minutes before performing maintenance procedures or inspection on the chipper.

If the Wear Plate and the Knife is not set correctly, you will have excessive vibration when chipping and the Knife will seem to be dull. The Wear Plate should have a square edge and be free of dents or gouges. The Wear Plate can be hand sharpened (see steps below). Be careful not to overheat it during the sharpening process. This will change the characteristics of the steel and you will then have to replace the Wear Plate (see "Wear Plate Sharpening" in this chapter).

Checking the Knife to Wear Plate Gap

Tools Needed:

- Gap Gauge (provided with Chipper)

1. Remove the Hopper (See "Inspecting the Chipper Knife and Wear Plate" in this Chapter).

NOTE: You may need to remove the Belt from the Chipper Pulley so the Flywheel is allowed to turn freely for the next step.

2. Use a stick to rotate the Flywheel until the Knife is positioned next to the Wear Plate.
3. Slide the Knife Gap Gauge in between the Knife and Wear Plate to check the clearance (**Figure 28**).
 - If the Knife Gauge slides freely, with no resistance and a lot of extra space, the Wear plate must be adjusted.
 - If the Knife Gauge will not slide down between the Knife and Wear Plate, the Wear Plate must be adjusted.
 - If the Knife Gauge slides in between the Knife and Wear Plate with some resistance felt against them both or slides in between with no noticeable space, then the Wear plate is properly adjusted.
4. Install the Hopper when finished.

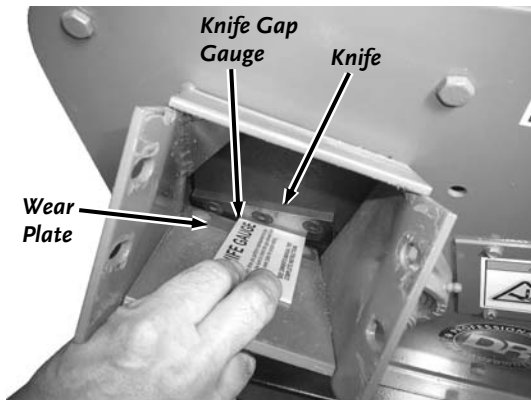

Figure 28

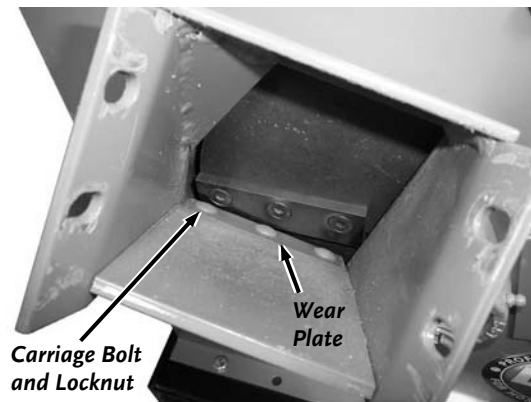

Figure 29

Adjusting the Knife to Wear Plate Gap

Tools Needed:

- 7/16" wrench
- Gap Gauge (provided with Chipper)

1. To adjust the Wear Plate Gap, loosen the three Nuts on the Carriage Bolts with a 7/16" wrench just enough so the Wear Plate will move but still have a slight resistance. Now you can slide the Wear Plate up or down (in or out) to achieve the correct gap setting (**Figure 29 and 30**).
2. Take the Gap Gauge and slide it between the Knife and Wear Plate (**Figure 28**). Adjust the Wear Plate against the Knife Gauge and tighten the outside

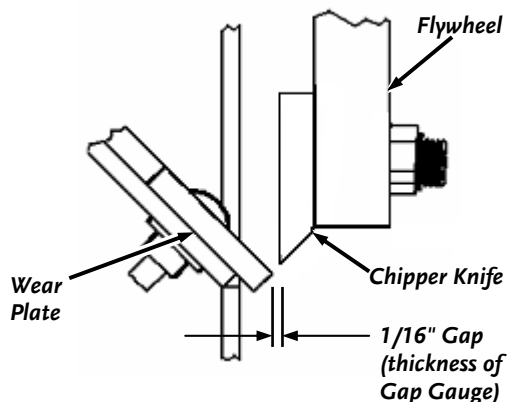

Figure 30

Locknut, check the gap, tighten the inside Locknut and then the center Locknut.

3. Check the adjustment as described in the “Checking the Knife to Wear Plate Gap” in the previous section.
4. Reinstall the Hopper when finished.

Chipper Knife Sharpening

NOTICE

After any knife or wear plate maintenance or adjustment, rotate the chipper flywheel by using a wooden stick and watch and listen carefully for any unusual noises, clicking or vibration. If you detect any of these, inspect the machine for damage, or any loose parts. Repair or replace any damaged parts and tighten any loose parts before starting the DR CHIPPER ATTACHMENT.

- You should never attempt to sharpen the Chipper Knife freehand.
- It is extremely important to consistently maintain the 45-degree angle for proper performance (**Figure 31**).
- Excessive heat generated during the sharpening process will damage Knives and weaken the metal. Be sure not to overheat the Knife during sharpening because it will shorten the life of the Knife.
- Take the Chipper Knife to a machine shop for proper sharpening.
- How many times a Knife can be sharpened is determined by how much material needs to be taken off to sharpen or to compensate for dents or gouges.
- A new Chipper Knife has 5/16" measurement between the short side bevel edge and the Knife mounting holes (**Figure 32 “New Knife”**).
- The knife should never be sharpened to the extent that more than 3/32" is

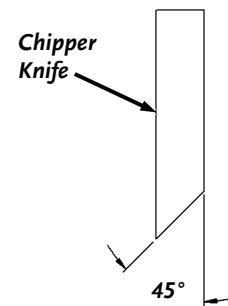

Figure 31

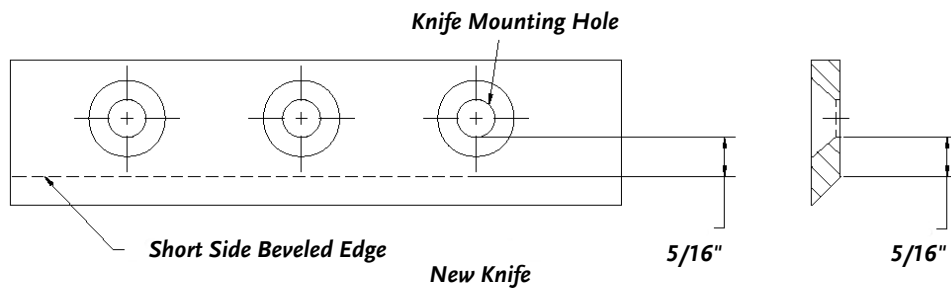

Figure 32

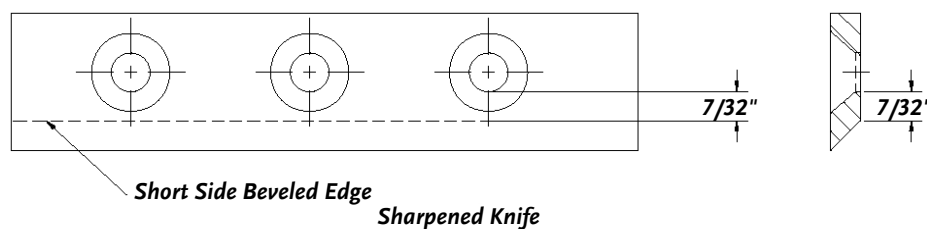

Figure 33

taken off this measurement.

- Once this measurement is below 7/32" (see **Figure 33 “Sharpened Knife”**), or if you are unable to remove dents or gouges with these guidelines, replace the Knife.

Wear Plate Sharpening

The Wear Plate edges become rounded and chipped during use and must be squared off to ensure efficient operation.

Tools Needed:

- Flat File
- Straightedge

1. Secure the Wear Plate in a vise.
2. File the edge of the Wear Plate to take out any nicks and to square rounded edges (**Figure 34**).
3. Check with a Straightedge to ensure that the Wear Plate edge is flat and straight.

NOTE: If the Wear Plate is filed enough times that the proper gap between the Knife and Wear Plate can not be set with the Gap Gauge, you will need to replace the Wear Plate.

Replacing the Belt

1. Remove the Hand Knob from the top of the Belt Guard and remove the Guard (**Figure 34**).
2. Make sure the Belt Release Lever is in the “Release” position (**Figure 36**).
3. Rotate the Chipper Pulley as you slid the belt from it.
4. Remove the Belt from the DR Field and Brush Mower Pulley.
5. Position the Belt onto the Field and Brush Mower Pulley (**Figure 36**) and then route it over the two Idler Pulleys and up around the Chipper Pulley (**Figure 38**).

NOTE: Ensure that the “V” portion of the Belt rests properly into the Idler Pulleys.

6. Move the Belt Release Lever to the “Tighten” position.

NOTE: There is a slot in each of the bottom Tabs of the Belt Guard. These slots must slide over the Carriage Bolt Guides that are mounted to the inner Frame Supports of the Chipper (**Figure 35**).

7. Reinstall the Belt Guard and secure with the Hand Knob.

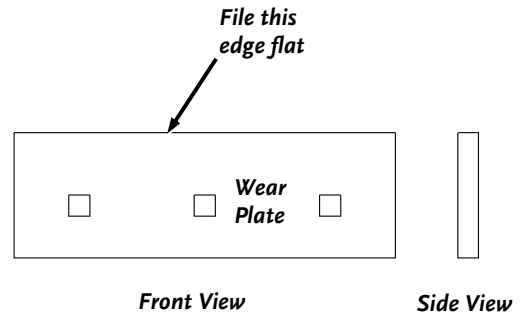

Figure 34

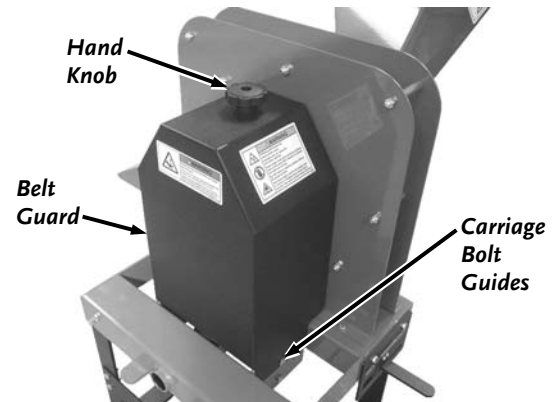

Figure 35

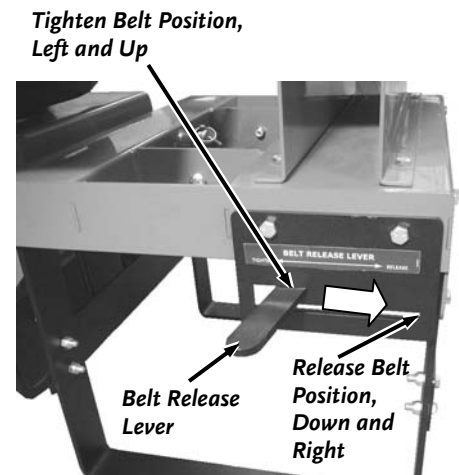

Figure 36

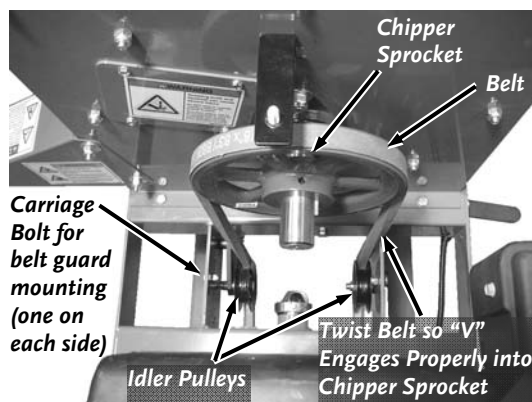

Figure 38

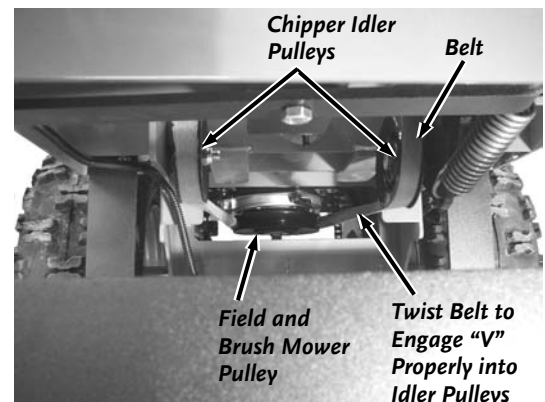

Figure 37

Chapter 5: Troubleshooting

WARNING

Press in the PTO Knob at the control panel of the Field and Brush Mower. Shut down the engine, wait for all moving parts to come to a complete stop, remove spark plug wire keeping it away from the spark plug to prevent accidental starting, then wait 5 minutes before performing maintenance procedures or inspection on the chipper.

Most problems are easy to fix. Consult the Troubleshooting Table below for common problems and their solutions. If you continue to experience problems, **contact us at www.DRpower.com or call 1-800-DR-OWNER (376-9637)** for support.

Troubleshooting Table

| SYMPTOM | POSSIBLE CAUSE |
|---|---|
| <i>Chipping action seems too slow or flywheel stalls.</i> | <ul style="list-style-type: none"> ⇒ The engine speed is too slow causing the belt to slip. Run the engine at full throttle. ⇒ Check for a loose or damaged Drive Belt; tighten or replace. See Chapter 4. ⇒ Check for a dull or damaged Knife; sharpen or replace the Knife. See Chapter 4. |
| <i>The belt frays or rolls over the pulley.</i> | <ul style="list-style-type: none"> ⇒ The rotor Drive Pulley groove may be nicked. Check the Drive Belt for wear and hard spots. File off any nicks on the pulley. ⇒ The Drive Belt may be stretched; replace it. See Chapter 4. |
| <ul style="list-style-type: none"> - Belt burns. - Flywheel won't turn. | <ul style="list-style-type: none"> ⇒ Immediately disengage the PTO Knob, stop the engine and disconnect the spark plug wire. ⇒ Turn the Flywheel with a wooden stick to be sure it turns freely. ⇒ Check for a loose Drive Belt. See Chapter 4. ⇒ Remove any built up debris from the Chipper Hopper Inlet and Discharge Chute. |
| <i>The machine has excessive vibration.</i> | <ul style="list-style-type: none"> ⇒ Check for a dull or damaged Knife; sharpen or replace the Knife. See Chapter 4. ⇒ The Knife is not properly seated on the flywheel. Loosen the Knife mounting screws, reset the Knife and tighten the screws. Also, check the Knife to Wear Plate Gap. See Chapter 4. ⇒ If the machine still exhibits excessive vibration, contact us at www.DRpower.com or call 1 (800) DR-OWNER (376-9637) for assistance. |
| <i>When chipping, the log seems to vibrate excessively and "hammers" my hands.</i> | <ul style="list-style-type: none"> ⇒ The Knife is dull; sharpen or replace it. See Chapter 4. ⇒ The gap between the Knife and Wear Plate is too great; adjust the Gap. See Chapter 4. ⇒ Check Engine rpms; run Engine at full throttle when chipping. |
| <i>Chipper Knife is hitting the Wear Plate.</i> | <ul style="list-style-type: none"> ⇒ The gap between the Knife and the Wear Plate is set incorrectly; adjust the Knife to Wear Plate Gap. See Chapter 4. ⇒ If adjusting the gap did not fix the problem, contact us at www.DRpower.com or call 1 (800) DR-OWNER (376-9637) for assistance. |
| <i>Engine will not run unless Operator Presence lever is held down.</i> | <ul style="list-style-type: none"> ⇒ Is the Chipper OPC Override key plugged into the Chipper OPC Switch? Plug the key into the switch. ⇒ If the Engine still will not run unless the Operator Presence is held down please contact us at www.DRpower.com or call toll-free at 1 (800) DR-OWNER (376-9637) for assistance. |

Chapter 6: Parts Lists and Schematic Diagrams

Parts List – FRAME ASSEMBLY

NOTE: Part numbers listed are available through DR Power Equipment.

| <u>Ref#</u> | <u>Part#</u> | <u>Description</u> | <u>Ref#</u> | <u>Part#</u> | <u>Description</u> |
|-------------|--------------|--|-------------------------------|--------------|---|
| 01 | 241821 | Label, Warning Rotating Parts, 4.5" X 3" | 26 | 247811 | Grip, Handle |
| 02 | 143661 | Knob, 5/16-18 | 27 | 264401 | Leg, Base, ATM Chip |
| 03 | 247981 | Label, Do Not Move | 28 | 263941 | Guard Assembly, ATM Chipper, Belt w/ Labels |
| 04 | 110761 | Nut, Nylon Lock, 5/16-18 | 29 | 256151 | Support, Leg |
| 05 | 366301 | Belt, BK73, 5/8 X 75.8" | 30 | 123211 | Bolt, HCS, 5/16-18 X 3/4", GR5, ZP |
| 06 | 247761 | Pulley, V, 7.5" OD | 31 | 247961 | Label, Danger, Death/Injury 7.75"X4" |
| 07 | 142291 | Key, Square, 1/4 X 1-1/4 | 32 | 124371 | Label, American Flag, 2.75" X 1.75" |
| 08 | 112411 | Washer, Flat, 5/16", USS | 33 | 263931 | Chipper Basic Weldment w/ Labels |
| 09 | 145291 | Bolt, Carr, 5/16-18 X 3/4" | 34 | 256131 | Bracket, Belt Guard |
| 10 | 263891 | Deflector w/ Labels | 35 | 247991 | Label, Belt Release |
| 11 | 241811 | Label, Danger, Discharge Chute 4" X 3" | 36 | 263911 | Plate, Lever Lock w/ Labels |
| 12 | 241831 | Label, High Speed Discharge 4" X 3" | 37 | 263921 | Hopper Assembly, w/ Labels |
| 13 | 111321 | Bolt, HCS, 5/16-18 X 4", GR5 | 38 | 247941 | Shield, Blow-Back |
| 14 | 263901 | Base, Weldment w/ Labels | 39 | 247931 | Support, Blow-Back Shield |
| 15 | 241801 | Label, Danger, Read Manual 4" X 2" | 40 | 200141 | Mount Plate, Blow-Back Shield |
| 16 | 256571 | Pulley, Idler | 41 | 114781 | Screw, PH 10-24 X 5/8" |
| 17 | 184511 | Spacer, .39" ID, .63" OD, .52" LG | 42 | 247961 | Label, Danger, Death/Injury 7.75" X 4" |
| 18 | 123341 | Bolt, HCS, 3/8-16 X 1- 3/4", GR5, ZP | | | |
| 19 | 247781 | Idler Arm, ATM Chip | | | |
| 20 | 247791 | Spring, Extension, 4", .135 " Wire Dia | <u>Not Illustrated</u> | | |
| 21 | 248021 | Bolt, Shldr, 5/16-18, 3/8" Dia X 7/8" | 112141 | | Cable Tie, 7-1/2" L |
| 22 | 110751 | Nut, Nylon Lock, 3/8-16 | 258991 | | Switch, Safety Key |
| 23 | 111521 | Bolt, HCS, 3/8-16 X 1", GR5, ZP | 370391 | | Harness, OPC Override, AT4 |
| 24 | 247831 | Bracket, Belt Release Lever | 370441 | | Key with Lanyard, OPC Override, AT4 |
| 25 | 247801 | Lever, Belt Release, ATM Chip | | | |

Schematic – FRAME ASSEMBLY

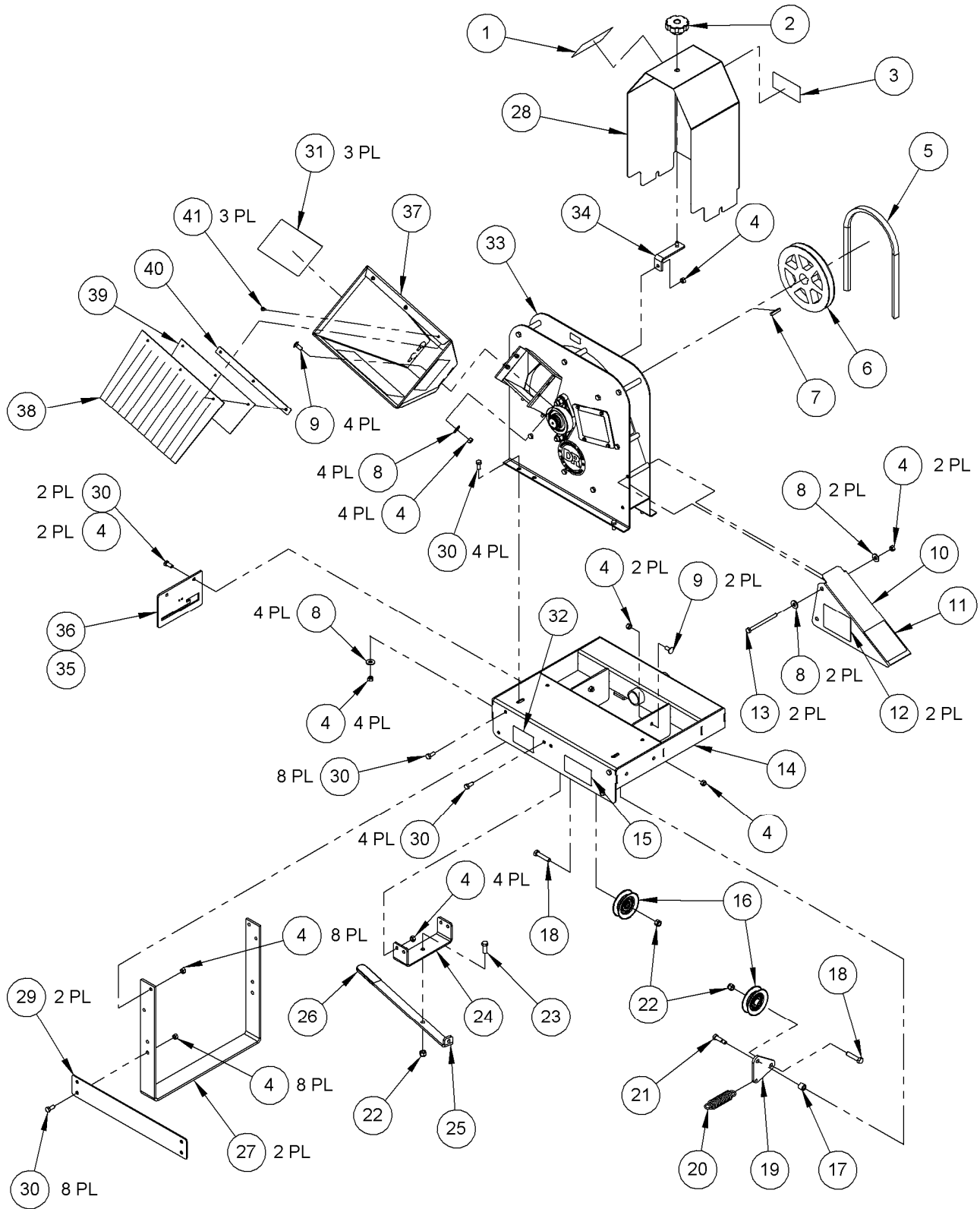

Parts List – CHIPPER BASIC

NOTE: Part numbers listed are available through DR Power Equipment.

| <u>Ref#</u> | <u>Part#</u> | <u>Description</u> | <u>Ref#</u> | <u>Part#</u> | <u>Description</u> |
|-------------|--------------|--|-------------------------------|--------------|---------------------------------------|
| 01 | 110761 | Nut, Nylon Lock. 5/16-18 | 15 | 192021 | Label, Dr Logo, 4" Round 4 Color |
| 02 | 256311 | Bearing, 2 Bolt, 1-3/16" | 16 | 110731 | Nut, Nylon Lock, 1/4-20 |
| 03 | 254521 | Shim, .120" | 17 | 112371 | Washer, Flat, 10-24 X 5/8" |
| 04 | 183011 | Ring, Retaining, 1-3/16" | 18 | 186041 | Plate, Wear |
| 05 | 229101 | Nut, Hex, 1/2-13", GR5, ZP | 19 | 157471 | Bolt, Carr, 1-4-20 X 1" |
| 06 | 112421 | Washer, Flat Lock, 1/2", USS | 20 | 222131 | Bolt HCS, 5/16-18 X 3-5/8", GR5, ZP |
| 07 | 167981 | Cover, Access | 21 | 263961 | Side Plate Weldment w/ Labels, Hopper |
| 08 | 155121 | Screw, Self Tap, 10-32 X 1" | 22 | 263971 | Scroll Weldment w/ Label |
| 09 | 247891 | Side Plate Weldment w/ Labels, Drive | 23 | 183131 | Spacer, Scroll Tube |
| 10 | 229091 | Bolt HCS, 1/2-13 X 1-1/2" | | | |
| 11 | 241991 | Label, Warning, Stop & Wait, 2.5" X 3" | <u>Not Illustrated</u> | | |
| 12 | 247871 | Chipper Disk Assembly, w/ Knife | | 197091 | Gauge, Knife Gap |
| 13 | 247971 | Label, Warning, Access Plate, 4" X 3" | | 200481 | Knife Kit, CPR |
| 14 | 263981 | Cover w/ Labels, Access | | | |

Schematic – CHIPPER BASIC

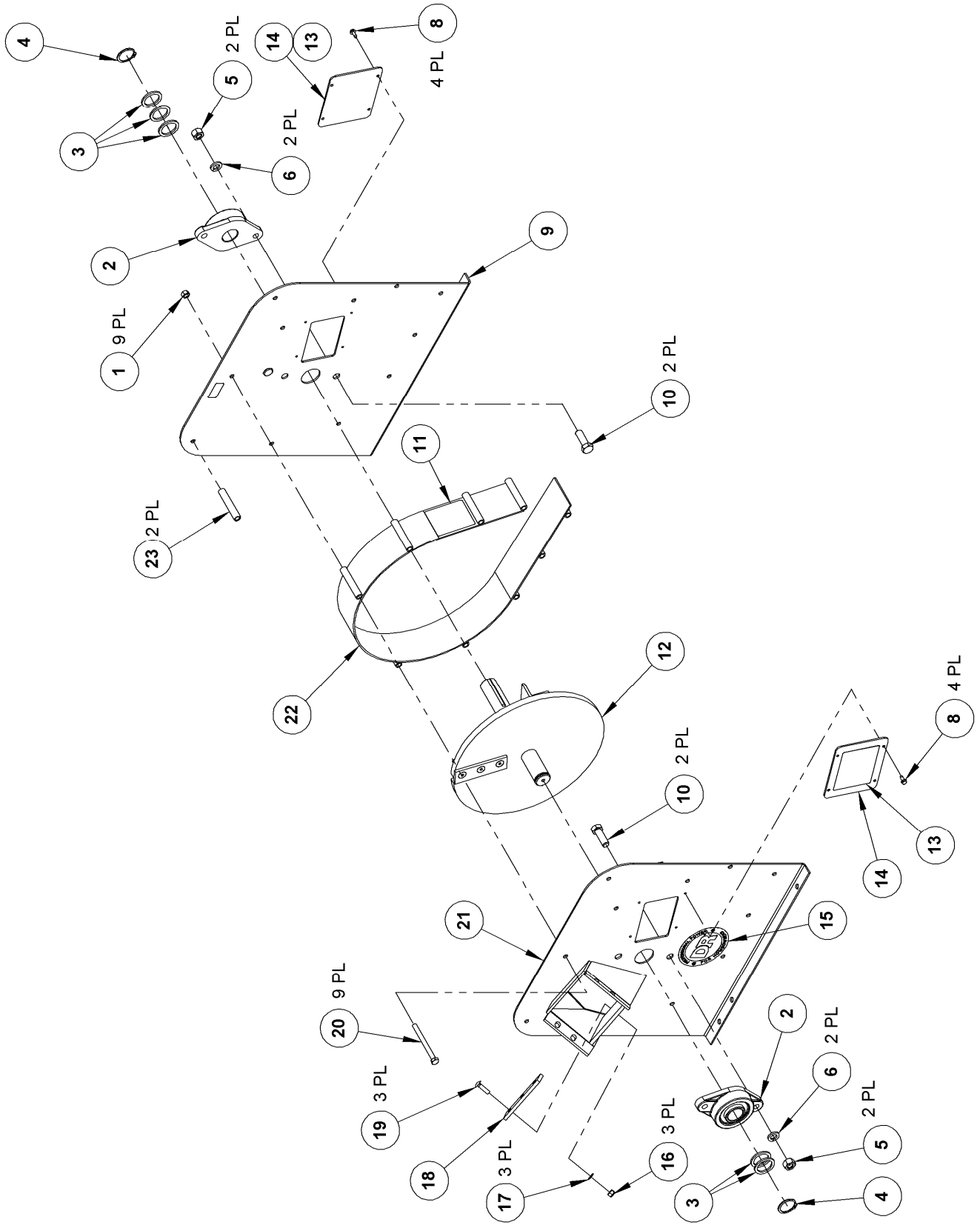

Daily Checklist for the DR CHIPPER ATTACHMENT

To help maintain your DR CHIPPER ATTACHMENT for optimum performance, we recommend you follow this checklist each time you use your Chipper.

WARNING

Disengage the blade at the control panel of the DR Field and Brush Mower. Shut down the engine, wait for all moving parts to come to a complete stop, remove spark plug wire keeping it away from the spark plug to prevent accidental starting, then wait 5 minutes before performing maintenance procedures or inspection on the chipper.

NOTE: Please refer to the DR Field and Brush Mower Safety and Operating Instructions manual for its daily checklist.

- [] **BELT:** Check the Belt for wear.
- [] **KNIFE and WEAR PLATE:** Check the Knife and Wear Plate for tightness, nicks, wear and proper gap.
- [] **GENERAL CONDITION:** Check the general condition of the machine, e.g.; nuts, bolts, welds, etc.
- [] **HOPPER:** Check that there is no material left in the hopper before starting the Chipper.
- [] **BEARINGS:** Check that Bearings have been greased.

End of Season and Storage

WARNING

- Disengage the blade at the control panel of the DR Field and Brush Mower. Shut down the engine, wait for all moving parts to come to a complete stop, remove spark plug wire keeping it away from the spark plug to prevent accidental starting, then wait 5 minutes before performing maintenance procedure or inspection on the Chipper.
 - When not in use, your DR CHIPPER ATTACHMENT should be stored out of the reach of children.
-

NOTE: Please refer to the DR Field and Brush Mower Safety and Operating Instructions manual for its storage requirements.

- Lubricate all grease fittings.
- Check the Drive Belt for wear.
- Check the Chipper Knife and Wear Plate for nicks and wear.
- Clean any debris from the Hopper and Discharge Chute.



75 MEIGS ROAD, P.O. BOX 25, VERGENNES, VERMONT 05491