

DR® STUMP GRINDER

SAFETY & OPERATING INSTRUCTIONS



Serial No. _____

Order No. _____

Original Language

DR Power Equipment
Toll-free phone: 1-800-DR-OWNER (376-9637)
Fax: 1-802-877-1213
Website: www.DRpower.com

! WARNING

Read and understand this manual and all instructions before operating the DR STUMP GRINDER.

Table of Contents

Chapter 1: General Safety Rules.....	3
Chapter 2: Setting Up The DR STUMP GRINDER	6
Chapter 3: Operating The DR STUMP GRINDER	11
Chapter 4: Maintaining The DR STUMP GRINDER.....	14
Chapter 5: Troubleshooting	22
Chapter 6: Parts Lists and Schematic Diagrams.....	24

Conventions used in this manual

WARNING

This indicates a hazardous situation, which, if not avoided, could result in death or serious injury.

CAUTION

This indicates a hazardous situation, which, if not avoided, could result in minor or moderate injury.

NOTICE

This information is important in the proper use of your machine. Failure to follow this instruction could result in damage to your machine or property.

Serial Number and Order Number

A Serial Number is used to identify your machine and is located on the Serial Number Label on your machine. An Order Number is used to check and maintain your order history and is located on the upper left portion of your packing slip. For your convenience and ready reference, enter the Serial Number and Order Number in the space provided on the front cover of this manual.

Additional Information and Potential Changes

DR Power Equipment reserves the right to discontinue, change, and improve its products at any time without notice or obligation to the purchaser. The descriptions and specifications contained in this manual were in effect at printing. Equipment described within this manual may be optional. Some illustrations may not be applicable to your machine.

Chapter 1: General Safety Rules

WARNING

Read this safety & operating Instructions manual before you use the DR STUMP GRINDER. Become familiar with the operation and service recommendations to ensure the best performance from your machine. If you have any questions or need assistance, please contact us at www.DRpower.com or call toll-free 1-800-DR-OWNER (376-9637) and one of our Technical Support Representatives will be happy to help you.

Labels

Your DR STUMP GRINDER carries prominent labels as reminders for its proper and safe use. Shown below are copies of all the Safety and Information labels that appear on the equipment. Take a moment to study them and make a note of their location on your STUMP GRINDER as you set up and before you operate the unit. Replace damaged or missing safety and information labels immediately.

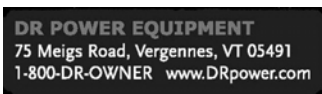

#23545

**WARNING: Check Oil
Before Starting Engine**

#13758

**THROTTLE
CONTROL**

#15345



#19320



#25709



#18887

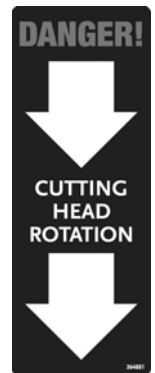

#26488

Protecting Yourself and Those Around You

WARNING

This is a high-powered machine, with moving parts operating with high energy. You must operate the machine safely. Unsafe operation can create a number of hazards for you, as well as anyone else in the nearby area. Always take the following precautions when using this machine:

- Keep in mind that the operator or user is responsible for accidents or hazards occurring to other people, their property, and themselves.
 - Always wear protective goggles or safety glasses with side shields while using the STUMP GRINDER to protect your eyes from possible thrown debris.
 - Avoid wearing loose clothing or jewelry, which can catch on moving parts.
 - We recommend wearing gloves while using the STUMP GRINDER. Be sure your gloves fit properly and do not have loose cuffs or drawstrings.
 - Wear shoes with non-slip treads when using your STUMP GRINDER. If you have safety shoes, we recommend wearing them. Do not use the machine while barefoot or wearing open sandals.
 - Wear long pants while operating the STUMP GRINDER.
 - Use ear protectors or ear plugs rated for at least 20 dba to protect your hearing.
 - Keep bystanders at least 50 feet away from your work area at all times. Stop the engine when another person or pet approaches.
-

Safety for Children and Pets

WARNING

Tragic accidents can occur if the operator is not alert to the presence of children and pets. Children are often attracted to the machine and the grinding activity. *Never* assume that children will remain where you last saw them. Always follow these precautions:

- Keep children and pets at least 50 feet from the working area and ensure they are under the watchful care of a responsible adult.
- Be alert and turn the machine off if children or pets enter the work area.
- Never allow children to operate the STUMP GRINDER.

Safety with Gasoline - Powered Machines

WARNING

Gasoline is a highly flammable liquid. Gasoline also gives off flammable vapor that can be easily ignited and cause a fire or explosion. Never overlook the hazards of gasoline. Always follow these precautions:

- Never run the engine in an enclosed area or without proper ventilation as the exhaust from the engine contains carbon monoxide, which is an odorless, tasteless, and deadly poisonous gas.
- Store all fuel and oil in containers specifically designed and approved for this purpose and keep away from heat and open flame, and out of the reach of children.
- Replace rubber fuel lines and grommets when worn or damaged and after 5 years of use.
- Fill the gasoline tank outdoors with the engine off and allow the engine to cool completely. Don't handle gasoline if you or anyone nearby is smoking, or if you're near anything that could cause it to ignite or explode. Reinstall the fuel tank Cap and fuel container cap securely.
- If you spill gasoline, do not attempt to start the engine. Move the machine away from the area of the spill and avoid creating any source of ignition until the gas vapors have dissipated. Wipe up any spilled fuel to prevent a fire hazard and properly dispose of the waste.
- Allow the engine to cool completely before storing in any enclosure. Never store a machine that has gas in the tank, or a fuel container, near an open flame or spark such as a water heater, space heater, clothes dryer or furnace.
- Never make adjustments or repairs with the engine running. Shut down the engine, disconnect the spark plug wire, keeping it away from the spark plug to prevent accidental starting, wait 5 minutes before making adjustments or repairs.
- Never tamper with the engine's governor setting. The governor controls the maximum safe operation speed and protects the engine. Over-speeding the engine is dangerous and will cause damage to the engine and to the other moving parts of the machine. If required, see your authorized dealer for engine governor adjustments.
- Keep combustible substances away from the engine when it is hot.
- Never cover the machine while the muffler is still hot.
- Do not operate the engine with the air cleaner or the carburetor air intake cover removed. Removal of such parts could create a fire hazard. Do not use flammable solutions to clean the air filter.
- The muffler and engine become very hot and can cause a severe burn; do not touch.

General Safety

WARNING

Operating this Stump Grinder safely is necessary to prevent or minimize the risk of death or serious injury. Unsafe operation can create a number of hazards for you. Always take the following precautions when operating this Stump Grinder:

- Your Stump Grinder is a powerful tool, not a plaything. Exercise extreme caution at all times. The machine is designed to grind stumps. Do not use it for any other purpose.
- Know how to stop the Stump Grinder quickly; see “stopping the engine” in chapter 3.
- Never operate your unit on a slippery, wet, muddy, or icy surface. Exercise caution to avoid slipping or falling.
- See manufacturer’s instructions for proper operation and installation of accessories. Only use accessories approved by DR Power Equipment.
- Never use the machine without ensuring that all guards and shields are in place.
- Never, under any conditions, remove, bend, cut, fit, weld, or otherwise alter standard parts on the Stump Grinder. This includes all shields and guards. Modifications to your machine could cause personal injuries and property damage and will void your warranty.
- Allow only one person to operate the Stump Grinder at any time.
- If the machine should start making an unusual noise or vibration, shut down the engine, disconnect the spark plug wire, keeping it away from the spark plug to prevent accidental starting, wait 5 minutes, then inspect for damage. Vibration is generally a warning of trouble. Check for damaged parts and clean, repair, and/or replace as necessary.
- Never tamper with safety devices. Check their proper operation regularly.
- Before performing any maintenance or inspection procedure on the Stump Grinder, release the throttle lever first and then release the operator presence lever, turn the ignition switch to “off”, remove the spark plug wire and keep it away from the spark plug.
- Never allow people who are unfamiliar with these instructions to use the Stump Grinder. Allow only responsible individuals who are familiar with these rules of safe operation to use your machine.
- Never overload or attempt to grind material beyond the manufacturer’s recommendation. Personal injury or damage to the machine could result.
- While using the Stump Grinder, don't hurry or take things for granted. When in doubt about the equipment or your surroundings, stop the machine and take the time to look things over.
- Never operate the machine when under the influence of alcohol, drugs, or medication.
- Use the machine only in daylight.
- Stay alert for hidden hazards or traffic.
- Keep all nuts and bolts tight and keep the equipment in good operating condition.

A Note to All Users

Under California law, and the laws of some other states, you are not permitted to operate an internal combustion engine using hydrocarbon fuels without an engine spark arrester. This also applies to operation on US Forest Lands. All DR® STUMP GRINDERS shipped to California, New Mexico and Washington State are provided with spark arresters. Failure of the owner or operator to maintain this equipment in compliance with state regulations is a misdemeanor under California law and may be in violation of other state and/or federal regulations. Contact your State Park Association or the appropriate state organization for specific information in your area.

No list of warnings and cautions can be all-inclusive. If situations occur that are not covered by this manual, the operator must apply common sense and operate this DR STUMP GRINDER in a safe manner. Contact us at www.DRpower.com or call 1-800-DR-OWNER (376-9637) for assistance.

Chapter 2: Setting Up The DR STUMP GRINDER

It may be helpful to familiarize yourself with the controls and features of your DR STUMP GRINDER as shown in Figure 1 before beginning these procedures. If you have any questions at all, please feel free to contact us at www.DRpower.com.

DR STUMP GRINDER Controls and Features (Manual Start)

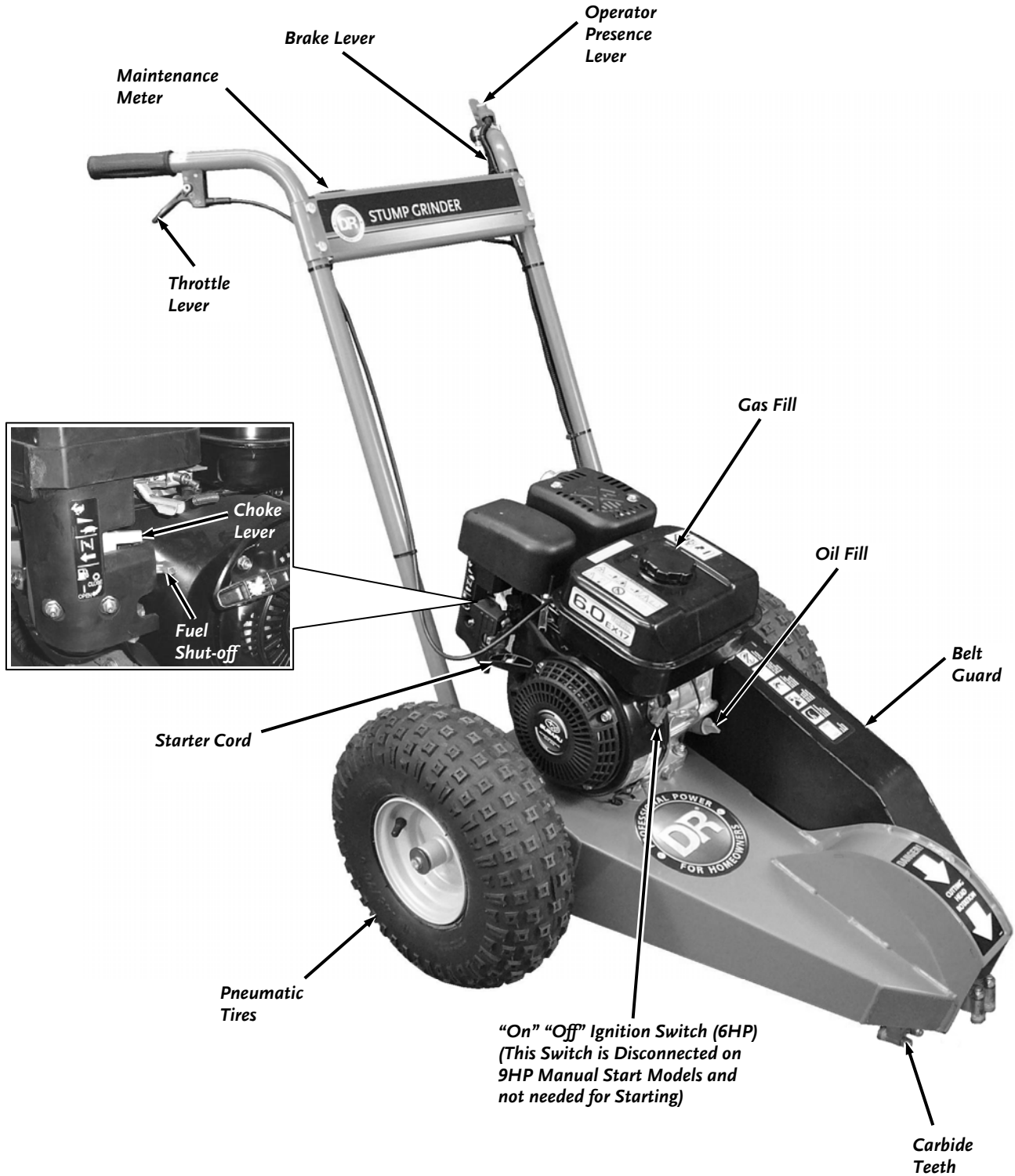

Figure 1a

DR STUMP GRINDER Controls and Features (Electric Start)

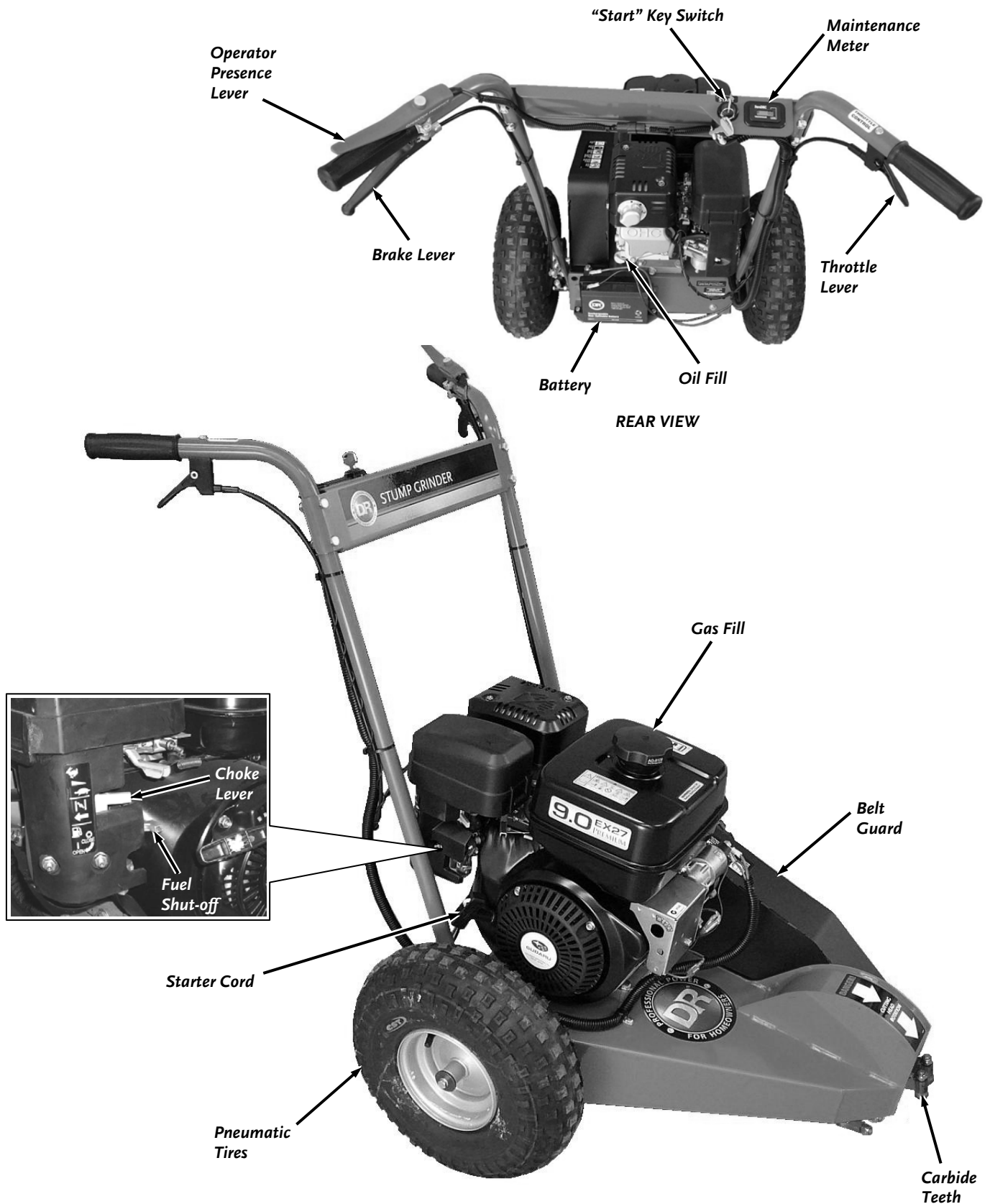

Figure 1b

Specifications

Engine	6HP Subaru Manual-Start	9HP Subaru Manual-Start	9HP Subaru Electric-Start
	Please refer to the Engine Owner's Manual for Engine-specifications.	Please refer to the Engine Owner's Manual for Engine-specifications.	Please refer to the Engine Owner's Manual for Engine-specifications.
Tire Size	14.5" Pneumatic	14.5" Pneumatic	14.5" Pneumatic
Handle Bars	Height adjustable to 32", 36.5" and 40" (w/tools)	Height adjustable to 32", 36.5" and 40" (w/tools)	Height adjustable to 32", 36.5" and 40" (w/tools)
Brake	Band w/ locking feature	Band w/ locking feature	Band w/ locking feature
Diameter	4"	4"	4"
Clutch	Centrifugal	Centrifugal	Centrifugal
Engagement speed	1900 RPMs	1900 RPMs	1900 RPMs
Frame	Welded 12 ga steel construction	Welded 12 ga. steel construction	Welded 12 ga. steel construction
Belt	V-Belt	V-Belt	V-Belt
Size	AP47: 49.3" OD, 47.3" ID	BP47: 49.8" OD, 47.3" ID	BP47: 49.8" OD, 47.3" ID
Construction	Wrapped for abrasion resistance	Wrapped for abrasion resistance	Wrapped for abrasion resistance
Cutting Head	Rotary 8 Tooth	Rotary 8 Tooth	Rotary 8 Tooth
Cutting Head Size (w/Teeth)	1.75" Wide (kerf) X 10.5" Diameter	1.75" Wide (kerf) X 10.5" Diameter	1.75" Wide (kerf) X 10.5" Diameter
Cutting Teeth	Replaceable Carbide Tipped (three position)	Replaceable Carbide Tipped (three position)	Replaceable Carbide Tipped (three position)
Machine Dimensions	28" W x 51" L x 36" H* - *center Handlebar position	28" W x 51" L x 36" H* - *center Handlebar position	28" W x 51" L x 36" H* - *center Handlebar position
Operating Weight	129 lbs	143 lbs	166 lbs
Shipping Weight	194 lbs.	210 lbs.	231 lbs.
Shipping Dimensions	54.75" L x 35.5" W x 45.25" H	54.75" L x 35.5" W x 45.25" H	54.75" L x 35.5" W x 45.25" H

Unpacking the DR STUMP GRINDER

Tools and supplies Needed:

- Wire Cutters
- Utility Knife
- Needle Nose Pliers
- Safety Glasses

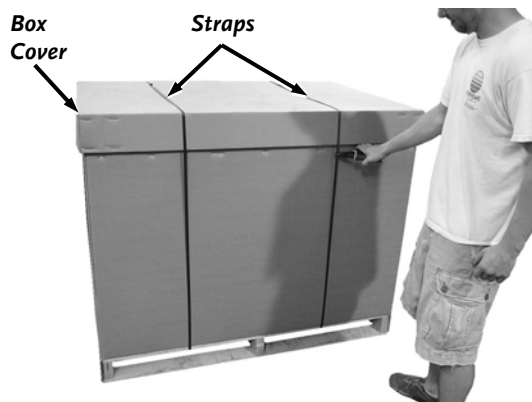

Figure 2

CAUTION

The Straps and Cable Ties may be under tension. Wear Safety Glasses when cutting the Straps and Cable Ties to protect your eyes.

1. Cut the two Straps securing the Box Cover and remove the Cover (**Figure 2**).

2. Pull the seams at the ends of the Box apart (you may need Needle Nose Pliers to loosen the staples) and lay the sides down (**Figure 3**).
3. Remove the Product Package (Safety and Operating Instructions manual and Engine manual) from the Control Panel by cutting the tape with a Utility Knife.
4. Cut all Plastic Straps that are securing the Stump Grinder to the Pallet, unlock the Brake by gripping the Brake Lever then releasing it and roll the Stump Grinder from the Pallet (**Figure 4**).

Do not discard the shipping materials until you are fully satisfied with your new DR® STUMP GRINDER.

Adding Oil and Gasoline

Engine Oil	SAE 30: above 50 degrees F; 10w-30: 10-90 degrees F; 5w-30: 30 degrees F or below
Fuel	Unleaded gasoline

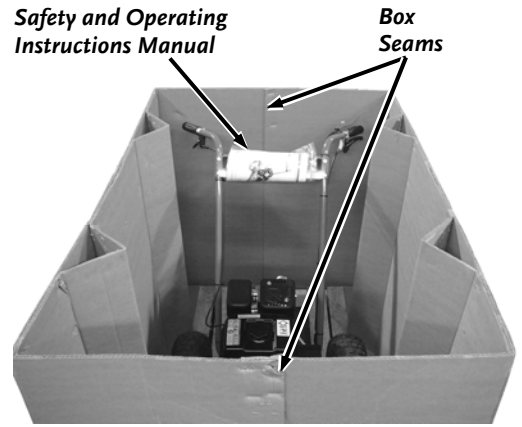

Figure 3

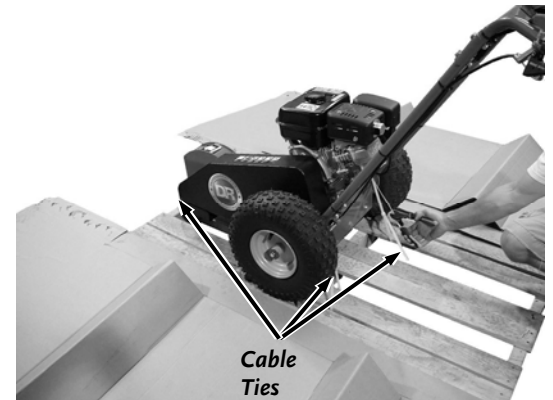

Figure 4

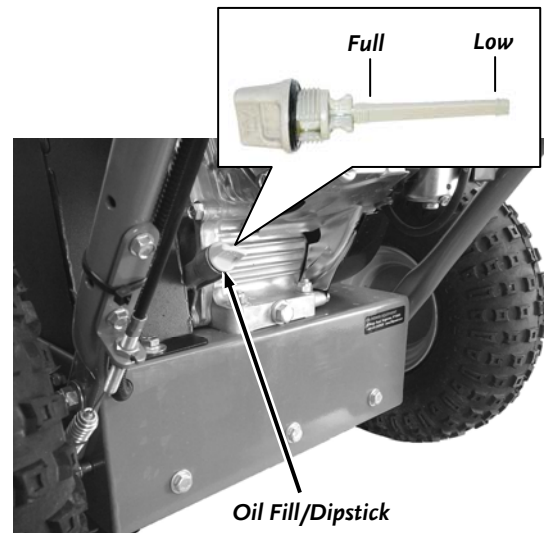

Figure 5

NOTICE

- You must add oil before starting the engine. This machine is shipped without oil. Traces of oil may be in the reservoir from factory testing, but you must add oil before starting the engine. Fill the reservoir slowly, checking the level frequently to avoid overfilling.
- To get an accurate reading when checking the oil level:
 - The Engine must be level.
 - The dipstick should not be screwed down to ensure an accurate oil level reading.

NOTE: Use only the recommended high detergent engine oil. Other types of oil could cause problems operating your machine. Please refer to your Engine Owner's Manual for detailed oil information.

1. Position the machine so the Frame and Engine are level. Remove the Oil Fill/Dipstick (**Figure 5**) and clean the end of it with a rag.

NOTICE

The Frame and Engine must be level to get an accurate reading when adjusting the oil level. Use blocks to adjust the height of the cutting head to level the Frame.

2. Machines are shipped with no oil. Initially add 16 oz. of the oil recommended by the Engine Manufacturer. Wait one minute for the oil to settle.
3. Replace the Dipstick, but **DO NOT** screw it in to ensure an accurate reading and then remove it to check the oil level (clean the Dipstick with the rag after checking).
4. Continue adding a few ounces of oil at a time, rechecking the Dipstick until the oil reaches the fill mark. Be careful not to overfill.
5. Replace the Dipstick and screw all the way down when full.

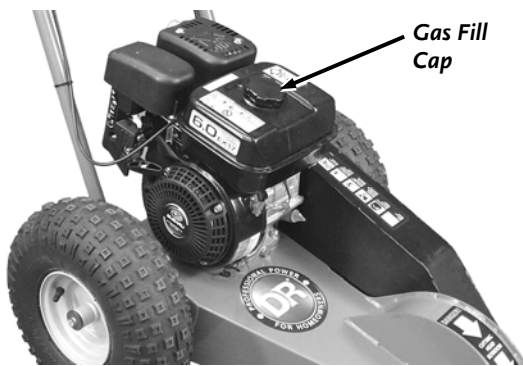

Figure 6

- Remove the Gas Fill Cap and fill the Gas Tank with fresh, unleaded gas (with a minimum of 85 Octane) to approximately 1" to 1-1/2" below the top of the fill neck to allow for fuel expansion (**Figure 6**). Be careful not to overfill and reinstall the Gas Fill Cap before starting the engine. See your Engine Owner's Manual for more detailed information.

NOTE: To refill the gas tank, turn the engine OFF and let the engine cool at least five minutes before removing the gas fill cap.

! WARNING

Remove any blocking used to level the Engine before operating the DR Stump Grinder.

Check the Tire Pressure

Tools Needed:

- Tire Pressure Gauge
- Air Compressor

- Remove the Valve Stem Protective Cap (**Figure 7**) and check the tire pressure with a Tire Pressure Gauge.
- Compare the tire pressure reading from step 1 with the manufacturer's recommended tire pressure stamped on the side of the tire.
- If the pressure is too low, add air through the Valve Stem with an air hose.

! WARNING

Do not over inflate the tires. Inflate to the manufacturers recommended pressure found on the tires.

- Replace the Valve Stem Protective Cap when finished.

Connect the Battery

NOTE: The Battery may have been shipped with a protective Cap over the negative Terminal and the Cap will need to be removed to connect the Negative Wire.

- Connect the Black Negative Terminal onto the negative Battery Lug (**Figure 8**).

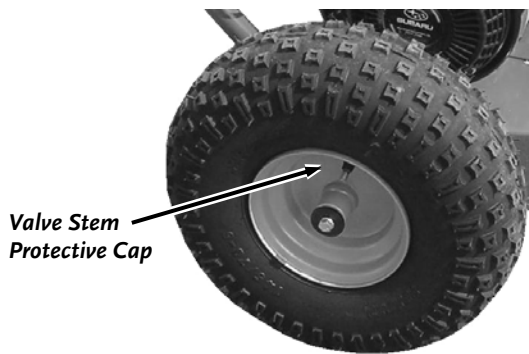

Figure 7

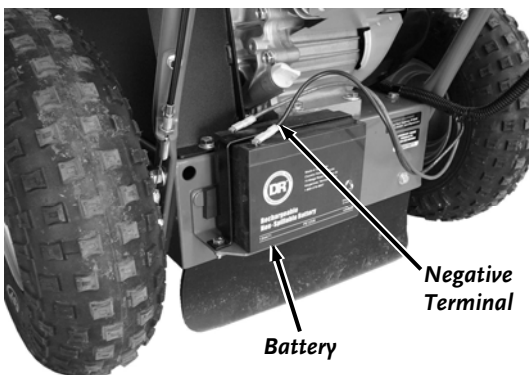

Figure 8

Chapter 3: Operating The DR STUMP GRINDER

It may be helpful to better familiarize yourself with the features of your Stump Grinder by reviewing **Figure 1** in Chapter 2 before beginning the steps outlined in this chapter.

⚠ WARNING

Read and understand the warnings listed in “Chapter 2 General Safety Rules” before operating this Stump Grinder.

Control Levers

1. Familiarize yourself with all of the Control Levers and their functions before operating the Stump Grinder (**Figure 9**).

Starting the Engine (Manual Start)

1. Turn the Ignition Switch to the “ON” position (**Figure 10**) (6HP only).
2. Make sure the Fuel Shut-off is in the “OPEN” position (**Figure 11**).
3. Move the Choke Control Lever to the left to the choke position (leave in the run position to the right if the engine is already warm).

NOTE: The Operator Presence Lever must be held down for the Engine to start and continue running. If you need to stop the machine quickly for any reason, let go of the Operator Presence Lever.

4. Hold down the Operator Presence Lever and slowly pull the Starter Cord until you feel resistance, then pull quickly. The Cord will recoil back into position.
5. As the engine warms up, slowly adjust the Choke to the right towards the run position. Wait until the engine runs smoothly before each Choke adjustment.
6. When the Engine is warmed up and running smoothly, ensure that the Choke is fully in the run position to the right.

Starting the Engine (Electric Start)

1. Make sure the Fuel Shut-off is in the “OPEN” position (**Figure 11**).
2. Move the Choke Control Lever to the left to the choke position (leave in the run position to the right if the engine is already warm).

NOTE: The Operator Presence Lever must be held down for the Engine to start and continue running. If you need to stop the machine quickly for any reason, let go of the Operator Presence Lever.

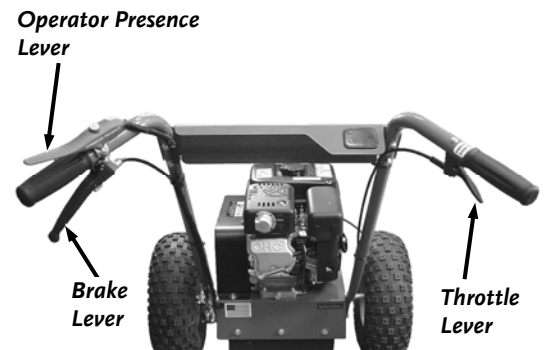

Figure 9

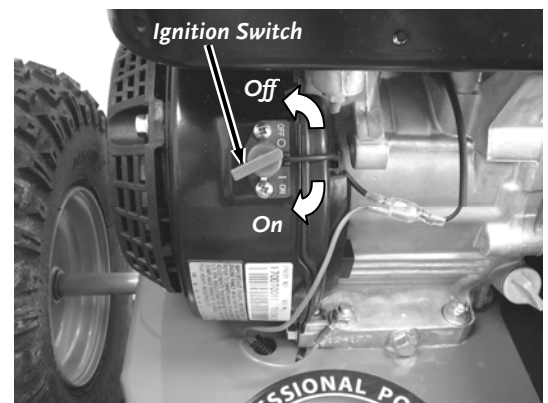

Figure 10

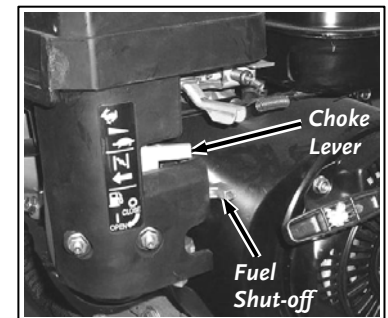

Figure 11

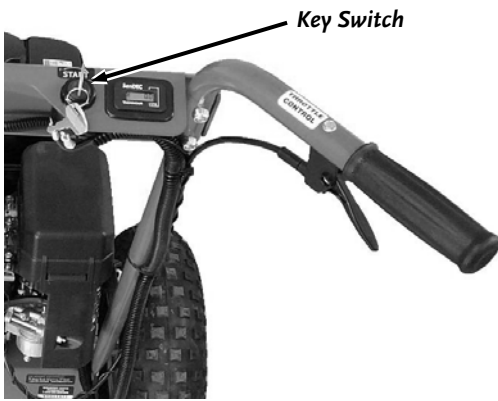

Figure 12

3. Hold down the Operator Presence Lever and turn the Key Switch fully to the “Start” position until the engine starts (**Figure 12**). The Key will move back a bit from the full Start position when released.
4. As the engine warms up, slowly adjust the Choke to the right towards the run position. Wait until the engine runs smoothly before each Choke adjustment.
5. When the Engine is warmed up and running smoothly, ensure that the Choke is fully in the run position to the right.

Stopping the Engine

1. Slowly release the Throttle Control Lever to the idle position (**Figure 9**).
2. Release the Operator Presence lever to stop the Engine.
3. Turn the Ignition Switch to the “Off” position (**Figure 10** for 6HP Manual Start) and to the left (**Figure 12** for 9HP Electric Start).

Before You Begin

- Dig away the earth and remove any stones near the tree stump that may interfere with your work.
- Check that the ground is free of foreign objects, such as electrical cables, barbed wire, etc.
- Cut the stump as close to the ground as possible using a Chainsaw before using the Stump Grinder.

Grinding Stumps

These grinding instructions are basic guidelines. Try different techniques in direction and depth of cut to determine what works best for your situation.

WARNING

Read and understand the warnings listed in “Chapter 2 General Safety Rules” before operating this Stump Grinder.

1. Start the Engine as described in the “Starting the Engine” section on page 11.
2. Allow engine to warm up at idle for a few minutes.
3. Move the Stump Grinder into position with the Cutter Head at the right side of the stump on the edge closest to you (not touching) near the top edge (**Figure 13**).
4. Lock the Hand Brake by pulling the Brake Lever, sliding the Lock forward and releasing the Lever.

NOTICE

Always make sure the Teeth are not in contact with anything before operating the Throttle Lever. The Clutch will be damaged if the teeth are not free to turn as you start to press the Throttle.

5. Fully Squeeze the Throttle Lever on the right side Handlebar (this will engage the Cutter Head Rotation). Let the Cutter Head come up to speed.
6. Lower the Cutter Head approximately 1/2" to 1" into the front-top corner of the stump and slowly swing the Cutter Head to the left into the stump by pushing on the right hand handlebar (**Figure 14**). When you are finished with the first pass through the Stump, swing the Cutter Head back to the starting position on the right side. Lower the Cutter Head approximately 1/2" to 1" and slowly swing the Cutter Head to the left through the Stump. Continue this process until you have removed the front portion of the stump to ground level.

NOTICE

If the Engine bogs down, lift the Cutting Head away from the stump to allow the Cutting Head to come back up to speed before further cutting.

7. Swing the Cutter Head over to the right side (**Figure 15** arrow #1), advance the machine forward (arrow #2) by releasing and resetting the brake. The machine should only be advanced far enough to engage the Cutter Head into the stump so that when swept across the stump it will remove 1/2" to 1" of stump with each sweep.
8. Sweep the Cutter Head across the stump, cutting away 1/2" to 1" of stump.
9. Continue cutting and advancing until the top level of stump is all removed, making sure not to cut the stump deeper than ground level during this first stage.
10. Release the Throttle Lever and then the Operator Presence Lever to stop the Engine and wait ten seconds for Cutter Head to stop rotating.
11. Release the Brake so you can pull the machine away from the stump and remove the chips/debris and any dirt away from the stump.
12. Repeat steps 1 through 11 until the stump is removed to the desired depth.

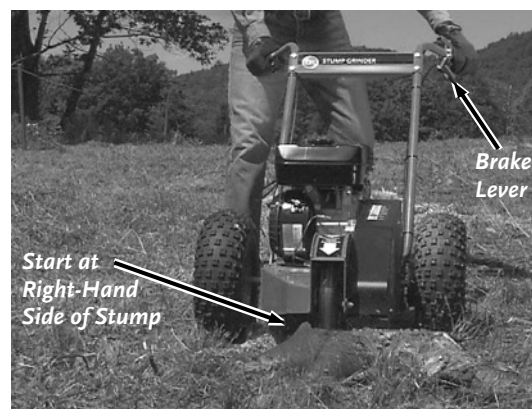

Figure 13

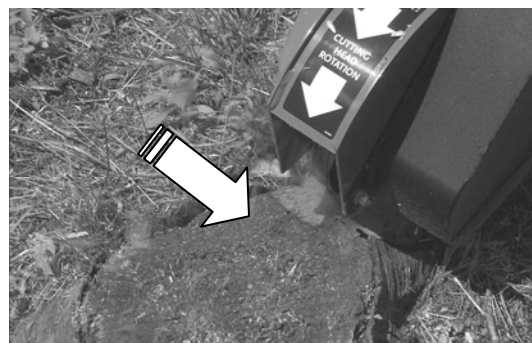

Figure 14

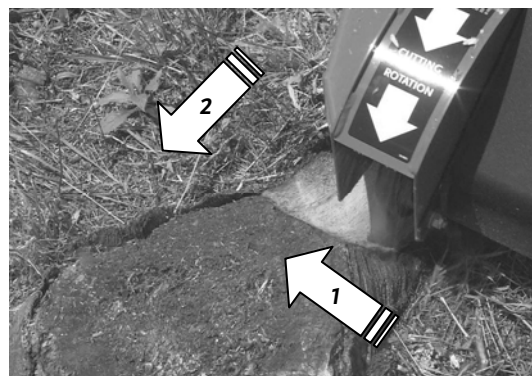

Figure 15

Chapter 4: Maintaining The DR STUMP GRINDER

Regular maintenance is the way to ensure the best performance and long life of your machine. Please refer to this manual and the engine manufacturer's owner's manual for maintenance procedures. Service intervals listed in the checklist below supersede those listed in the engine manufacturer's owner's manual.

⚠ WARNING

Before performing any maintenance procedure or inspection, stop the engine, wait five (5) minutes to allow all parts to cool. Disconnect the spark plug wire, keeping it away from the spark plug. Disconnect the Battery Terminals (Electric start only).

Regular Maintenance Checklist

PROCEDURE	BEFORE EACH USE	EVERY 25 HOURS	EVERY 60 HOURS	EVERY 100 HOURS
Check Engine Oil Level	▲			
Check General Equipment Condition	▲			
Check Cutting Teeth (are they dull or damaged)	▲			
Clean Engine Exterior & Cooling Fins	▲			
Remove debris wrapped around Cutter Head for Bearing protection.	▲			
Check Tire Pressure		▲		
Replace Belt if stretched or worn		▲		
Clean Air Filter		▲		
Lubricate Cables (SAE 30 Oil)		▲		
Change Engine Oil	1 st time 5 hours	▲		
Replace Cutting Teeth (or sooner if dull or damaged)		▲		
Check Cutter Head when Teeth are replaced		▲		
Replace Cutter Head (order kit # 30506)			▲	
Replace Spark Plug				▲
Replace Air Filter				▲

Removing and Replacing the Engine Oil

Tools and Supplies Needed:

- 14mm Wrench
- 1/2" Wrench (electric start only)
- Rags and approved Container (for waste oil)
- Small funnel
- Engine Oil (see your Engine Manual for Oil specifications)

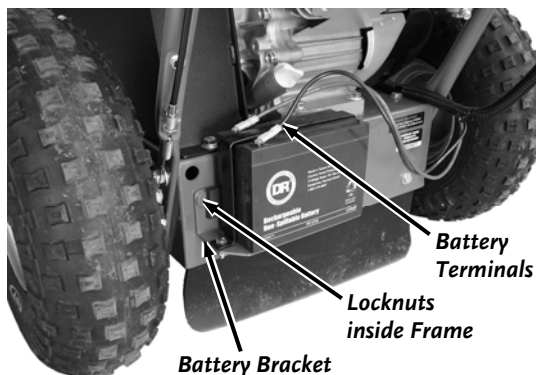

Figure 16

NOTICE

The Frame and Engine must be level to get an accurate reading when adjusting the oil level. Use blocks to adjust the height of the cutting head to level the Frame.

1. For Electric Start machines you will first need to disconnect the Battery Terminals and remove the Battery Bracket by removing the two Locknuts from the Bracket Studs with a 1/2" Wrench (leave Battery attached to Bracket) (Figure 16).

2. Position the machine so the Frame and Engine are level and place a Waste Oil Container under the Oil Drain Plug (**Figure 17**).
3. Remove the Oil Drain Plug with a 14mm Wrench and let the Oil drain into the Container.
4. Replace the Oil Drain Plug and remove the Oil Fill/Dipstick.
5. Initially add 16 oz. of oil (type of oil recommended by the Engine Manufacturer) into the Oil Fill and wait one minute for the oil to settle.
6. Check the Dipstick and continue adding a few ounces of oil at a time, rechecking the Dipstick until the oil reaches the fill mark. Be careful not to overfill.
7. Replace the Battery Bracket for electric start machines and reconnect the Battery.

Replacing the Belt

Tools and Supplies needed:

- Two 1/2" Wrenches
- 9/16" Wrench
- New DR Drive Belt (see chapter 6 for part numbers)
- Gloves

1. Remove the Bolt, Lock Washer and Flat Washer from the rear of the Belt Guard with a 1/2" Wrench (**Figure 18**).
2. Slightly loosen the Bolt, Washers and Lock Nut at the front of the Belt Guard with two 1/2" Wrenches and rotate the Guard forward.

NOTE: You may need to pull out on the bottom edge of the Guard as you rotate the Belt Guard to clear the Frame.

3. You should wear Gloves as you position a 9/16" Wrench onto the Idler Pulley Bolt and inline with the Pulley Bracket (**Figure 19**). Pull the Wrench to rotate the Belt Tensioner away from the Belt and then remove the Belt from under the Idler Pulley.
4. Roll the Belt off the top of the Clutch Pulley by rotating the Cutting Head in the reverse direction as you guide the Belt off to the side at the top of the Pulley. Remove the Belt from around the Cutting Head Pulley.
5. Reverse the previous steps to install the new Belt and reinstall the Belt Guard.

NOTE: When installing the Belt onto the Clutch Pulley, Start the Belt onto the bottom of the Pulley and rotate the Cutting Head forward as you guide the Belt up over the top of the Pulley.

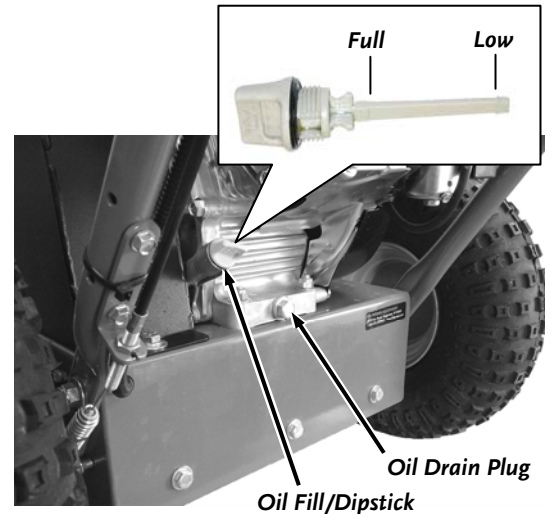

Figure 17



Figure 18

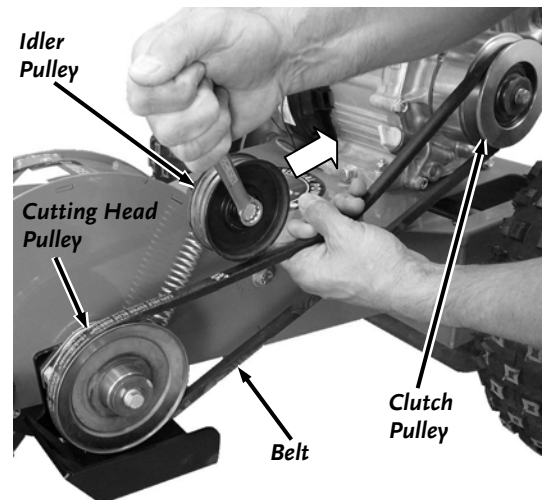

Figure 19

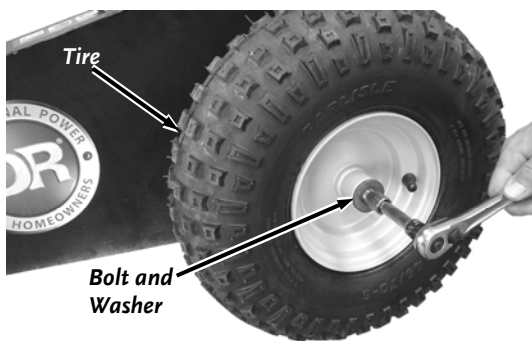

Figure 20

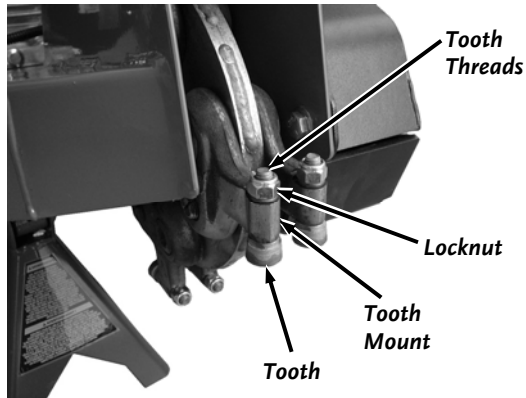

Figure 21

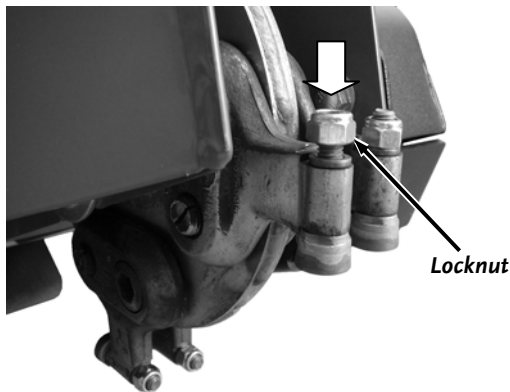

Figure 22

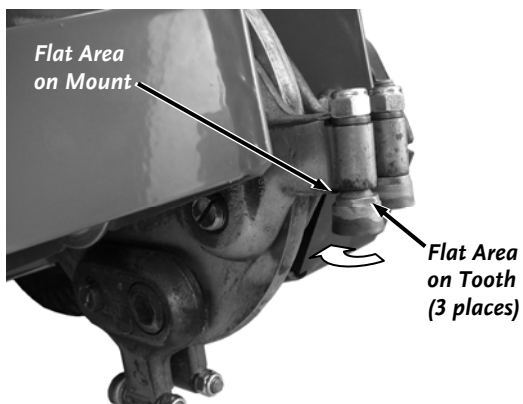

Figure 23

Replacing the Wheels

Tools and Supplies needed:

- 1/2" Wrench
- Jack Stand or Block

1. With the Stump Grinder on the ground, remove the Bolt, Lock Washer and Large Flat Washer from the Axle with a 1/2" Wrench (**Figure 20**).
2. Block the Stump Grinder up so the Wheels are off the ground and remove the Wheel.

NOTE: The Wheel on the right hand side has a Bushing in each end of the Wheel Hub (make sure the Bushings are in place when installing the Wheel). The left hand Wheel has a Keyway built in with a key to hold it from spinning when the Brake is applied (make sure the Key is installed in the slot when installing the Wheel).

3. Reinstall the Wheel and secure with the Bolt, Lock Washer and large Flat Washer using a 1/2" Wrench.

Rotating the Teeth (from dull to sharp edge)

Tools and Supplies needed:

- 1/2" Wrench
- Dead Blow Hammer
- Gloves

CAUTION! Wear Gloves when working near the teeth. Without Gloves your hands may get cut from the sharp edges.

1. Block the front end of the Stump Grinder so the Cutter Head is just off the ground.

Note: It may help to mark the "Dull" cutting edge prior to rotating the Teeth so you can be sure you have rotated to an unused cutting edge.

2. Loosen the Locknut on the Tooth until the top of the Locknut is flush with the top of the Tooth threads (**Figure 21**).
3. Lightly tap on the top of the Locknut with a Dead-blow Hammer so the Tooth will drop down away from the Tooth Mount (**Figure 22**).
4. Rotate the Tooth until the next flat area on the side of the Tooth is aligned with the flat area of the Mount (**Figure 23**).
5. After the tooth has been turned to the desired position push the Tooth up into the Mount and tighten the Locknut. There are no torque specification needed for the Locknut, but make sure you tighten them firmly.
6. Repeat steps 2-5 for the remaining Teeth as needed.

Replacing the Cutting Teeth

Tools and Supplies needed:

- 1/2" Wrench
- 1/2" Socket
- Torque Wrench
- Dead Blow Hammer
- Gloves

CAUTION! Wear Gloves when working near the teeth. Without Gloves your hands could suffer cuts from the sharp Teeth.

1. Block the front end of the Stump Grinder so the Cutter Head is just off the ground.
2. Remove the Locknut from the tooth threads (**Figure 24**).
3. Lightly tap on the top of the Tooth Threads with a Dead-blow Hammer to remove the Tooth from the Tooth Mount.

Note: In the next step make sure that the flat spot on the mount and one of the flat spots on the Tooth are aligned properly before tightening the Tooth hardware. Ensure that the Spacer Stays in position at the Locknut end of the Tooth.

4. Insert a new Tooth into the Mount and hold it up into position in the Mount as you secure with a new Locknut. Torque the Locknut to 20 ft. lbs.
5. Repeat steps 2 through 4 for the remaining Teeth as needed.

CAUTION! Check wear of the Head Assembly each time the Teeth are replaced. Replace the Head Assembly if it is damaged or worn. Ensure that all parts are secure and tight. Large Allen Head Bolts should be at 180 ft. lbs. torque.

Be sure to use the new Locknuts provided with the replacement teeth.

Failure to replace the Head Assembly when damaged or worn may result in Cutting Teeth coming loose and damaging the machine.

The Locknuts should be snug, but do not over tighten.

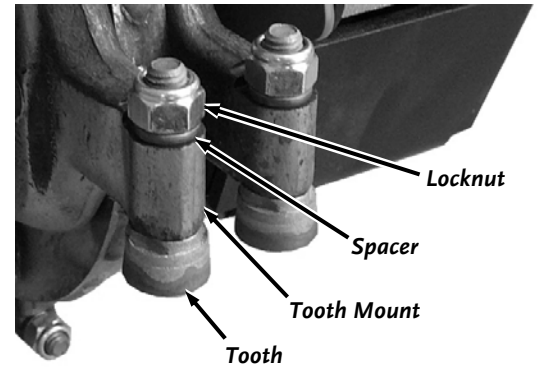

Figure 24

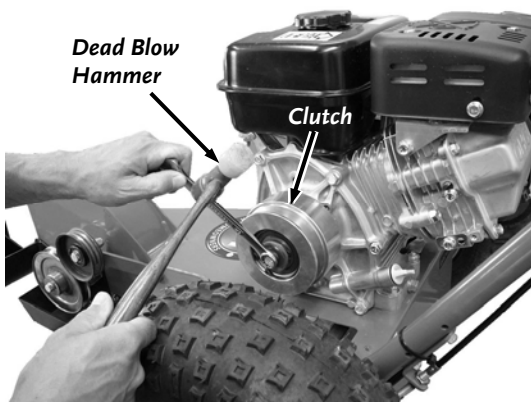

Figure 25

Replacing the Clutch

Tools and Supplies needed:

- 1/2" Wrench (6HP)
- 5/8" Wrench (9HP)
- Never Seize type Grease
- Dead Blow Hammer

1. Place a 1/2" Wrench (6HP) or 5/8" Wrench (9HP) onto the Clutch Bolt and rotate the Wrench counterclockwise until you feel some resistance (**Figure 25**).
2. Hit the Wrench with a Dead Blow Hammer to start the Bolt turning on the Engine Shaft.
3. Remove the Bolt, Lock Washer, Large Flat Washer and Clutch (with Key) from the Engine Shaft.
4. Apply a never seize type grease to the Engine Shaft and install the new Clutch and Key (align the Clutch Key Slot with the Key on Engine Shaft) and secure with the Bolt, Lock Washer and Large Flat Washer using a 1/2" Wrench (6HP) or 5/8" Wrench (9HP).

Lubricate Cables

Supplies needed:

- SAE 30 Oil

1. Lubricate the upper ends of the Throttle and Brake Cables with SAE 30 Oil where the cable goes into the sheathing.
2. Work the Cable Levers to work the Oil in between the Cable and Sheathing.

Adjusting the Handlebars

Supplies needed:

- Two 9/16" Wrenches
- 1/2" Wrench

1. Remove the left Wheel as described in the "Replacing the Wheels" section.

NOTE: The Brake Lever can be locked to aid in loosening the Hardware in the next step, but must be unlocked to remove the Brake Drum.

2. Remove the four Bolts, Lock Washers and Flat Washers from the Brake Drum with a 1/2" Wrench and pull the Drum from the Axle (**Figure 26**).
3. Remove the bottom Bolt, Flat Washers and Locknuts from both Handlebars with two 9/16" Wrenches and just loosen the upper Hardware (**Figure 27**).
4. Rotate the Handlebars forward to adjust them higher or back to make them lower and align with the holes in the Frame.
5. Reinstall the bottom Bolt, Flat Washers and Locknuts into both Handlebars and tighten all Handlebar Hardware with two 9/16" Wrenches.
6. Reinstall the Brake Drum and Wheel on the left side of the machine.

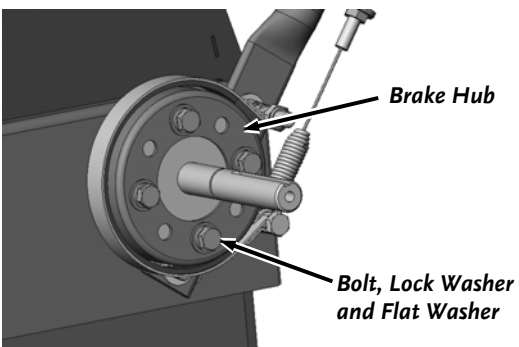

Figure 26

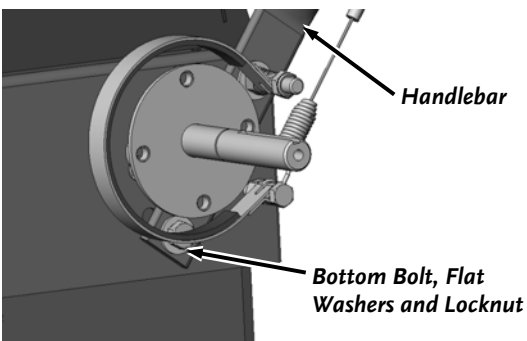

Figure 27

NOTICE

When the Handlebars are adjusted to the highest setting, you should change the position of the Exhaust Deflector so it is oriented 45° downward to the left so it is not pointing directly at the Handlebar. The paint may be damaged if the Deflector is not rotated.

Adjusting The Brake

Tools and supplies needed:

- 1/2" Wrench
- Blocking Material

NOTE: You must block the machine up so the left-side Wheel is just off the ground and can rotate freely to perform the following steps.

Tightening the Brake Cable (if the Brake does not hold the Wheel in place)

1. Loosen the lower nut a few turns so it moves away from the Bracket (**Figure 28**).
2. As you rotate the Wheel forward (with Wheel Lever unlocked), tighten the upper Nut until you feel a slight resistance at the Wheel.
3. Tighten the lower Nut up against the Bracket.
4. Lower the Stump Grinder to the ground and test the Brake and pivoting (side to side) action.
5. If the left-side Wheel rotates forward while the Brake Lever is locked, the Cable needs more tightening. Repeat steps above as needed.

NOTE: When the Cable is adjusted correctly and the Brake Lever is locked, the left-side Wheel will still rotate in reverse (towards the operator) with some effort, but should not rotate forward.

Loosening the Brake Cable (if the Brake does hold the Wheel in place, but pushing the machine with the Brake off is difficult)

1. As you rotate the Wheel forward (with Wheel Lever unlocked), loosen the upper Nut until the Wheel turns more freely but you still feel a slight resistance at the Wheel (**Figure 28**).
2. Tighten the lower Nut up against the Bracket.
3. Lower the Stump Grinder to the ground and test the Brake and pivoting (side to side) action.
4. If the left-side Wheel holds when the Brake is applied, but the machine is hard to push ahead when the Brake is released, the Cable needs more loosening. Repeat steps above as needed.

Adjusting The Throttle Linkage

Over time friction may increase in the Throttle Linkage. If the throttle lever does not return fully to low idle the throttle Pivot Nut may need adjustment.

Tools needed:

- 10mm Socket
- Ratchet and Extension

1. Loosen the Throttle Pivot Nut 1/4 turn counterclockwise and test the Throttle Lever (**Figure 29**). If the Throttle Lever fully returns to low idle, it is working properly. If there is still some hesitation of the Throttle Lever fully returning to low idle, turn the Throttle Pivot Nut another 1/4 turn and retest as needed.

NOTE: The Throttle Pivot Nut should not be loosened to the point that the Throttle Linkage is too loose (has excessive play). If the problem persists please contact us at www.DRpower.com or call 1-800-DR-OWNER (376-9637) for assistance.

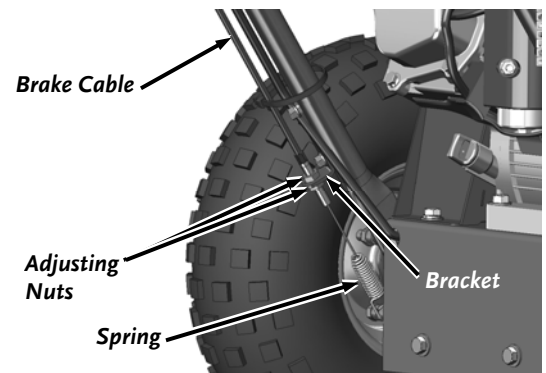

Figure 28

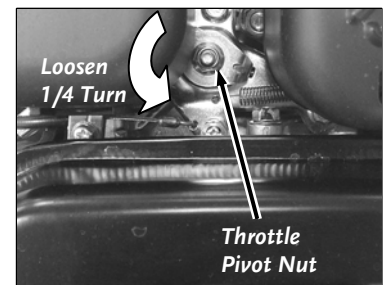

Figure 29

Battery Care (For Electric-Starting Models Only)

Proper care can extend the life of a Battery. Follow these recommendations to ensure your Battery's best performance and long life:

- Do not allow the Battery charge to get too low. If the machine is not used, charge the Battery every 4 – 6 weeks. Operate the engine for at least 45 minutes to maintain proper Battery charge.
- Store an unused Battery in a dry environment with temperatures between +40°F (+5°C) and +95°F (+35°C). Make sure the storage temperatures will never be outside of these limits. The lower the storage temperature is within the specified temperature, the better as the battery will discharge more slowly at low temperatures.
- Do not charge an already charged Battery. In theory, you cannot overcharge our Battery with a trickle charger; however, when a Battery is fully charged and the charger is still on, it generates heat that could be harmful to the Battery. A fully charged Battery will read 12V-13.2V with a voltmeter.
- Do not continue to crank your Engine when the Battery charge is low.

Charging the Battery

NOTICE

When you are finished charging the battery, disconnect the charger from the outlet first, then disconnect the battery charger wires from the battery. If you leave the battery charger wires connected to the battery, the battery will discharge itself back into the charger.

Operate the Engine for at least 45 minutes to maintain proper Battery charge. If the Battery loses its charge, you will need to use a trickle charger (like the DR Battery Charger) to recharge it. The Charger should have an output of 12 volts DC at no more than 2 amps.

- At 1 amp the Battery may need to be charged for as long as 48 hours.
- At 2 amps, the Battery may need to be charged for as long as 24 hours.

NOTE: *Using the Recoil Starter and then running the Engine will not recharge a dead or significantly discharged Battery.*

To connect a Battery Charger to your DR STUMP GRINDER, follow the steps listed below.

1. Attach the Black (-) alligator clipped wire from the Charger Adapter to the Negative (-) terminal of the Battery, then attach the Red (+) alligator clipped wire to the Positive (+) Battery terminal.
2. Plug the Charger into a standard wall outlet.
 - Typically, the Battery takes between 6 and 8 hours to fully charge. Do not leave the charger on the battery longer than 24 hours for a 2 amp charger, or 48 hours for a 1 amp charger as you could potentially damage the battery..
 - You can charge the Battery many times. The Battery lasts longer if you charge it before it is fully drained. Keep it fully charged and at room temperature when not using your DR STUMP GRINDER.
 - If the Battery does not hold its charge for very long under normal conditions or it simply won't hold a charge, then replace it. You can purchase replacement Batteries directly from us. To install your new Battery, follow the directions on the next page.

Replacing the Battery

Tools Needed:

- Two 7/16" Wrenches

1. Disconnect the Battery Terminals (**Figure 30**).
2. Remove the Bolts and Locknuts that secure the Battery Clamp using two 7/16" Wrenches.
3. Remove the Clamp and the dead Battery.
4. Install the new Battery.
5. Install the Battery Clamp and secure with the Bolts and Locknuts using two 7/16" Wrenches.
6. Attach the Battery Terminals. Black Wire to negative black Terminal and Red Wire to positive red Terminal.

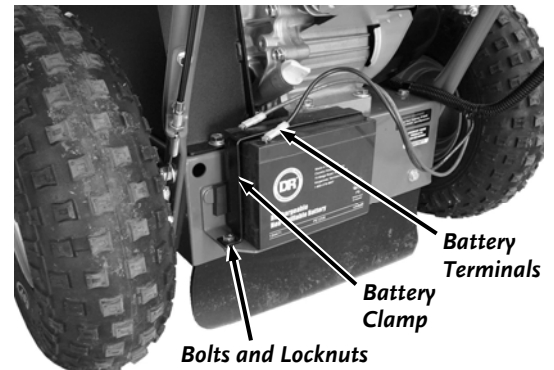

Figure 30

Disposing of the Battery Responsibly (Electric-Start Models)

The Battery is a sealed lead-acid Battery. Recycle or dispose of it in an environmentally sound way.

- Do not dispose of a lead-acid Battery in a fire; the Battery may explode or leak.
- Do not dispose of a lead-acid Battery in your regular, household trash. Law in most areas prohibits incinerating, disposing in a landfill, or mixing a sealed lead-acid Battery with household trash.

Recycling a Used Battery

Please dispose of your used Batteries responsibly by recycling them. Call your local Solid Waste Management District or your local waste handler to locate the collection site nearest you. Some collection sites recycle Batteries year-round; others collect them periodically.

You can also visit the Web site of Earth 911 for more information [www.earth911.org].

For a fee, you can recycle your Batteries with the International Metals Reclamation Company. Visit them at www.inmetco.com and click Services; or contact them at:

INMETCO
One INMETCO Drive
Ellwood City, PA 16117
(724) 758-2800; fax (724) 758-2845

To learn more about hazardous waste recycling, visit the Web site for Battery Council International [www.batterycouncil.org] or for the Environmental Protection Agency [www.epa.gov].

Chapter 5: Troubleshooting

Most problems are easy to fix. Consult the Troubleshooting Table below for common problems and their solutions. If you continue to experience problems, contact us at www.DRpower.com or call toll-free 1-800-DR-OWNER (376-9637) for support.

WARNING

Set the Wheel Brake, shut down the engine, remove the spark plug wire and wait 5 minutes before performing any maintenance procedure or inspection on the Stump Grinder.

Troubleshooting Table

SYMPTOM	POSSIBLE CAUSE
<i>Recoil will not pull out or is difficult to pull.</i>	<ul style="list-style-type: none"> ⇒ There may be an oil compression lock in the cylinder. Take out the Spark Plug; hold a rag over the Spark Plug hole and pull the Recoil Cord several times to blow out any oil in the Cylinder. Wipe off the Spark Plug and reinstall it. ⇒ Check the Engine oil level; the Engine may be seized. ⇒ The Recoil may be broken or jammed. Visit our website at www.DRpower.com.
<p><i>The Engine will not start.</i></p> <p><i>(Please refer to the Engine Owner's Manual for Engine-specific procedures.)</i></p>	<ul style="list-style-type: none"> ⇒ Make sure the Operator Presence Lever is held down and that the Ignition Switch is in the RUN position (Manual Start), or the Key is inserted into the Key switch and rotated to the right (Electric Start). ⇒ Check the oil and gas level. ⇒ Make sure that the Fuel Shut-Off is in the ON position. ⇒ Check that the Spark Plug Wire is attached. ⇒ The Air Filter may be dirty; change it following the procedure in the Engine Owner's Manual. ⇒ The gas may be old; change it if necessary. Use a fuel stabilizer if you keep gas longer than one month. ⇒ Check the Throttle and Choke settings, adjustment and travel. ⇒ The Spark Plug may be dirty or cracked; change it if necessary. If it's oily, leave it out, hold a rag over the Plug Hole and pull the Recoil Cord several times to blow out any oil in the Cylinder, then wipe off the Plug and reinsert it. ⇒ Check the wire connections—especially the ground connections to the Engine and the Starter connections. Check to be sure that all of the connections are clean and tight. ⇒ The Battery may not be charged. Check the voltage yourself or at a Service Station. If it is low, charge it with a 12-volt, 1 to 2 amp trickle Charger. If you do not use your machine for at least 45 minutes at a time, the Battery may need to be periodically charged. See the "Battery Care" section in Chapter 4. ⇒ If your Engine still won't start, visit our website at www.DRpower.com.
<p><i>The Engine lacks power or is not running smoothly.</i></p> <p><i>(Please refer to the Engine Owner's Manual for engine-specific procedures.)</i></p>	<ul style="list-style-type: none"> ⇒ Make sure the Choke Lever is all the way off. ⇒ The Air Filter may be dirty; change it following the procedure in the Engine Owner's Manual. ⇒ The Spark Plug may be dirty or cracked; change it if necessary. ⇒ The gas may be old; change it if necessary. Use a fuel stabilizer if you keep gas longer than one month. ⇒ The Engine oil may be dirty. Change it if necessary. ⇒ Check that the Cooling Fins are clean and free of debris. Clean as needed. ⇒ If your Engine still lacks power, visit our website at www.DRpower.com.

Troubleshooting Table (Continued)

WARNING

Set the Wheel Brake, shut down the engine, remove the spark plug wire and wait 5 minutes before performing any maintenance procedure or inspection on the Stump Grinder.

SYMPTOM	POSSIBLE CAUSE
<i>Engine smokes.</i>	<ul style="list-style-type: none"> ⇒ Check the oil level and adjust as needed. ⇒ Clean the Engine cooling fins and the carburetor housing if they are dirty. ⇒ The Air Filter may be dirty; change it following the procedure in the Engine Owner's Manual. ⇒ You may be using the wrong oil. Refer to your Engine Owner's Manual for detailed information. ⇒ If the Engine still smokes, visit our website at www.DRpower.com.
<i>The Engine runs well but the Cutting Head won't move.</i>	<ul style="list-style-type: none"> ⇒ The Throttle should be fully pressed to engage Clutch. ⇒ The Cutter Head Drive Belt is off the pulleys or broken. Reinstall or change Belt (refer to "Chapter 4: Maintaining the DR Stump Grinder"). ⇒ Confirm there is nothing wedged/ wrapped around cutter head, or Pulleys. ⇒ Confirm the throttle is moving on the engine. ⇒ Confirm that Belt has not stretched to a point that it is slipping off the Pulleys. ⇒ Clutch is not working. Change Clutch (refer to "Chapter 4: Maintaining the DR Stump Grinder").
<i>The Engine does not fully return to low idle when the throttle is released.</i>	<ul style="list-style-type: none"> ⇒ Throttle linkage is sticking. Adjust throttle linkage (refer to "Chapter 4: Maintaining the DR Stump Grinder")
<i>The Cutting Head is rotating but the cutting action is extremely slow and the stump is showing signs of excessive heat.</i>	<ul style="list-style-type: none"> ⇒ The teeth are dull or damaged. Replace Teeth (refer to "Chapter 4: Maintaining the DR Stump Grinder").
<i>Belt falls off Pulleys frequently.</i>	<ul style="list-style-type: none"> ⇒ Check Pulleys and Belt for damage. ⇒ Check tightness of Idler Arm Pivot Bolt.
<i>Left-side Wheel turns forward when Brake Lever is locked or machine is difficult to push when Brake Lever is released.</i>	<ul style="list-style-type: none"> ⇒ Brake Cable needs adjusting. Adjust Cable as needed (refer to "Chapter 4: Maintaining the DR Stump Grinder").

Chapter 6: Parts Lists and Schematic Diagrams

Parts List - HANDLEBAR ASSEMBLY

NOTE: Part numbers listed are available through DR Power Equipment.

<u>Ref#</u>	<u>Part#</u>	<u>Description</u>	<u>Ref#</u>	<u>Part#</u>	<u>Description</u>
01	27173	Cross Member, Handlebar, w/Labels	19	26479	Bracket, Brake Cable
02	13443	Bolt, 5/16-18 x 1-1/2"	20	17912	Bolt, Tri-Lobe, 1/4-20 x 1/2"
03	11076	Nut Nylon Lock 5/16-18	21	26476	Guard, Debris
04	26519	Label, Control Panel Front	22	11158	Bolt, HCS, 5/16-18 x 1", Gr 5, ZP
05	17929	Plug, Control Panel, With Cutout	23	11238	Washer, Flat, 1/4", USS
06	18069	Lever, Op Presence, w/ Wire	24	27172	Frame, w/Labels
07	16518	Lever, Brake, w/ Lock	25	26488	Label, Head Rotation
08	16495	Grip, Ergonomic, 1"	26	23494	Label, DR Logo, 6" Round
09	16496	Grip, 1"	27	23545	Label, CHP Address
10	26480	Throttle	28	26478	Cable, Brake
11	11163	Screw, #10 x 1-1/2", Type A	29	15345	Label, Throttle Control
12	26529	Handlebar, Right, w/Label	30	21720	Meter, Hour/RPM/Maintenance
13	15043	Bolt, Hhcs, 3/8-16 x 1-1/4", Gr5	31	26504	Switch, Start
14	11241	Washer, Flat, 5/16", USS	32	19320	Label, Start
15	24729	Handlebar, Left	33	23548	Keys
16	11075	Nut, Nylon Lock, 3/8-16	34	28701	Screw, M4 x 8mm
17	15712	Bolt, HCS, 3/8-16 x 2-1/4", Full Thread	35	28702	Washer, Lock, M4
18	11214	Cable Tie, 7 1/2"			

Schematic – HANDLEBAR ASSEMBLY

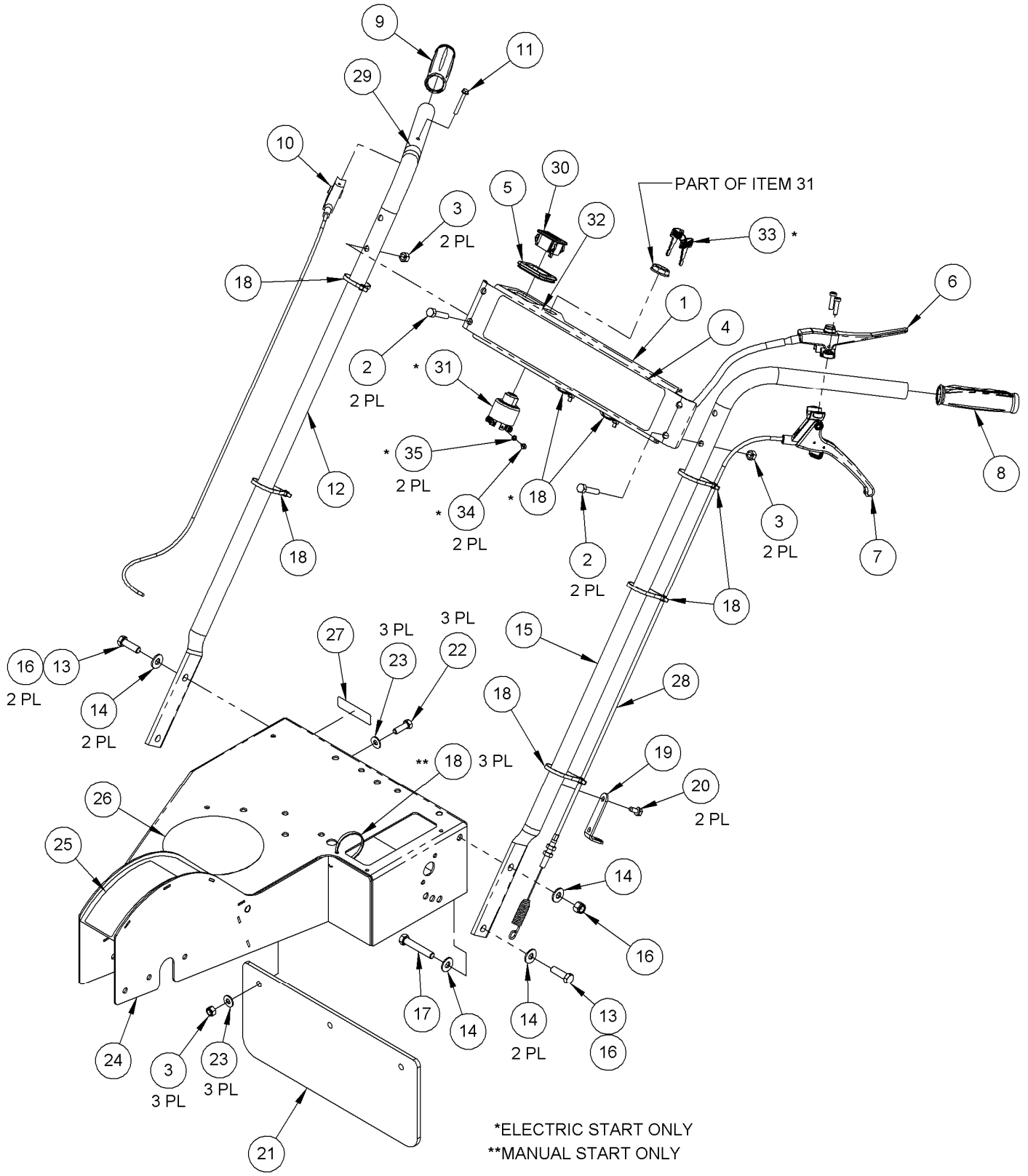

Parts List – DRIVE ASSEMBLY (see page 24 for 9HP specific parts list)

NOTE: Part numbers listed are available through DR Power Equipment.

Ref#	Part#	Description	Ref#	Part#	Description
01	26531	Engine, Subaru, 6HP, w/Labels	23	16480	Spring, Ext, 3/4" OD, .085 Wire, 3" L
02	13443	Bolt, 5/16-18 x 1-1/2"	24	13443	Bolt, 5/16-18 x 1-1/2"
03	11238	Washer, Flat 1/4", USS	25	11069	Nut, 5/16-18, ZP, Gr2
04	11076	Nut, Nylon Lock, 5/16-18	26	26472	Pulley, 4.5" Diam
05	26521	Clutch, Centrifugal, 3/4" Bore	27	25802	Bearing, Stamped Flange, 1" Bore
06	17882	Bolt, HCS, 5/16-24 x 1"	28	11158	Bolt, HCS, 5/16-18 x 1", Gr5, ZP
07	16514	Washer, .385" ID, 1.390" OD, 3/8" TH	29	26474	Guard, Pulley
08	26468	Belt, Stump Grinder, 6HP	30	26483	Ring, Retaining, 1" Shaft
09	26528	Guard, Belt, w/Labels	31	30409	Bolt, Pocket
10	12321	Bolt, HCS, 5/16-18 x 3/4"	32	30406	Tooth
11	11243	Washer, Lock, Split, 5/16"	33	30408	Pocket, Straight
12	25709	Label, Safety Icons	34	30407	Spacer, Tooth
13	19239	Label, DR Logo, 5-3/4" Silver	35	11076	Nut, Nylon Lock, 5/16-18, ZP
14	26566	Arm, Idler Pulley	36	29417	Cutter Head, Dual Straight Teeth
15	26535	Bolt, Shoulder, 1/2" x 3/4" Long	37	12781	Label, Warning, Check Oil
16	24677	Key, Square, 3/16" x 1", FBP	38	26485	Wire Harness
17	11241	Washer, Flat, 5/16", USS	39	142291	Key, Square, 1/4" x 1-1/4"
18	26482	Deflector, Exhaust			
19	18012	Pulley, Flat Idler, 3-1/4"			
20	12686	Bolt, HHCS, 3/8-16 x 2", Gr5		30505	Tooth Kit
21	16413	Nut, Nylon Lock, 3/8-16, Low Profile			
22	18887	Label, Hot Surface			

Not Illustrated

Schematic – DRIVE ASSEMBLY (see next page for 9HP specific parts)

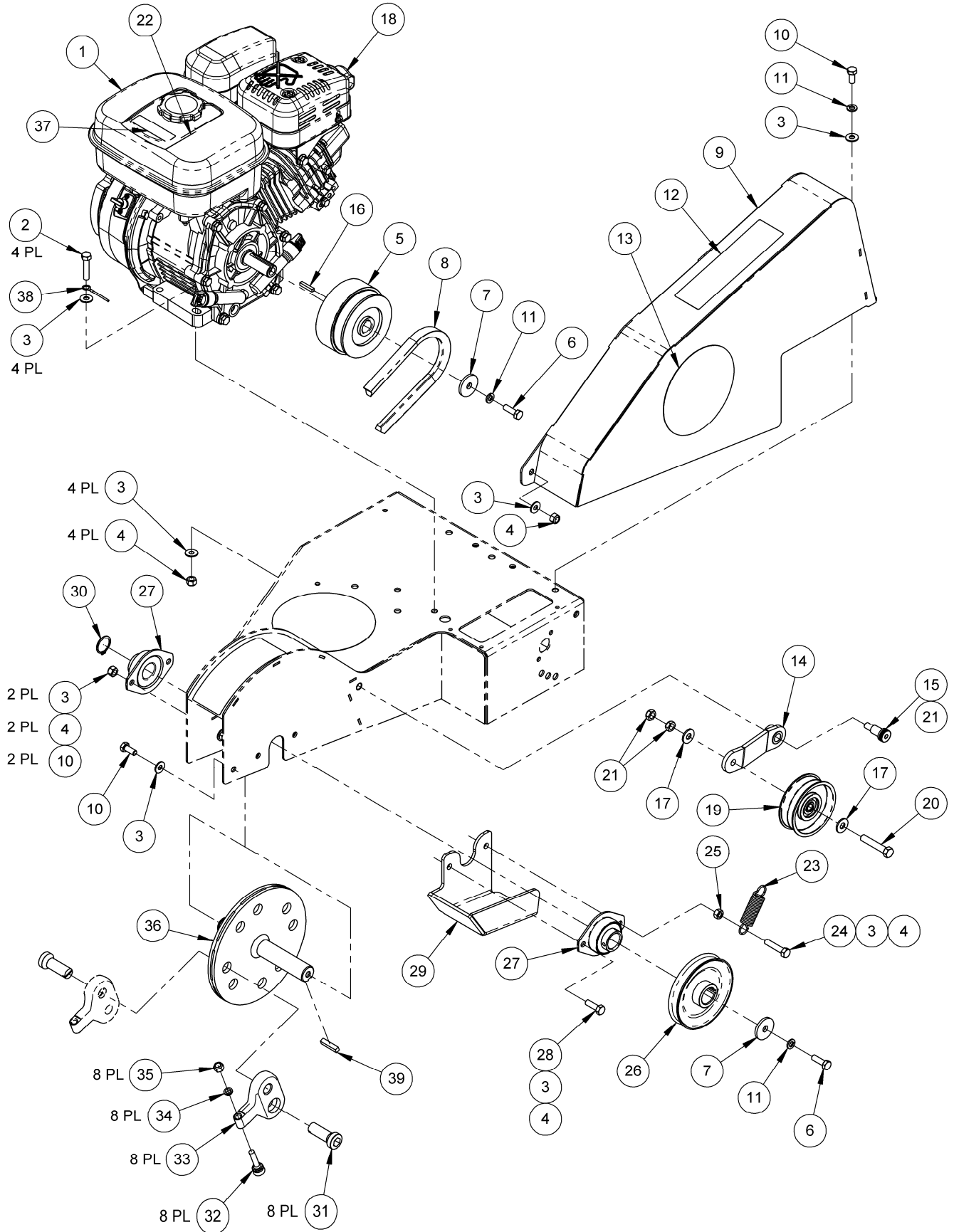

Parts List – DRIVE ASSEMBLY (9HP specific parts)

NOTE: Part numbers listed are available through DR Power Equipment.

Ref#	Part#	Description	Ref#	Part#	Description
01	27172	Frame, w/Labels	09	26533	Clutch, Centrifugal, 1" Bore
02	26536	Bolt, Serrated Flange, M6-1x16	10	26563	Belt, Stump Grinder 9HP
03	11241	Washer, Flat, 5/16", Uss	11	27140	Spacer, 1" ID, 1.375" OD, .313 Th
04	12334	Bolt, Hhcs, 3/8-16 x 1-3/4", Gr 5, Zp	12	27164	Washer, .47" Id, 1.4" Od, .15" Th
05	26485	Wire Harness, Manual Start	13	22911	Bolt, Hhcs, 7/16-20 X 1", Gr 8, Locking Patch
	28690	Wire Harness, Electric Start	14	11075	Nut Nylon Lock 3/8-16
06	12781	Label, Warning Add Oil	15	26568	Shim, 1" ID, 1.375" OD x .16 Th
07	28347	Engine w/Labels, Subaru, 9HP			
	28703	Engine W/ Label, 13.74 GTQ, Subaru E/S			
08	18887	Label, Hot Surface, R/C			

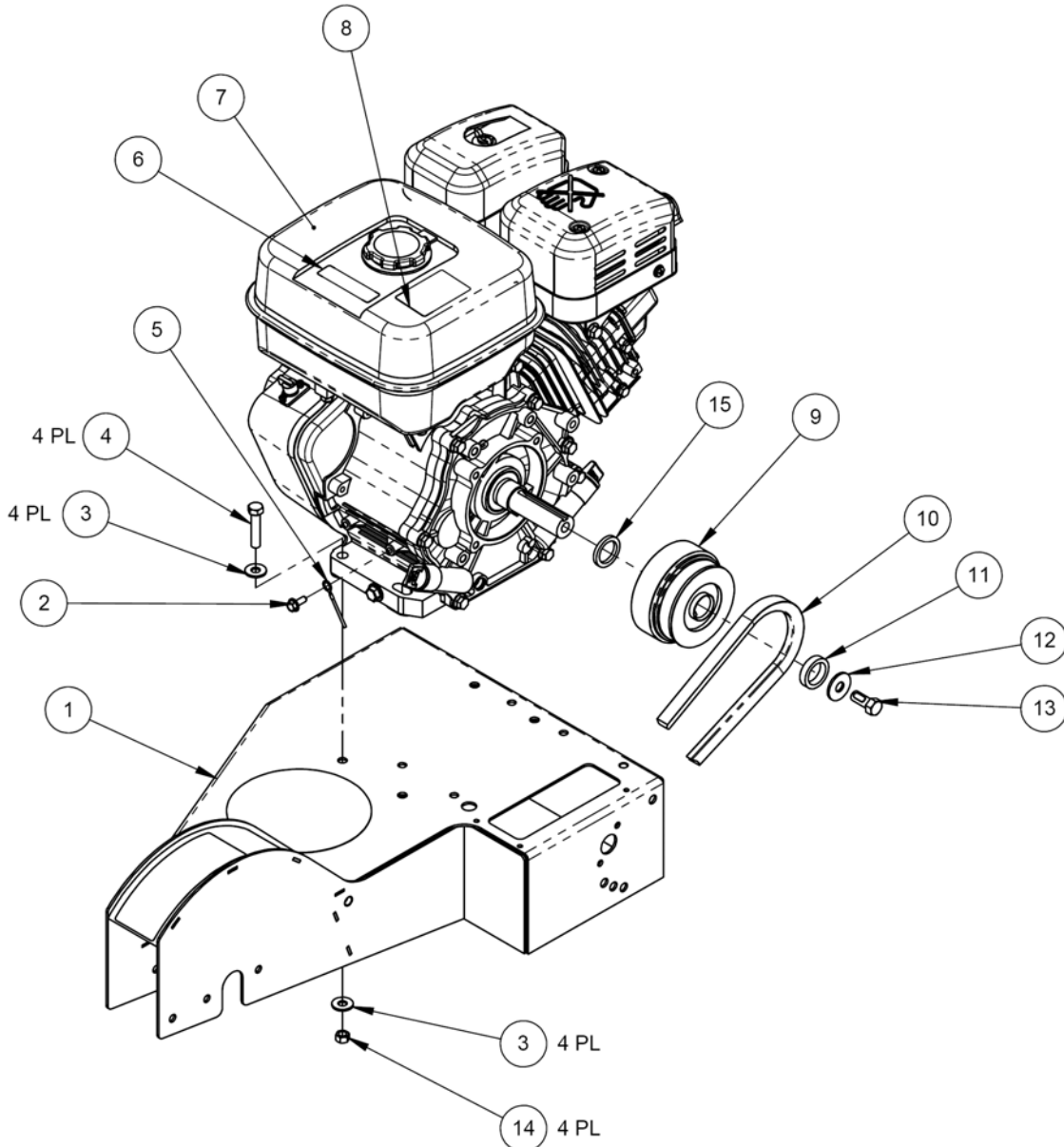

Parts List and Schematic – AXLE ASSEMBLY

NOTE: Part numbers listed are available through DR Power Equipment.

Ref#	Part#	Description	Ref#	Part#	Description
01	24744	Wheel, 14.5 x 7-6, 2 Ply, Gray	14	11076	Nut, Nylon Lock, 5/16-18
02	17882	Bolt, Hcs, 5/16-24 x 1"	15	11126	Ring, Retaining, 3/4", Ext
03	11243	Washer, Lock, Split, 5/16"	16	12969	Shim, 3/4" ID, 1-1/8" OD, 1/16" L, Zp
04	16514	Washer, .385 ID, 1.390 OD, 3/8" Th	17	26477	Bushing, Flange, 3/4" ID
05	26469	Bushing, Bronze, .75 OD, .63 ID	18	11073	Nut, Nylon Lock, 1/4-20
06	26564	Axle	19	11237	Washer, Flat, #10, Uss
07	24677	Key, Square, 3/16" x 1"	20	11983	Bolt, Hhcs, 1/4-20 x 3/4" L
08	26486	Brake Drum	21	24230	Hold Down, Battery
09	12321	Bolt, Hcs, 5/16-18 x 3/4"	22	13447	Battery, 9AH 12V
10	11238	Washer, Flat, 1/4", Uss	23	14386	Pad, Battery, 1.38" x 7.0"
11	26473	Brake, Band	24	28697	Pad, Battery, 2.5" x 6.125"
12	16413	Nut, Nylon Lock, 3/8-16, Lo Profile	25	25862	Bracket, Battery
13	12336	Bolt, Hhcs, 5/16-18 x 1-1/4", Gr5, Zp	26	28320	Clamp, Tube, 7/16", Vinyl coated

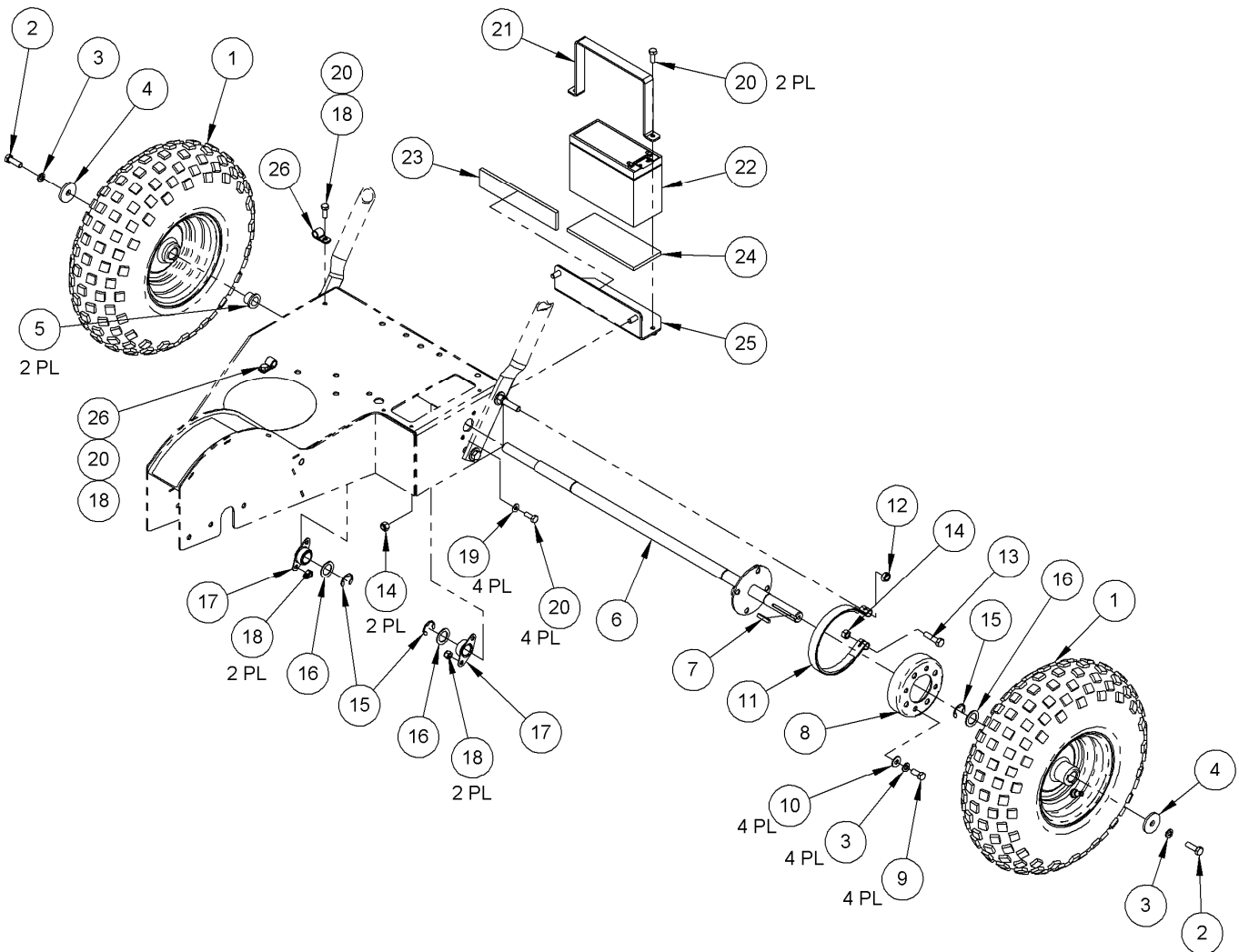

Notes:

Notes:

Daily Checklist for the DR STUMP GRINDER

To help maintain your DR STUMP GRINDER for optimum performance, we recommend you follow this checklist each time you use your Stump Grinder.

WARNING

Before performing any maintenance procedure or inspection, stop the engine, wait five (5) minutes to allow all parts to cool. Disconnect the spark plug wire, keeping it away from the spark plug.

- [] Check the engine oil and Gas Tank level.
- [] Check that Engine is clean of debris.
- [] Check the general condition of the Stump Grinder, e.g.; nuts, bolts, welds, etc.
- [] Check Belt for wear and/or stretching.
- [] Check Tire Pressure and wear.
- [] Check the Teeth for wear and damage.
- [] Check the Frame for wear and damage.
- [] Check the Debris Guard for wear and damage.
- [] Remove any debris wrapped around the Cutter Head for Bearing protection.

End of Season and Storage

WARNING

Before performing any maintenance procedure or inspection, stop the engine, wait five (5) minutes to allow all parts to cool. Disconnect the spark plug wire, keeping it away from the spark plug.

- Change the engine oil.
- Clean or replace the Air Filter.
- Check the teeth for wear and damage.
- Remove any debris wrapped around the Cutter Head
- If your DR STUMP GRINDER will be idle for more than 30 days, we recommend using a gas stabilizer. This will prevent sediment from gumming up the Carburetor. If there is dirt or moisture in the gas or tank, remove it by draining the tank. Completely fill the tank with fresh, unleaded gas and add the appropriate amount of stabilizer or gasoline additive. Run the Engine for a short time to allow the additive to circulate.
- Clean the exterior of the unit to remove all dirt, grease, and any other foreign material. To prevent rust, touch up painted surfaces that have been scratched or chipped.
- Be sure all nuts, bolts, and screws are securely fastened.
- Inspect moving parts and the Drive Belt for damage and wear; replace if necessary.
- Remove the Spark Plug(s) and pour about 1 ounce of motor oil into the Cylinder hole. Replace the Plug(s) and crank the Engine over a couple of times using the Pull Cord, or the Electric Starter (for Electric Start Machines). This will coat the piston and seat the valves to prevent moisture buildup.
- If possible, store the Stump Grinder in a dry, protected place. If it is necessary to store the Stump Grinder outside, cover it with a protective material (especially the Engine). For Electric Start Model, store the machine in a dry environment with temperatures between +40(degree symbol)F (5C) and +95F (+35C). Make sure the storage temperatures will never be outside of these limits. The lower the storage temperature is within the specified temperature, the better as the battery will discharge more slowly at low temperatures. If it is necessary to store the Stump Grinder outside make sure to disconnect the battery and store it in an environment as listed above. Make sure the disconnected battery terminals are not resting on any surface that may be prone to collecting water, snow or any other liquid as this may cause damage to the terminals and to the battery when reconnected.



75 MEIGS ROAD, P.O. BOX 25, VERGENNES, VERMONT 05491