

DR[®] WALK-BEHIND LEAF & LAWN VACUUM



SAFETY & OPERATING INSTRUCTIONS

Models: Manual-Start - Push
Manual-Start - Self-Propelled
Electric-Start - Self-Propelled



! WARNING!

READ AND UNDERSTAND THIS MANUAL AND ALL INSTRUCTIONS BEFORE OPERATING THIS VACUUM.

Congratulations on your purchase of a new DR WALK-BEHIND LEAF & LAWN VACUUM!

We have done our utmost to ensure that your DR WALK-BEHIND LEAF & LAWN VACUUM will be one of the most trouble-free and satisfying pieces of equipment you have ever owned. Please let us know of any questions or problems you may have. We want to answer or correct them as quickly as possible. When you do call, please have your order number, or serial number handy. **For technical assistance, please call Toll-Free 1-800-DR-OWNER (376-9637) and one of our Technical Support Representatives will be happy to help you.** We also hope to hear from you on how much you like your new helper.

In addition, please tell your friends about your new DR WALK-BEHIND LEAF & LAWN VACUUM! Having DR Owners spread the word about our products and our way of doing business is the best advertising we can have, and the best way to help us provide even better service in the years to come.

Thanks once again!



for all of us at
Country Home Products, Inc.

SALES MANAGER

COPYRIGHT

©2007 Country Home Products, Inc. All rights reserved.



DR® Power Equipment
A division of Country Home Products®
127 Meigs Road
Vergennes, VT 05491

Toll-Free phone: 1-800-DR-OWNER (376-9637)

Fax: 1-802-877-1213

Web site: www.dr-owner.com

Table of Contents

CHAPTER 1.....	1
INTRODUCING THE DR WALK-BEHIND LEAF & LAWN VACUUM	1
Conventions used in this manual	1
WLL Specification Sheet.....	2
CHAPTER 2.....	3
GENERAL SAFETY RULES.....	3
Labels	3
Protecting Yourself and Those Around You	5
Slope Operation.....	6
Safety for Children	6
Safety with Gasoline-Powered Machines.....	7
General Safety.....	8
A Note to All Users	9
Additional Information and Potential Changes.....	9
CHAPTER 3.....	11
SETTING UP YOUR DR WALK-BEHIND LEAF & LAWN VACUUM.....	11
DR WALK-BEHIND LEAF & LAWN VACUUM Controls and Features.....	12
Unpacking the Machine	13
Opening the Shipping Carton	13
Connecting the Battery Wire (Electric-Starting Model).....	14
Adding the Engine Oil and Gasoline.....	15
CHAPTER 4.....	17
OPERATING YOUR DR WALK-BEHIND LEAF & LAWN VACUUM	17
Operator Controls.....	17
Before Starting the Engine.....	18
Manual-Starting	18
Electric Starting.....	19
Stopping the Engine	19
Operating Safety	20
Vacuum Nozzle Height Adjustment.....	20
Vacuum Nozzle Door Operation	21
Vacuuming Operation	22
Slopes and Uneven Terrain	23
Clearing a Clogged Nozzle	23
Emptying the Debris Bag.....	24
Attaching the Debris Bag.....	25
Installing the Optional Disposable Debris Bag Liner (P/N 21794, package of 12)	26
Handling and Transporting.....	27
CHAPTER 5.....	29
MAINTAINING THE DR WALK-BEHIND LEAF & LAWN VACUUM	29
Regular Maintenance Checklist.....	29
Lubrication	30
Removing and Replacing the Engine Oil	31
Battery Care (For Electric-Starting Models).....	32
Charging the Battery.....	32
Removing and Replacing the Impeller.....	33
Drive Clutch Cable Adjustment.....	35
Removing and Replacing the Drive Belt	36
Drive Chain Replacement, Alignment and Tension	37

Throttle Cable Adjustment	39
Disposing of the Battery Responsibly (Electric-Start Models)	40
Recycling a Used Battery	40
End of Season and Storage	41
 CHAPTER 6.....	 43
TROUBLESHOOTING.....	43
Troubleshooting Table.....	43
 CHAPTER 7.....	 46
PARTS LISTS, SCHEMATIC DIAGRAMS AND WARRANTY.....	46
Parts List - Nozzle and Front Axle Assembly.....	46
Schematic Diagram - Nozzle and Front Axle Assembly.....	47
Parts List - Drive/Rear Axle Assembly.....	48
Schematic Diagram - Drive/Rear Axle Assembly.....	49
Parts List - Engine w/Impeller and Housing - Manual-Start Model	50
Schematic Diagram - Engine w/Impeller and Housing - Manual-Start Model	51
Parts List - Engine w/Impeller and Housing - Electric-Start Model.....	52
Schematic Diagram - Engine w/Impeller and Housing - Electric-Start Model.....	53
Parts List - Top Shield, Bag Assembly and Controls - All Models	54
Schematic Diagram - Top Shield, Bag Assembly and Controls - All Models	55
Warranty.....	57

INTRODUCING THE DR WALK-BEHIND LEAF & LAWN VACUUM

This manual will help you set up and safely operate your new DR WALK-BEHIND LEAF & LAWN VACUUM. Careful adherence to the safety and operating instructions in this manual will ensure many years of productive use.

Please let us know of any questions you may have. We want to answer them as quickly as possible. When you do call, please have your order number, or serial number handy. **For technical assistance, please call Toll-Free 1-800-DR-OWNER (376-9637) and one of our Technical Support Representatives will be happy to help you.**

Conventions used in this manual

WARNING!

THIS INDICATES A HAZARDOUS SITUATION, WHICH, IF NOT AVOIDED, COULD RESULT IN DEATH OR SERIOUS INJURY.

CAUTION!

THIS INDICATES A HAZARDOUS SITUATION, WHICH, IF NOT AVOIDED, COULD RESULT IN MINOR OR MODERATE INJURY.

NOTICE!

THIS INFORMATION IS IMPORTANT IN THE PROPER USE OF YOUR MACHINE. FAILURE TO FOLLOW THIS INSTRUCTION COULD RESULT IN DAMAGE TO YOUR MACHINE OR PROPERTY.

Tip: This is a helpful hint to guide you in getting the most out of your DR WALK-BEHIND LEAF & LAWN VACUUM.

Tools Needed: This indicates you will need a special tool to perform a maintenance function on your Vacuum.

NOTE: *This information may be helpful to you.*

If you are ever unsure about an action you are about to take, don't do it, contact Country Home Products' Toll-Free support at 1-800-DR-OWNER (376-9637) for help or information.

WLL Specification Sheet

	WLL 6.5 TQ Manual-Start, Push	WLL 6.5 TQ Manual-Start, Self-Propelled	WLL 6.5 TQ Electric-Start, Self-Propelled
Engine	Manual, Briggs & Stratton	Manual, Briggs & Stratton	Electric, Briggs & Stratton
Type	Quantum	Quantum	Quantum
Torque	6.5 ft-lbs	6.5 ft-lbs	6.5 ft-lbs
Self Propelled	No	Yes	Yes
Battery	No	No	12V 5.6ah
Impeller weight	17.56 lbs	17.28 lbs	17.28 lbs
Impeller MPH	123	123	123
RPM's			
CFM	3250	3250	3250
Rear wheels	14" Resin, smooth	14" Resin, treaded	14" Resin, treaded
Front wheels	14" Resin, smooth	14" Resin, smooth	14" Resin, smooth
Height Adjustment	Single Hand Crank	Single Hand Crank	Single Hand Crank
Range	0" - 9"	0" - 9"	0" - 9"
Nozzle size	Intake opening: 26" Outside (with door): 28"	Intake opening: 26" Outside (with door): 28"	Intake opening: 26" Outside (with door): 28"
Nozzle Material	LLDPE (Low Linear Density Polyethelyne)	LLDPE (Low Linear Density Polyethelyne)	LLDPE (Low Linear Density Polyethelyne)
Forward speeds	None	3	3
Rate - 1st		1.2 MPH	1.2 MPH
2nd		1.7 MPH	1.7 MPH
3rd		2.2 MPH	2.2 MPH
Bagger volume	3.75 Bushels- 30 Gallons aprox. 40-80 lbs.	3.75 Bushels- 30 Gallons aprox. 40-80 lbs.	3.75 Bushels- 30 Gallons aprox. 40-80 lbs.
Reduction	4:1	4:1	4:1
Length	62.5"	62.5"	62.5"
Height	45.5"	45.5"	45.5"
Width	28"	28"	28"
Fuel Capacity	1.6 Qt.	1.6 Qt.	1.6 Qt.
Oil Capacity	0.63 Qt.or 20 oz	0.63 Qt.or 20 oz	0.63 Qt.or 20 oz
Product weight	158 lbs.	181 lbs.	188 lbs.
Shipping weight	181 lbs.	204 lbs.	211 lbs.
Shipping Box Dimension	73" L x 31" W x 37" H	73" L x 31" W x 37" H	73" L x 31" W x 37" H

GENERAL SAFETY RULES

WARNING!

READ THIS *SAFETY & OPERATING* MANUAL BEFORE YOU USE THE DR WALK-BEHIND LEAF & LAWN VACUUM. BECOME FAMILIAR WITH THE SERVICE RECOMMENDATIONS TO ENSURE THE BEST PERFORMANCE FROM YOUR VACUUM.

Labels

Your DR WALK-BEHIND LEAF & LAWN VACUUM carries prominent labels as reminders for its proper and safe use. Shown below are copies of all the labels that appear on the equipment. Take a moment to study them and make a note of their location on your DR WALK-BEHIND LEAF & LAWN VACUUM as you assemble and *before* you operate the machine. Replace damaged or missing safety and information labels immediately.



Read the instruction manual thoroughly before using this machine. #21860

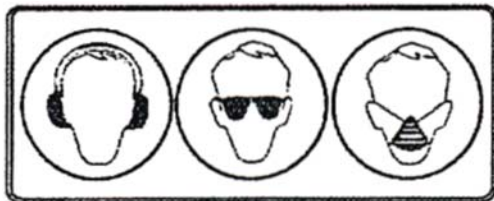

Use approved eye and hearing protection when operating this machine. In dusty conditions, we recommend wearing a particle mask. #21856

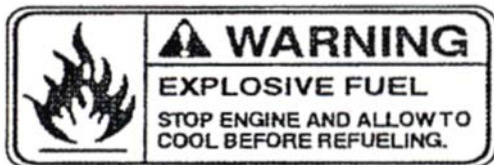

Always stop the engine and allow five (5) minutes to cool before refueling. #21858



NEVER place your hands or feet near moving or rotating parts. #21855



Do not allow people or pets near the machine when it is operating. #21854



Keep hands away from Drive Belt and Sprocket when the engine is running. #21862

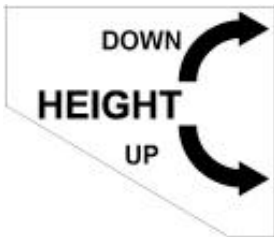

To raise or lower the vacuum nozzle, turn the crank handle clockwise or counterclockwise. #21675

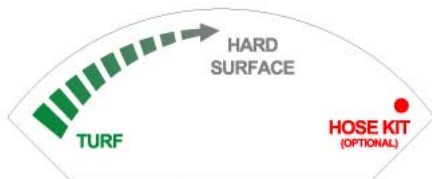

You can adjust the Nozzle Door for Turf, a Hard Surface, or the Optional Hose Kit. #21859

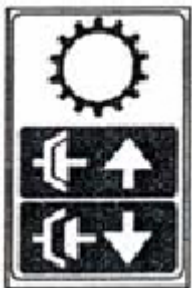

To engage the Drive, squeeze the Clutch Drive Lever against the Handlebar. #21853

Protecting Yourself and Those Around You

WARNING!

THIS IS A HIGH-POWERED MACHINE, WITH MOVING PARTS OPERATING WITH HIGH ENERGY AT HIGH SPEEDS. USE PROPER CLOTHING AND SAFETY GEAR WHEN OPERATING THIS MACHINE TO PREVENT OR MINIMIZE THE RISK OF SEVERE INJURY. YOU MUST OPERATE THE MACHINE SAFELY. UNSAFE OPERATION CAN CREATE A NUMBER OF HAZARDS FOR YOU, AS WELL AS ANYONE ELSE IN THE NEARBY AREA. ALWAYS TAKE THE FOLLOWING PRECAUTIONS WHEN OPERATING THIS MACHINE:

- ALWAYS WEAR PROTECTIVE GOGGLES OR SAFETY GLASSES WITH SIDE SHIELDS WHILE OPERATING THIS VACUUM SYSTEM TO PROTECT YOUR EYES FROM POSSIBLE FOREIGN OBJECTS THROWN FROM THE MACHINE.
- WEAR SHOES WITH NON-SLIP TREADS WHEN USING YOUR DR WALK-BEHIND LEAF & LAWN VACUUM. IF YOU HAVE SAFETY SHOES, WE RECOMMEND WEARING THEM. DO NOT USE THE MACHINE WHILE BAREFOOT OR WEARING OPEN SANDALS.
- AVOID WEARING LOOSE CLOTHING OR JEWELRY, WHICH CAN CATCH ON THE MACHINE'S MOVING PARTS.
- WE RECOMMEND WEARING GLOVES WHILE USING YOUR DR WALK-BEHIND LEAF & LAWN VACUUM. BE SURE YOUR GLOVES FIT PROPERLY AND DO NOT HAVE LOOSE CUFFS OR DRAWSTRINGS.
- ALWAYS WEAR GLOVES WHEN EMPTYING THE DEBRIS BAG.
- AFTER VACUUMING GLASS, BOTTLES OR CANS, DISPOSE OF THIS WASTE PROPERLY, NEVER IN A COMPOST PILE.
- WE RECOMMEND CHANGING BOTH THE OPTIONAL DISPOSABLE DEBRIS BAG LINER AND THE OUTER DEBRIS BAG AFTER VACUUMING GLASS AND OTHER DEBRIS AND BEFORE USING THE SYSTEM TO VACUUM MATERIAL THAT MAY BE USED FOR COMPOST OR MULCH.
- WEAR LONG PANTS WHILE OPERATING THE MACHINE.
- USE EAR PROTECTORS OR EAR PLUGS RATED FOR AT LEAST 20 DBA TO PROTECT YOUR HEARING.
- NEVER ALLOW PEOPLE WHO ARE UNFAMILIAR WITH THESE INSTRUCTIONS TO USE THE VACUUM. ALLOW ONLY RESPONSIBLE INDIVIDUALS WHO ARE FAMILIAR WITH THESE RULES OF SAFE OPERATION TO USE YOUR MACHINE.
- NEVER PLACE YOUR HANDS, FEET, OR ANY PART OF YOUR BODY NEAR OR UNDER ANY MOVING PART WHILE THE MACHINE IS RUNNING.
- KEEP BYSTANDERS AWAY FROM YOUR WORK AREA AT ALL TIMES. TO BE SAFE, DO NOT OPERATE THE MACHINE NEAR SMALL CHILDREN OR PETS, AND NEVER ALLOW CHILDREN TO OPERATE THE VACUUM. STOP THE ENGINE WHEN ANOTHER PERSON OR PET APPROACHES.
- NEVER USE THE MACHINE WITH THE DEBRIS BAG REMOVED.
- NEVER OPERATE THE ENGINE WITH THE AIR CLEANER OR COVER OVER THE CARBURETOR AIR-INTAKE REMOVED, EXCEPT FOR ADJUSTMENT. REMOVAL OF SUCH PARTS COULD CREATE A FIRE HAZARD. DO NOT USE FLAMMABLE SOLUTIONS TO CLEAN AIR FILTER.
- THE MUFFLER AND ENGINE BECOME VERY HOT AND CAN CAUSE A SEVERE BURN; DO NOT TOUCH.
- CLEAR THE WORK AREA OF OBJECTS SUCH AS ROCK, STRING-LIKE MATERIAL, WIRE, ROPE, OR RAGS. INGESTING THESE OBJECTS INTO THE VACUUM COULD DAMAGE THE MACHINE AND/OR CAUSE INJURY.
- NEVER, UNDER ANY CONDITIONS, REMOVE, BEND, CUT, FIT, WELD, OR OTHERWISE ALTER STANDARD PARTS ON THE DR WALK-BEHIND LEAF & LAWN VACUUM. THIS INCLUDES ALL SHIELDS AND GUARDS. MODIFICATIONS TO YOUR MACHINE COULD CAUSE PERSONAL INJURIES AND PROPERTY DAMAGE AND WILL VOID YOUR WARRANTY.

Slope Operation

WARNING!

SLOPES ARE A MAJOR FACTOR RELATED TO SLIP AND FALL ACCIDENTS, WHICH CAN RESULT IN SEVERE INJURY. ALL SLOPES REQUIRE CAUTION. IF YOU FEEL UNEASY ON A SLOPE, DO NOT VACUUM IT. ALWAYS TAKE THE FOLLOWING PRECAUTIONS WHEN USING THIS MACHINE ON SLOPES:

ALWAYS:

- VACUUM ACROSS THE FACE OF SLOPES; NEVER UP AND DOWN. EXERCISE EXTREME CAUTION WHEN CHANGING DIRECTION ON SLOPES.
- REMOVE OBJECTS SUCH AS STONES, WIRE, ROPE, OR RAGS.
- WATCH FOR HOLES, RUTS, OR BUMPS IN THE LANDSCAPE.

NEVERS:

- NEVER VACUUM NEAR DROP-OFFS, DITCHES, OR EMBANKMENTS; YOU COULD LOSE YOUR FOOTING OR BALANCE.
 - NEVER VACUUM ON SLOPES GREATER THAN 20 DEGREES, OR ANY EXCESSIVELY STEEP SLOPES.
 - NEVER VACUUM ON WET, OR SLIPPERY SLOPES; REDUCED TRACTION COULD RESULT IN SLIPPING.
 - NEVER PARK THE VACUUM ON A STEEP GRADE OR SLOPE.
-

Safety for Children

WARNING!

TRAGIC ACCIDENTS CAN OCCUR IF THE OPERATOR IS NOT ALERT TO THE PRESENCE OF CHILDREN. CHILDREN ARE OFTEN ATTRACTED TO THE MACHINE AND THE VACUUMING ACTIVITY. NEVER ASSUME THAT CHILDREN WILL REMAIN WHERE YOU LAST SAW THEM.

- KEEP CHILDREN OUT OF THE WORK AREA AND UNDER THE WATCHFUL CARE OF A RESPONSIBLE ADULT.
 - BE ALERT AND ALWAYS TURN OFF THE DR WALK-BEHIND LEAF & LAWN VACUUM ENGINE IF CHILDREN ENTER THE WORK AREA.
 - BEFORE, AND WHILE MOVING BACKWARDS, LOOK BEHIND, AND DOWN FOR SMALL CHILDREN.
 - NEVER ALLOW CHILDREN TO OPERATE THE VACUUM.
 - USE EXTRA CARE WHEN APPROACHING BLIND CORNERS, SHRUBS, TREES, OR OTHER OBJECTS THAT MAY OBSCURE YOUR VISION.
-

Safety with Gasoline-Powered Machines

WARNING!

GASOLINE IS A HIGHLY FLAMMABLE LIQUID. GASOLINE ALSO GIVES OFF FLAMMABLE VAPOR THAT CAN BE EASILY IGNITED AND CAUSE A FIRE OR EXPLOSION. NEVER OVERLOOK THE HAZARDS OF GASOLINE. ALWAYS FOLLOW THESE PRECAUTIONS:

- **NEVER RUN THE ENGINE IN AN ENCLOSED AREA OR WITHOUT PROPER VENTILATION AS THE EXHAUST FROM THE ENGINE CONTAINS CARBON MONOXIDE, WHICH IS AN ODORLESS, TASTELESS, AND DEADLY POISONOUS GAS.**
- **STORE ALL FUEL AND OIL IN CONTAINERS SPECIFICALLY DESIGNED AND APPROVED FOR THIS PURPOSE AND KEEP AWAY FROM HEAT AND OPEN FLAME, AND OUT OF THE REACH OF CHILDREN.**
- **FILL THE GASOLINE TANK OUTDOORS WITH THE ENGINE OFF AND ALLOW THE ENGINE TO COOL COMPLETELY. DO NOT HANDLE GASOLINE IF YOU OR ANYONE NEARBY IS SMOKING, OR IF YOU ARE NEAR ANYTHING THAT COULD CAUSE IT TO IGNITE OR EXPLODE. REPLACE THE FUEL TANK AND FUEL CONTAINER CAPS SECURELY.**
- **IF YOU SPILL GASOLINE, DO NOT ATTEMPT TO START THE ENGINE. MOVE THE MACHINE AWAY FROM THE AREA OF THE SPILL AND AVOID CREATING ANY SOURCE OF IGNITION UNTIL THE GAS VAPORS HAVE DISSIPATED. WIPE UP ANY SPILLED FUEL TO PREVENT A FIRE HAZARD AND PROPERLY DISPOSE OF THE WASTE.**
- **ALLOW THE ENGINE TO COOL COMPLETELY AND EMPTY THE DEBRIS BAG BEFORE STORING THE DR WALK-BEHIND LEAF & LAWN VACUUM IN ANY ENCLOSURE. REMEMBER, DECOMPOSING MATERIAL GENERATED HEAT AND START A FIRE. NEVER STORE THE MACHINE WITH GAS IN THE TANK OR A FUEL CONTAINER, NEAR AN OPEN FLAME OR SPARK SUCH AS A WATER HEATER.**
- **NEVER MAKE ADJUSTMENTS OR REPAIRS WITH THE ENGINE RUNNING. DISCONNECT THE SPARK PLUG WIRE AND KEEP THE WIRE AWAY FROM THE SPARK PLUG TO PREVENT ACCIDENTAL STARTING.**
- **NEVER CHECK FOR AN IGNITION SPARK WITH THE SPARK PLUG OR SPARK PLUG WIRE REMOVED. USE AN APPROVED SPARK TESTER.**
- **NEVER TAMPER WITH SAFETY DEVICES. CHECK THEIR PROPER OPERATION REGULARLY.**
- **NEVER CHANGE THE ENGINE GOVERNOR SETTINGS OR MODIFY THE ENGINE SPEED. MODIFICATIONS WILL VOID YOUR WARRANTY.**
- **TO REDUCE FIRE HAZARD, KEEP THE ENGINE AND MUFFLER AREA FREE OF DEBRIS BUILD-UP SUCH AS LEAVES, GRASS, OIL, GREASE, OR ANY OTHER COMBUSTIBLE MATERIAL. CLEAN THE ENGINE AREA AFTER EACH USE.**
- **NEVER OPERATE THE ENGINE WITHOUT THE MUFFLER. INSPECT THE MUFFLER PERIODICALLY AND REPLACE IF NECESSARY. IF EQUIPPED WITH A MUFFLER DEFLECTOR, INSPECT THE DEFLECTOR PERIODICALLY AND REPLACE IF NECESSARY.**
- **NEVER OPERATE THE ENGINE WITH THE AIR CLEANER OR THE COVER OVER THE CARBURETOR AIR-INTAKE REMOVED, EXCEPT FOR ADJUSTMENT. REMOVAL OF SUCH PARTS COULD CREATE A FIRE HAZARD.**
- **ALWAYS CHECK FUEL LINES AND FITTINGS FREQUENTLY FOR CRACKS OR LEAKS, REPLACE IF NECESSARY.**

WARNING!

OPERATING THIS VACUUM SAFELY IS NECESSARY TO PREVENT OR MINIMIZE THE RISK OF DEATH OR SERIOUS INJURY. UNSAFE OPERATION CAN CREATE A NUMBER OF HAZARDS FOR YOU. ALWAYS TAKE THE FOLLOWING PRECAUTIONS WHEN OPERATING THIS VACUUM:

- KEEP IN MIND THAT THE OPERATOR OR USER IS RESPONSIBLE FOR ACCIDENTS OR HAZARDS OCCURRING TO OTHER PEOPLE, THEIR PROPERTY, AND THEMSELVES.
- YOUR DR WALK-BEHIND LEAF & LAWN VACUUM IS A POWERFUL TOOL, NOT A PLAYTHING. EXERCISE EXTREME CAUTION AT ALL TIMES. THE DESIGN OF THIS MACHINE IS TO VACUUM DEBRIS. DO NOT USE IT FOR ANY OTHER PURPOSE.
- KNOW HOW TO STOP THE VACUUM QUICKLY; SEE PAGE 25.
- NEVER ALLOW PEOPLE OR PETS TO RIDE ON THE DR WALK-BEHIND LEAF & LAWN VACUUM.
- NEVER START THE ENGINE WITHOUT THE DEBRIS BAG ATTACHED FIRMLY TO THE TOP SHIELD ASSEMBLY. SEE *FIGURE 14* ON PAGE 18.
- NEVER ATTEMPT TO REMOVE THE DEBRIS BAG WHILE THE DR WALK-BEHIND LEAF & LAWN VACUUM ENGINE IS RUNNING. DEBRIS MAY EXIT AT HIGH VELOCITY OUT OF THE OPENINGS CREATED IN THE SEAMS AS YOU UNLATCH THE DEBRIS BAG.
- EMPTY THE DEBRIS BAG AFTER EACH USE TO PREVENT SPONTANEOUS COMBUSTION DUE TO DECAYING MATERIAL.
- DO NOT VACUUM IN SANDY AREAS WHERE YOU WILL VACUUM LARGE QUANTITIES OF SAND.
- NEVER OPERATE THE VACUUM NEAR HOT OR BURNING DEBRIS OR ANY TOXIC OR EXPLOSIVE MATERIALS.
- IF THE MACHINE SHOULD START MAKING AN UNUSUAL NOISE OR VIBRATION, STOP THE ENGINE AND WAIT FIVE (5) MINUTES TO COOL. VIBRATION IS GENERALLY A WARNING OF TROUBLE. DISCONNECT THE SPARK PLUG WIRE AND INSPECT FOR CLOGGING, DAMAGED, OR WORN IMPELLER, LOOSE IMPELLER BOLT, LOOSE IMPELLER KEY, OR LOOSE ENGINE MOUNTING BOLTS. CLEAN AND REPAIR AND/OR REPLACE DAMAGED PARTS.
- ALWAYS SHUT OFF THE DR WALK-BEHIND LEAF & LAWN VACUUM ENGINE, WAIT FIVE (5) MINUTES TO COOL, AND DISCONNECT THE SPARK PLUG WIRE BEFORE ATTEMPTING TO CLEAR ANY OBSTRUCTIONS.
- ALWAYS KEEP THE EQUIPMENT IN A GOOD SAFE OPERATING CONDITION. ALWAYS MAKE CERTAIN NUTS AND BOLTS ARE TIGHT AND ALWAYS USE THE SUPPLIED SELF-LOCKING HARDWARE; DO NOT SUBSTITUTE.
- USE THE DR WALK-BEHIND LEAF & LAWN VACUUM ONLY IN DAYLIGHT.
- WHILE USING THE VACUUM, DO NOT HURRY OR TAKE THINGS FOR GRANTED. WHEN IN DOUBT ABOUT THE EQUIPMENT OR YOUR SURROUNDINGS, STOP THE MACHINE AND TAKE THE TIME TO LOOK THINGS OVER.
- NEVER LEAVE THE MACHINE UNATTENDED WITH THE ENGINE RUNNING.
- DO NOT OPERATE THE MACHINE WHEN UNDER THE INFLUENCE OF ALCOHOL, DRUGS, OR MEDICATION.
- SEE MANUFACTURER'S INSTRUCTIONS FOR PROPER OPERATION AND INSTALLATION OF ACCESSORIES. ONLY USE ACCESSORIES APPROVED BY COUNTRY HOME PRODUCTS, INC.
- NO LIST OF WARNINGS AND CAUTIONS CAN BE ALL-INCLUSIVE. IF SITUATIONS OCCUR THAT ARE NOT COVERED BY THIS MANUAL, THE OPERATOR MUST APPLY COMMON SENSE AND OPERATE THIS VACUUM IN A SAFE MANNER. CALL 1-800-DR-OWNER (376-9637) FOR ASSISTANCE.

A Note to All Users

Under California law, and the laws of some other states, you are not permitted to operate an internal combustion engine using hydrocarbon fuels without an engine spark arrester. This also applies to operation on US Forest Lands. All DR WALK-BEHIND LEAF & LAWN VACUUMS shipped to California and Washington State are provided with spark arresters. Failure of the owner/operator to maintain this equipment in compliance with state regulations is a misdemeanor under California law and may be in violation of other state and/or federal regulations. Contact your local fire marshal or forest service for specific information in your area.

Additional Information and Potential Changes

Country Home Products, Inc. reserves the right to discontinue, change, and improve its products at any time without notice or obligation to the purchaser. The descriptions and specifications contained in this manual were in effect at printing. Equipment described within this manual may be optional. Some illustrations may not be applicable to your machine.

SETTING UP YOUR DR WALK-BEHIND LEAF & LAWN VACUUM

This chapter outlines a few simple steps you will need to follow to set up your new machine before you use it. It may be helpful to familiarize yourself with the controls and features on your new machine by reviewing the picture in the next section before beginning the steps outlined in this chapter. **If you have any questions at all, please feel free to contact our Technical Support Representatives at our Toll-Free number: 1-800-DR-OWNER (376-9637).**

DR WALK-BEHIND LEAF & LAWN VACUUM Controls and Features

NOTE: The model shown in Figure 1 may look slightly different from your machine.

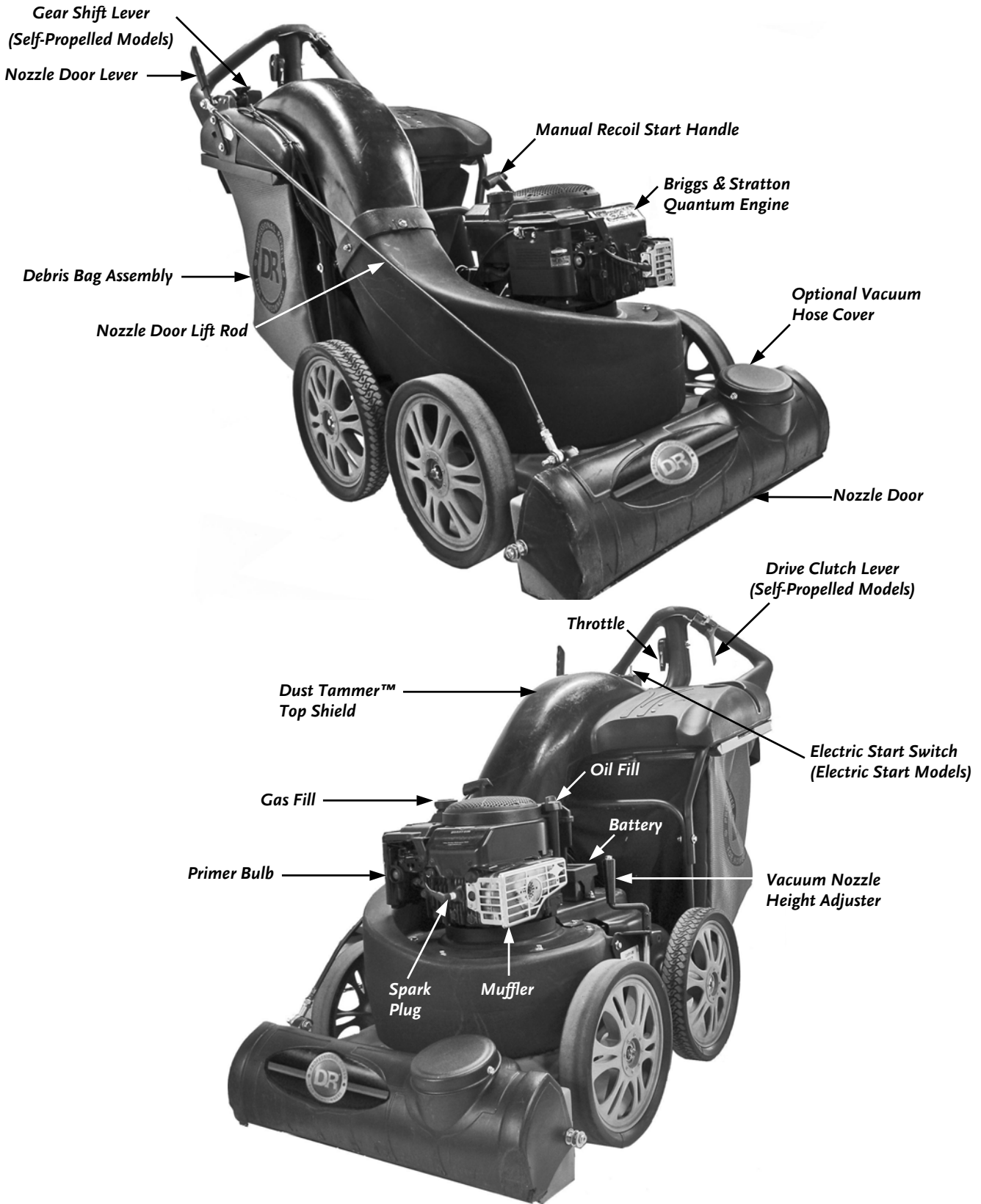

Unpacking the Machine

Your DR WALK-BEHIND LEAF & LAWN VACUUM shipped in one carton, completely assembled.

Items Supplied in Shipping Carton:

- DR WALK-BEHIND LEAF & LAWN VACUUM
- *Safety & Operating Instructions* Manual
- Briggs and Stratton Engine Manual

Opening the Shipping Carton

Tool Needed:

- Pliers
- Box Cutter



CAUTION!

STABILIZE THE SHIPPING CONTAINER ON A FLAT SURFACE BEFORE ATTEMPTING TO UNPACK THE MACHINE.

1. Using Pliers, carefully remove the staples from the top of the shipping carton and open the top (**Figure 2**). Be careful of the staples; they are sharp.
2. Remove the Protective Packing Material (**Figure 2**).
3. Remove any accessories and the corrugated divider from the center of the carton (**Figure 3**).
4. Cut the cardboard top to bottom in the seams at the front of the carton and fold it down (**Figure 4**).
5. Grasp the Control Handle and roll the machine from the shipping carton (**Figure 5**).
6. Do not discard your packaging material until you are fully satisfied with your new DR WALK-BEHIND LEAF & LAWN VACUUM.

Protective
Packing
Material

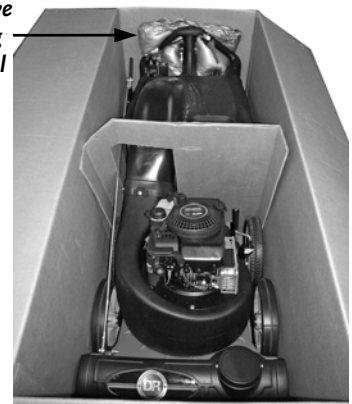

Figure 2

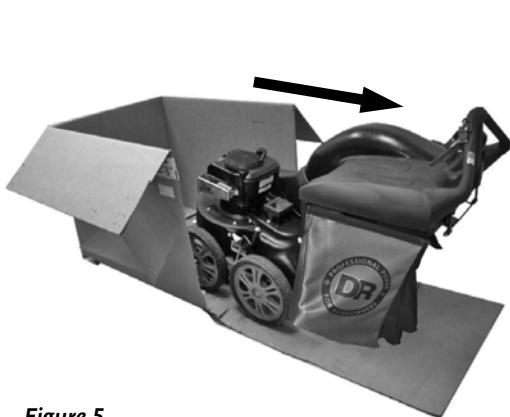

Figure 5



Figure 4

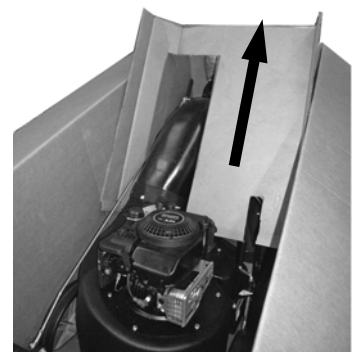

Figure 3

Connecting the Battery Wire (Electric-Starting Model)

We ship all electric-starting systems with the negative terminal battery wire disconnected. This prevents the battery from discharging during shipment. Before using your DR WALK-BEHIND LEAF & LAWN VACUUM, you must connect the battery wire.

Connect the negative wire to the negative terminal on the battery (**Figure 6**).

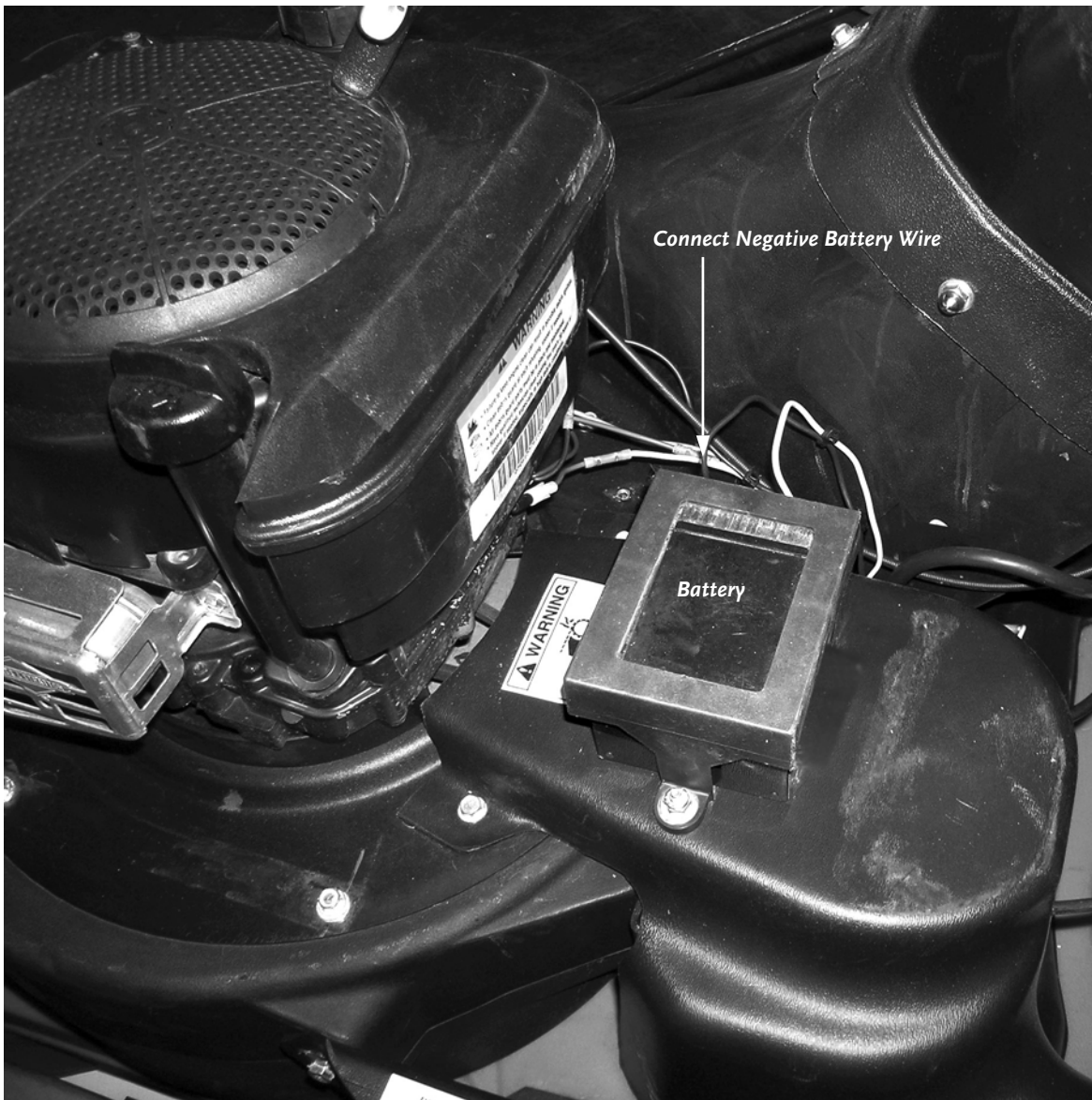

Figure 6

Adding the Engine Oil and Gasoline

NOTICE!

- YOU MUST ADD OIL BEFORE STARTING THE ENGINE. THIS MACHINE SHIPPED WITHOUT OIL. TRACES OF OIL MAY BE IN THE RESERVOIR FROM FACTORY TESTING, BUT YOU MUST ADD OIL BEFORE STARTING THE ENGINE. FILL THE RESERVOIR SLOWLY CHECKING THE DIPSTICK FREQUENTLY TO AVOID OVERFILLING.
- TO GET AN ACCURATE READING WHEN CHECKING THE OIL LEVEL:
 - ⇒ THE MACHINE SHOULD BE ON A LEVEL SURFACE.
 - ⇒ THE DIPSTICK SHOULD BE SCREWED DOWN ON BRIGGS & STRATTON ENGINES.

Capacities	
Briggs & Stratton Quantum Engine	SAE 30 – 20 oz. (.60L)
Gasoline Tank	Unleaded gasoline, 1.6 Qts. (1.5 L)

Tip: To avoid confusion, we recommend leaving the caps on the fuel and engine oil fills and only removing one cap each time when you are ready to pour gasoline or oil into the correct fill.

NOTE: Use SAE 30 high detergent oil classified “For Service SF, SG, SH, SJ” or higher. Do not use special additives. Other types of oil could cause problems operating your machine. Please refer to your Engine Owner’s Manual for detailed oil information.

1. Place the machine on a level surface and initially add 16 oz. (1/2 quart) of SAE 30 oil, recommended by the Engine Manufacturer, and wait one minute for the oil to settle (**Figure 7** on page 16).
2. Check the Dipstick and continue adding a few ounces of oil at a time, rechecking the Dipstick until the oil reaches the fill mark. Be careful not to overfill (**Figure 7** on page 16).

WARNING!

FILL GAS TANK OUTDOORS OR IN A WELL-VENTILATED AREA, AWAY FROM SPARKS, OPEN FLAMES, PILOT LIGHTS, HEAT, AND OTHER IGNITION SOURCES.

3. Fill the Gas Tank with fresh, unleaded gas (with a minimum of 85 Octane), to approximately 1" to 1-1/2" below the bottom of the fill neck to allow for fuel expansion (**Figure 7** on page 16). Be careful not to overfill and reinstall the cap before starting the Engine. See your Engine Owner’s Manual for more information.

NOTE: To refill the Gas Tank, turn the Engine OFF, and let the Engine cool at least two (2) minutes before removing the Gas Fill Cap.

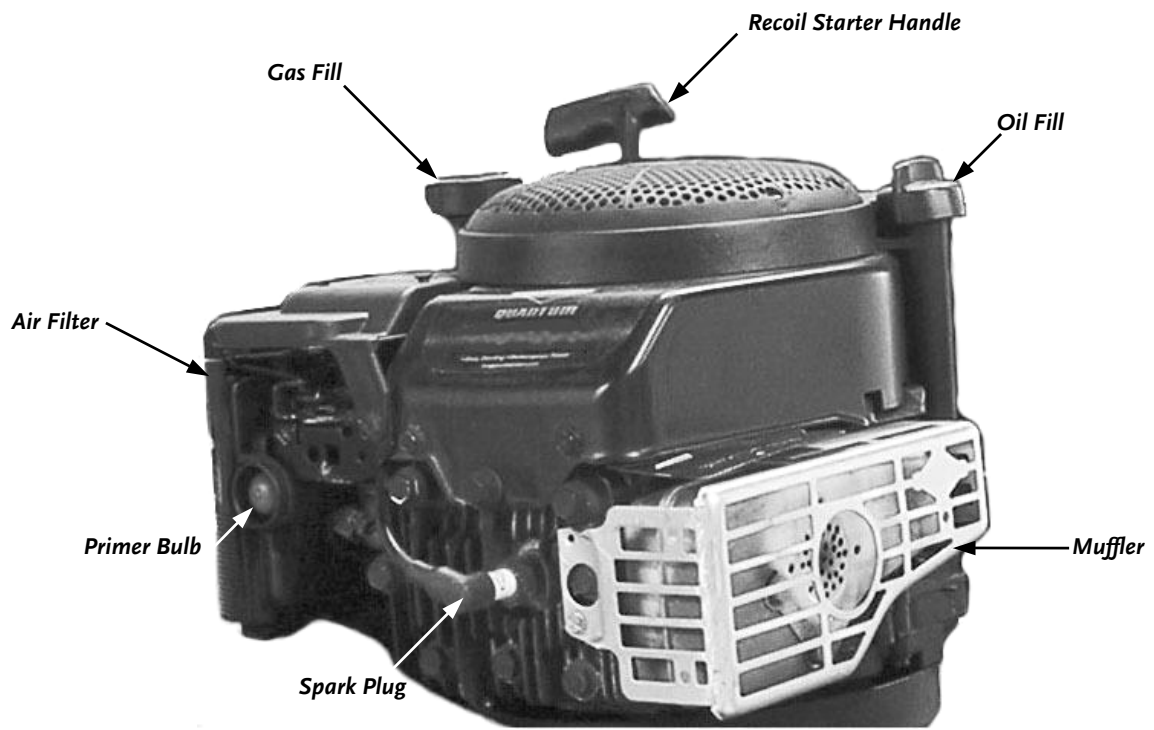

Figure 7

OPERATING YOUR DR WALK-BEHIND LEAF & LAWN VACUUM

This chapter covers the procedures for starting and stopping your new DR WALK-BEHIND LEAF & LAWN VACUUM and discusses basic operation features.

! WARNING!

- THE DESIGN OF THIS MACHINE IS FOR VACUUMING LEAVES, GRASS CLIPPINGS AND OTHER TYPES OF ORGANIC LITTER AS WELL AS DEBRIS MIXED WITH CANS, BOTTLES AND SMALL AMOUNTS OF SAND. NEVER USE THIS MACHINE FOR ANY OTHER PURPOSE AS IT COULD CAUSE SERIOUS INJURY.
- CONTACT WITH INTERNAL ROTATING PARTS WILL CAUSE SERIOUS PERSONAL INJURY. NEVER PUT HANDS, FACE, FEET, OR CLOTHING INTO THE NOZZLE OR NEAR THE DRIVE BELT WITH THE ENGINE RUNNING.
- BEFORE PERFORMING ANY MAINTENANCE PROCEDURE OR INSPECTION, STOP THE ENGINE, WAIT FIVE (5) MINUTES TO ALLOW ALL PARTS TO STOP AND COOL. DISCONNECT THE SPARK PLUG WIRE, KEEPING IT AWAY FROM THE SPARK PLUG.

Operator Controls

The Operator's Position is at the rear of the machine between the Handlebars. The Operator should stand in a position to grasp both Handlebars firmly, which allows sufficient leverage to steer the machine. See **Figure 8** for the Operator's controls.

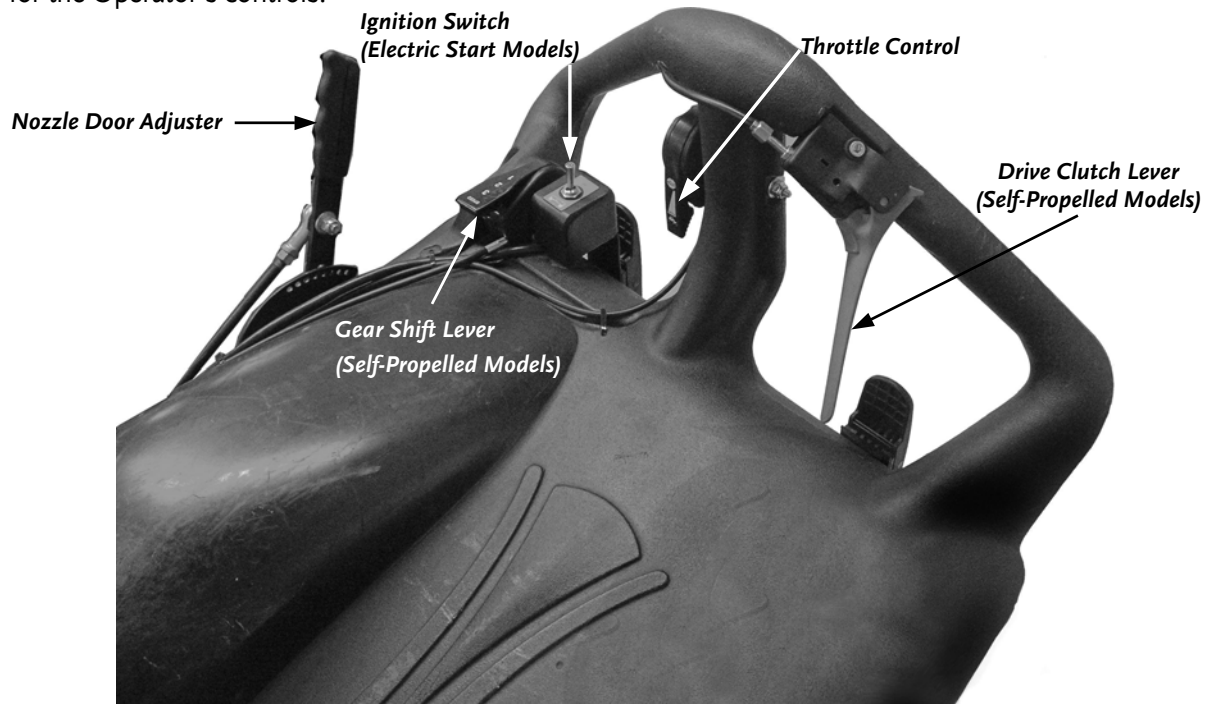

Figure 8

Before Starting the Engine

WARNING!

- INSPECT THE AREA WHERE YOU WILL BE WORKING. THE SITE MUST BE FREE OF POTENTIALLY HAZARDOUS OBSTACLES SUCH AS LARGE STONES OR STICKS. ALSO, MAKE SURE THERE WILL NOT BE PEOPLE OR ANIMALS IN THE AREA AROUND THE DR WALK-BEHIND LEAF & LAWN VACUUM.
- MAKE CERTAIN THAT THE DEBRIS BAG IS PROPERLY LATCHED IN PLACE.

1. Check the Engine oil level every time you use the machine (see **Figure 7** on page 16).
2. Check the gasoline level (see **Figure 7** on page 16).
3. Remove any built up debris from the Vacuum Nozzle.
4. Place the machine on level ground.

Manual-Starting

NOTE: You may use this starting method with both Manual and Electric Starting models; however, make sure the Electric Start Toggle Switch Lever is in the center position (straight UP) for the Electric Start models.

1. Push the Throttle Control Lever (**Figure 8** on page 17) all the way forward to the fast (Rabbit) position.
2. If your model has an Engine Primer, push the Primer Bulb IN (see **Figure 7** on page 16) and completely release it, lifting your finger and letting it pop back to its original position. Repeat three to four times.

NOTE: Priming is usually not necessary when restarting a warm Engine. In cool weather, you may need to repeat the priming procedure.

3. Grasp the Recoil Starter Handle (**Figure 7** on page 16) and slowly pull until you feel resistance. Let the cord retract a little bit, then pull the cord rapidly to start the Engine. One or two pulls usually starts the DR WALK-BEHIND LEAF & LAWN VACUUM. It may be necessary to repeat the priming operation if the machine does not start within two pulls.
4. Move the Throttle back to the desired operating speed; however, we recommend that you operate the Engine in the fast (Rabbit) position for optimum performance of the DR WALK-BEHIND LEAF & LAWN VACUUM.

Electric Starting

NOTE: Use the following steps with the Electric Starting model only.

1. Push the Throttle Control Lever (**Figure 8** on page 17) all the way forward to the fast (Rabbit) position.
2. If your model has an Engine Primer, push the Primer Bulb IN (see **Figure 7** on page 16) and completely release it, lifting your finger and letting it pop back to its original position. Repeat three to four times.

NOTE: Priming is usually not necessary when restarting a warm Engine. In cool weather, you may need to repeat the priming procedure.

3. Pull UP on the Electric Start Toggle Switch Lever and PUSH forward (**Figure 9**) to the START position until the Engine starts, then release. The Switch Toggle Lever will snap back to the center position and the Engine will continue to run.
4. Move the Throttle back to the desired operating speed; however, we recommend that you operate the Engine in the fast (Rabbit) position for optimum performance of the DR WALK-BEHIND LEAF & LAWN VACUUM.

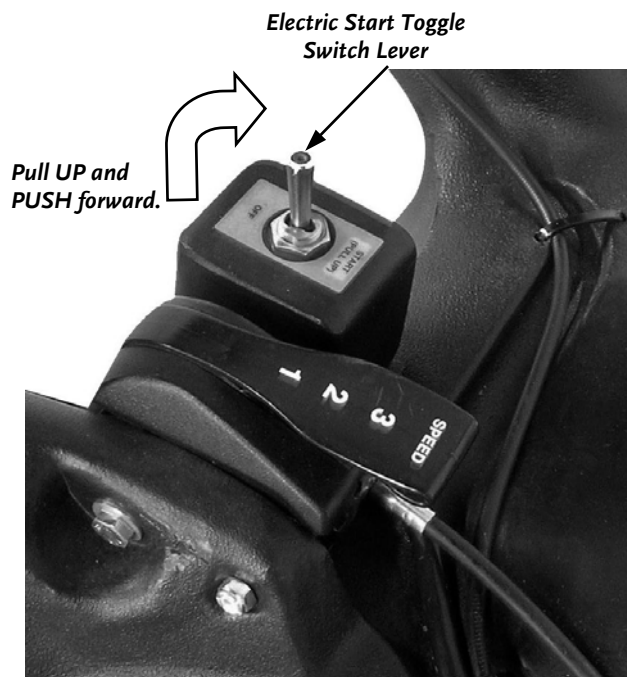

Figure 9

Stopping the Engine

Move the Throttle (**Figure 8** on page 17) all the way back to the STOP position.

NOTE: For the Electric Starting models, you can shut off the Engine by either moving the Throttle all the way back to the STOP position or moving the Throttle slowly to a slow Engine speed and moving the Electric Start Toggle Switch Lever to OFF. We recommend however, that you move the Throttle slowly to the STOP position to allow the motor to slow down before shutting it off.

Operating Safety

! WARNING!

- ALWAYS WEAR PROTECTIVE GOGGLES OR SAFETY GLASSES WITH SIDE SHIELDS WHILE OPERATING THIS VACUUM SYSTEM TO PROTECT YOUR EYES FROM POSSIBLE FOREIGN OBJECTS THROWN FROM THE MACHINE.
- AVOID WEARING LOOSE CLOTHING OR JEWELRY, WHICH MIGHT CATCH ON MOVING PARTS.
- WE RECOMMEND WEARING GLOVES WHILE VACUUMING. BE SURE YOUR GLOVES FIT PROPERLY AND DO NOT HAVE LOOSE CUFFS OR DRAWSTRINGS.
- WEAR SHOES WITH NON-SLIP TREADS WHEN USING YOUR VACUUM. IF YOU HAVE SAFETY SHOES, WE RECOMMEND WEARING THEM. DO NOT USE THE MACHINE WHILE BAREFOOT OR WEARING OPEN SANDALS.
- WEAR LONG PANTS WHILE OPERATING THE DR WALK-BEHIND LEAF & LAWN VACUUM.
- USE EAR PROTECTORS OR EAR PLUGS RATED FOR AT LEAST 20 DBA TO PROTECT YOUR HEARING.
- NEVER PUT YOUR HANDS INSIDE THE VACUUM NOZZLE TO CLEAR DEBRIS WHILE THE ENGINE IS RUNNING. ALWAYS STOP THE ENGINE AND DISCONNECT THE SPARK PLUG WIRE BEFORE CLEARING THE VACUUM NOZZLE.
- DO NOT REFUEL THE ENGINE WHILE IT IS HOT OR RUNNING.

! NOTICE!

USE COMMON SENSE WHEN USING THE MACHINE. LEARN TO RECOGNIZE THE CHANGE IN SOUNDS WHEN OVERLOADED. TURN OFF THE ENGINE IMMEDIATELY IF THE MACHINE BECOMES JAMMED TO PREVENT DAMAGE TO THE DRIVE SYSTEM.

Vacuum Nozzle Height Adjustment

For maximum pickup, adjust the Nozzle Height as close to the debris as possible, but without blocking airflow into the Nozzle.

NOTE: *Never bury the Nozzle into debris.*

To raise or lower the Vacuum Nozzle, turn the Crank Handle (**Figure 10**) counterclockwise to raise (UP), or clockwise to lower (DOWN).

Tip: For ease of adjustment, remove the weight from the front wheels by pushing down slightly on the handlebar while turning the Nozzle Height Adjustment Crank Handle.

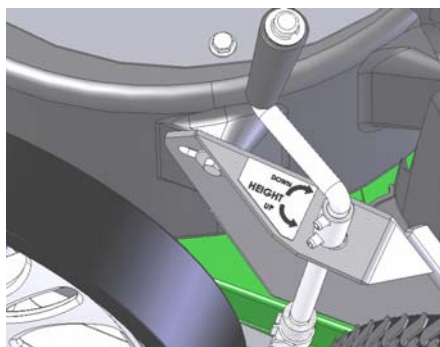

Vacuum Nozzle Door Operation

Figure 11 illustrates how the Vacuum Nozzle Door adjusts for the maximum performance under various applications.

Nozzle Door fully opened. This is ideal for turf application.



Nozzle Door opened half way. This is ideal for hard surface application.

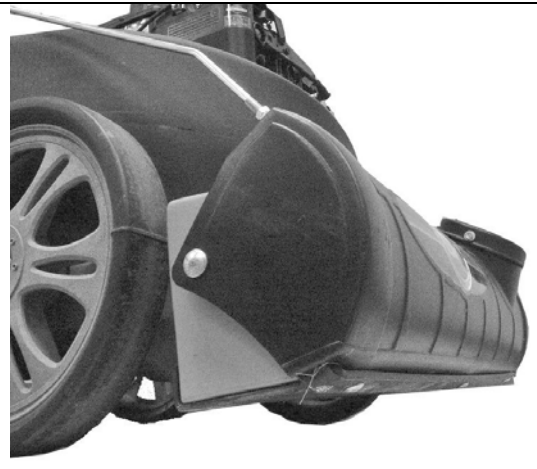

Nozzle Door closed for the OPTIONAL Hose Kit. This is ideal for hard to reach places.



Figure 11

Vacuuming Operation

The design of this machine is for vacuuming leaves, grass clippings, and other types of organic litter. You can also vacuum debris mixed with cans, bottles, and small amounts of sand.

Tip: Many vacuums are used where dust is mixed in with trash. Your machine can intermittently vacuum dusty areas. However, following these rules will help maintain your machine's ability to vacuum in dusty conditions.

- Run the engine at idle to about 1/4 Throttle.
- Machine wash or pressure-wash the Debris Bag if shaking and hosing down with a garden hose does not fully clean the Bag. The Bag should be thoroughly dry before use.
- For ease of cleaning and to extend the life of the Debris Bag, Optional Disposable Debris Bag Liners (P/N 21794) are available in a package of 12 through Country Home Products, Inc. See page 26.

! NOTICE!

DO NOT OPERATE THE VACUUM IF EXCESSIVE VIBRATION OCCURS. IF EXCESSIVE VIBRATION OCCURS, SHUT THE ENGINE OFF IMMEDIATELY AND CHECK FOR A DAMAGED OR WORN IMPELLER, LOOSE IMPELLER BOLT, LOOSE IMPELLER KEY, LOOSE ENGINE OR LODGED FOREIGN OBJECTS.

NOTE: See the "Removing and Replacing the Impeller" section on page 33 and the Troubleshooting section on page 43.

Self-Propelled Models:

1. Move the Gear Shift Lever (**Figure 12**) to the desired speed position (1, 2, or 3, see page 2).
2. Squeeze the Drive Clutch Lever (**Figure 13**) against the Handlebar to engage the Wheel Drive.

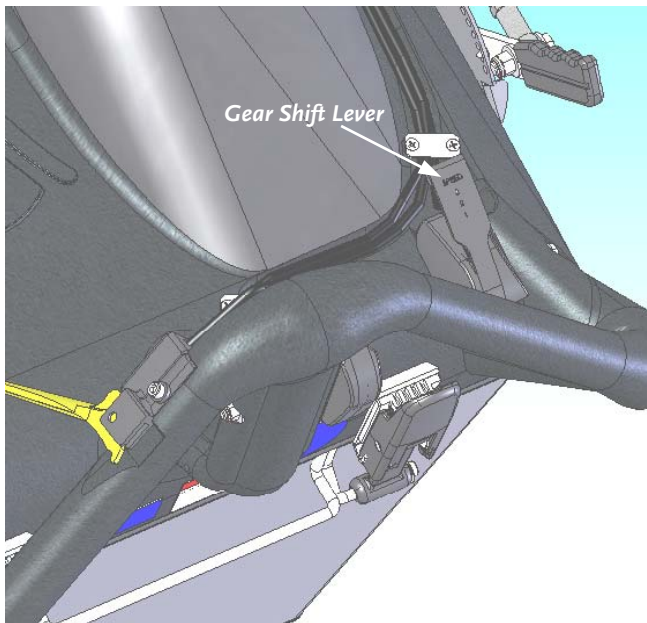

Figure 12

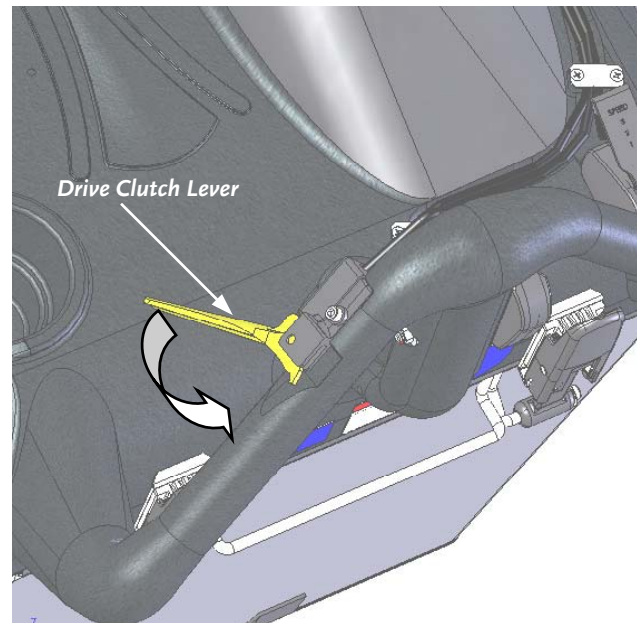

Figure 13

3. To stop and shut down the machine, release the Drive Clutch Lever to disengage the Wheel Drive and pull all the way back on the Throttle Control Lever (**Figure 8** on page 17) to the STOP position.

Slopes and Uneven Terrain

WARNING!

- WHEN OPERATING THE DR WALK-BEHIND LEAF & LAWN VACUUM OVER UNEVEN TERRAIN OR SLOPES, USE EXTREME CAUTION NOT TO LOOSE YOUR FOOTING OR TIP THE MACHINE OVER.
 - NEVER OPERATE YOUR MACHINE ON SLOPES GREATER THAN 20 DEGREES. DOING SO COULD RESULT IN SERIOUS INJURY OR DAMAGE TO YOUR MACHINE.
 - IF YOU HAVE TO VACUUM ON SLOPING TERRAIN, VACUUM ACROSS THE SLOPE, NOT UP AND DOWN, FOR BETTER CONTROL.
-

Clearing a Clogged Nozzle

WARNING!

- MOVE THE MACHINE TO LEVEL AREA BEFORE CLEANING.
 - BEFORE PERFORMING ANY MAINTENANCE PROCEDURE OR INSPECTION, STOP THE ENGINE, WAIT FIVE (5) MINUTES TO ALLOW ALL PARTS TO STOP AND COOL. DISCONNECT THE SPARK PLUG WIRE, KEEPING IT AWAY FROM THE SPARK PLUG.
 - WEAR DURABLE GLOVES WHEN CLEANING OUT THE NOZZLE. THE DEBRIS MAY CONTAIN SHARP OBJECTS.
-

1. Fully open the Nozzle Door (*Figure 11* on page 2`) and with a gloved hand, clean out any accumulated debris.

NOTE: You may have to carefully reach up and remove any debris from around the Impeller.

2. Reconnect the Spark Plug Wire.

Emptying the Debris Bag

WARNING!

- MOVE THE MACHINE TO LEVEL AREA BEFORE CLEANING.
- BEFORE EMPTYING THE DEBRIS BAG, BE SURE THAT THE ENGINE HAS COME TO A COMPLETE STOP.
- NEVER PLACE THE DEBRIS BAG ON OR NEAR A HOT SURFACE SUCH AS THE ENGINE.

CAUTION!

- EMPTY THE DEBRIS BAG FREQUENTLY TO PREVENT BAG OVERLOADING RESULTING IN MORE WEIGHT THAN YOU CAN LIFT.
- USE CAUTION AND WEAR GLOVES WHEN EMPTYING THE DEBRIS BAG.
- USE CAUTION AND ALWAYS WEAR GLOVES WHEN HANDLING A DEBRIS BAG THAT YOU HAVE USED FOR VACUUMING GLASS. MINUTE PARTICLES OF GLASS MAY REMAIN ON THE BAG SURFACE THAT MAY CUT YOU.
- NEVER REUSE A DEBRIS BAG TO COLLECT COMPOST MATERIAL THAT HAS BEEN USED PREVIOUSLY TO VACUUM GLASS. GROUND UP BOTTLES RESULT IN FINE DUST, BUT THE DUST WILL HAVE SHARP EDGES AND SHOULD NOT BE HANDLED OR EATEN. IF YOU ARE UNSURE OF THE PRESENCE OF GLASS, SUCH AS FROM VACUUMING A PARKING AREA, ROAD, OR SIDEWALK, DO NOT REUSE THE BAG FOR COMPOST. USE A NEW OR DEDICATED DEBRIS BAG TO OBTAIN COMPOST MATERIAL AND USE THE OTHER BAG FOR DEBRIS.
- WE RECOMMEND CHANGING BOTH THE INNER LINER AND THE OUTER BAG AFTER VACUUMING GLASS AND OTHER DEBRIS AND BEFORE USING THE SYSTEM TO VACUUM MATERIAL THAT MAY BE USED FOR COMPOST OR MULCH.
- ALSO, EMPTY THE DEBRIS BAG FREQUENTLY TO PREVENT SPONTANEOUS COMBUSTION DUE TO DECAYING MATERIAL.
- WHEN REPLACING THE DEBRIS BAG, ALWAYS CHECK FOR TEARS OR PIN HOLES AND MAKE SURE YOU HAVE A GOOD SEAL BETWEEN THE BAG FRAME AND THE TOP SHIELD ASSEMBLY.

1. Unhook the two (2) Rubber Flexible Latches from the Latch Plates on the Top Shield Assembly. See **Figure 14b** on page 25.
2. Slide the Debris Bag frame all the way out of the Top Shield Assembly channels, supporting the frame so as not to drop it after removing from the channels.
3. Empty the Debris Bag in a suitable location.
4. Replace the Debris Bag in the reverse order, making sure that the Bag Presence Interlock Switch is properly engaged (see **Figure 14c** on page 25).

NOTE: Debris Bags are normal replaceable wear items not covered under the warranty. An Optional Disposable Debris Bag Liner (P/N 21794) is available in a package of twelve (12) through Country Home Products, Inc. to help extend the life the Debris Bag. See the next page for installing and removing the Optional Debris Bag Liner.

Attaching the Debris Bag

The following procedure in **Figure 14** illustrates the steps necessary for attaching the Debris Bag to the Top Shield Assembly on the DR WALK-BEHIND LEAF & LAWN VACUUM.

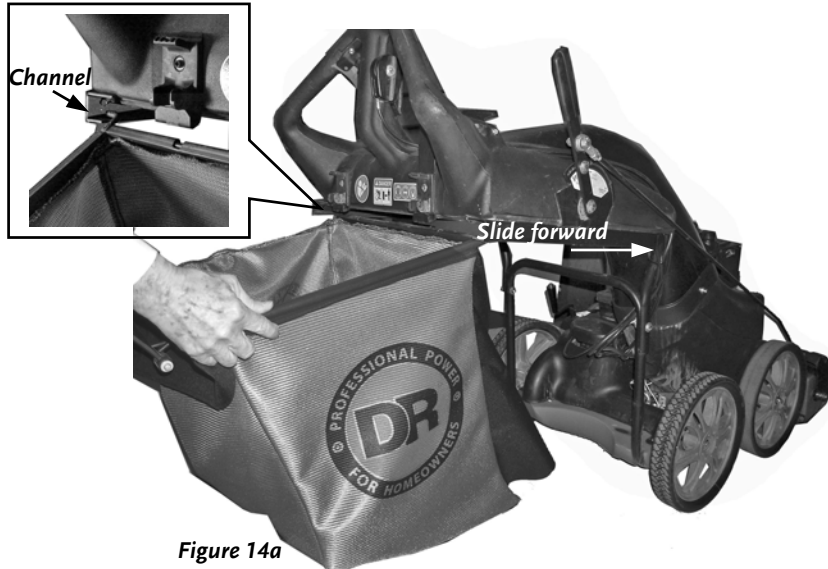

Figure 14a

1. Place the Left and Right ends of the Debris Bag frame into the Left and Right Channels in the Top Shield Assembly (**Figure 14a**).

2. Slide the Debris Bag all the way forward in the Top Shield Assembly channels (**Figure 14a**).

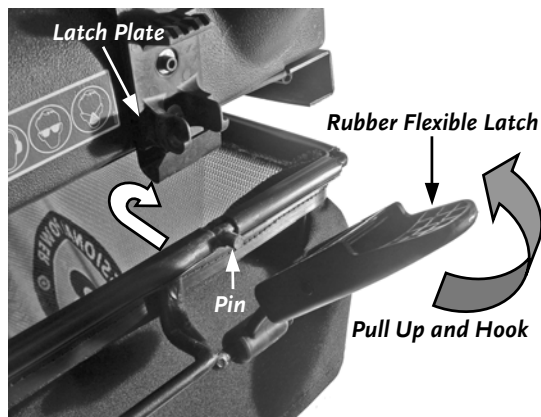

Figure 14b

3. Lift the Debris Bag making sure that the pins on the Frame (**Figure 14b**) go behind the Latch Plates and then lift and hook the two (2) Rubber Flexible Latches on to the Latch Plates on the Top Shield Assembly.



Figure 14c

NOTE: Also, make sure that the Bag Presence Interlock Switch is engaged by the Debris Bag frame (button pushed in) or the Engine will not start (**Figure 14c**).

Installing the Optional Disposable Debris Bag Liner (P/N 21794, package of 12)

The Optional Disposable Debris Bag Liner extends the life of the Debris Bag and provides a convenient way to empty the Debris Bag.

1. Unhook the two (2) Rubber Flexible Latches from the Latch Plates on the Top Shield Assembly. See **Figure 14b** on page 25.

2. Slide the Debris Bag Frame all the way back in the Top Shield Assembly channels.

Tip: To hold the Frame, place the Frame Support into the slot provided in the side of the Top Shield Assembly (**Figure 15a**).

3. Unfold a Bag Liner, shape it, and insert the Liner into the Debris Bag (**Figure 15b**).

4. Fold the Liner opening over the top of the Debris Bag frame and punch the liner through the Retaining Pins on the outside of the front Bag Frame to hold the Liner in place (**Figure 15b**).

5. Place the Debris Bag frame, with the Liner in place, in the channels and slide the frame all the way forward and re-connect the two (2) Flexible Latches making sure that the Bag Presence Interlock Switch is properly engaged (see **Figure 14c** on page 25) and there is a good seal between the Bag Frame and the Top Shield Assembly.

6. To empty a Bag Liner, follow steps 1 and 2 but remove the Bag Frame from the channels in the Top Shield Assembly and allow the full bag to stand upright on the ground.

7. Unhook the Disposable Debris Bag from the pins on the Bag Frame, allowing the Bag Frame and the outer Debris Bag to fall away leaving the Disposable Bag standing free.

8. Properly dispose the full Bag Liner and replace with a new Bag Liner in the reverse order, making sure that the Bag Presence Interlock Switch is properly engaged (see **Figure 14c** on page 25) and there is a good seal between the Bag Frame and the Top Shield Assembly.

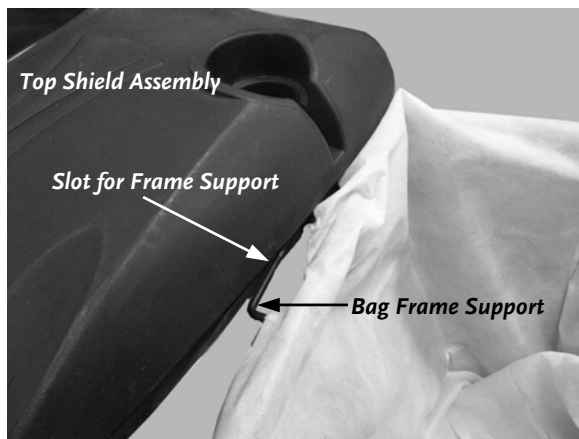

Figure 15a



Figure 15b

Handling and Transporting



NEVER LIFT THE MACHINE WHILE THE ENGINE IS RUNNING.

We recommend using two (2) people to lift the DR WALK-BEHIND LEAF & LAWN VACUUM. Lift the machine holding the Handle and the front of the Nozzle. Make sure to properly secure the vacuum in the transporting vehicle.

CHAPTER 5

MAINTAINING THE DR WALK-BEHIND LEAF & LAWN VACUUM

This chapter covers regular maintenance procedures that will ensure the best performance and long life of your DR WALK-BEHIND LEAF & LAWN VACUUM. For engine maintenance, please refer to the Engine Owner's Manual that came with your DR WALK-BEHIND LEAF & LAWN VACUUM. Service intervals listed in the checklist below supercede those listed in the Engine Owner's Manual.

WARNING!

WHEN PERFORMING ANY MAINTENANCE, YOU MUST FIRST SHUT OFF THE ENGINE, WAIT FIVE (5) MINUTES TO ALLOW PARTS TO COOL AND DISCONNECT THE SPARK PLUG WIRE, KEEPING IT AWAY FROM THE SPARK PLUG.

Regular Maintenance Checklist

NOTE: Consider that the service intervals shown are the maximum under normal operating conditions. Increase frequencies under extremely dirty or dusty conditions.

Procedure	Before Each Use	Every 8-10 Hours	Every 25 Hours	Every 50 Hours
Check the Engine Oil Level.	▲			
Clean the Debris Bag.	▲			
Check the general condition of the machine, e.g. nuts, bolts, welds, etc.	▲			
Clean Engine Exterior & Cooling Fins	▲			
Check Battery Voltage (Electric Start Model)		▲		
Inspect the *Drive Belt for wear.			▲	
Lubricate Control Cables.			▲	
Lubricate *Drive Chain.			▲	
Check *Drive Clutch Cable tension.				▲
Change Engine Oil and Filter** NOTE: 1 st time 5 hrs.				▲
Replace Air Filter and Pre-cleaner**				▲
Replace the *Drive Belt.				▲
Replace Spark Plug				▲

* Applicable to Self-Propelled models.

** The engine on your DR WALK-BEHIND LEAF & LAWN VACUUM may not have a Pre-cleaner or Oil Filter.

Lubrication

WARNING!

WHEN PERFORMING ANY MAINTENANCE, YOU MUST FIRST SHUT OFF THE ENGINE, WAIT FIVE (5) MINUTES TO ALLOW PARTS TO COOL AND DISCONNECT THE SPARK PLUG WIRE, KEEPING IT AWAY FROM THE SPARK PLUG.

Your DR WALK-BEHIND LEAF & LAWN VACUUM was lubricated at the Factory. The operator needs to provide engine lubrication and lubricate the Throttle Control Cable, *Drive Clutch Cable, *Drive Chain, and the *Gear Shift Cable periodically.

Supplies Needed:

- FLUID FILM® or comparable lubricant
 - 7/16" Socket with 6" Extension (Self-Propelled model)
1. Lubricate the Throttle Control Cable, *Drive Clutch Cable and the *Gear Shift Cable (**Figure 16**) with FLUID FILM® or comparable lubricant. Spray the lubricant into the cable housing while working the cable back and forth a few times.
 2. Perform this lubrication at both ends of the cables. The *Drive Clutch Cable and *Gear Shift Cable are shown in **Figure 17**. Remove the *Drive Belt Cover (**Figure 19** on page 33) using a 7/16" Socket with a 6" Extension to remove the four (4) 1/4" Cover Bolts.
 3. With the *Drive Belt Cover removed, lubricate the *Drive Chain with FLUID FILM® or comparable lubricant (**Figure 22** on page 37).
 4. Perform these lubrications more often in dry and dusty environments.

* Applicable to the Self-Propelled models.

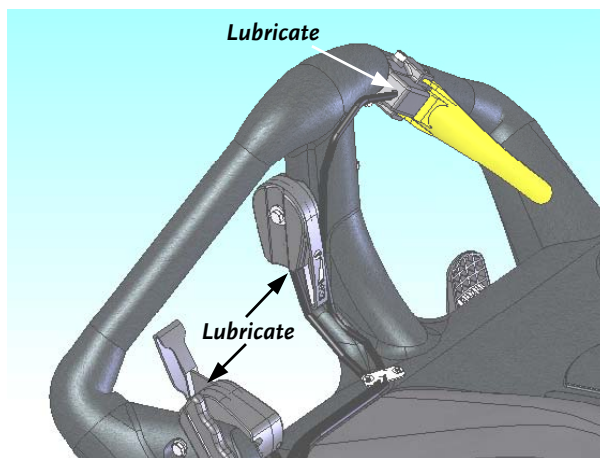

Figure 16

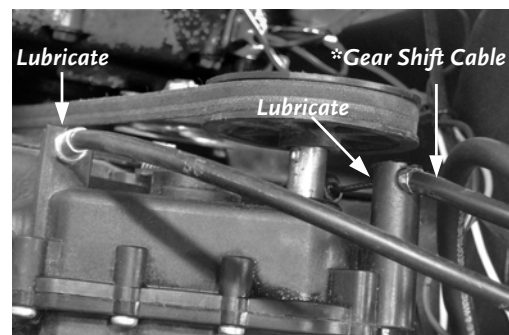

Figure 17

Removing and Replacing the Engine Oil

! WARNING!

WHEN PERFORMING ANY MAINTENANCE, YOU MUST FIRST SHUT OFF THE ENGINE, WAIT FIVE (5) MINUTES TO ALLOW PARTS TO COOL AND DISCONNECT THE SPARK PLUG WIRE, KEEPING IT AWAY FROM THE SPARK PLUG.

! NOTICE!

BE CERTAIN TO FILL THE ENGINE WITH OIL BEFORE STARTING. SEE PAGE 15.

Tools & Supplies Recommended:

- Vacuum Pump Oil Drainer
- SAE 30 HD, 20 oz. (0.60L)

NOTE: Remove the oil when the Engine is warm. Warm oil flows quickly and completely.

1. Remove the Oil Fill Cap and vacuum the oil from the engine through the Oil Fill Tube (**Figure 18**) using a Vacuum Pump Oil Drainer.
2. Replace the oil by following the instructions on page 15.
3. Reattach the Spark Plug wire.

NOTE: Be sure to use environmentally safe disposal procedures in the disposing of the used oil.

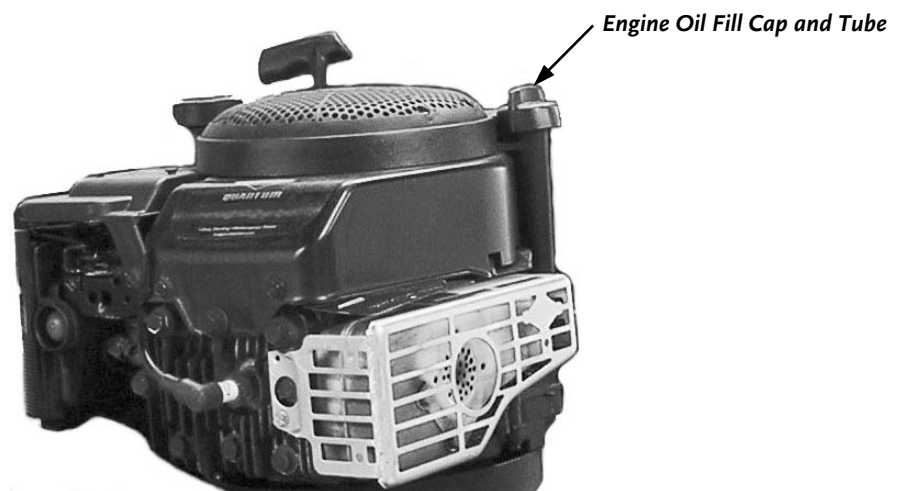

Figure 18

Battery Care (For Electric-Starting Models)

Proper care can extend the life of a Battery. Follow these recommendations to ensure your Battery's best performance and long life:

- Do not allow the Battery charge to get too low. If the machine is not used, charge the Battery every 4 – 6 weeks. Operate the Engine for at least 45 minutes to maintain proper Battery charge.
- Store an unused Battery in a dry area that does not freeze.
- Do not charge an already charged Battery. In theory, you cannot overcharge our Battery with a trickle charger; however, when a Battery is fully charged and the charger is still on, it generates heat that could be harmful to the Battery. A fully charged Battery will read 12V-13.2V with a voltmeter.
- Do not continue to crank your Engine when the Battery charge is low.

Charging the Battery

Operate the Engine for at least 45 minutes to maintain proper Battery charge. If the Battery loses its charge, you will need to use a trickle charger (like the DR Battery Charger) to recharge it. The Charger should have an output of 12 volts at no more than 2 amps.

- At 1 amp, the Battery may need charging for as long as 48 hours.
- At 2 amps, the Battery may need charging for as long as 24 hours.

NOTE: *Using the Recoil Starter and then running the Engine will not recharge a dead or significantly discharged Battery.*

To connect a Battery Charger to your DR WALK-BEHIND LEAF & LAWN VACUUM, follow the steps listed below.

1. Detach the two (2) Battery cables going to the Battery on your machine.
2. Attach the black (-) Battery Charger wire to the Battery negative (-) terminal, and attach the red (+) Battery Charger wire to the Battery positive (+) terminal.
3. Plug the Battery Charger into an outlet.

NOTICE!

WHEN YOU ARE FINISHED CHARGING THE BATTERY, DISCONNECT THE CHARGER FROM THE OUTLET FIRST, THEN DISCONNECT THE BATTERY CHARGER WIRES FROM THE BATTERY. IF YOU LEAVE THE BATTERY CHARGER WIRES CONNECTED TO THE BATTERY, THE BATTERY WILL DISCHARGE ITSELF BACK INTO THE CHARGER.

Removing and Replacing the Impeller

! WARNING!

WHEN PERFORMING ANY MAINTENANCE, YOU MUST FIRST SHUT OFF THE ENGINE, WAIT FIVE (5) MINUTES TO ALLOW PARTS TO COOL AND DISCONNECT THE SPARK PLUG WIRE, KEEPING IT AWAY FROM THE SPARK PLUG.

Tools and Supplies Needed:

- 9/16" Socket w/Extension and Universal Joint
- 7/16" Socket with 6" Extension
- (2) Pry Bar or Long Bladed Screwdriver
- Jack Stands or blocks to support the machine
- Anti-Seize Compound (recommended)
- Torque Wrench (0-50 ft-lbs.)

Removing the Impeller:

1. Drain the fuel and oil from the vacuum. See page 35.
2. Remove the Belt Cover using a 7/16" Socket with a 6" Extension to remove the four (4) 1/4" Cover Bolts (**Figure 19**).
3. Detach the Drive Belt from the Transmission Pulley by rotating the Transmission Assembly to relieve the Belt tension.
4. Using a 7/16" Socket with 6" Extension, remove the six (6) 1/4" Bolts, Lock Washers and Flat Washers (**Figure 20**) attaching the Engine Mounting Plate to the Impeller Housing.
5. Remove the Engine, Impeller and Mounting Plate, as an assembly, by inverting and supporting the Engine on it's top with the Impeller facing up so as not to damage the Recoil Starter.
6. Leaving the Engine attached to the Mounting Plate and using a 9/16" Socket, remove the Impeller Bolt and Lock Washer and then slide the Impeller off the Engine Crankshaft (**Figure 20**).

Tip: A gear or wheel puller may be helpful.

NOTE: Do not drop the Impeller.

7. If the Impeller does not slide off the Engine Crankshaft, place two (2) Pry Bars between Impeller and Mounting Plate on opposite sides. Carefully and evenly, pry the Impeller away from Engine until it loosens.

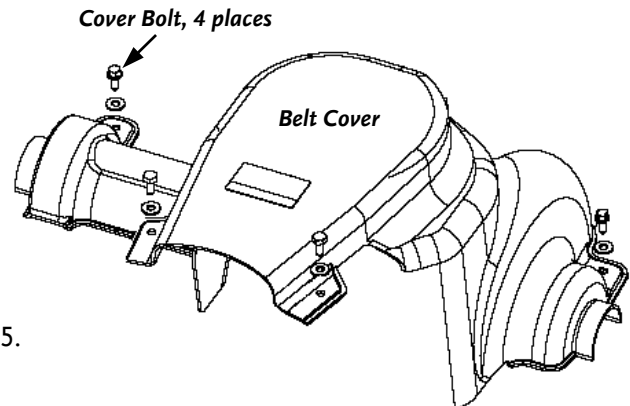

Figure 19

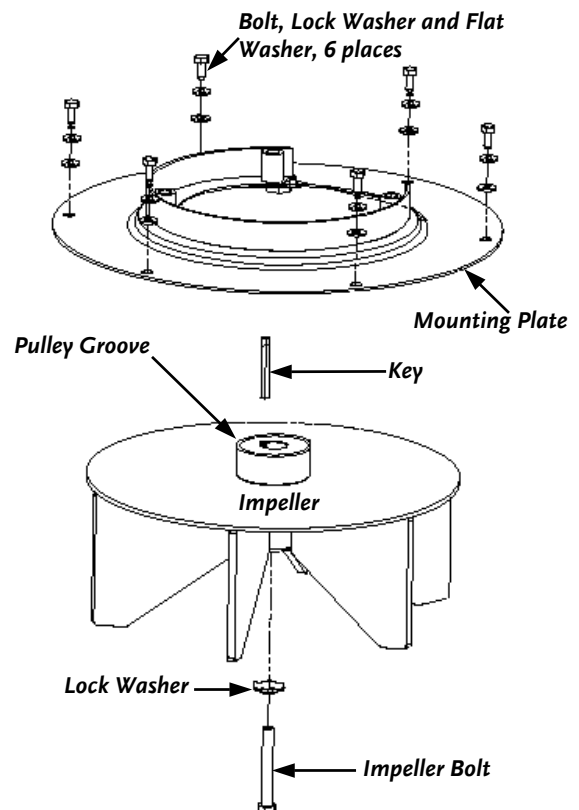

Figure 20

Tip: Using a penetrating oil can help loosen a stuck Impeller.

8. If you still cannot loosen the Impeller, obtain a 3/8"-24 x 3-3/4" Bolt, and thread the Bolt by hand into the Engine Crankshaft until the Bolt bottoms out. Using a suitable gear or wheel puller against the Bolt Head and the backside of the Impeller (near the blades), remove the Impeller from the Crankshaft.

NOTE: Make sure that the Key stays in the Keyway in the Engine Crankshaft (**Figure 20** on page 33).

Replacing the Impeller:

1. Apply a thin coat of Anti-Seize Compound to the Engine Crankshaft and reinstall the Impeller by aligning the Key in the Crankshaft with the Keyway in the Impeller (**Figure 20** on page 33).

NOTE: Use a new Impeller Cap Screw (3/8"-24 x 2-3/4" w/Patch Lock) and a new Lock Washer (3/8" Twisted Tooth) when reinstalling the Impeller.

2. Tighten the Impeller Bolt and torque to 50 ft.-lbs.
3. Reinstall the Engine, Impeller, and Mounting Plate on the Impeller Housing in the reverse order of removal.
4. Before connecting the Spark Plug wire, slowly pull the Recoil Starter Handle to insure that the Impeller rotates freely within the housing.



BE CERTAIN TO FILL THE ENGINE WITH OIL BEFORE STARTING. SEE PAGE 15.

5. Reconnect the Spark Plug wire.

Drive Clutch Cable Adjustment

! WARNING!

WHEN PERFORMING ANY MAINTENANCE, YOU MUST FIRST SHUT OFF THE ENGINE, WAIT FIVE (5) MINUTES TO ALLOW PARTS TO COOL AND DISCONNECT THE SPARK PLUG WIRE, KEEPING IT AWAY FROM THE SPARK PLUG.

Tools Needed:

- 7/16" Socket with 6" Extension
- (2) 1/2" Wrench
- Tape Measure

1. Remove the Belt Cover using a 7/16" Socket with a 6" Extension to remove the four (4) 1/4" Cover Bolts (**Figure 19** on page 33).
2. Pull the machine backward and squeeze the Drive Clutch Lever until it stops freewheeling. At this point, the Drive Clutch Lever should be about 4" from the tip of the Lever to the Handlebar (**Figure 21a**).
3. Measure the amount of Clutch Spring stretch (**Figure 21b**). The Clutch Spring should measure 1-1/8" when engaged.

Tip: Either tie the Drive Clutch Lever to the Handlebar or have someone hold it for you during the measurement.

4. Using two (2) 1/2" Wrenches, loosen the Lock Nut and then tighten or loosen the Cable Adjuster Nut in front of the Drive Clutch Lever (**Figure 21a**) until you obtain the 4" distance as noted in step 2.
5. Holding the Adjuster Nut in place with one Wrench, tighten Cable Lock Nut firmly with the other (**Figure 21a**).
6. Release the Drive Clutch Lever and then move it to the Handlebar again and hold it. Check the Clutch Spring length to assure it stayed in adjustment.
7. Readjust as required.
8. Reinstall the Belt Cover and reconnect the Spark Plug Wire.
9. Test run the DR WALK-BEHIND LEAF & LAWN VACUUM to insure proper operation after this or any other maintenance procedure.

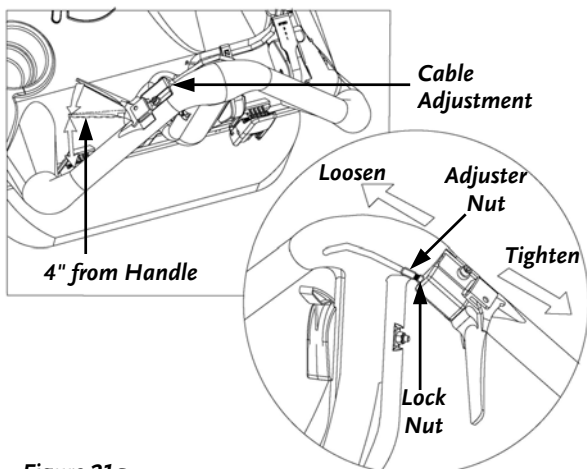

Figure 21a

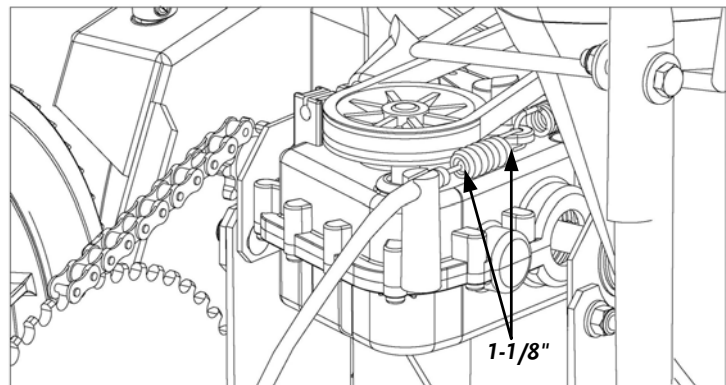

Figure 21b

Removing and Replacing the Drive Belt

WARNING!

WHEN PERFORMING ANY MAINTENANCE, YOU MUST FIRST SHUT OFF THE ENGINE, WAIT FIVE (5) MINUTES TO ALLOW PARTS TO COOL AND DISCONNECT THE SPARK PLUG WIRE, KEEPING IT AWAY FROM THE SPARK PLUG.

Tools Needed:

- 7/16" Socket with 6" Extension
- 5/16" Socket or Nut Driver

1. Remove the Belt Cover using a 7/16" Socket with a 6" Extension to remove the four (4) 1/4" Cover Bolts (**Figure 19** on page 33).
2. Using a 5/16" Socket or Nut Driver, loosen the cable clamp and remove the Throttle Cable from the Engine.
3. Unplug the Wiring Harness wire at the Engine.
4. Tilt the Transmission Input Pulley toward the Engine and remove the Belt upward from the Pulley.
5. Using a 7/16" Socket with 6" Extension, remove the six (6) 1/4" Bolts, Lock Washers and Flat Washers (**Figure 20** on page 33) attaching the Engine Mounting Plate to the Impeller Housing.

Tip: For the next step, we suggest that you have another person help hold the Engine while the Belt is changed, or, drain the gas and oil and carefully set the engine on its side. Have a new Belt within reach to hasten the Belt change.

6. Remove the Engine, Impeller, and Mounting Plate, as an assembly, from the Impeller Housing.
7. Slide the Belt out from around the Impeller pulley groove under the Engine and off downward around Impeller.
8. Install a new Belt in the reverse order of the Belt removal.

NOTE: Before placing the new Belt on the Transmission Pulley and before placing the Impeller back in the Impeller Housing, look between the Engine Mounting Plate and the Impeller to insure the Belt is in the Groove of the Impeller Pulley (**Figure 20** on page 33).

9. Install the Engine, Impeller, and Mounting Plate, as an assembly, back into the Impeller Housing in the reverse order of removal.

Tip: Put a little tension on the new Belt as you lower the Engine, Impeller, and Mounting Plate back into the Impeller Housing by gently pulling the Belt toward the Transmission Input Pulley. This will keep the Belt in the Impeller Pulley Groove during assembly.

10. Tilt the Transmission Input Pulley toward the Engine and install the new Belt on the Transmission Input Pulley.
11. Reconnect the Spark Plug wire.

Drive Chain Replacement, Alignment and Tension

! WARNING!

WHEN PERFORMING ANY MAINTENANCE, YOU MUST FIRST SHUT OFF THE ENGINE, WAIT FIVE (5) MINUTES TO ALLOW PARTS TO COOL AND DISCONNECT THE SPARK PLUG WIRE, KEEPING IT AWAY FROM THE SPARK PLUG.

Tools Needed:

- 7/16" Socket with 6" Extension
- (2) 1/2" Wrench or Socket
- Needle-Nosed Pliers
- Flat Head Screwdriver
- Pry Bar

Chain Removal and Replacement:

1. Block up the machine so that the rear Wheels are off the ground.
2. Remove the Belt Cover using a 7/16" Socket with a 6" Extension to remove the four (4) 1/4" Cover Bolts (**Figure 19** on page 33).
3. Using two (2) 1/2" Wrenches or Sockets, loosen the left side (viewed from behind Handlebars) Axle Bearing Mount Bolts and then slide the Bearing forward to the end of its travel (**Figure 22**).
4. Rotate the Left Rear Wheel to bring the Drive Chain "Master Link" into view on the Axle Sprocket (**Figure 22**).
5. Remove the Master Chain Link (**Figure 23**). First, remove the Lock Clip by spreading the Clip with a Screwdriver and at the same time, slide the Lock Clip back off the Master Link pins with the Needle-Nosed Pliers. Next, remove the Side Plate, and then remove the Master Chain Link.

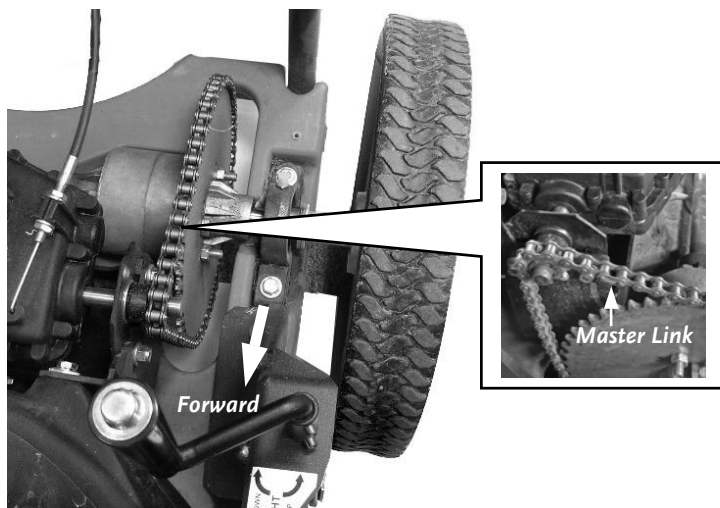

Figure 22

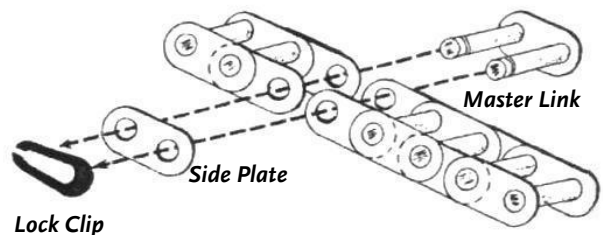

Figure 23

6. Slowly feed out the old Drive Chain and remove the Chain.
7. Thread the new Drive Chain onto the sprockets.

Tip: Place the ends of the Chain on the Axle Sprocket; this makes it easier to hold the Chain in place when you slide the new Master Link in place.

8. Carefully install the Master Chain Link (**Figure 23** on page 37) in the reverse order of step 5, making sure that the Lock Clip is securely in place.
9. Slide the Axle Bearing Mount toward the rear of the machine, to take up the slack of the Chain, and loosely tighten the Bearing Mount Bolts just enough to hold it in place but leaving it movable.
10. Rotate the Left Rear Wheel to find the location where the Drive Chain is tightest, since there are always slight variations in the sprockets that make the Chain tighter at certain places in its rotation.
11. At the point where the Chain is the tightest, slide the Axle Bearing Mount very slightly forward to achieve a total slack (up and down travel) of 1/4" to 1/2" in the Chain when measured halfway between the Axle Sprocket and the Transmission Sprocket, and then tighten the Axle Bearing Mount Bolts.
12. Rotate the Left Rear Wheel several times and listen for a "popping" or "cracking" noise. This noise indicates too much tension on the Chain. If this is the case, loosen the Axle Bearing Mount Bolts and slide the Mount very slightly forward to loosen the Chain just a little, and then recheck it.
13. Retighten the Axle Bearing Mount Bolts and re-install the Belt Cover.
14. Reconnect the Spark Plug wire.

Throttle Cable Adjustment

! WARNING!

WHEN PERFORMING ANY MAINTENANCE, YOU MUST FIRST SHUT OFF THE ENGINE, WAIT FIVE (5) MINUTES TO ALLOW PARTS TO COOL AND DISCONNECT THE SPARK PLUG WIRE, KEEPING IT AWAY FROM THE SPARK PLUG.

Tool Needed:

- 5/16" Socket or Nut Driver
1. Using a 5/16" Socket or Nut Driver, loosen the Bowden Clamp holding the Throttle Cable Sheath to the Engine (**Figure 24**).
 2. Pull the Throttle Control Lever up and all the way back to the STOP position. Note the location of the End of the Throttle Cable Sheath (**Figure 24**).
 3. Slowly move the Throttle Control Lever forward until the Throttle Cable Sheath travels about 1/8" from the noted location in step 2.
 4. Hold the Throttle Cable Sheath in place and tighten the Bowden Clamp.
 5. Check the travel of the Throttle Control Lever to make sure the STOP and FAST positions are attainable.

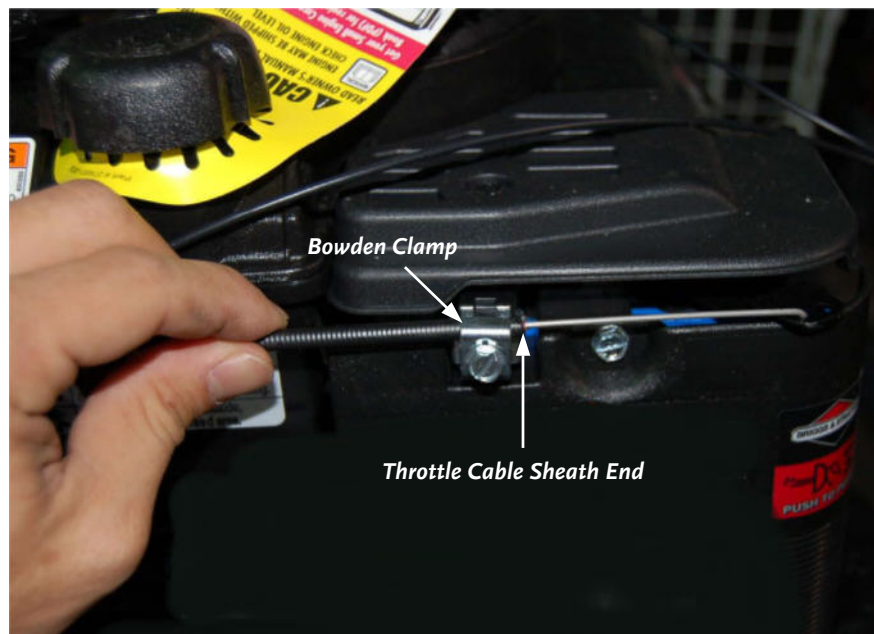

Figure 24

Disposing of the Battery Responsibly (Electric-Start Models)

The Battery is a sealed lead-acid Battery. Recycle or dispose of it in an environmentally sound way.

- Do not dispose of a lead-acid Battery in a fire; the Battery may explode or leak.
- Do not dispose of a lead-acid Battery in your regular, household trash. Law in most areas prohibits incinerating, disposing in a landfill, or mixing a sealed lead-acid Battery with household trash.

Recycling a Used Battery



NOTICE!

PLEASE DISPOSE OF USED BATTERIES RESPONSIBLY, ACCORDING TO YOUR LOCAL HAZARDOUS MATERIALS REGULATIONS. NEVER THROW AWAY USED BATTERIES IN YOUR HOUSEHOLD TRASH.

Please dispose of your used Batteries responsibly by recycling them. Call your local Solid Waste Management District or your local waste handler to locate the collection site nearest you. Some collection sites recycle Batteries year-round; others collect them periodically.

You can also visit the Web site of Earth 911 for more information [www.earth911.org]. Once there, click the Municipal HHW link under Hazardous Household Waste, and enter your zip code. The site lists recycling centers located near you.

For a fee, you can recycle your Batteries with the International Metals Reclamation Company. Visit them at www.inmetco.com and click Services; or contact them at:

INMETCO
PO Box 720
245 Portersville Road
Ellwood City, PA 16117
(724) 758-2825; fax (724) 758-2845

To learn more about hazardous waste recycling, visit the Web site for Battery Council International [www.batterycouncil.org] or for the Environmental Protection Agency [www.epa.gov].

End of Season and Storage

WARNING!

- **WHEN PERFORMING ANY MAINTENANCE, YOU MUST FIRST SHUT OFF THE ENGINE, WAIT FIVE (5) MINUTES TO ALLOW PARTS TO COOL AND DISCONNECT THE SPARK PLUG WIRE, KEEPING IT AWAY FROM THE SPARK PLUG.**
 - **EMPTY THE DEBRIS BAG TO PREVENT SPONTANEOUS COMBUSTION DUE TO DECAYING MATERIAL.**
-

NOTE: Please refer to the Engine Owner's Manual for Engine-specific procedures.

- Change the oil.
- If your DR WALK-BEHIND LEAF & LAWN VACUUM will be idle for more than 30 days, we recommend using a gas stabilizer. This will prevent sediment from gumming up the Carburetor. If there is dirt or moisture in the gas or tank, remove it by draining the tank. Completely fill the tank with fresh, unleaded gas and add the appropriate amount of stabilizer or gasoline additive. Run the Engine for a short time to allow the additive to circulate.
- Remove the Spark Plug and pour about 1 ounce of motor oil into the Cylinder hole. Replace the Plug and pull the Recoil Starter Rope until you feel strong resistance. This will coat the piston and seat the valves to prevent moisture buildup.
- Clean or replace the Air Filter.
- Clean dirt and debris from the Cylinder Head Cooling Fins, Impeller Housing, Debris Screen, and Muffler area of the Engine.
- Clean out residual debris from the Nozzle.
- Clean the Debris Bag. See page 24.
- For Electric-Start models, store the Battery in a dry area that will not freeze. If you will not use the machine over a long period, charge the Battery every four to six weeks. See page 32.

TROUBLESHOOTING

Most problems are easy to fix. Consult the Troubleshooting Table for common problems and their solutions. If you continue to experience problems, call Country Home Products, Inc. for support.

Troubleshooting Table



WHEN PERFORMING ANY MAINTENANCE, YOU MUST FIRST SHUT OFF THE ENGINE, WAIT FIVE (5) MINUTES TO ALLOW PARTS TO COOL AND DISCONNECT THE SPARK PLUG WIRE, KEEPING IT AWAY FROM THE SPARK PLUG.

SYMPTOM	POSSIBLE CAUSE
<p><i>Recoil will not pull out or is difficult to pull.</i></p>	<ul style="list-style-type: none"> ⇒ Check for debris in the Impeller Housing. ⇒ Check the Engine oil level; the Engine may be seized. ⇒ There may be an oil compression lock in the cylinder. Take out the Spark Plug; hold a rag over the Spark Plug hole and pull the Recoil Cord several times to blow out any oil in the cylinder. Wipe off the Spark Plug and reinstall it. ⇒ The Recoil may be broken or jammed. Call 1-800-DR-OWNER (376-9637) for assistance.
<p><i>The Engine will not start manually.</i></p> <p><i>(Please refer to the Engine Owner's Manual for Engine-specific procedures.)</i></p>	<ul style="list-style-type: none"> ⇒ Check that the Spark Plug Wire is attached. ⇒ Check that the Bag is properly installed, latched, and the Bag Presence Interlock Switch is depressed. See page 18 Figure 14c. Also, check that the Bag frame rod is not bent. ⇒ Check the oil and gas level. See page 15. ⇒ The gas may be old, change it. Use a fuel stabilizer if you keep gas longer than one month. ⇒ Check the Throttle adjustment and travel. See page 39. ⇒ The Spark Plug may be dirty or cracked, change it. If it's oily, leave it out, hold a rag over the Plug hole and pull the Recoil Cord several times to blow out any oil in the Cylinder, then wipe off the Plug and reinsert it. ⇒ The Air Filter may be dirty, change it following the procedure in the Engine Owner's Manual. ⇒ If your Engine still won't start, call 1-800-DR-OWNER (376-9637) for assistance.

! WARNING!

WHEN PERFORMING ANY MAINTENANCE, YOU MUST FIRST SHUT OFF THE ENGINE, WAIT FIVE (5) MINUTES TO ALLOW PARTS TO COOL AND DISCONNECT THE SPARK PLUG WIRE, KEEPING IT AWAY FROM THE SPARK PLUG.

SYMPTOM	POSSIBLE CAUSE
<p><i>The Engine will not start using Electric-Start.</i></p> <p><i>(Please refer to the Engine Owner's Manual for Engine-specific procedures.)</i></p>	<ul style="list-style-type: none"> ⇒ Check all the items under the section called Electric-Starting on page 19. ⇒ Check the previous section (Manual Starting) for possible causes. ⇒ Check the wire connections—especially the ground connection, the large black wire coming from the Battery, where it connects to the Engine. ⇒ Check the wire connections to the Solenoid. Disconnect the black Battery ground wire first to avoid sparks. Check to be sure that all of the connections are clean and tight. Reconnect the Battery ground wire. ⇒ Check the ground connection on the Solenoid where it is bolted to the Frame. Using a wrench or socket, tighten the bolts to ensure a good connection to the Frame. ⇒ The Battery may not be charged. Check the voltage yourself or at a gas station. If it is low, charge it with a 12-volt, 1 to 2 Amp trickle charger. If you do not use your vacuum for at least 45 minutes at a time, the Battery may need to be periodically charged. See the Battery Care section on page 32. ⇒ If your Battery is charged and your DR WALK-BEHIND LEAF & LAWN VACUUM still will not start, call 1-800-DR-OWNER (376-9637) for assistance.
<p><i>The Engine lacks power or is not running smoothly.</i></p> <p><i>(Please refer to the Engine Owner's Manual for Engine-specific procedures.)</i></p>	<ul style="list-style-type: none"> ⇒ Check the Throttle to make sure it is set in the FAST position. ⇒ The Air Filter may be dirty, change it following the procedure in the Engine Owner's Manual. ⇒ The Spark Plug may be dirty or cracked, change it. If it's oily, leave it out, hold a rag over the Plug hole and pull the Recoil Cord several times to blow out any oil in the Cylinder, then wipe off the Plug and reinsert it. ⇒ The gas may be old, change it. Use a fuel stabilizer if you keep gas longer than one month. ⇒ The Engine may not have the right amount of clean oil. If it is dirty, change it following the procedure on page 31. ⇒ If your Engine still lacks power, call 1-800-DR-OWNER (376-9637) for assistance.
<p><i>Engine smokes.</i></p>	<ul style="list-style-type: none"> ⇒ Check the oil level and adjust as needed. ⇒ You may be operating the machine on too great an incline. See page 23. ⇒ Check the Air Filter and clean or replace if needed. ⇒ You may be using the wrong oil—too light for the temperature. Refer to your Engine Owner's Manual for detailed information. ⇒ Clean the Engine Cooling Fins and the Carburetor Housing if they are dirty. ⇒ If the Engine still smokes, call 1-800-DR-OWNER (376-9637) for assistance.

! WARNING!

WHEN PERFORMING ANY MAINTENANCE, YOU MUST FIRST SHUT OFF THE ENGINE, WAIT FIVE (5) MINUTES TO ALLOW PARTS TO COOL AND DISCONNECT THE SPARK PLUG WIRE, KEEPING IT AWAY FROM THE SPARK PLUG.

SYMPTOM	POSSIBLE CAUSE
<i>Will not vacuum or has poor vacuum performance.</i>	<ul style="list-style-type: none"> ⇒ The Debris Bag is full or dirty. See page 24. ⇒ Be sure the Engine Throttle is set on the fast (RABBIT) position. ⇒ The Nozzle height is set too high or too low. See page 20. ⇒ The Hose Kit Cap is missing on the Nozzle Door. ⇒ The Nozzle or Impeller Housing is clogged. ⇒ Excessive amount of debris being vacuumed; take smaller amounts at a time allowing air to feed with the debris. Use 1st or 2nd gear for best results. ⇒ If your DR WALK-BEHIND LEAF & LAWN VACUUM is still not vacuuming properly, call 1-800-DR-OWNER (376-9637) for assistance.
<i>Vibrations higher than normal.</i>	<ul style="list-style-type: none"> ⇒ The Impeller is loose or out of balance. Tighten or replace the Impeller. See page 33. ⇒ The Engine Mounting Bolts are loose. Tighten the Engine Mounting Bolts. See Figure 20 on page 33. ⇒ If your vacuum still exhibits abnormal vibrations, call 1-800-DR-OWNER (376-9637) for assistance.
<i>No Self-Propelling action.</i>	<ul style="list-style-type: none"> ⇒ The Transmission is not in gear. See Figure 12 on page 22. ⇒ The Drive Clutch is not engaged. Pull the Drive Clutch Lever up against the Handlebar. ⇒ The Drive Clutch Cable is out of adjustment or broken. Adjust or replace the Drive Clutch Cable. See page 35. ⇒ The Drive Belt is worn or broken. See page 36. ⇒ The Drive Chain is off the Sprocket. See page 37. ⇒ If your DR WALK-BEHIND LEAF & LAWN VACUUM still exhibits no Self-Propelling action, call 1-800-DR-OWNER (376-9637) for assistance.
<i>The Self-Propelled Drive will not release.</i>	<ul style="list-style-type: none"> ⇒ Improper Drive Clutch Cable adjustment or there is a kink in the Cable. See page 35. ⇒ The Drive Clutch Cable needs lubrication. Lubricate the control cables more frequently in dusty environments. ⇒ If the Self-Propelled action of your DR WALK-BEHIND LEAF & LAWN VACUUM still will not release, call 1-800-DR-OWNER (376-9637) for assistance.
<i>Noisy Drive Chain.</i>	<ul style="list-style-type: none"> ⇒ The Drive Chain needs lubrication. See page 30. ⇒ The Drive Chain is out of adjustment. See page 37.

PARTS LISTS, SCHEMATIC DIAGRAMS AND WARRANTY
Parts List - Nozzle and Front Axle Assembly

NOTE: Part numbers listed are available through Country Home Products, Inc.

Ref#	Part#	Description	Ref#	Part#	Description
01	21938	Yoke 1/2"-20	21	21803	Bolt, 1/4"-20 x 3/4", HWH
02	21877	Pin, Yoke 1/2"	22	21863	Link, Height Adjuster
03	21830	Bolt, Carriage, 3/8"-16 x 1-1/2", ZP	23	21820	Bracket, Nozzle, Wear Guard
04	21926	Washer, Flat, 3/8", SAE, ZP	24	21886	Rod, Connect, Height Adjuster
05	21868	Nut, Lock, Nylon, 3/8"-16, Thin, ZP	25	21827	Bushing, 0.5" ID x 0.625" OD x 0.250"
06	21902	Screw, Cap, 5/16"-18 x 3-1/2"	26	21888	Rod, Handle, Crank
07	21875	Nut, Lock, Nylon, 5/16"-18, UNC	27	21841	Handle, Crank, 0.5" ID x 3.72" Long
08	21931	Washer, Flat, Fender, 5/16"	28	21828	Bushing, 3/8" ID x 1/2" OD x 3/8" long
09	21871	Nut, Lock, Nylon, 1/2"-13, UNC Thin	29	21932	Washer, Lock, Twisted Tooth, 1/4"
10	21932	Washer, 1/4", FC, ZP	30	21869	Nut, Pal, 1/2" Diameter
11	21862	Label, Warning, Open	31	21865	Cover, Nozzle
12	21813	Bolt, Carriage, 5/16"-18 x 3-1/2"	32	21181	Label, Product Decal, DR
13	21890	Roll Pin, 1/4" x 1" long	33	21892	Screw, Plastic
14	21930	Washer, 1/2", SAE	34	21857	Label, Height Adjuster
15	21864	Nozzle, Vacuum, 27", Plastic	35	21893	Screw, Drill Point, 1/4" x 1"
16	21829	Cap, 5", Vacuum Hose	36	21818	Bracket, Nozzle, Cover Reinforcement
17	21842	Handle, Lower, Vacuum	37	21811	Bolt, Carriage, 1/4"-20 x 3/4"
18	21936	Wheel, 14", Assy w/Bearing & Tire	38	21867	Nut, Flange, 1/4"-20
19	21805	Axle, Front			
20	21817	Bracket, Height			

Schematic Diagram - Nozzle and Front Axle Assembly

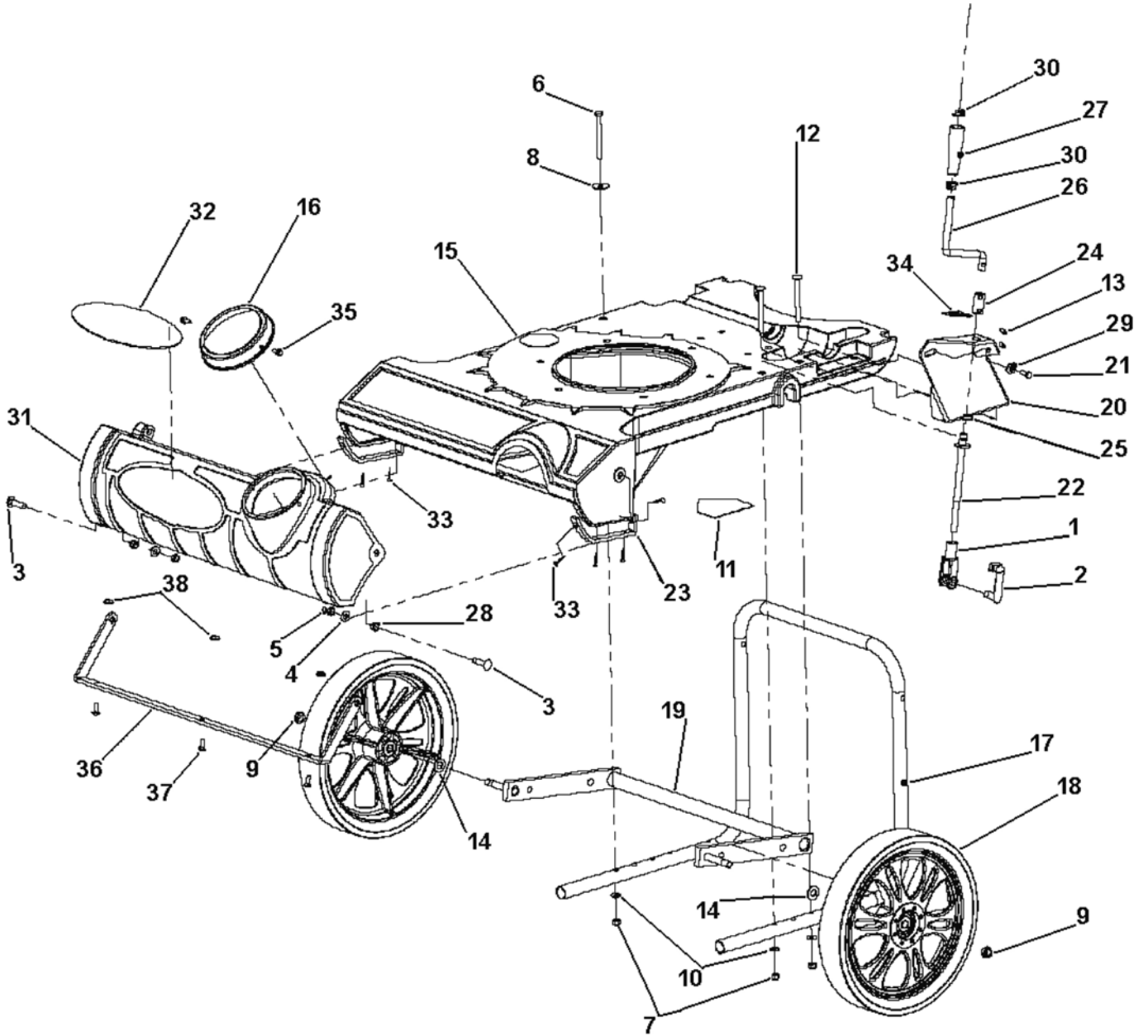

060928

Parts List - Drive/Rear Axle Assembly

NOTE: Part numbers listed are available through Country Home Products, Inc.

<u>Ref#</u>	<u>Part#</u>	<u>Description</u>	<u>Ref#</u>	<u>Part#</u>	<u>Description</u>
80	21825	Bracket, Transmission Mount	107	21893	Screw, Drill Point, 1/4" x 1"
81	21809	Bearing, 3/4" w/Pillow Block	108	21831	Chain, #41 x 42 Pitch
82	21836	Differential, 54 Tooth D-Cut	109	21911	Spring, Tension
83	21824	Bracket, Trans., Anti Rotation	110	21923	Washer, 1/4", FC, ZP
84	21840	Guard, Drive	111	21925	Washer, 3/4", SAE
85	21917	Trans., 3-Speed	112	21937	Key, Woodruff, 1/8" x 1/2"
86	21912	Sprocket, 8 Tooth	113	21832	Clip, 1/2"
87	21789	Belt, 3L34	114	21834	Control, Shift, Wescon
88	21808	Bearing, 1/2" Clip	115	21833	Control Lever Assy, Clutch
89	21882	Plate, Trans., Bearing Mount	116	21930	Washer, Flat, 1/2", SAE
90	21943	Washer, Lock, Internal Tooth, 1/2"	117	21898	Screw, Cap, 1/4"-20 x 4", HCS, ZP
91	21894	Screw, Socket Head, 1/4"-20 x 3/4"	118	21855	Label, Danger, Guard
92	21928	Washer, 5/16" Lock, Twisted Tooth	119	21868	Nut, Lock, 3/8"-16, LT. WT. Thin, ZP
93	21935	Wheel, 14" Assembly Drive	120	21853	Label, Clutch Drive
94	21811	Bolt, Carriage 1/4"-20 x 1"	121	21816	Bracket, Bearing
95	21826	Bracket, Trans., Reinforce	122	22266	Screw, Cap, 5/16"-18 x 3-1/2", HCS, ZP
96	21830	Bolt, Carriage 3/8"-20 x 1-1/2"	<u>The following are applicable to the Push model only:</u>		
97	21885	Pulley, Idler, 2" OD x 3/8" ID	200	21930	Washer, Flat, 1/2", SAE
98	21918	Tube, 3/4" ID, Wheel Spacer	201	21812	Bolt, Carriage, 5/16"-18 x 2-1/2"
99	21932	Washer, 1/4" Lock, Twisted Tooth	202	21923	Washer, 1/4", FC, ZP
100	21924	Washer, 1/4", SAE, ZP	203	21875	Nut, Lock, Nylon Insert, 5/16"-18, UNC
101	21872	Nut, Lock, Nylon Insert, 1/4"-20	204	21871	Nut, Lock, Nylon Insert, 1/2"-13 UNC
102	21905	Screw, Cap, 5/16"-18 x 3", HCS, ZP	205	21908	Shaft, Rear Axle
103	21875	Nut, Lock, Nylon Insert, 5/16"-18	206	21821	Bracket, Mount, Rear Axle
104	21904	Screw, Cap, 5/16"-18 x 3/4", ZP	207	21936	Wheel, 14", w/Bearing and Tire
105	21926	Washer, 3/8", SAE, ZP			
106	21804	Bolt, 1/4"-20 x 5/8", GR5			

Schematic Diagram - Drive/Rear Axle Assembly

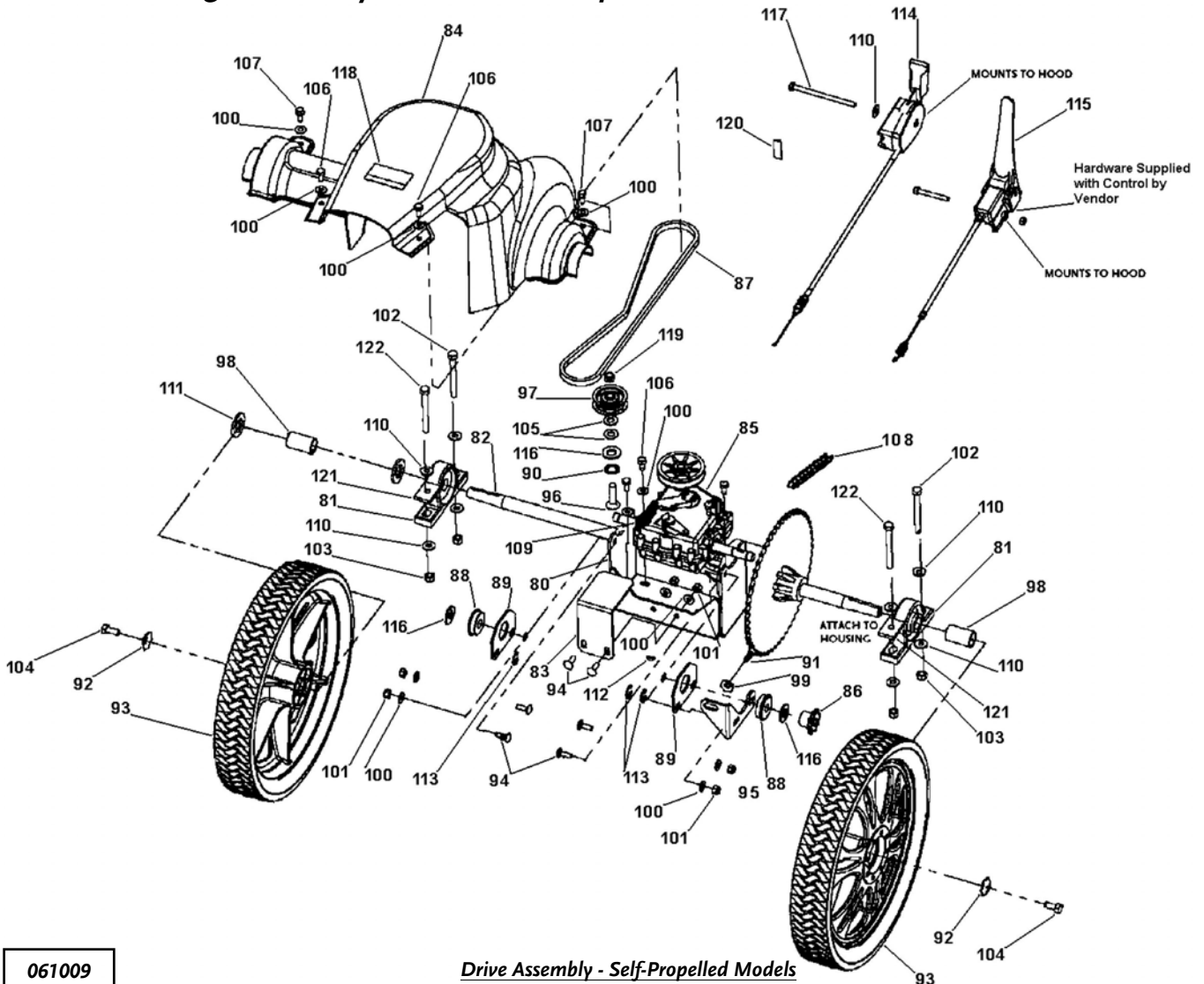

061009

Drive Assembly - Self-Propelled Models

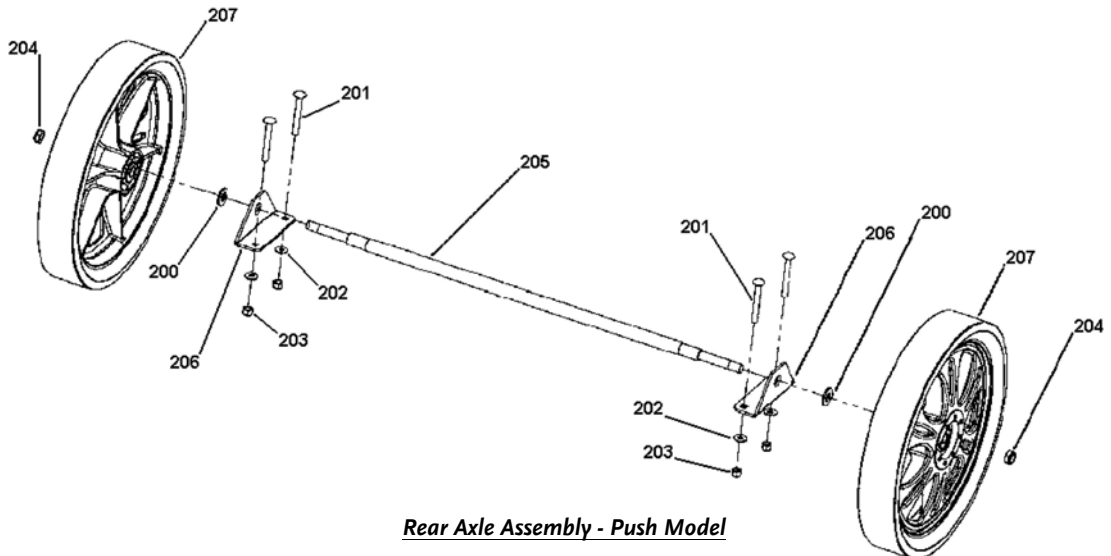

060928

Rear Axle Assembly - Push Model

Parts List - Engine w/Impeller and Housing - Manual-Start Model

NOTE: Part numbers listed are available through Country Home Products, Inc.

Ref#	Part#	Description
50	22413	Engine, Briggs & Stratton Quantum, M/S
	22352	Engine, Briggs & Stratton Quantum, M/S, CA
51	21851	Impeller Assembly, Self-Propelled models
	21852	Impeller Assembly, Push model
52	21881	Plate, Top, Self-Propelled models
	21880	Plate, Top, Push model
53	21850	Housing, Plastic
54	21933	Washer, Lock, 3/8", Twisted Tooth
55	21858	Label, Hot Engine
56	21913	Key, Square, 2.125" x .187"
57	21835	Control, Throttle
58	21872	Nut, Lock, Nylon Insert, 1/4"-20, UNC
59	21924	Washer, 1/4", SAE, ZP
60	21929	Washer, Fender, 1/4" ZP
61	21803	Bolt, 1/4"-20 x 3/4", HWH
62	21901	Screw, Cap, 3/8"-24 x 2-3/4" w/Patch Lock
63	21899	Screw, Cap, 3/8"-16 x 2-1/2", Taptite
64	21804	Bolt, 1/4"-20 x 5/8", GR5
65	21898	Screw, Cap, 1/4"-20 x 4", HCS, ZP
66	21923	Washer, 1/4", FC, ZP
67	22267	Washer, 1/4" Lock, Twisted Tooth

Schematic Diagram - Engine w/Impeller and Housing - Manual-Start Model

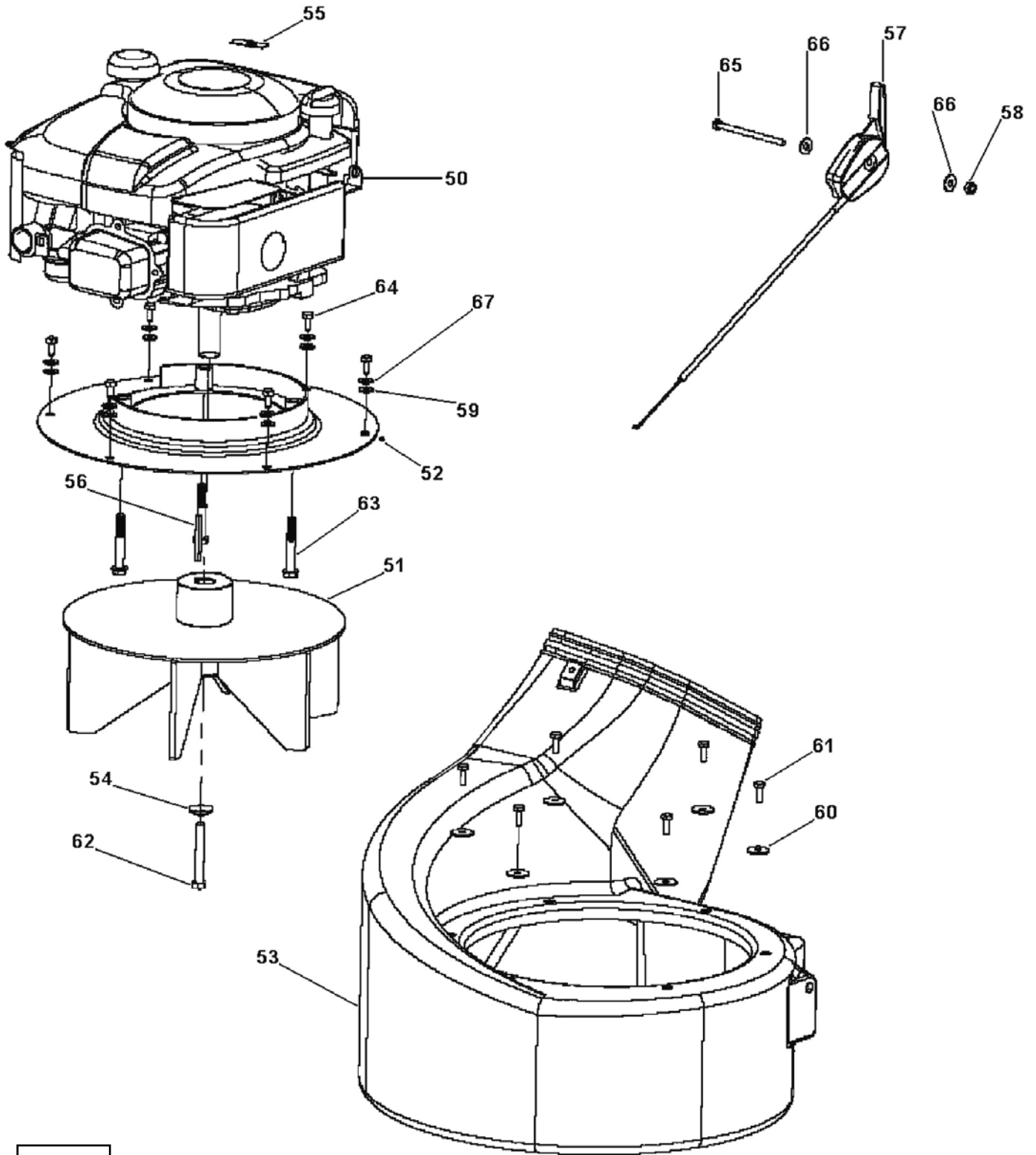

070809

Parts List - Engine w/Impeller and Housing - Electric-Start Model

NOTE: Part numbers listed are available through Country Home Products, Inc.

Ref#	Part#	Description
50	22414	Engine, Briggs & Stratton Quantum, E/S
	22353	Engine, Briggs & Stratton Quantum, E/S, CA
51	21851	Impeller Assembly
52	21881	Plate, Top
53	21850	Housing, Plastic
54	21933	Washer, Lock, 3/8", Twisted Tooth
55	21858	Label, Hot Engine
56	21913	Key, Square, 2.125" x .187"
57	21835	Control, Throttle
58	22582	Nut, 1/4"-20, UNC
59	21924	Washer, 1/4", SAE, ZP
60	21929	Washer, Fender, 1/4" ZP
61	21803	Bolt, 1/4"-20 x 3/4", HWH
62	21901	Screw, Cap, 3/8"-24 x 2-3/4" w/Patch Lock
63	21899	Screw, Cap, 3/8"-16 x 2-1/2", Taptite
64	21804	Bolt, 1/4"-20 x 5/8", GR5
65	21898	Screw, Cap, 1/4"-20 x 4", HCS, ZP
66	21923	Washer, 1/4", FC, ZP
68	21914	Switch, Ignition
69	21823	Bracket, Starter Switch
70	21909	Solenoid, Electric Start
71	13510	Hold Down, Battery
72	21845	Harness, Cable, Electric Start
73	21844	Harness, Cable, Battery
74	21846	Harness, Cable, Ground
75	21897	Screw, Cap, 1/4"-20 x 1", HCS, ZP
76	13119	Battery, 12V - 5.6 AH
77	21861	Label, Start/Stop, Toggle
78	21822	Bracket, Mount, Solenoid
79	21893	Screw, Drill Point, 1/4" x 1"
80	22267	Washer, 1/4" Lock, Twisted Tooth
191	22583	Washer, Lock, External Tooth, 1/4"

Schematic Diagram - Engine w/Impeller and Housing - Electric-Start Model

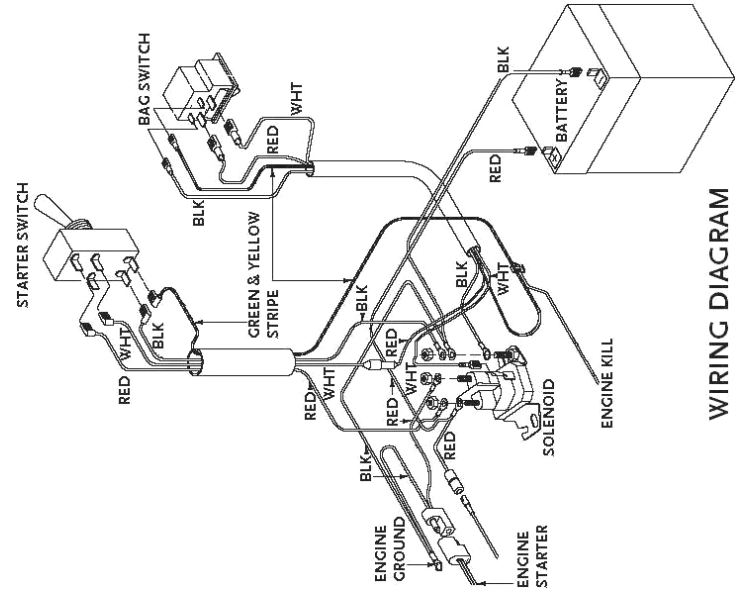
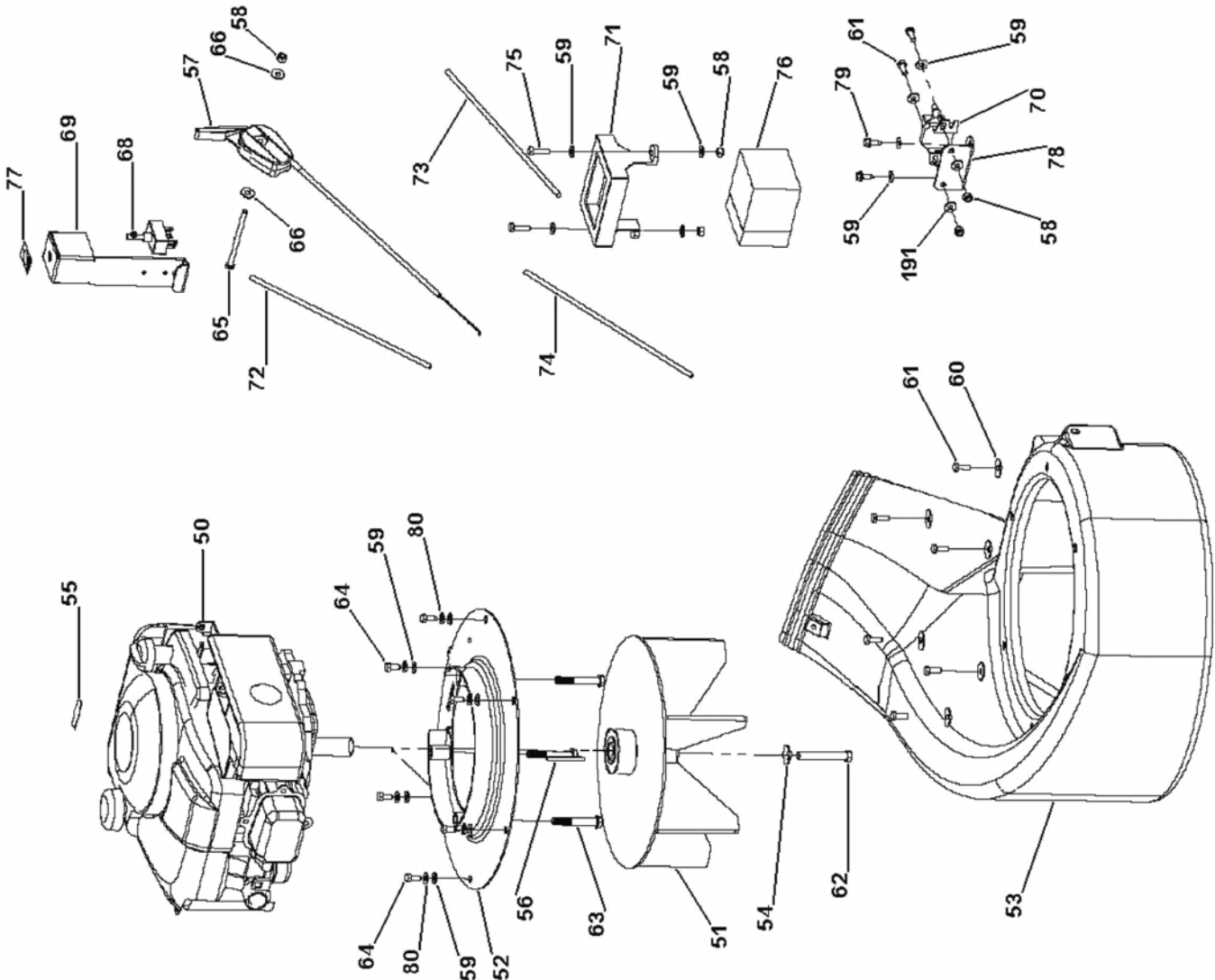

070809

Schematic Diagram - Top Shield, Bag Assembly and Controls - All Models

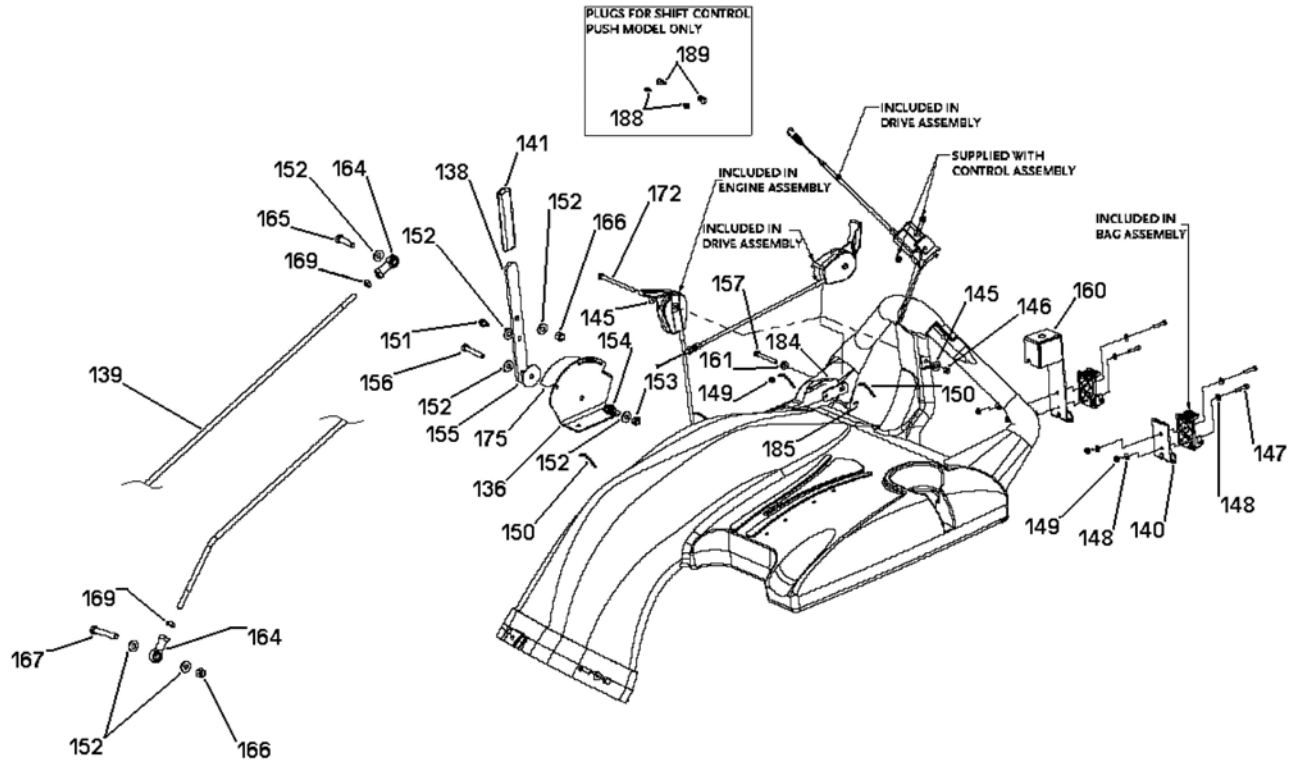

061009

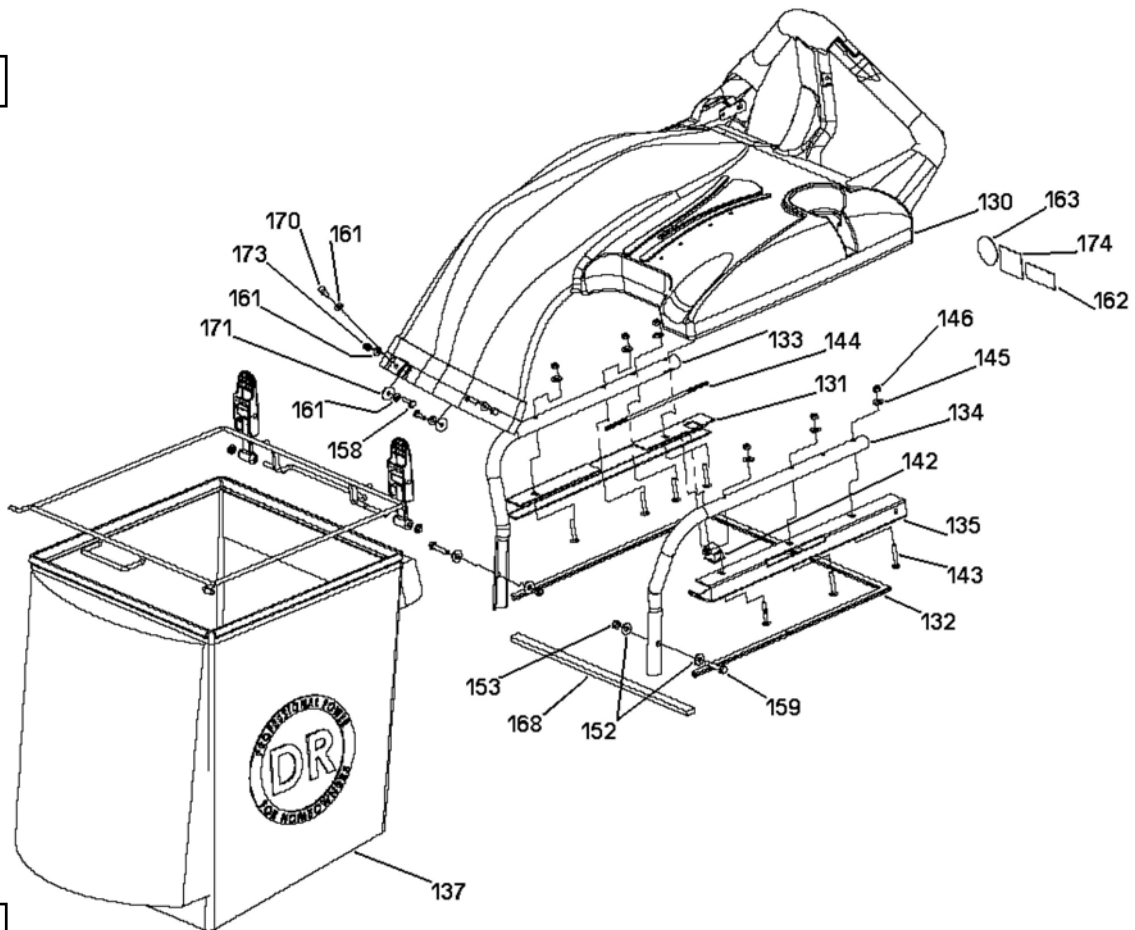

060928

Notes:



DR[®] WALK-BEHIND LEAF & LAWN VACUUM

2-Year Limited Warranty

Terms and Conditions

The DR[®] WALK-BEHIND LEAF & LAWN VACUUM is warranted for two (2) years against defects in materials or workmanship when put to ordinary and normal consumer use; ninety (90) days for any other use. The engine manufacturer warrants the engine separately.

For the purposes of all the above warranties, "ordinary and normal consumer use" refers to non-commercial residential use and does not include misuse, accidents, or damage due to inadequate maintenance.

Country Home Products, Inc. (home of DR[®] Power Equipment) certifies that the DR[®] WALK-BEHIND LEAF & LAWN VACUUM is fit for ordinary purposes for which a product of this type is used. Country Home Products, Inc. however, limits the implied warranties of merchantability and fitness in duration to a period of two (2) years in consumer use, ninety (90) days for any other use.

The 2-Year Limited Warranty on the DR[®] WALK-BEHIND LEAF & LAWN VACUUM starts on the date the machine ships from our factory. The 2-Year Limited Warranty is applicable only to the original owner.

The warranty holder is responsible for the performance of the required maintenance as defined by the manufacturer's owner manuals. The warranty holder is responsible for replacement of normally wearing parts such as the Drive Belt, Debris Bag, Battery, and Spark Plug. Attachments and accessories to the machine are not covered by this warranty.

During the warranty period, the warranty holder is responsible for the machine transportation charges, if required. During the warranty period, warranty parts will ship by standard method at no charge to the warranty holder. Expedited shipping of warranty parts is the responsibility of the warranty holder.

SOME STATES DO NOT ALLOW LIMITATIONS ON THE LENGTH OF IMPLIED WARRANTIES, SO THE ABOVE LIMITATIONS MAY NOT APPLY TO YOU.

Country Home Products, Inc. shall not be liable under any circumstances for any **incidental or consequential damages or expenses** of any kind, including, but not limited to, cost of equipment rentals, loss of profit, or cost of hiring services to perform tasks normally performed by the DR[®] WALK-BEHIND LEAF & LAWN VACUUM.

SOME STATES DO NOT ALLOW THE EXCLUSION OR LIMITATION OF INCIDENTAL OR CONSEQUENTIAL DAMAGES, SO THE ABOVE LIMITATIONS MAY NOT APPLY TO YOU.

Customer Service Hotline

Country Home Products, Inc.'s objective is to have 100% satisfied customers. For that reason, we operate a 6-day-a-week Technical Service Department for our Owners. You can access a Representative by dialing our **TOLL-FREE Hotline at 1-800-DR-OWNER (376-9637)**. The sole job of our well-trained and friendly folks is to ensure that you get any help you need in a timely fashion. They are there to answer all your questions including: (1) inquiries on any of the above warranties, (2) inquiries about replacement parts, or (3) your questions regarding service, maintenance, and operation.

Our Customer Service Representatives will also be happy to answer any of your questions regarding the separate warranties on all Engines. However, to obtain service, repair, or replacement of any Engine within the period covered by the manufacturer's limited warranty, follow the instructions and warranty information specifically pertaining to those items provided by their separate manufacturers.

THIS WARRANTY GIVES YOU SPECIFIC LEGAL RIGHTS, AND YOU HAVE OTHER RIGHTS, WHICH VARY FROM STATE TO STATE.

Daily Checklist for the DR WALK-BEHIND LEAF & LAWN VACUUM

To help maintain your DR WALK-BEHIND LEAF & LAWN VACUUM for optimum performance, we recommend you follow this checklist each time you use your machine.

- [] OIL: With the machine on a level surface, remove the oil fill cap and check the oil level. Fill the reservoir according to the dipstick with SAE 30 HD motor oil. See page 15.
- [] GAS: Fill the gas tank with fresh, unleaded gasoline. See page 15.
- [] ENGINE: It is very important to keep the engine clean. Remove dirt and other debris from the engine cooling fins and debris guard. A dirty engine retains heat and can cause damage to internal engine components.
- [] HARDWARE: Check all nuts and bolts to be sure that the components are secure.
- [] FRAME: Check all welds to be sure that the frame is intact and secure.
- [] DEBRIS BAG: Make sure that the Debris Bag is securely fastened to the Top Shield Assembly and the Bag Presence Interlock Switch is engaged. See page 25.
- [] NOZZLE and IMPELLER: Make sure that the Nozzle and Impeller are free of accumulated debris



DR® Power Equipment, A division of Country Home Products®

127 MEIGS ROAD, P.O. BOX 25, VERGENNES, VERMONT 05491

1-800-DR-OWNER (376-9637) • www.dr-owner.com

©2007 CHP, Inc. 223771A