

DR[®] TRIMMER/MOWER™



SAFETY & OPERATING INSTRUCTIONS

Models: SPRINT[®], PRO, COMMERCIAL and SELF- PROPELLED



WARNING!

READ AND UNDERSTAND THIS MANUAL AND ALL INSTRUCTIONS BEFORE OPERATING THIS TRIMMER/MOWER.

THANK YOU!

Congratulations on your purchase of a new DR TRIMMER/MOWER!

We have done our utmost to ensure that your DR TRIMMER/MOWER will be one of the most trouble-free and satisfying pieces of equipment you have ever owned. Please let us know of any questions you may have. We want to answer or correct them as quickly as possible. When you do call, please have your serial number and/or order number handy. **For technical assistance, please call Toll-Free 1-800-DR-OWNER (376-9637) and one of our Technical Support Representatives will be happy to help you.** We also hope to hear from you on how much you like your new helper.

In addition, please tell your friends about your new DR TRIMMER/MOWER! Having owners spread the word about our products and our way of doing business is the best advertising we can have, and the best way to help us provide even better service in the years to come.

Thanks once again!



for all of us at
COUNTRY HOME PRODUCTS, INC.®

SALES MANAGER

COPYRIGHT

©2007 Country Home Products, Inc. All rights reserved.



DR® Power Equipment
A division of Country Home Products®
127 Meigs Road
Vergennes, VT 05491

Toll-Free phone: 1-800-DR-OWNER (376-9637)

Fax: 1-802-877-1213

Web site: www.dr-owner.com

Table of Contents

CHAPTER 1	1
INTRODUCING THE DR TRIMMER/MOWER	1
Conventions used in this manual	1
CHAPTER 2	3
GENERAL SAFETY RULES.....	3
Labels	3
Protecting Yourself and Those Around You	5
Safety for Children and Pets	6
Safety with Gasoline - Powered Engines	6
General Safety	7
A Note to All Users	8
Additional Information and Potential Changes	8
CHAPTER 3	9
SETTING UP YOUR DR TRIMMER/MOWER.....	9
DR TRIMMER/MOWER Controls and Features	10
Unpacking the DR TRIMMER/MOWER.....	11
Adding the Engine Oil and Gasoline.....	12
Connecting the Battery Wire (Electric-Starting Models Only)	13
Adjusting the Handlebar	14
Adjusting the PTA™ (Parallel Trimming Action) Lever – SPRINT®, PRO and COMMERCIAL.....	15
CHAPTER 4	17
OPERATING YOUR DR TRIMMER/MOWER.....	17
Before Starting the Engine.....	17
Electric-Starting.....	18
Manual-Starting	18
Stopping the Engine	18
Engaging the Trimmer Head.....	19
Stopping the Cords from Spinning	19
Engaging the Wheel Drive - SELF-PROPELLED model	19
Using the PTA™ (Parallel Trimming Action) - SPRINT®, PRO and COMMERCIAL models only	20
Engaging the PTA™	21
Returning to Normal Mode	21
The DR TRIMMER/MOWER Cutting Cords	22
Installing Cords.....	23
Cord Tips.....	24
Adjusting the Cutting Height	25
The Mow-Ball™ Support.....	25
Obstacle Tips	26
Heavy Growth	27
Wet Conditions	28
Very Dry Conditions.....	28
Slopes	28
Windrows	28
Firebreaks	28
Garden Clean-Up	28
CHAPTER 5	29
MAINTAINING THE DR TRIMMER/MOWER	29
Regular Maintenance Check List.....	29
Battery Care (Electric-Start Models).....	30
Charging the Battery	30

Removing the Mow-Ball™ Support Assembly.....	31
Reassembling the Mow-Ball™ Support Assembly.....	32
Removing the Stone Guard Flap - SPRINT®, PRO, and COMMERCIAL	33
Removing and Replacing Section:.....	33
Bottom Shield - SPRINT®, PRO, and COMMERCIAL	33
Bottom Shield - SELF-PROPELLED.....	34
Trimmer Head Belt – All models	35
Drive Belt - SELF-PROPELLED	36
Brake Arm – All models	37
Side Shield – All models.....	38
Wheels - SPRINT®, PRO and COMMERCIAL.....	38
Wheels - SELF-PROPELLED	39
Engine Oil – All models.....	40
Engine Oil Filter – COMMERCIAL and SELF-PROPELLED.....	41
Adjusting the Trimmer Head Belt Tension through the Trimmer Control Cable – All models.....	42
Adjusting the Wheel Clutch - SELF-PROPELLED.....	43
End of Season and Storage.....	44
 CHAPTER 6	 45
TROUBLESHOOTING.....	45
Troubleshooting Table.....	45
 CHAPTER 7	 50
PARTS LISTS, SCHEMATIC DIAGRAMS AND WARRANTY.....	50
Parts List - Handlebar Assembly - SPRINT®, PRO and COMMERCIAL	50
Schematic - Handlebar Assembly - SPRINT®, PRO and COMMERCIAL.....	51
Parts List - Axle Assembly - SPRINT®, PRO and COMMERCIAL	52
Schematic - Axle Assembly - SPRINT®, PRO and COMMERCIAL	53
Parts List - Main Frame Assembly - All Models.....	54
Schematic - Main Frame Assembly - All Models	55
Parts List - Handlebar Assembly - SELF- PROPELLED.....	56
Schematic - Handlebar Assembly - SELF- PROPELLED	57
Parts List - Axle Assembly - SELF-PROPELLED	58
Schematic - Axle Assembly - SELF-PROPELLED.....	59
Parts List - Mow Ball™ Assembly - All Models	60
Schematic - Mow Ball™ Assembly - All Models.....	61
Notes	62
Warranty	63

INTRODUCING THE DR TRIMMER/MOWER

This manual will help you set up and safely operate your new DR TRIMMER/MOWER. Careful adherence to the safety and operating instructions in this manual will ensure many years of productive use.

Please let us know of any questions you may have. We want to answer them as quickly as possible. When you do call, please have your serial number and/or order number handy. **For technical assistance, please call Toll-Free 1-800-DR-OWNER (376-9637) and one of our Technical Support Representatives will be happy to help you.**

Conventions used in this manual

WARNING!

THIS INDICATES A HAZARDOUS SITUATION, WHICH, IF NOT AVOIDED, COULD RESULT IN DEATH OR SERIOUS INJURY.

CAUTION!

THIS INDICATES A HAZARDOUS SITUATION, WHICH, IF NOT AVOIDED, COULD RESULT IN MINOR OR MODERATE INJURY.

NOTICE!

THIS INFORMATION IS IMPORTANT IN THE PROPER USE OF YOUR MACHINE. FAILURE TO FOLLOW THIS INSTRUCTION COULD RESULT IN DAMAGE TO YOUR MACHINE OR PROPERTY.

Tip: This is a helpful hint to guide you in getting the most out of your DR TRIMMER/MOWER.

Tools Needed: This indicates you will need a special tool to perform a maintenance function on your Trimmer/Mower.

NOTE: *This information may be helpful to you.*

If you are ever unsure about an action you are about to take, don't do it, contact Country Home Products' Toll-Free support at 1-800-DR-OWNER (376-9637) for help or information.

GENERAL SAFETY RULES





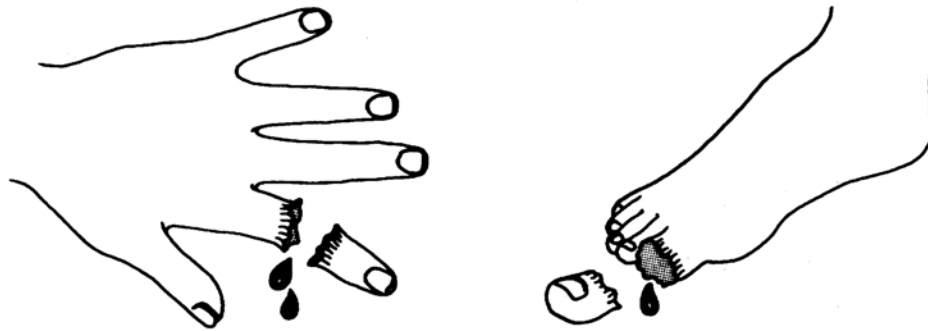

WARNING!

- READ THIS SAFETY & OPERATING INSTRUCTIONS MANUAL BEFORE YOU USE THE DR TRIMMER/MOWER. BECOME FAMILIAR WITH THE OPERATION AND SERVICE RECOMMENDATIONS TO ENSURE THE BEST PERFORMANCE FROM YOUR MACHINE.
- THOROUGHLY INSPECT THE AREA IN WHICH YOU WILL BE WORKING AND REMOVE ALL FOREIGN OBJECTS. THE SITE MUST BE FREE OF POTENTIALLY HAZARDOUS OBSTACLES (E.G., STONES, LOGS, STICKS, ROPE, WIRE, GARDEN TOOLS, GLASS AND METAL OBJECTS SUCH AS CANS). MOWING OVER THESE OBJECTS COULD DAMAGE THE MACHINE AND CAUSE INJURY.
- THIS IS A HIGH-POWERED MACHINE, WITH MOVING PARTS OPERATING WITH HIGH ENERGY AT HIGH SPEEDS. YOU MUST USE PROPER CLOTHING AND SAFETY GEAR WHEN OPERATING THIS MACHINE TO PREVENT OR MINIMIZE THE RISK OF SEVERE INJURY. THIS MACHINE CAN CUT; AND SEVER PARTS OF YOUR BODY IF THEY ENCOUNTER THE SPINNING CORDS.



Labels

Your DR TRIMMER/MOWER carries prominent labels as reminders for its proper and safe use. Shown below are copies of all the labels that appear on the equipment. Take a moment to study them and make a note of their location on your DR TRIMMER/MOWER as you assemble and *before* you operate the unit. Replace damaged or missing safety and information labels immediately.

	Read the Safety and Operating Instructions.		Always wear safety glasses or goggles while operating the machine.
	Do not operate the machine near people or animals.		Keep body parts away from the trimmer line.
	Remove all objects that could be thrown by the Trimmer Cord.		Use caution operating the machine on slopes.

(#14823)

WARNING: Add Oil Before Starting Engine

Make sure you add oil before starting the engine; the unit shipped without oil. Fill the oil reservoir slowly to make sure you do not overfill it. (#12781)



To avoid injury, keep your hands and feet away from the spinning cords. (#13649)



This is a warning about the danger inherent in the spinning cords. (#14822)

PTA[®] PARALLEL TRIMMING ACTION
215001

In the PTA[™] (Parallel Trimming Action) mode, the trimmer's wheels stay straight while the trimmer head tilts, causing the cords to extend beyond the wheelbase. (#215001)

BAIL BAR
Release to Stop Cords Spinning

The bail bar is an important safety feature. Release it to immediately stop the cords from spinning. (#15308)

TRIMMER/MOWER[™]
COUNTRY HOME PRODUCTS[®]
Vergennes, VT 05491
1-800-DR-DOWNER (376-9637)
www.countryhomeproducts.com
148241

This notice is a handy reminder of your equipment's name and how you can contact us. (#14824)



#179401

Protecting Yourself and Those Around You

WARNING!

THIS IS A HIGH-POWERED MACHINE, WITH MOVING PARTS OPERATING WITH HIGH ENERGY AT HIGH SPEEDS. YOU MUST OPERATE THE MACHINE SAFELY. UNSAFE OPERATION CAN CREATE A NUMBER OF HAZARDS FOR YOU, AS WELL AS ANYONE ELSE IN THE NEARBY AREA. ALWAYS TAKE THE FOLLOWING PRECAUTIONS WHEN USING THIS MACHINE:

- ALWAYS WEAR PROTECTIVE GOGGLES OR SAFETY GLASSES WITH SIDE SHIELDS WHILE MOWING TO PROTECT YOUR EYES FROM POSSIBLE THROWN DEBRIS. GOGGLES ARE PROVIDED WITH YOUR DR TRIMMER/MOWER.
- AVOID WEARING LOOSE CLOTHING OR JEWELRY, WHICH CAN CATCH ON THE MOWER'S MOVING PARTS.
- WE RECOMMEND WEARING GLOVES WHILE MOWING. BE SURE YOUR GLOVES FIT PROPERLY AND DO NOT HAVE LOOSE CUFFS OR DRAWSTRINGS.
- WEAR SHOES WITH NON-SLIP TREADS WHEN USING YOUR DR TRIMMER/MOWER. IF YOU HAVE SAFETY SHOES, WE RECOMMEND WEARING THEM. DO NOT USE THE MACHINE WHILE BAREFOOT OR WEARING OPEN SANDALS.
- WEAR LONG PANTS WHILE OPERATING THE DR TRIMMER/MOWER.
- USE EAR PROTECTORS OR EAR PLUGS RATED FOR AT LEAST 20 DBA TO PROTECT YOUR HEARING.
- NEVER ALLOW PEOPLE WHO ARE UNFAMILIAR WITH THESE INSTRUCTIONS TO USE THE DR TRIMMER/MOWER. ALLOW ONLY RESPONSIBLE INDIVIDUALS WHO ARE FAMILIAR WITH THESE RULES OF SAFE OPERATION TO USE YOUR MACHINE.
- NEVER PLACE YOUR HANDS, FEET, OR ANY PART OF YOUR BODY ON OR UNDER THE MOWER DECK IN THE PATH OF THE SPINNING CORDS, BELT, PULLEYS, OR NEAR THE DISCHARGE OPENING WHILE THE ENGINE IS RUNNING. KEEP AREA OF DISCHARGE CLEAR OF PEOPLE, ANIMALS, BUILDINGS, GLASS, OR ANYTHING ELSE THAT WILL OBSTRUCT CLEAR DISCHARGE, CAUSE INJURY, OR DAMAGE.
- KEEP BYSTANDERS AT LEAST 50 FEET AWAY FROM YOUR WORK AREA AT ALL TIMES. THE TIPS OF THE CUTTING CORDS ON THE DR TRIMMER/MOWER CAN THROW STICKS, SMALL STONES, GRAVEL, AND BITS OF DEBRIS OVER LONG DISTANCES AT GREAT VELOCITY. DO NOT TRAVEL OVER LOOSE MATERIALS SUCH AS GRAVEL OR MULCH WITH THE TRIMMER HEAD SPINNING. DOING SO COULD CAUSE PERSONAL INJURY OR PROPERTY DAMAGE FROM THROWN OBJECTS. RELEASE THE BAIL BAR TO STOP THE SPINNING CORDS AND SHUT OFF THE ENGINE WHEN ANOTHER PERSON OR PET APPROACHES.
- TO BE SAFE, DO NOT OPERATE THE MACHINE NEAR SMALL CHILDREN OR PETS, AND NEVER ALLOW CHILDREN TO OPERATE THE DR TRIMMER/MOWER.
- DO NOT OPERATE THE ENGINE WITH THE AIR CLEANER OR COVER OVER THE CARBURETOR AIR-INTAKE REMOVED, EXCEPT FOR ADJUSTMENT. REMOVAL OF SUCH PARTS COULD CREATE A FIRE HAZARD. DO NOT USE FLAMMABLE SOLUTIONS TO CLEAN AIR FILTER.
- ALWAYS OPERATE THE MOWER FROM BEHIND THE HANDLEBAR. NEVER PASS OR STAND ON THE DISCHARGE SIDE OF THE MACHINE WHEN THE ENGINE IS RUNNING OR CUTTING CORDS ARE SPINNING.
- THE MUFFLER AND ENGINE BECOME VERY HOT AND CAN CAUSE A SEVERE BURN; DO NOT TOUCH.
- NEVER, UNDER ANY CONDITIONS, REMOVE, BEND, CUT, FIT, WELD, OR OTHERWISE ALTER STANDARD PARTS ON THE DR TRIMMER/MOWER. THIS INCLUDES ALL SHIELDS AND GUARDS. MODIFICATIONS TO YOUR MACHINE COULD CAUSE PERSONAL INJURIES AND PROPERTY DAMAGE AND WILL VOID YOUR WARRANTY.

Safety for Children and Pets

WARNING!

TRAGIC ACCIDENTS CAN OCCUR IF THE OPERATOR IS NOT ALERT TO THE PRESENCE OF CHILDREN AND PETS. CHILDREN ARE OFTEN ATTRACTED TO THE MACHINE AND THE MOWING ACTIVITY. *NEVER* ASSUME THAT CHILDREN WILL REMAIN WHERE YOU LAST SAW THEM. ALWAYS FOLLOW THESE PRECAUTIONS:

- KEEP CHILDREN AND PETS OUT OF THE WORKING AREA AND UNDER THE WATCHFUL CARE OF A RESPONSIBLE ADULT.
 - BE ALERT AND TURN THE MACHINE OFF IF CHILDREN OR PETS ENTER THE WORK AREA.
 - NEVER ALLOW CHILDREN TO OPERATE THE DR TRIMMER/MOWER.
-

Safety with Gasoline - Powered Engines

WARNING!

GASOLINE IS A HIGHLY FLAMMABLE LIQUID. GASOLINE ALSO GIVES OFF FLAMMABLE VAPOR THAT CAN BE EASILY IGNITED AND CAUSE A FIRE OR EXPLOSION. NEVER OVERLOOK THE HAZARDS OF GASOLINE. ALWAYS FOLLOW THESE PRECAUTIONS:

- NEVER RUN THE ENGINE IN AN ENCLOSED AREA OR WITHOUT PROPER VENTILATION AS THE EXHAUST FROM THE ENGINE CONTAINS CARBON MONOXIDE, WHICH IS AN ODORLESS, TASTELESS, AND DEADLY POISONOUS GAS.
 - STORE ALL FUEL AND OIL IN CONTAINERS SPECIFICALLY DESIGNED AND APPROVED FOR THIS PURPOSE AND KEEP AWAY FROM HEAT AND OPEN FLAME, AND OUT OF THE REACH OF CHILDREN.
 - FILL THE GASOLINE TANK OUTDOORS WITH THE ENGINE OFF AND ALLOW THE ENGINE TO COOL COMPLETELY. DO NOT HANDLE GASOLINE IF YOU OR ANYONE NEARBY IS SMOKING, OR IF YOU ARE NEAR ANYTHING THAT COULD CAUSE IT TO IGNITE OR EXPLODE. REINSTALL THE FUEL TANK AND FUEL CONTAINER CAPS SECURELY.
 - IF YOU SPILL GASOLINE, DO NOT ATTEMPT TO START THE ENGINE. MOVE THE MOWER AWAY FROM THE AREA OF THE SPILL AND AVOID CREATING ANY SOURCE OF IGNITION UNTIL THE GAS VAPORS HAVE DISSIPATED. WIPE UP ANY SPILLED FUEL TO PREVENT A FIRE HAZARD AND PROPERLY DISPOSE OF THE WASTE.
 - ALLOW THE ENGINE TO COOL COMPLETELY BEFORE STORING IN ANY ENCLOSURE. NEVER STORE THE MACHINE WITH GAS IN THE TANK OR A FUEL CONTAINER, NEAR AN OPEN FLAME OR SPARK SUCH AS A WATER HEATER, SPACE HEATER, CLOTHES DRYER OR FURNACE.
 - NEVER MAKE ADJUSTMENTS OR REPAIRS WITH THE ENGINE RUNNING. STOP THE ENGINE, WAIT FIVE (5) MINUTES TO MAKE CERTAIN ALL MOVING PARTS HAVE COME TO A COMPLETE STOP AND COOL. DISCONNECT THE SPARK PLUG WIRE, KEEPING IT AWAY FROM THE SPARK PLUG TO PREVENT ACCIDENTAL STARTING.
 - NEVER TAMPER WITH THE ENGINE'S GOVERNOR SETTING. THE GOVERNOR CONTROLS THE MAXIMUM SAFE OPERATING SPEED AND PROTECTS THE ENGINE. OVER-SPEEDING THE ENGINE IS DANGEROUS AND WILL CAUSE DAMAGE TO THE ENGINE AND TO THE OTHER MOVING PARTS OF THE MACHINE. IF REQUIRED, SEE YOUR AUTHORIZED ENGINE DEALER FOR ENGINE GOVERNOR ADJUSTMENTS.
 - TO REDUCE FIRE HAZARD, KEEP THE ENGINE AND MUFFLER FREE OF DEBRIS BUILD-UP.
-

General Safety

WARNING!

YOU MUST SAFELY OPERATE THE DR TRIMMER/MOWER TO PREVENT OR MINIMIZE THE RISK OF DEATH OR SERIOUS INJURY. UNSAFE OPERATION CAN CREATE A NUMBER OF HAZARDS FOR YOU. ALWAYS TAKE THE FOLLOWING PRECAUTIONS WHEN OPERATING THIS MOWER:

- KEEP IN MIND THAT THE OPERATOR OR USER IS RESPONSIBLE FOR ACCIDENTS OR HAZARDS OCCURRING TO OTHER PEOPLE, THEIR PROPERTY, AND THEMSELVES.
- YOUR DR TRIMMER/MOWER IS A POWERFUL TOOL, NOT A PLAYTHING. EXERCISE EXTREME CAUTION AT ALL TIMES. THE DESIGN OF YOUR MACHINE IS FOR TRIMMING AND MOWING GRASS, WEEDS, AND OTHER GROWTH AS SPECIFIED IN THIS MANUAL. DO NOT USE IT FOR ANY OTHER PURPOSE.
- KNOW HOW TO STOP THE MOWER QUICKLY; SEE PAGE 18.
- NEVER OPERATE YOUR UNIT ON A SLIPPERY, WET, OR MUDDY SURFACE. EXERCISE CAUTION TO AVOID SLIPPING OR FALLING.
- KEEP YOUR FACE AND BODY BACK FROM THE DISCHARGE AREA.
- BE CAUTIOUS WHEN USING YOUR DR TRIMMER/MOWER AROUND FENCING, WIRES, ROPES, AND HOSES. IT IS POSSIBLE THAT THESE AND OTHER DEBRIS CAN BECOME WOUND AROUND THE LINE PLATES OF THE MACHINE, POTENTIALLY DAMAGING THE BEARINGS OR INJURING YOU.
- WHENEVER YOU LEAVE THE OPERATING POSITION TO MAKE ADJUSTMENTS, CHANGE CORDS OR IF YOU HAVE TO REMOVE GRASS OR DEBRIS FROM THE UNDERSIDE OF THE DECK, ALWAYS SHUT OFF THE ENGINE AND WAIT FIVE (5) MINUTES TO MAKE CERTAIN ALL MOVING PARTS HAVE COME TO A COMPLETE STOP AND COOL. REMOVE THE KEY, IF SO EQUIPPED, AND DISCONNECT THE SPARK PLUG WIRE AND KEEP THE WIRE AWAY FROM THE SPARK PLUG TO PREVENT ACCIDENTAL STARTING.
- THE EXHAUST AREA ON THE ENGINE BECOMES VERY HOT WITH USE. ALLOW THE ENGINE TO COOL BEFORE REFUELING, DOING MAINTENANCE, OR MAKING ADJUSTMENTS.
- KEEP COMBUSTIBLE SUBSTANCES AWAY FROM THE ENGINE WHEN IT IS HOT.
- NEVER COVER THE MACHINE WHILE THE MUFFLER IS STILL HOT.
- SEE MANUFACTURE'S INSTRUCTIONS FOR PROPER OPERATION AND INSTALLATION OF ACCESSORIES. ONLY USE ACCESSORIES APPROVED BY COUNTRY HOME PRODUCTS, INC.
- IF THE CUTTING CORDS STRIKE A FOREIGN OBJECT OR IF YOUR MACHINE SHOULD START MAKING AN UNUSUAL NOISE OR VIBRATION, STOP THE ENGINE AND WAIT FIVE (5) MINUTES FOR ALL MOVING PARTS TO COME TO A COMPLETE STOP AND COOL. VIBRATION IS GENERALLY A WARNING OF TROUBLE. DISCONNECT THE SPARK PLUG WIRE AND INSPECT FOR DAMAGE. CLEAN AND REPAIR AND/OR REPLACE DAMAGED PARTS.
- NEVER TAMPER WITH SAFETY DEVICES. CHECK THEIR PROPER OPERATION REGULARLY.
- DO NOT MOW IN THE RAIN. WATER ON THE SPARK PLUG MAY CAUSE THE ENGINE TO STALL.
- DO NOT OPERATE THE DR TRIMMER/MOWER ON SLOPES GREATER THAN 20 DEGREES.
- WHEN OPERATING OVER UNEVEN TERRAIN AND SLOPES, USE EXTREME CAUTION TO ENSURE SOLID AND FIRM FOOTING.

! WARNING!

- WHILE USING THE DR TRIMMER/MOWER, DO NOT HURRY OR TAKE THINGS FOR GRANTED. WHEN IN DOUBT ABOUT THE EQUIPMENT OR YOUR SURROUNDINGS, STOP THE MACHINE AND TAKE THE TIME TO LOOK THINGS OVER. MAKE SURE THAT YOU HAVE 100% CONTROL OF THE MOWER AT ALL TIMES.
 - NEVER OPERATE THE MACHINE WHEN UNDER THE INFLUENCE OF ALCOHOL, DRUGS, OR MEDICATION.
 - USE THE MACHINE ONLY IN DAYLIGHT.
 - WATCH FOR TRAFFIC WHEN MOWING NEAR ROADWAYS.
 - KEEP ALL NUTS AND BOLTS TIGHT AND KEEP THE EQUIPMENT IN GOOD OPERATING CONDITION.
 - NO LIST OF WARNINGS AND CAUTIONS CAN BE ALL-INCLUSIVE. IF SITUATIONS OCCUR THAT ARE NOT COVERED BY THIS MANUAL, THE OPERATOR MUST APPLY COMMON SENSE AND OPERATE THIS MACHINE IN A SAFE MANNER. CALL 1-800-DR-OWNER (376-9637) FOR ASSISTANCE.
-

A Note to All Users

Under California law, and the laws of some other states, you are not permitted to operate an internal combustion engine using hydrocarbon fuels without an engine spark arrester. This also applies to operation on US Forest Lands. All DR TRIMMER/MOWERS shipped to California and Washington State are provided with spark arresters. Failure of the owner/operator to maintain this equipment in compliance with state regulations is a misdemeanor under California law and may be in violation of other state and/or federal regulations. Contact your local fire marshal or forest service for specific information in your area.

Additional Information and Potential Changes

Country Home Products, Inc. reserves the right to discontinue, change, and improve its products at any time without notice or obligation to the purchaser. The descriptions and specifications contained in this manual were in effect at printing. Equipment described within this manual may be optional. Some illustrations may not be applicable to your machine.

SETTING UP YOUR DR TRIMMER/MOWER

This chapter outlines unpacking and a few simple steps you will need to follow to set up your new machine before you use it. It may be helpful to familiarize yourself with the controls and features on your machine by reviewing the pictures in the next section before beginning the steps outlined in this chapter. **If you have any questions at all, please feel free to contact our Customer Service Representatives at our Toll-Free number: 1-800-DR-OWNER (376-9637).**

DR TRIMMER/MOWER Controls and Features

NOTE: The models shown in **Figure 1** may look slightly different from your machine.

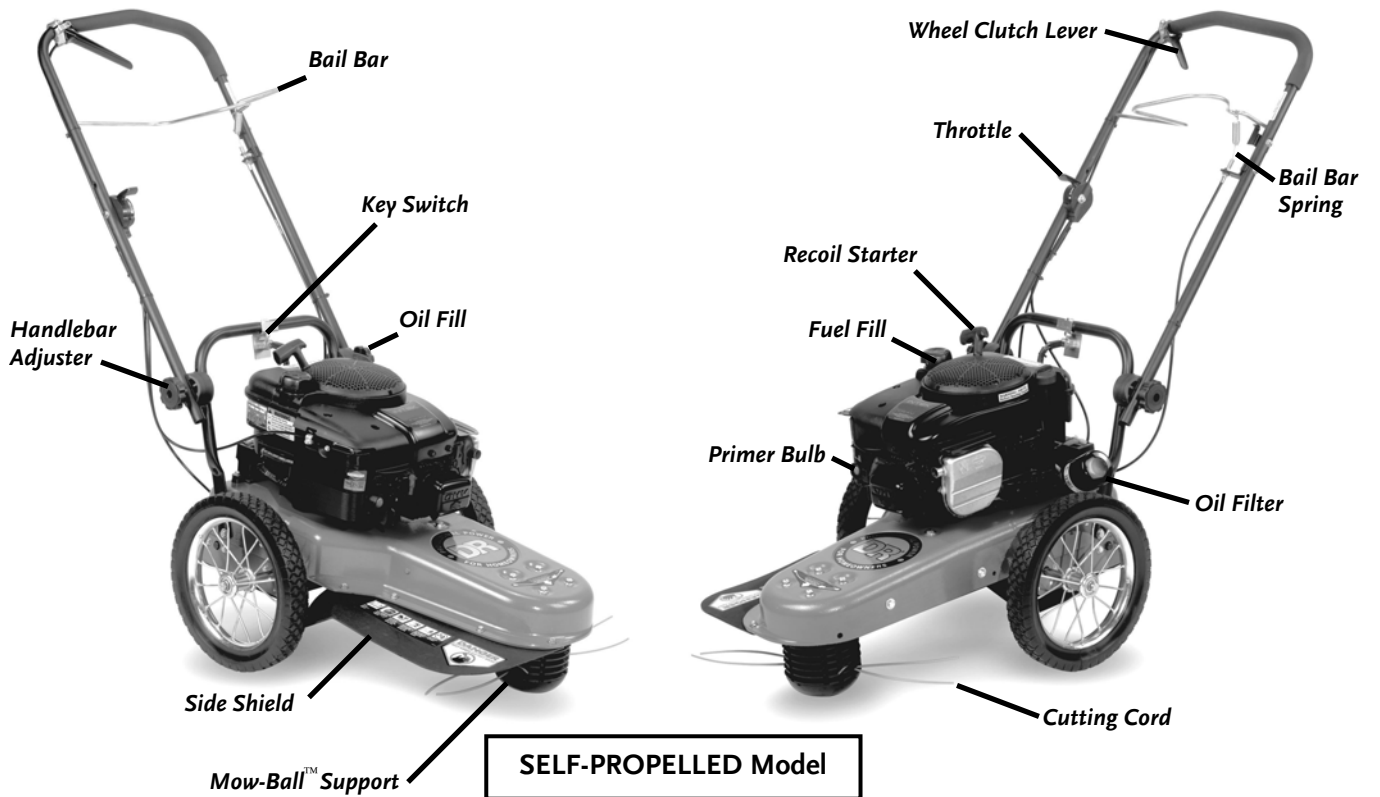
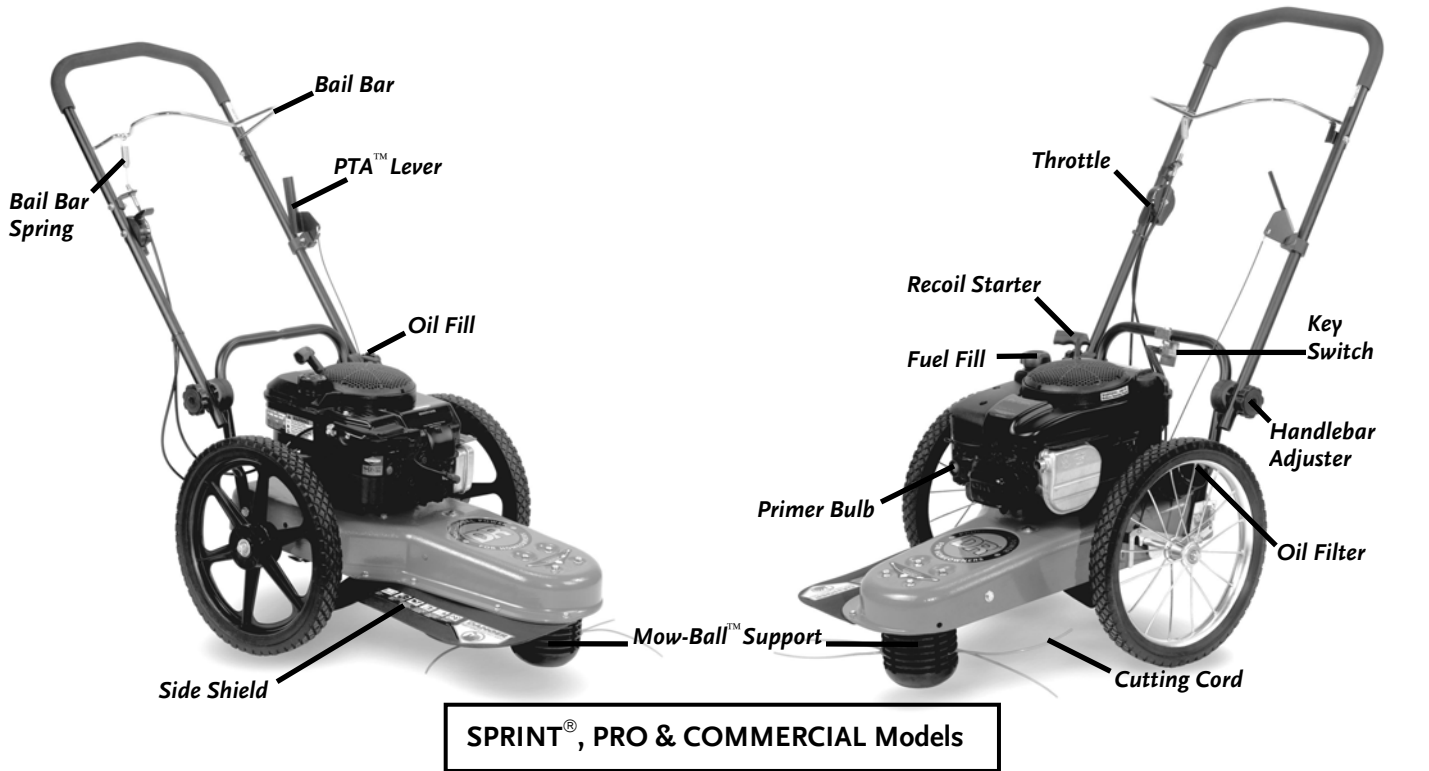

Unpacking the DR TRIMMER/MOWER

Country Home Products ships the following items with your new machine. Please check to make sure you have everything listed below:

Parts Supplied:

- (2) Key (for Electric Start models only)

NOTE: The Keys are attached to the Trimmer just below the bail bar spring (**Figure 1** on page 10).

- (1) Goggles for eye protection
- (1) Metal Head Locking Tool
- (1) Sample Pack of Trimmer Cord:
 - Small (Orange, .130")
 - Medium (Green, .155")
 - Large (Blue, .175")

1. With the shipping box placed with the arrows up (Trimmer Wheels down) and with help of another person, open the box and carefully remove your new DR TRIMMER/MOWER from the box and rest the machine on the wheels and Mow-Ball™ Support.

NOTE: Tipping the box onto the end with the wheels will allow you to roll out the machine.

2. Locate the plastic bag with the Product Pack containing the Head Locking Tool, Goggles, and Sample Pack of Cutting Cord.
3. Remove any remaining packing materials from the machine.
4. Compare the contents of the shipping carton and the plastic bag with the Parts Supplied list. **If any of the parts are missing, contact 1-800-DR-OWNER (376-9637).** Do not discard your packaging material until you are fully satisfied with your new DR TRIMMER/MOWER.

NOTE: Remove the plastic shipping caps from the ends of the wheel nuts on your new machine before using it and save them with your packing materials.

5. Add Engine oil and gasoline; reference page 12.

NOTICE!

BE SURE TO FILL THE ENGINE WITH OIL AND GAS BEFORE USE. IF YOU START THE ENGINE WITHOUT OIL IN THE CRANKCASE, THE ENGINE WILL BE DAMAGED BEYOND REPAIR AND WILL NOT BE COVERED UNDER THE WARRANTY. SEE THE NEXT PAGE FOR OIL AND FUEL FILL.

Adding the Engine Oil and Gasoline

NOTICE!

- **YOU MUST ADD OIL BEFORE STARTING THE ENGINE. THIS MACHINE SHIPPED WITHOUT OIL. TRACES OF OIL MAY BE IN THE RESERVOIR FROM FACTORY TESTING, BUT YOU MUST ADD OIL BEFORE STARTING THE ENGINE. FILL THE RESERVOIR SLOWLY, CHECKING THE DIPSTICK FREQUENTLY TO AVOID OVERFILLING.**
- **TO GET AN ACCURATE READING WHEN CHECKING THE OIL LEVEL:**
 - ⇒ **THE MACHINE SHOULD BE ON A LEVEL SURFACE.**
 - ⇒ **THE DIPSTICK SHOULD BE SCREWED DOWN ON BRIGGS & STRATTON ENGINES.**

Tip: To avoid confusion, we recommend leaving the caps on the fuel and Engine oil fills and only removing one cap each time when you are ready to pour gasoline or oil into the correct fill.

NOTE: *You will need approximately 15 to 22 ounces of SAE 30 high detergent oil depending on Engine type. Use only SAE 30 high detergent oil classified “For Service SF, SG, SH, SJ” or higher. Do not use special additives. Other types of oil could cause problems operating your machine. Please refer to your Engine Owner’s Manual for detailed information on oil quantity, and cold temperature oil specifications.*

1. Place the machine on a level surface and initially add 1/2 of the SAE 30 high detergent oil recommended by the Engine Manufacturer and wait one minute for the oil to settle (**Figure 2** on page 13).
2. Check the Dipstick and continue adding a few ounces of oil at a time, rechecking the Dipstick until the oil reaches the fill mark. Be careful not to overfill (**Figure 2** on page 13).

WARNING!

FILL GAS TANK OUTDOORS OR IN A WELL-VENTILATED AREA, AWAY FROM SPARKS, OPEN FLAMES, PILOT LIGHTS, HEAT, AND OTHER IGNITION SOURCES.

NOTE: *Discard the blue protective-shipping cap provided by some Engine Manufacturers. You will find this protective-shipping cap under the Gas Fill screw cap or in the tank Filler Tube. See your Engine Owner’s Manual for more fuel and oil information.*

3. Fill the gas tank with fresh, unleaded gas (with a minimum of 85 Octane), to approximately 1/4" below the top of the fill neck to allow for fuel expansion. Be careful not to overfill and reinstall the cap before starting the Engine. See your Engine Owner’s Manual for more information.

NOTE: *To refill the gas tank, turn the Engine OFF, and let the Engine cool at least two (2) minutes before removing the gas fill cap.*

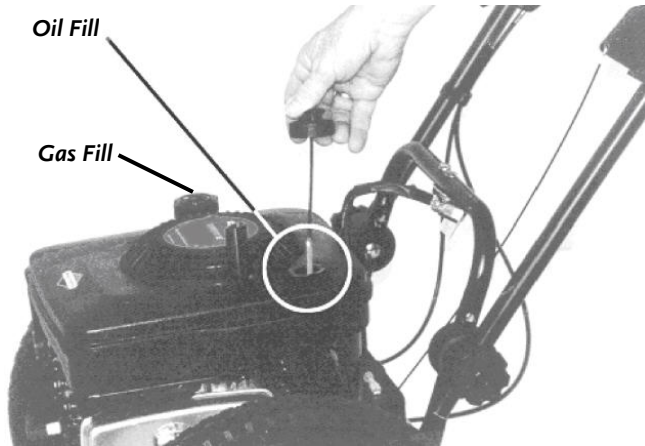

Figure 2

Connecting the Battery Wire (Electric-Starting Models Only)

We ship all Electric-Starting Trimmers with the negative Battery wire disconnected. This prevents the Battery from discharging during shipment. Before using your Trimmer, you must connect the Battery wire.

1. Connect the black wire by pushing the plastic connector onto the negative (-) Battery terminal as shown in **Figure 3**.

NOTE: The red wire should already be attached to the positive terminal.



Figure 3

Adjusting the Handlebar

It is important to find a Handlebar height that allows the Mow-Ball™ Support to glide along the ground and remain balanced so you do not have to push down or pull up on the Handlebar.

At the proper height, your hands should rest at a comfortable level and the front end of the Trimmer should roll easily on the Mow-Ball™ Support as shown in **Figure 15** on page 25. You may find you like different Handlebar heights for different mowing conditions.

There are two ways to adjust the height of the Handlebar outlined in the following steps:

1. Loosen both the Adjustment Knobs and move the Handlebar up or down until the adjustment is the same on both sides. Use the Notches on the Adjusters (**Figure 4a**) to measure how many Teeth you have moved away from the center. When you have found a comfortable height, tighten the Adjustment Knobs securely.
2. For additional height adjustment options, there are two holes in the upper and lower Handlebars where the Adjustment Knobs are located (**Figure 4b**). Most people start with the Handlebars set in the lower holes of both the upper and lower Handlebar. You can adjust the height up or down by removing the Adjustment Knob Assembly and repositioning the Handlebars to a higher or lower hole. Be sure the Notches in the two Adjusters line up when you reassemble them (**Figure 4a**). You may need to adjust the PTA™ Lever as well. See the next section.

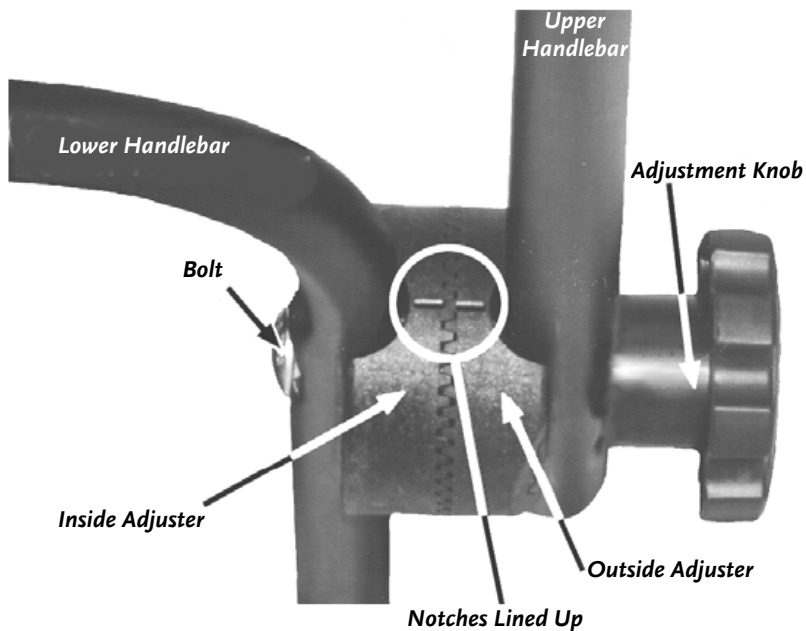

Figure 4a

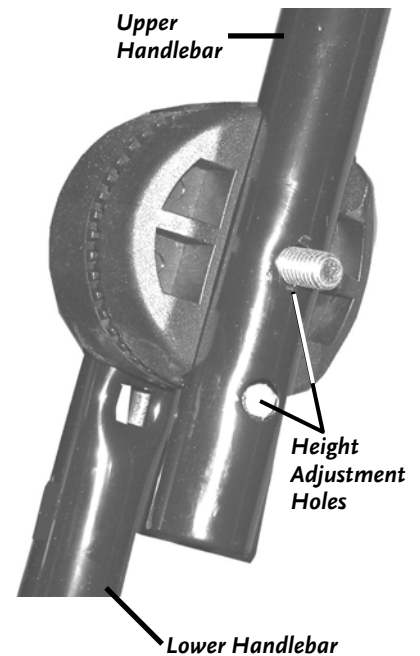

Figure 4b

Adjusting the PTA™ (Parallel Trimming Action) Lever - SPRINT® , PRO and COMMERCIAL

! WARNING!

BEFORE PERFORMING ANY ADJUSTMENT, MAINTENANCE PROCEDURE OR INSPECTION, STOP THE ENGINE, WAIT FIVE (5) MINUTES TO ALLOW PARTS TO COOL AND DISCONNECT THE SPARK PLUG WIRE, KEEPING IT AWAY FROM THE SPARK PLUG.

NOTE: This adjustment is not applicable to the SELF-PROPELLED model.

It is easy to adjust the PTA™ feature. If you have moved the Handlebar up or down, the PTA™ (Parallel Trimming Action) Lever may need adjustment. When the PTA™ feature is properly engaged, there should be just a little slack in the cable. For more information on PTA™, please read the section called Using PTA™ (Parallel Trimming Action) on page 20.

1. Loosen the Knob on the PTA™ Control by turning it counterclockwise (**Figure 5**).
2. Move the Assembly up the Handlebar to tighten the cable or down the Handlebar to loosen it.
3. Retighten the Knob.

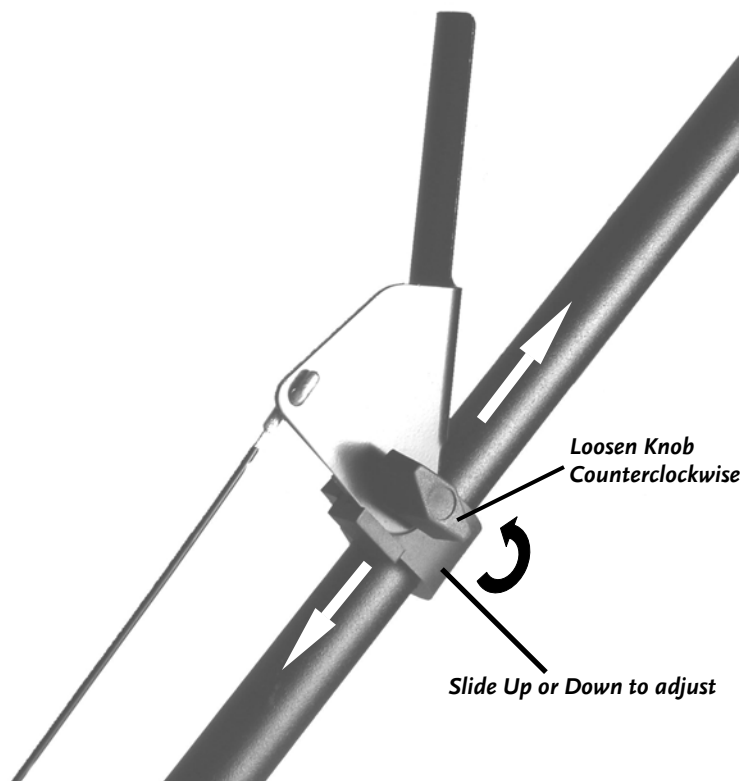

Figure 5

OPERATING YOUR DR TRIMMER/MOWER

This chapter covers the procedures for starting and stopping your new DR TRIMMER/ MOWER and discusses basic operation features. You may find it helpful to review the DR TRIMMER/MOWER Controls and Features picture (*Figure 1* on page 10) before reading this chapter.

WARNING!

- THE DESIGN OF YOUR MACHINE IS FOR TRIMMING AND MOWING GRASS, WEEDS, AND OTHER GROWTH AS SPECIFIED IN THIS MANUAL. DO NOT USE IT FOR ANY OTHER PURPOSE AS IT COULD CAUSE SERIOUS INJURY.
 - CONTACT WITH INTERNAL ROTATING PARTS WILL CAUSE SERIOUS PERSONAL INJURY. NEVER PUT HANDS, FACE, FEET, OR CLOTHING UNDER THE MOWER DECK OR DISCHARGE OPENING AT ANY TIME.
 - BEFORE PERFORMING ANY ADJUSTMENT, MAINTENANCE PROCEDURE OR INSPECTION, STOP THE ENGINE, WAIT FIVE (5) MINUTES TO ALLOW PARTS COOL. DISCONNECT THE SPARK PLUG WIRE, KEEPING IT AWAY FROM THE SPARK PLUG.
-

Before Starting the Engine

1. Check the oil level every time you use the DR TRIMMER/MOWER (*Figure 2* on page 13).
2. Check the gas level (*Figure 2* on page 13).
3. Remove any debris buildup from the underside of the machine.

Electric-Starting

NOTE: Use the following steps with electric-starting models only.

1. Push the Throttle Control Lever on the right side of the Handlebar (**Figure 1** on page 10) all the way forward to the RABBIT (Fast) position.
2. If your model has an Engine Primer, push the Primer Bulb IN (**Figure 1** on page 10) and completely release it, lifting your finger and letting it pop back to its original position. Repeat three to four times.

NOTE: Priming is usually not necessary when restarting a warm engine. In cool weather, you may need to repeat the priming operation.

3. Turn the Key (**Figure 1** on page 10) to the START position until the engine starts, then release. The Key will snap back to the RUN position and the engine will continue to run.

NOTE: Do not engage the Bail Bar (Trimmer Head Control) until after the engine has started.

Manual-Starting

NOTE: You may use this starting method with both Manual and Electric-Starting models.

1. Push the Throttle Control Lever on the right side of the Handlebar (**Figure 1** on page 10) all the way forward to the RABBIT (Fast) position.
2. If your model has an Engine Primer, push the Primer Bulb IN (**Figure 1** on page 10) and completely release it, lifting your finger and letting it pop back to its original position. Repeat three to four times.

NOTE: Priming is usually not necessary when restarting a warm engine. In cool weather, you may need to repeat the priming procedure.

3. Grasp the Recoil Starter Handle (**Figure 1** on page 10) and slowly pull until you feel resistance. Let the cord retract a little bit, then pull the cord rapidly to start the engine. One or two pulls usually starts the DR TRIMMER/MOWER. It may be necessary to repeat the priming operation if the machine does not start within two pulls.

NOTE: Do not engage the Bail Bar (Trimmer Head Control) until after the engine has started.

Stopping the Engine

1. Move the Throttle Control Lever (**Figure 1** on page 10) all the way back past the TURTLE (Slow) position to the STOP position.

NOTE: If you have an Electric-Starting model, please note that the Key does not stop the engine. You must follow these instructions to stop the engine for both Electric and Manual-Starting models.

2. Remove the Key for safety. The Key has a pressure lock that prevents it from vibrating loose during operation. To remove the Key, push it in and then quickly and firmly pull it out. If the Key becomes difficult to remove, apply SAE 30 Oil into the keyhole.

Engaging the Trimmer Head

Bring the Bail Bar toward you and grip it together with the Handlebar (**Figure 1** on page10). Keep holding the Bail Bar to the Handlebar. The Cutting Cords will rotate and will continue to rotate until you release the Bail Bar.

Stopping the Cords from Spinning

Release the Bail Bar from the Handlebar. The Trimmer Head will stop spinning while the engine continues to run.

Engaging the Wheel Drive - SELF-PROPELLED model

The SELF-PROPELLED DR TRIMMER/MOWER has a single speed forward transmission.

1. Gently squeeze the Clutch Lever (**Figure 1** on page 10) to engage the wheel drive.
2. Release the Clutch Lever to stop the wheel drive.

Using the PTA™ (Parallel Trimming Action) - SPRINT®, PRO and COMMERCIAL models only

Your DR TRIMMER/MOWER'S PTA™ feature allows you to move the machine in a straight line while the Trimmer Head is both pivoted and tilted to the left for better access to fence lines and other obstacles. PTA™ allows you to trim in difficult areas without having to pull the machine back and forth.

The following two sections explain how to use the PTA™ and how to return your Trimmer to Normal operation after using PTA™.

! WARNING!

USE CAUTION WHEN EDGING ALONG GRAVEL PATHS AND DRIVEWAYS. FLYING DEBRIS CAN CAUSE SERIOUS DAMAGE AND INJURY.

! NOTICE!

WHEN USING PTA™, YOU SHOULD INSTALL THE CUTTING CORDS IN ONE OF THE BOTTOM FOUR LINE PLATES ONLY. USING THE UPPER LINE PLATES MAY CAUSE THE CORDS TO HIT THE WHEEL. FOR MORE INFORMATION, SEE THE DR TRIMMER/MOWER CUTTING CORDS ON PAGE 22.

NOTE: In PTA™ mode, the Trimmer's wheels stay straight while the Trimmer Head tilts as shown in **Figure 6**. The Cutting Cords extend beyond the wheelbase in the PTA™ mode (**Figure 6**), allowing you to easily cut under obstacles. The Trimmer Head and the Cutting Cords also tilt slightly in PTA™ mode so you can edge and trim along gardens, paths, and driveways (**Figure 6**). When using PTA™ along garden edges, fences, and buildings, we recommend making your first pass with the DR TRIMMER/MOWER in the Normal mowing position, staying 4 to 8 inches from the obstacle; and then return for another pass with the machine in PTA™ mode.

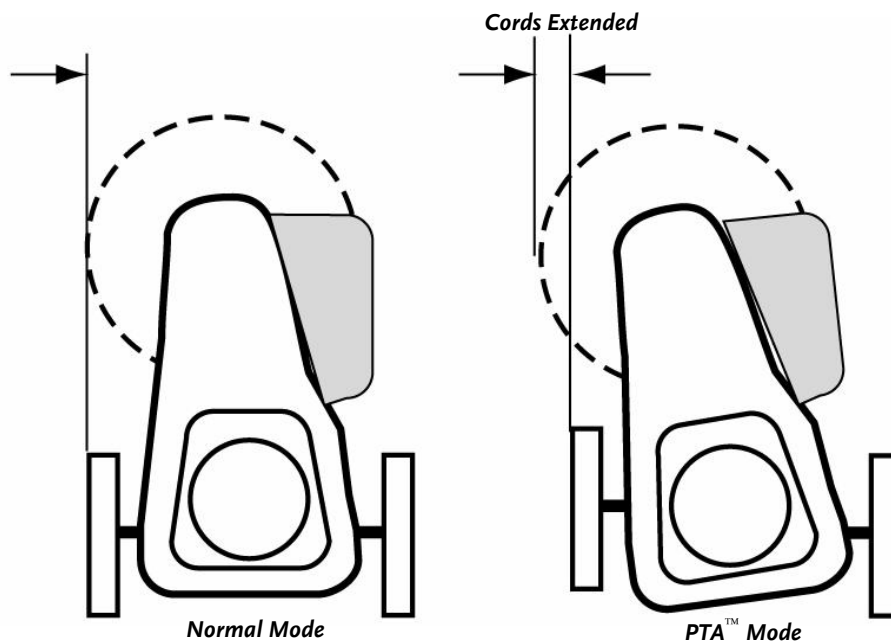

Figure 6

Engaging the PTA™

1. Stand in the operator's position.
2. Pull the PTA™ Lever (**Figure 7**) against the Handlebar and hold it there. This unlocks the Axle (**Figure 8**).

NOTE: **Figure 8** shows the Axle with the wheel removed for clarity.

3. Push down on the Handlebar to tip the nose of the machine a few inches off the ground. Balancing the weight of the machine on the wheels makes it easier to pivot the front of the Trimmer to the left.
4. While continuing to hold the PTA™ Lever down, grip the sides of the Handlebar pulling up with the right hand and pushing down with the left, swinging the front of the Trimmer to the left.
5. Release the PTA™ Lever. This will lock the Axle in PTA™ mode (**Figure 8**).



Figure 7

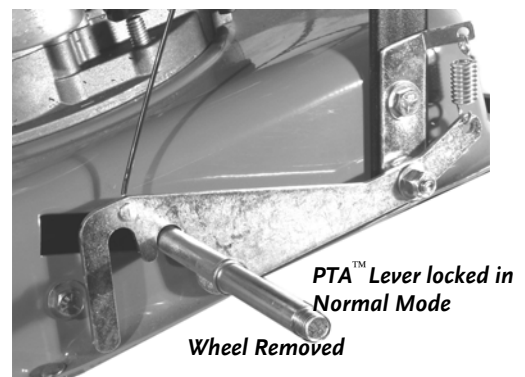
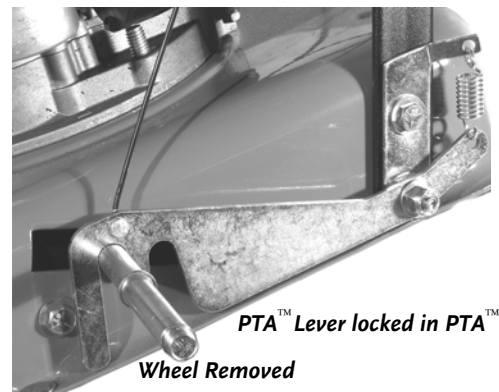
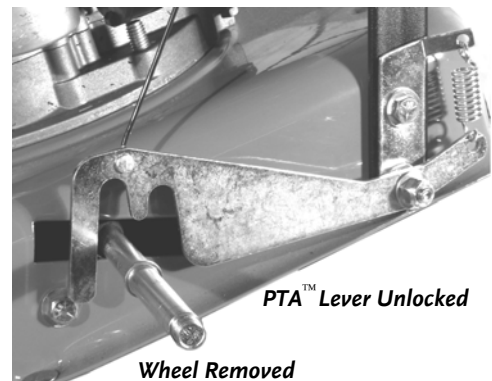

Figure 8

Returning to Normal Mode

1. Pull the PTA™ Lever (**Figure 7**) against the Handlebar and hold it there.
2. Push down on the Handlebar to tip the nose of the machine up a few inches off the ground.
3. While continuing to hold the PTA™ Lever down, grip the sides of the Handlebar while pulling up with the left hand and pushing down with the right, swinging the front of the Trimmer to the right, and stopping at center.
4. Release the PTA™ Lever. This locks the Axle in the Normal operation mode (**Figure 8**).

The DR TRIMMER/MOWER Cutting Cords

! WARNING!

BEFORE PERFORMING ANY ADJUSTMENT, MAINTENANCE PROCEDURE OR INSPECTION, STOP THE ENGINE, WAIT FIVE (5) MINUTES TO ALLOW PARTS TO COOL AND DISCONNECT THE SPARK PLUG WIRE, KEEPING IT AWAY FROM THE SPARK PLUG.

! NOTICE!

RUNNING THE TRIMMER WITH ONLY ONE CORD INSTALLED, OR CORDS INSTALLED AT OTHER THAN 180 DEGREES APART CAN CAUSE EXCESSIVE VIBRATION AND MAY DAMAGE THE MACHINE.

The following figures (*Figures 9 and 10*) illustrate the Cords installation on the line plates. These figures show the Line Plates from a cross section point of view. It may look complicated, but once you have done it a couple of times, it's easy. There are two (2) sets of installation points on each Line Plate. Each pair is 180 degrees apart. One (1) set of holes is for larger Cord (Blue, 175 mil, and Green, 155 mil) and is marked with large arrows. The other set of holes is marked with small arrows and are at 90 degrees to the larger holes and they accommodate the smaller Cord (Orange, 130 mil). Always install two (2) Cords, one opposite the other.

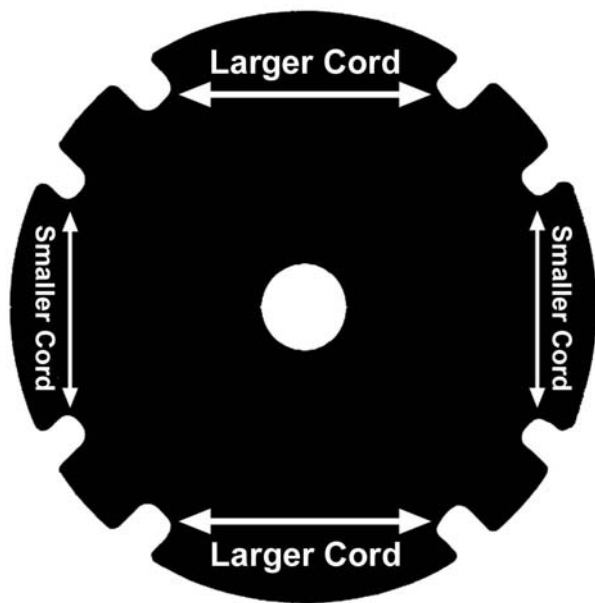

Figure 9

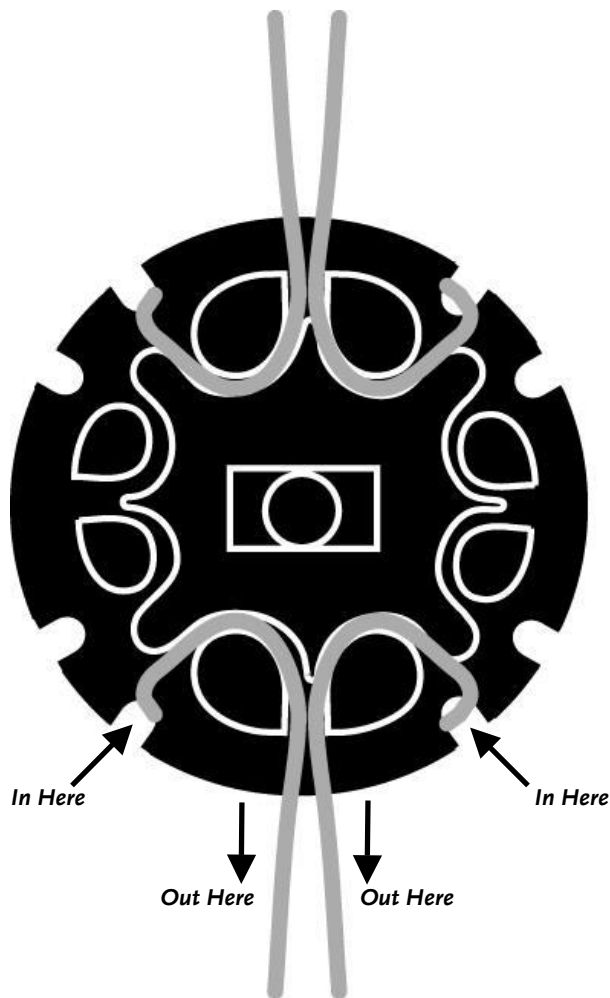

Figure 10

Installing Cords

The Cord installation method is shown in **Figures 11–13**. Your DR TRIMMER/MOWER shipped from the factory with the Cords installed in this manner.

! NOTICE!

WHEN USING PTA™, INSTALL THE CUTTING CORDS IN ONE OF THE BOTTOM FOUR LINE PLATES. INSTALLING THE CUTTING CORDS ON THE UPPER LINE PLATES CAN CAUSE THE CORD TO HIT THE WHEEL. FOR MORE INFORMATION ON USING PTA™, SEE USING PTA™ ON PAGE 20.

NOTE: After you install the Cords, and before trimming, engage the Cutting Head with the engine running and spin new Cords for a few seconds so they pull tight and are set.

1. Insert the ends of the Cords into the openings in the Line Plate, as shown in **Figure 11**. There are different sized arrows at the insertion points to indicate what size Cords fit the holes.
2. Push the Cord through until it comes out the center hole in the Line Plate as shown in **Figure 12**. You may also reference **Figures 9 and 10** for installing the Cords. Adjust the Cords so the tips are even.
3. Pull the Cords through the loop and push the loop up into the Line Plate groove above them, (**Figure 13**), and then pull the Cords tight.

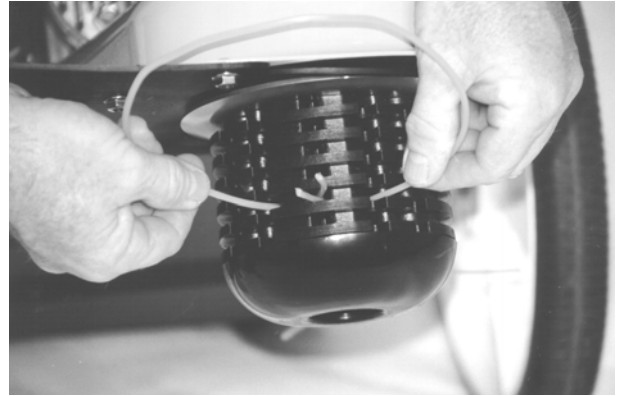

Figure 11



Figure 12

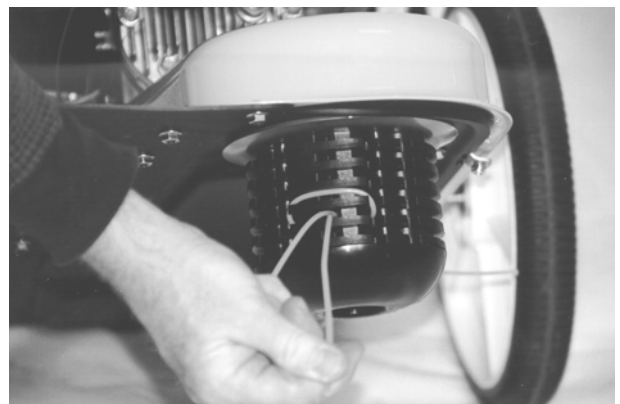

Figure 13

Cord Tips

We ship three (3) thicknesses of Cutting Cord with your DR TRIMMER/MOWER.

The Cords are Blue (175-mil), Green (155-mil) and Orange (130-mil). Because conditions and vegetation vary so much, you should experiment with Cord weights (diameters) to discover what works best for your particular mowing and trimming situations. Here are a few things to keep in mind:

- If you buy Cutting Cord in rolls, cut it in 23" lengths.
- Cord life depends on trimming conditions. Replace Cords when they become broken or frayed.
- The smallest diameter Cord capable of cutting the material at hand combined with the fastest engine speed usually provides the best grass trimming performance. When you need more power for thicker growth such as berry canes, brambles, thistles, or ragweed, you may want to use the 155-mil or 175-mil Cord in combination with the highest engine speed.
- Ease the ends of the Cord into heavy growth and move slowly through thick growth. If there are woody weeds in the material you are cutting, the cutting Cords may wrap around the stalks they cannot cut, and pull away from the trimmer head.
- Please note that installing more than two (2) Cords at a time does not improve trimming performance, in fact, it can lessen it. Adding additional Cords creates drag on the Trimmer Head, robs the engine of power, and may cause wrapping. Installing two (2) Cords, 180 degrees apart, is the best method for optimal trimming performance.
- When replacing Cords, do it one at a time and use the old Cord to mark the position for the new Cord that you are replacing.
- If the Cord breaks off flush at the Line Plate, use the new Cord to push out the old Cord.
- Storing the Cord in a plastic bag with a damp sponge or cloth will help keep it pliable. You can also soak your Cutting Cord in a bucket of room temperature water for a few days before use to make it more pliable.

Adjusting the Cutting Height

! NOTICE!

WHEN USING THE PTA™ FEATURE, INSTALL THE CUTTING CORDS IN ONE OF THE FOUR BOTTOM LINE PLATES ONLY.

Adjusting the cutting height is easy. Cutting heights range in 1/2-inch increments from 1-1/2 inches when using the bottom Line Plate, to approximately 4 inches when using the top Line Plate (**Figure 14**).

Install the Cutting Cords in the Line Plate that gives you the desired cutting height.

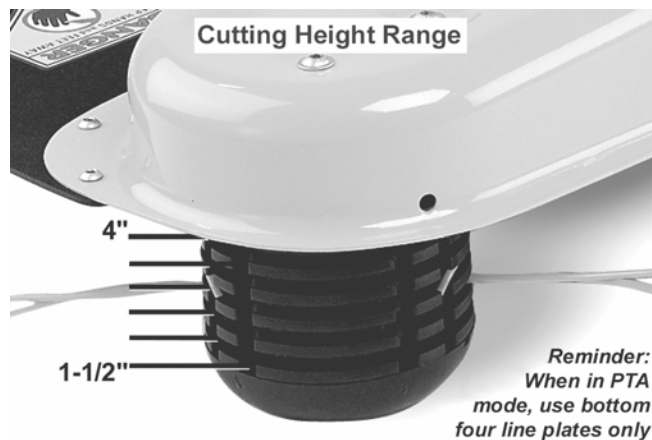

Figure 14

The Mow-Ball™ Support

Allow the front end of the machine to rest lightly on the Mow-Ball™ Support as you are trimming. The Mow-Ball™ Support should glide on the ground as you maneuver the machine. To achieve the best and smoothest cut, do not lift up on the Handlebar while operating your DR TRIMMER/ MOWER. Lifting the Handlebar will force weight down on the Mow-Ball™ Support. This uses more energy, slows the cutting, and produces an unsatisfactory cut. Ideally, the Mow-Ball™ Support should lightly rest on the ground while the wheels balance most of the weight of the machine (**Figure 15**).



Figure 15

Obstacle Tips

Dealing with obstacles in the terrain is easy with your new DR TRIMMER/MOWER. The following section explains how to approach most common obstacles.

! WARNING!

THE TRIMMER ENGINE'S POWER CAN EASILY THROW STONES, STICKS, AND OTHER DEBRIS AT GREAT VELOCITY, WHICH COULD CAUSE PERSONAL INJURY OR PROPERTY DAMAGE. DO NOT RUN THE MACHINE OVER GRAVEL DRIVEWAYS OR OVER LOOSE STONES OR MULCH WITH THE TRIMMER HEAD SPINNING.

Tip: The DR TRIMMER/MOWER discharges cut material to the right. Always try to cut and trim with the uncut tall grass or weeds on the left.

- Always check your work area before trimming and remove any debris that might tangle or damage the machine.
- If you do run into debris and the trimmer becomes tangled, turn off the engine and disconnect the spark plug wire before attempting to untangle the machine.
- For the neatest appearance, do your trimming first, discharging clippings away from borders and shrubs, then do your mowing.
- Many owners like to mow easy, open areas with their regular riding or walk-behind mower and finish trimming all the odd and hard-to-reach spots with the DR TRIMMER/MOWER (**Figure 16**).



Figure 16

Heavy Growth

- Take your time in heavy growth.
- Be sure to keep uncut material to your left, maintaining a clear discharge area to your right (**Figure 17**).
- If the machine cannot do it all in one pass, overlap half of the cutting swath.
- If the grass is very thick and heavy, try raising the Trimmer Head off the ground a few inches by pushing down on the Handlebar. Cut the material at this height, and then make a second pass with the Mow-Ball™ Support close to the ground.
- Ease the DR TRIMMER/MOWER into denser growth. If the material is too tough or woody to cut, the Cutting Cords will wrap around it, wear down, or even break off.
- Sometimes the growth is so heavy, you cannot mow it in rows. Use a forward and back “vacuum cleaner” motion in these cases.

Tips:

- Use the “two pass”, one half overlap method, whenever possible.

SELF-PROPELLED Model Tips:

- In heavy growth it is best to make two (2) passes at 1/2 the cutting width.
- If you must go back and forth in the “vacuum cleaner” motion, be sure to release the Wheel Clutch Lever when pulling the Trimmer back.

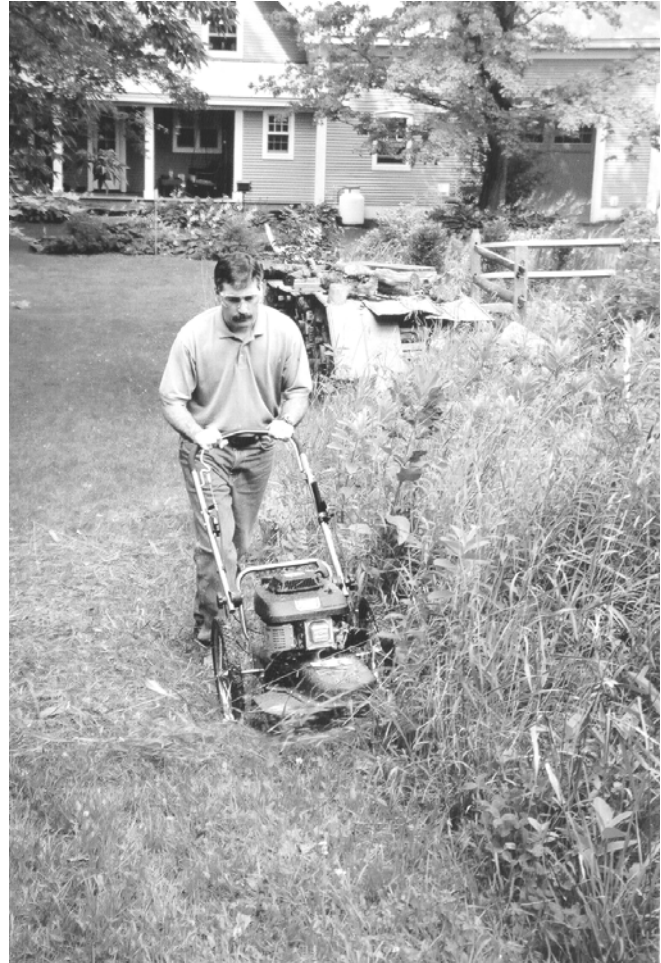

Figure 17

! WARNING!

MAKE SURE OF YOUR FOOTING WHEN OPERATING IN WET CONDITIONS.

Wet Conditions

Because there is no housing to restrict the flow of cut material, you can also use your DR TRIMMER/MOWER to mow wet or heavy growth. You can use the DR in damp conditions, after a rain, or in the early morning dew without clogging or stalling. You can also mow wet areas such as ditches and around ponds (**Figure 18**).

NOTE: NEVER mow in the rain. Water on the spark plug may cause the engine to stall.



Figure 18

Very Dry Conditions

! NOTICE!

FREQUENTLY REMOVE DEBRIS FROM THE RECOIL GUARD ON TOP OF THE ENGINE AND THE COOLING FINS ON THE FRONT OF THE ENGINE TO PREVENT OVERHEATING AND ENGINE DAMAGE.

When trimming and mowing in very dry conditions, be extra cautious of cut grass, chaff, weeds, seeds, etc., accumulating on the engine, especially around the recoil-starter housing and engine cooling fins. Please see the Engine Owner's Manual for more detailed information on cleaning the air intake, air filter, and cooling system on the engine.

Slopes

! WARNING!

MAKE SURE OF YOUR FOOTING WHEN OPERATING ON SLOPES.

You can trim and mow on slopes up to 20 degrees. Continuous use on slopes steeper than 20 degrees may deprive the engine of adequate lubrication, and damage components.

Windrows

The DR TRIMMER/MOWER Cutting Cords cut even tall grass in just one pass, so you can collect clippings and leaves for mulch without raking. The machine ejects cut material to its right side, so you can use it like a lawn broom to make windrows for easy clean-up.

Firebreaks

Use your Trimmer as a labor saving tool to cut material when creating firebreaks.

Garden Clean-Up

The DR TRIMMER/MOWER is perfect for cutting down dead perennials, annuals, and wildflowers, saving you hours of hand pruning and deadheading. You can also re-cut downed material a second time to create mulch for garden beds.

CHAPTER 5

MAINTAINING THE DR TRIMMER/MOWER

This chapter covers regular maintenance procedures that will ensure the best performance and long life of your DR TRIMMER/MOWER. For Engine maintenance, please refer to the Engine Owner's Manual that came with your Trimmer. Service intervals listed in the checklist below supercede those listed in the Engine Owner's Manual.

WARNING!

BEFORE PERFORMING ANY MAINTENANCE PROCEDURE OR INSPECTION, STOP THE ENGINE, WAIT FIVE (5) MINUTES TO ALLOW ALL PARTS COOL. DISCONNECT THE SPARK PLUG WIRE, KEEPING IT AWAY FROM THE SPARK PLUG.

Regular Maintenance Check List

NOTE: Consider that the service intervals shown are the maximum under normal operating conditions. Increase frequencies under extremely dirty or dusty conditions.

Procedure	Before Each Use	Every 25 Hours	Every 100 Hours
Check the Engine Oil level.	▲		
Check the general equipment condition, e.g. Nuts, Bolts, Welds, etc.	▲		
Check and clean out the Mow-Ball™ Support.	▲		
Replace broken or frayed Cutting Cords.	▲		
Check the Mow-Ball™ Support Line Plates for wear.	▲		
Clean Engine Exterior, Cooling Fins and remove collected grass trimmings.	▲		
Check the Belt for fraying or stretching.		▲	
Lubricate Throttle Cable, Trimmer Control Cable and Idler Pulley with SAE 30 Oil.		▲	
Clean Engine Air Foam Filter		▲	
Change the Engine Oil and the Oil Filter*	1 st time 5 hrs.	▲	
Replace the Engine Paper Air Filter Cartridge		▲	
Adjust Clutch Cable on the SELF-PROPELLED model.		▲	
Remove the Bottom Shield and clean out collected debris.		▲	
Replace the Spark Plug			▲

* An Oil Filter is on COMMERCIAL and SELF-PROPELLED models only.

Battery Care (Electric-Start Models)

Proper care can extend the life of a battery. Follow these recommendations to ensure your battery's best performance and long life:

- Do not allow the battery charge to get too low. If the machine is not used, charge the battery every 4 – 6 weeks. Operate the engine for at least 45 minutes to maintain proper battery charge.
- Store an unused battery in a dry area that does not freeze.
- Do not charge an already charged battery. In theory, you cannot overcharge our battery with a trickle charger; however, when a battery is fully charged and the charger is still on, it generates heat that could be harmful to the battery. A fully charged battery will read 12V-13.2V with a voltmeter.
- Do not continue to crank your engine when the battery charge is low.

Charging the Battery

Operate the Trimmer engine for at least 45 minutes to maintain proper battery charge. If the battery loses its charge, you will need to use a trickle charger (like the DR Battery Charger) to recharge it. The charger should have an output of 12 volts at no more than 2 amps.

- At 1 amp, the battery may need charging for as long as 48 hours.
- At 2 amps, the battery may need charging for as long as 24 hours.

NOTE: *Using the recoil starter and then running the engine will not recharge a dead or significantly discharged battery.*

To connect a battery charger to your DR TRIMMER/MOWER, follow the steps listed below.

1. Detach the two battery wires going to the battery on your DR TRIMMER/ MOWER.
2. Attach the black (-) battery charger wire to the battery negative (-) terminal, and attach the red (+) battery charger wire to the battery positive (+) terminal.
3. Plug the battery charger into an outlet.

NOTICE!

WHEN YOU ARE FINISHED CHARGING THE BATTERY, DISCONNECT THE CHARGER FROM THE OUTLET FIRST, THEN DISCONNECT THE BATTERY CHARGER WIRES FROM THE BATTERY. IF YOU LEAVE THE BATTERY CHARGER WIRES CONNECTED TO THE BATTERY, THE BATTERY WILL DISCHARGE ITSELF BACK INTO THE CHARGER.

Removing the Mow-Ball™ Support Assembly

! WARNING!

BEFORE PERFORMING ANY MAINTENANCE PROCEDURE OR INSPECTION, STOP THE ENGINE, WAIT FIVE (5) MINUTES TO ALLOW ALL PARTS COOL. DISCONNECT THE SPARK PLUG WIRE, KEEPING IT AWAY FROM THE SPARK PLUG.

Tools Needed: You will need the Head Locking Tool supplied with your DR TRIMMER/MOWER or a #3 Phillips head screwdriver with at least a 6" shank. We recommend wearing Gloves when tightening or loosening the Mow-Ball™ Support Assembly.

1. Insert the Head Locking Tool or screwdriver into the hole in the Frame, then rotate the Mow-Ball™ Support Assembly until the tool fits into a second hole in the shaft, locking it into place (**Figure 19**).
2. Looking down at the top of the Frame, turn the Mow-Ball™ Support Assembly clockwise until it unscrews completely from the bearing housing (**Figure 20**). Remove the tool or screwdriver after you have removed the Mow-Ball™ Support Assembly.

NOTE: If the Mow-Ball™ Support Assembly continues to turn, but does not come off, check to be sure the Head Locking Tool or screwdriver is locked into the shaft.

3. To reinstall the Mow-Ball™ Support Assembly, reverse the above instructions.

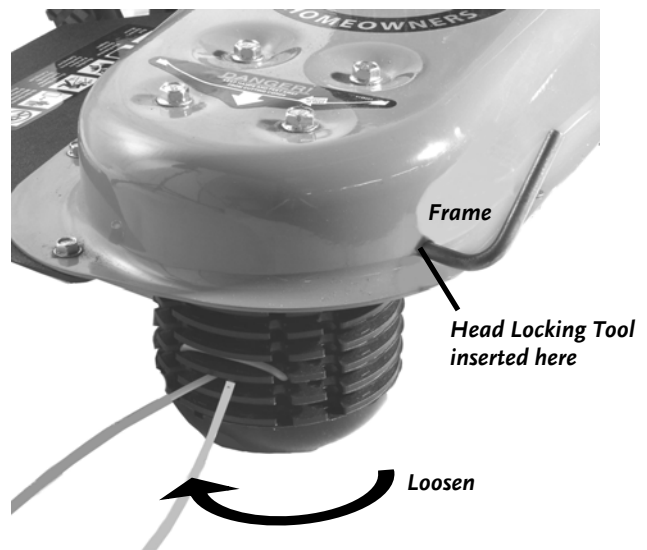

Figure 19



Figure 20

Reassembling the Mow-Ball™ Support Assembly

! WARNING!

BEFORE PERFORMING ANY MAINTENANCE PROCEDURE OR INSPECTION, STOP THE ENGINE, WAIT FIVE (5) MINUTES TO ALLOW ALL PARTS COOL. DISCONNECT THE SPARK PLUG WIRE, KEEPING IT AWAY FROM THE SPARK PLUG.

! NOTICE!

IMPROPER INSTALLATION CAN CAUSE DAMAGE TO THE TRIMMER BEARINGS. FOLLOWING THESE DIRECTIONS CAREFULLY WILL PROTECT YOUR MACHINE FROM DAMAGE. REASSEMBLE THE COMPONENTS IN THE ORDER SHOWN IN *FIGURE 21*.

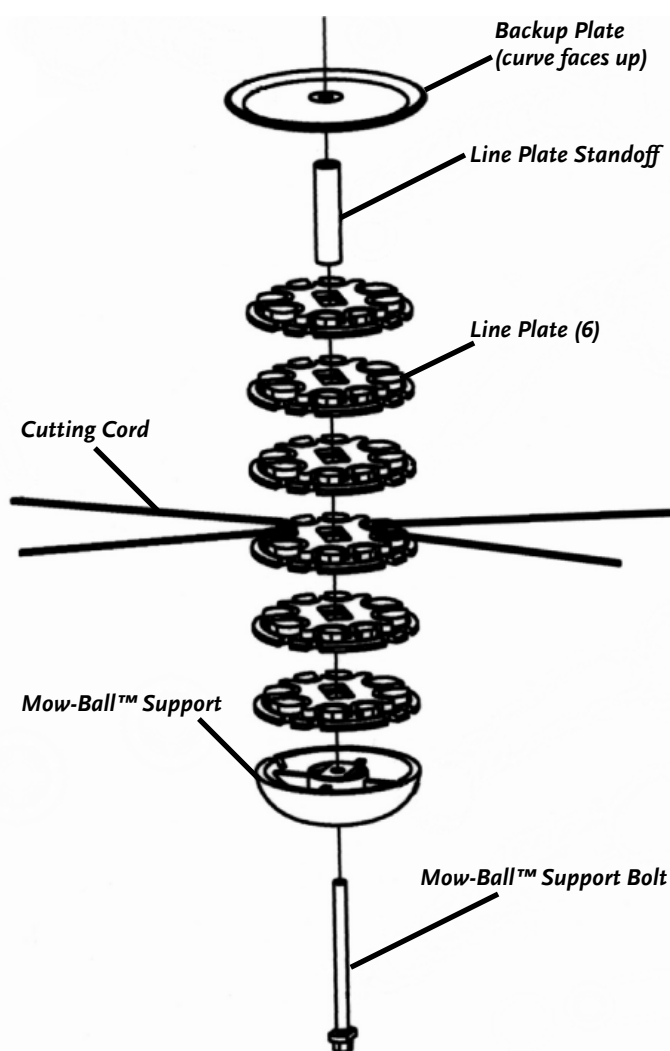

Figure 21

1. Position the Backup Plate with the lip of the curve facing up (*Figure 21*).
2. Stack the Line Plates on top of one another with the bumps on the bottom locking into the grooves on top of each Plate.
3. Insert the Line Plate Standoff onto the center of the stack (*Figure 21*).
4. Place the head of the Mow-Ball™ Support Bolt so it is sitting in the groove at the bottom of the Mow-Ball™ Support.
5. Hold the bolt head in place with your finger and turn the Mow-Ball™ Support Assembly clockwise until it is finger tight.
6. Insert the Head Locking Tool or screwdriver as shown in *Figure 19* on page 31 and tighten the assembly securely by turning the Mow-Ball™ Support Assembly counterclockwise.

NOTE: If there is a space between any of the components of the assembled Mow-Ball™ Support, repeat the stacking procedure.

Removing the Stone Guard Flap - SPRINT[®], PRO, and COMMERCIAL

WARNING!

BEFORE PERFORMING ANY MAINTENANCE PROCEDURE OR INSPECTION, STOP THE ENGINE, WAIT FIVE (5) MINUTES TO ALLOW ALL PARTS COOL. DISCONNECT THE SPARK PLUG WIRE, KEEPING IT AWAY FROM THE SPARK PLUG.

NOTE: We turned the Trimmer on its side to take the photos in this section. To do so, we removed gas and oil from the machine. You can access the underside of the Trimmer without having to drain gas and oil by tilting back on its handlebar.

Tool Needed:

- 3/8" Wrench or Socket

Remove the screws on either side of the Stone Guard and drop it from the Frame (**Figure 22**).

Tip: Keep the screws together with the stone guard.

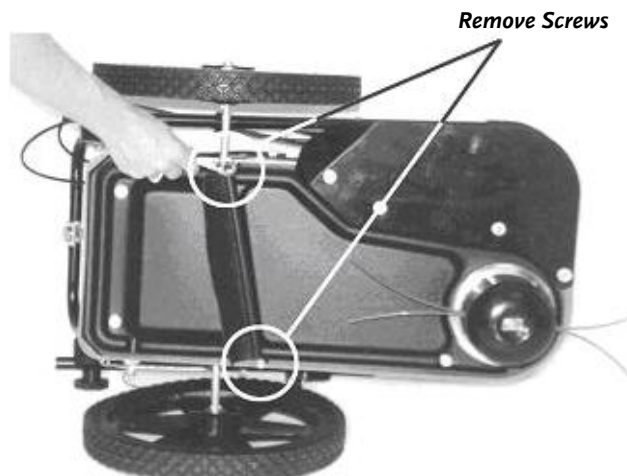

Figure 22

Removing and Replacing Section:

Bottom Shield - SPRINT[®], PRO, and COMMERCIAL

WARNING!

BEFORE PERFORMING ANY MAINTENANCE PROCEDURE OR INSPECTION, STOP THE ENGINE, WAIT FIVE (5) MINUTES TO ALLOW ALL PARTS COOL. DISCONNECT THE SPARK PLUG WIRE, KEEPING IT AWAY FROM THE SPARK PLUG.

NOTE: You do not need to remove the side shield or any of its hardware when removing the bottom shield.

Tool Needed:

- 7/16" Wrench or Socket
1. Remove the Mow-Ball™ Support Assembly. See "Removing the Mow-Ball™ Support Assembly" on page 31.
 2. Remove the Stone Guard Flap. See "Removing the Stone Guard Flap" above.
 3. Remove the two (2) mounting Bolts and Washers at the rear of the Frame (**Figure 23**).

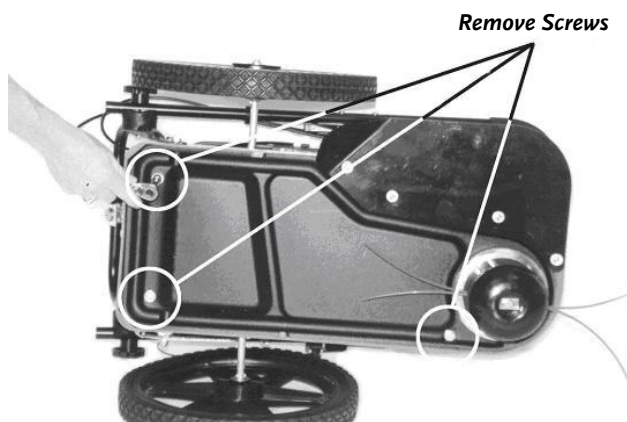

Figure 23

4. Remove the third mounting Bolt and Washer from the front of the Frame on the outer edge near the Bearing Housing (**Figure 23** on page 33).
5. Slide the Bottom Shield out from under the lip of the Side Shield and remove it.
6. When reinstalling the Bottom Shield, be sure to tuck it under the lip of the Side Shield first, then finish positioning it and install the mounting hardware.
7. Reinstall the Stone Guard Flap in the reverse order of the steps to remove it on page 33.

Bottom Shield - SELF-PROPELLED

! WARNING!

BEFORE PERFORMING ANY MAINTENANCE PROCEDURE OR INSPECTION, STOP THE ENGINE, WAIT FIVE (5) MINUTES TO ALLOW ALL PARTS COOL. DISCONNECT THE SPARK PLUG WIRE, KEEPING IT AWAY FROM THE SPARK PLUG.

Tools Needed:

- 7/16" Wrench or Socket
- 3/8" Wrench or Socket

NOTE: You do not need to remove the Side Shield or any of its hardware when removing the bottom shield.

1. Remove the Mow-Ball™ Support Assembly. See “Removing the Mow-Ball™ Support Assembly” on page 31.
2. Remove the two (2) mounting Bolts and Washers at the rear of the Frame and the single mounting Bolt and Washer near the center using a 7/16" Wrench or Socket (**Figure 24**).
3. Remove the fourth mounting Bolt and Washer from the front of the Frame on the outer edge near the Bearing Housing (**Figure 24**) using a 3/8" Wrench or Socket.
4. Remove the Bottom Shield by sliding it out from under the Side Shield and lifting it up and over the Bearing Housing (**Figure 24**).
5. Reinstall the Bottom Shield in the reverse order.

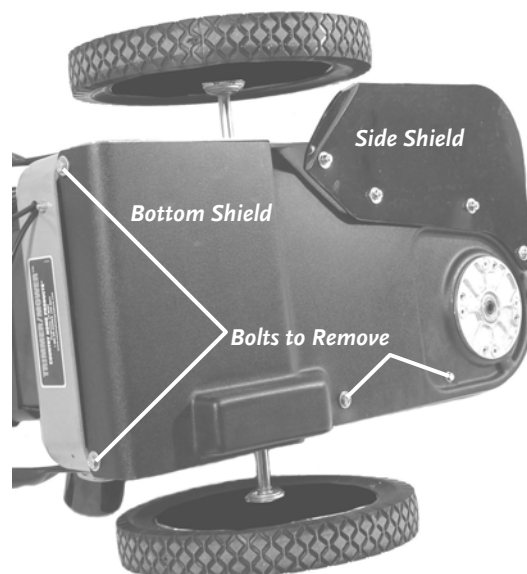

Trimmer Head Belt - All models

! WARNING!

BEFORE PERFORMING ANY MAINTENANCE PROCEDURE OR INSPECTION, STOP THE ENGINE, WAIT FIVE (5) MINUTES TO ALLOW ALL PARTS COOL. DISCONNECT THE SPARK PLUG WIRE, KEEPING IT AWAY FROM THE SPARK PLUG.

! NOTICE!

USE ONLY DR BELTS ON YOUR MACHINE. DO NOT USE HARDWARE STORE VARIETY BELTS.

Tools and Part Needed:

- 9/16" Wrench or Socket
- 3/16" Allen Wrench
- DR Drive Belt #114431

1. Remove the Mow-Ball™ Support Assembly. See “Removing the Mow-Ball™ Support Assembly” on page 31.
2. Remove the Stone Guard Flap. See “Removing the Stone Guard Flap” on page 33. This step is not applicable to the Self-Propelled model.
3. Remove the Bottom Shield. See “Bottom Shield” on page 33 or 34 depending on your model.
4. Remove the four (4) Allen set screws on the underside of the Lower Bearing Plate (**Figure 26**). The Lower Bearing should come off with the Plate (**Figure 27**).
5. Remove the Belt.
6. Install the new Belt. Be sure the Belt is on the inside of Idler Pulley #2, the outside of Idler Pulley #1 and correctly fitted around the Engine Pulley and in between the Engine Pulley Belt Guide (**Figure 25**).
7. Replace the Lower Bearing Plate, being sure to align the notch with the locking tool hole in the side of the Trimmer Housing and install the four (4) set screws in this order: Install one (1) set screw and make snug, then install and snug the set screw opposite it. Repeat for the remaining two (2) set screws.
8. Tighten all four (4) set screws in the same pattern. Do not over tighten.
9. Reinstall the Bottom Shield and Stone Guard Flap as applicable.
10. Reinstall the Mow-Ball™ Support Assembly.

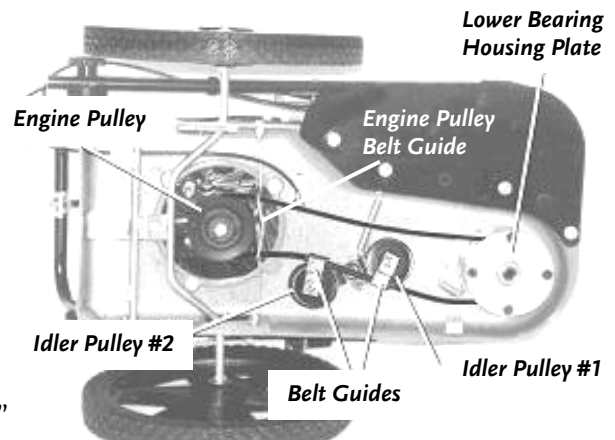

Figure 25

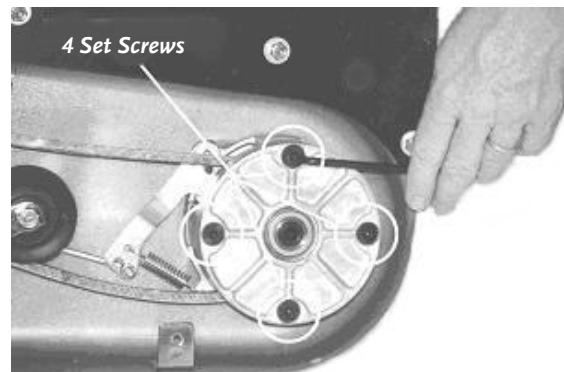

Figure 26

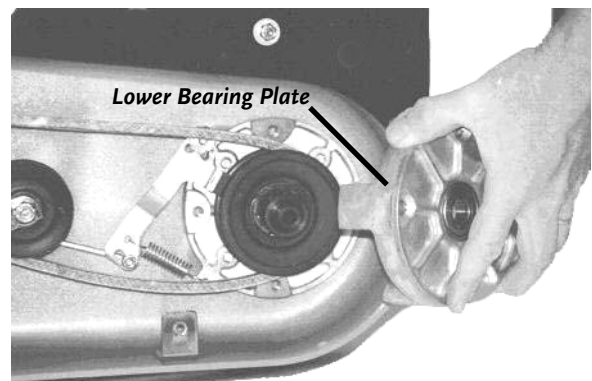

Figure 27

Drive Belt - SELF-PROPELLED

! WARNING!

BEFORE PERFORMING ANY MAINTENANCE PROCEDURE OR INSPECTION, STOP THE ENGINE, WAIT FIVE (5) MINUTES TO ALLOW ALL PARTS COOL. DISCONNECT THE SPARK PLUG WIRE, KEEPING IT AWAY FROM THE SPARK PLUG.

! NOTICE!

USE ONLY DR BELTS ON YOUR MACHINE. DO NOT USE HARDWARE STORE VARIETY BELTS.

Tools and Part Needed:

- 7/16" Wrench or Socket
- 3/8" Wrench or Socket
- DR Drive Belt #179581

1. Remove the Mow-Ball™ Support Assembly. See “Removing the Mow-Ball™ Support Assembly” on page 31.
2. Remove the Bottom Shield. See “Bottom Shield” on page 34.
3. Remove the Trimmer Head Belt from around the Engine Pulley. There is enough slack in the Belt to just peel the Belt from around the Pulley.
4. Grasp the Transmission Housing and rotate it out to loosen the Drive Belt (**Figure 28**). You can now remove the Belt from the Transmission Pulley and upper Engine Pulley. The Transmission Housing is spring loaded so it will return to its original position when released.
5. Install a new DR Drive Belt around the upper Engine Pulley, rotate the Transmission Housing out, and slip the Drive Belt around the Transmission Pulley. Allow the Housing to return to its resting position with the Belt in place.
6. Re-install the Trimmer Head Belt on the Lower Engine Pulley.
7. Re-install the Bottom Shield and the Mow-Ball™ Support Assembly.

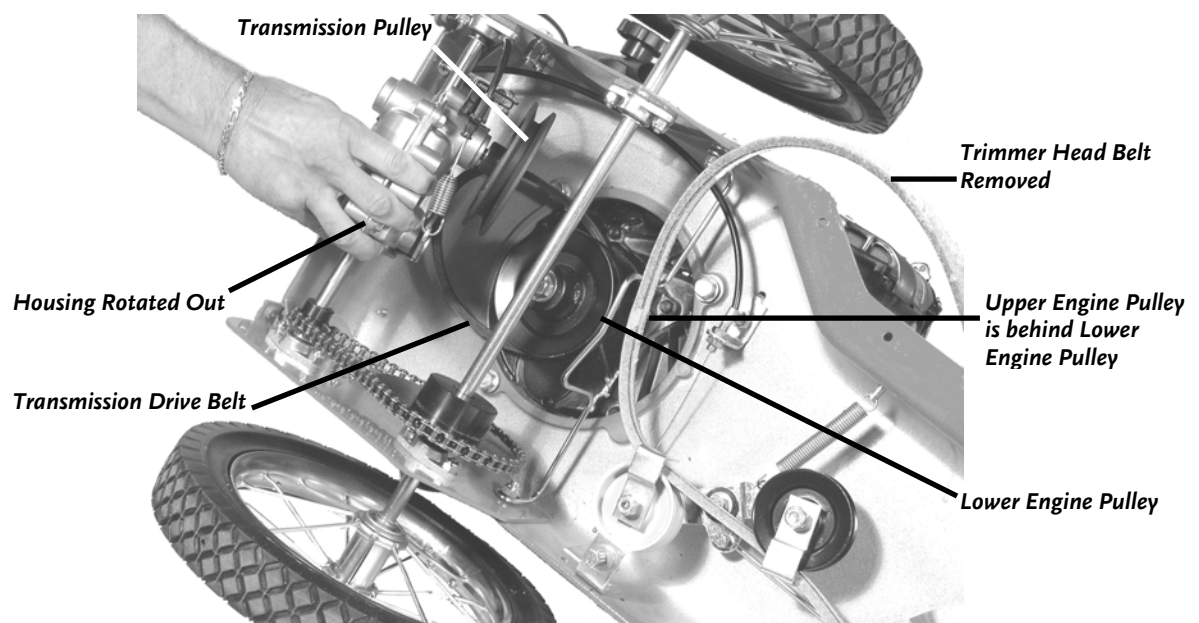

Brake Arm – All models

WARNING!

BEFORE PERFORMING ANY MAINTENANCE PROCEDURE OR INSPECTION, STOP THE ENGINE, WAIT FIVE (5) MINUTES TO ALLOW ALL PARTS COOL. DISCONNECT THE SPARK PLUG WIRE, KEEPING IT AWAY FROM THE SPARK PLUG.

NOTICE!

BEFORE REPLACING THE BRAKE ARM, CHECK THAT THE MOUNTING OF THE BELT IS ON THE CORRECT SIDE OF THE IDLER PULLEYS (SEE *FIGURE 25* ON PAGE 35), AND NOT FRAYED, WORN OR STRETCHED. ALSO, SEE ADJUSTING THE TRIMMER HEAD BELT TENSION THROUGH THE TRIMMER CONTROL CABLE ON PAGE 42.

Tools needed:

- 3/8" Socket
- 7/16" Wrench or Socket
- 1/2" Wrench or Socket

1. Remove the Mow-Ball™ Support Assembly. See “Removing the Mow-Ball™ Support Assembly” on page 31.
2. Remove the Stone Guard Flap. See “Removing the Stone Guard Flap” on page 33. This step is not applicable to the Self-Propelled model.
3. Remove the Bottom Shield. See “Bottom Shield” on page 33 or 34 depending on your model.
4. Using a 3/8" Socket, remove the Lock Nut from the Brake Actuator Rod and remove the Rod from the Brake Arm (*Figure 29*).
5. Using a 1/2" Wrench, remove the four (4) Mounting Bolts that retain the Bearing Housing from topside of the Trimmer Housing (*Figure 30*).
6. Turn the Bearing Assembly over to expose the Brake Arm Assembly and unhook the Tension Spring from the Brake Arm (*Figure 31*).
7. Remove the Phillips Screw (*Figure 31*) retaining the Brake Arm.
8. Install the new Brake Arm Assembly in the reverse order.

NOTE: When replacing the Brake Actuator Rod, do not tighten the Nut against the Brake Arm. Leave the Nut just loose enough to allow the Rod to slide freely in the Brake Arm slot.

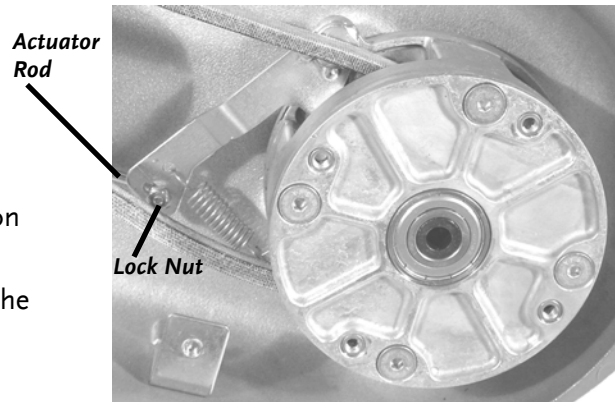

Figure 29

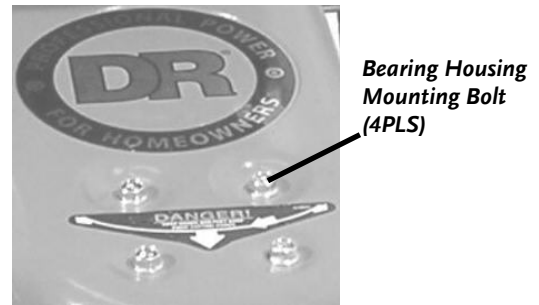

Figure 30

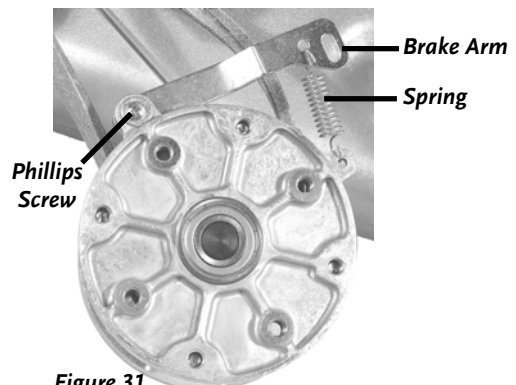

Figure 31

CALL TOLL-FREE 1-800-DR-OWNER

Side Shield - All models

! WARNING!

BEFORE PERFORMING ANY MAINTENANCE PROCEDURE OR INSPECTION, STOP THE ENGINE, WAIT FIVE (5) MINUTES TO ALLOW ALL PARTS COOL. DISCONNECT THE SPARK PLUG WIRE, KEEPING IT AWAY FROM THE SPARK PLUG.

! NOTICE!

YOU SHOULD NEVER OPERATE THE TRIMMER WITHOUT THE SIDE SHIELD IN PLACE. ALWAYS REPLACE A DAMAGED SIDE SHIELD IMMEDIATELY.

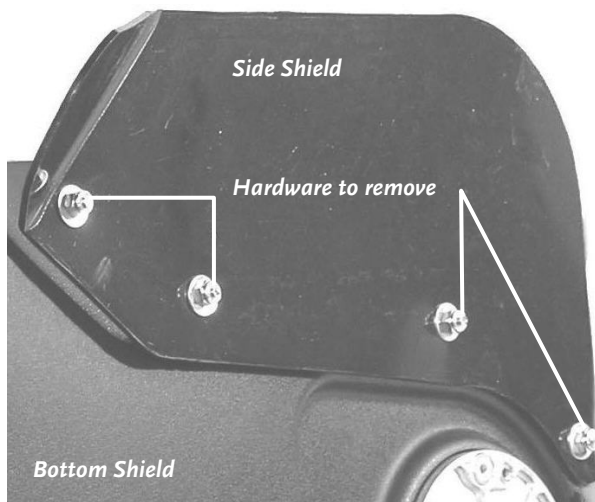

Figure 32

Tools needed:

- 3/8" Wrench or Socket
- 7/16" Wrench or Socket

1. Using a 3/8" Wrench or Socket (topside) and a 7/16" Wrench or Socket (underneath), remove the four (4) mounting Bolts, Nuts and Washers that retain the Side Shield and discard the old Shield.
2. Install the new Shield and secure in place with the mounting hardware.

Wheels - SPRINT[®], PRO and COMMERCIAL

! WARNING!

BEFORE PERFORMING ANY MAINTENANCE PROCEDURE OR INSPECTION, STOP THE ENGINE, WAIT FIVE (5) MINUTES TO ALLOW ALL PARTS COOL. DISCONNECT THE SPARK PLUG WIRE, KEEPING IT AWAY FROM THE SPARK PLUG.

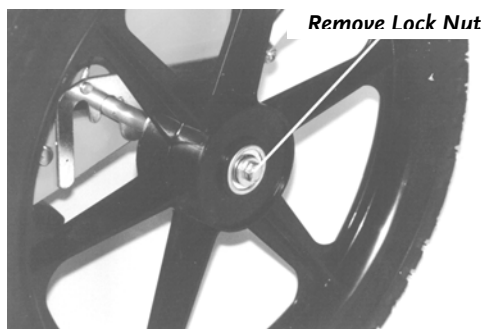

Figure 33

Tool needed:

- 5/8" wrench or socket

1. Block and stabilize the machine so that the wheels are off the ground.
2. Loosen and remove the Lock Nut. (**Figure 33**).
3. Slide the wheel off the axle.
4. Reverse the steps to install the wheel.

Wheels - SELF-PROPELLED

WARNING!

BEFORE PERFORMING ANY MAINTENANCE PROCEDURE OR INSPECTION, STOP THE ENGINE, WAIT FIVE (5) MINUTES TO ALLOW ALL PARTS COOL. DISCONNECT THE SPARK PLUG WIRE, KEEPING IT AWAY FROM THE SPARK PLUG.

NOTICE!

THE DESIGN OF YOUR TRIMMER IS TO POWER THE WHEELS IN THE FORWARD DIRECTION ONLY. READ AND FOLLOW THESE DIRECTIONS AND NOTES CAREFULLY WHEN INSTALLING A WHEEL.

Tool needed:

- 5/8" Wrench or Socket

1. Block and stabilize the machine so that the wheels are off the ground.
2. Loosen and remove the lock nut. (**Figure 34**).
3. Turn the wheel off the axle, clockwise for the right side wheel and counterclockwise for the left side wheel (left and right are determined from the operator's position).

NOTE: Remove and discard the red plastic retaining plug in the new wheel hub, just before installing the wheel.

4. To install a new wheel, place the wheel on the axle and slowly turn the wheel onto the axle (clockwise for the right side wheel and counterclockwise for the left side wheel from the operator's position).

NOTE: If the wheel will not turn onto the axle (locks against the axle) using the direction indicated in Step 4, simply turn the wheel around and try again. The black shield attached to the wheel should be on the inside.

5. Install the axle nut and tighten.

NOTE: The wheel is properly installed when the wheel will lock against the axle when you pull the Trimmer backward, and freewheels when pushed forward. The wheel bearings are designed to be directional.



Figure 34

Engine Oil - All models

! WARNING!

BEFORE PERFORMING ANY MAINTENANCE PROCEDURE OR INSPECTION, STOP THE ENGINE, WAIT FIVE (5) MINUTES TO ALLOW ALL PARTS COOL. DISCONNECT THE SPARK PLUG WIRE, KEEPING IT AWAY FROM THE SPARK PLUG.

! NOTICE!

- IF YOU HAVE THE COMMERCIAL OR SELF-PROPELLED MODEL, ALSO CHANGE THE OIL FILTER AT THIS TIME. SEE THE NEXT PAGE.
- **BE CERTAIN TO FILL WITH OIL BEFORE STARTING THE ENGINE. SEE PAGE 12.**

Tools and Supplies Recommended:

- SAE 30 HD Oil (refer to your Engine Owner's Manual for quantity required)
- Suitable container for used oil
- Rags
- Wooden pallet or workbench

NOTE: Drain the oil when the engine is warm. Warm oil drains quickly and completely.

1. For convenience, place the machine up on a wooden pallet or workbench.
2. Remove the Oil Filler Cap and position a suitable oil receptacle beside the Oil Fill Tube.
3. Make sure to securely tighten the Gas Fill Cap.
4. Using the handle of the DR TRIMMER/MOWER, tip the machine to the left and drain the oil out through the Oil Filler Tube into a suitable receptacle (**Figure 35**).
5. Refill the engine oil using SAE 30 HD oil to the level indicated on the dipstick. See page 12.
6. Reattach the spark plug wire.

NOTE: If you are not reusing the oil, be sure to use environmentally safe disposal procedures in the disposing of the used oil.

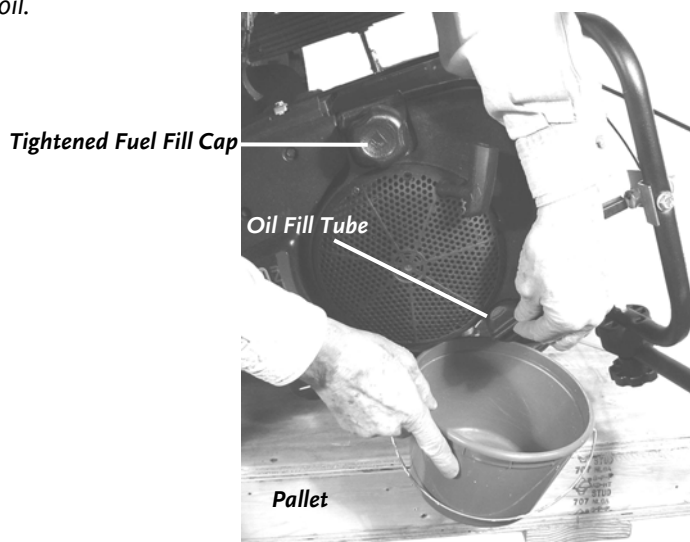

Figure 35

Engine Oil Filter - COMMERCIAL and SELF-PROPELLED

! WARNING!

BEFORE PERFORMING ANY MAINTENANCE PROCEDURE OR INSPECTION, STOP THE ENGINE, WAIT FIVE (5) MINUTES TO ALLOW ALL PARTS COOL. DISCONNECT THE SPARK PLUG WIRE, KEEPING IT AWAY FROM THE SPARK PLUG.

! NOTICE!

BE CERTAIN TO FILL WITH OIL BEFORE STARTING THE ENGINE. SEE PAGE 12.

Tools and Supplies Recommended:

- SAE 30 HD Oil (refer to your Engine Owner's Manual for quantity required)
- Oil Filter Wrench (obtainable from a local auto parts or hardware store)
- Suitable container for used oil
- Rags
- Wooden pallet or workbench

NOTE: Drain the oil when the engine is warm. Warm oil drains quickly and completely.

1. Remove the engine oil. See Engine Oil on the previous page.
2. Using an Oil Filter Wrench, or grasping the Oil Filter firmly with your hand, unscrew the Oil Filter counterclockwise from the engine (**Figure 36**). **BE SURE THAT THE OLD FILTER GASKET COMES OFF WITH THE OLD FILTER.**
3. Wipe the mounting base for the oil filter with a clean cloth.
4. Apply a thin coat of clean motor oil to the new Oil Filter Gasket. **DO NOT USE GREASE.**
5. Line up the threads carefully to avoid cross threading and screw the new Filter on until the Filter Gasket contacts the base, then tighten the Oil Filter 3/4 to 1 turn. **DO NOT OVER TIGHTEN.**
6. Refill the engine oil using SAE 30 HD oil to the level indicated on the dipstick. See page 12.
7. Reattach the spark plug wire.
8. Start the engine and check for oil leaks around the Filter base. Correct any oil leaks by simply tightening the Oil Filter 1/8 of a turn at a time.

NOTE: If you are not reusing the oil, be sure to use environmentally safe disposal procedures in the disposing of the used oil and the used oil filter.

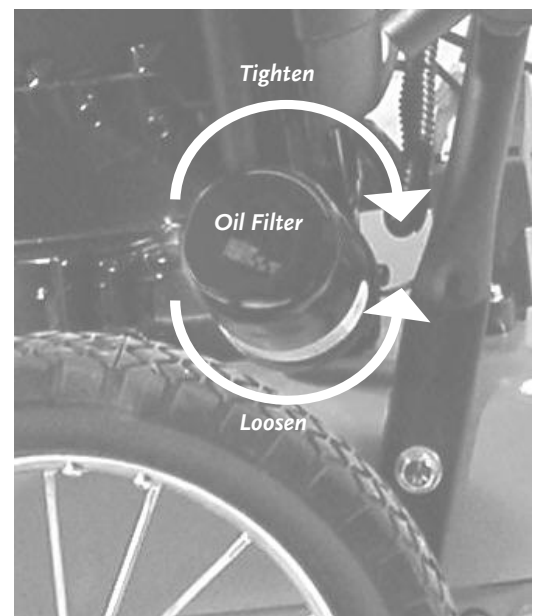

Figure 36

Adjusting the Trimmer Head Belt Tension through the Trimmer Control Cable - All models

! WARNING!

BEFORE PERFORMING ANY MAINTENANCE PROCEDURE OR INSPECTION, STOP THE ENGINE, WAIT FIVE (5) MINUTES TO ALLOW ALL PARTS COOL. DISCONNECT THE SPARK PLUG WIRE, KEEPING IT AWAY FROM THE SPARK PLUG.

! NOTICE!

BEFORE ADJUSTING THE TRIMMER CONTROL CABLE, CHECK THAT THE BELT MOUNTING IS ON THE CORRECT SIDE OF THE IDLER PULLEYS (SEE FIGURE 25 ON PAGE 35), AND NOT FRAYED, WORN OR STRETCHED. ALSO MAKE SURE THE SPRING IS ATTACHED TO THE BAIL BAR (FIGURE 37).

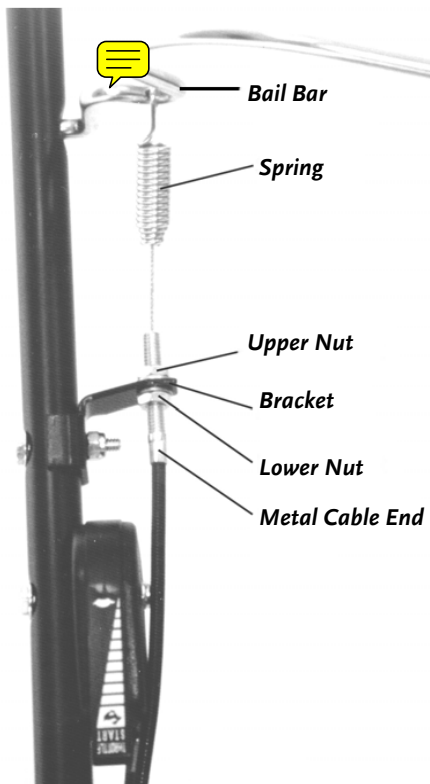

Figure 37

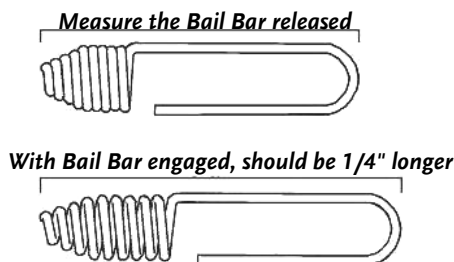

Figure 38

If the Trimmer Head stops spinning with the Bail Bar engaged and the machine is operating under a heavy load, the Belt may be too loose. In this case, you may need to adjust the Trimmer Control Cable to put more tension on it. The Adjuster is located on the right Handlebar, just above the Throttle Control Lever for the SPRINT[®], PRO, and COMMERCIAL models and on the left Handlebar for the SELF-PROPELLED model.

Tools needed:

- (2) 1/2" Open-end or Adjustable Wrench

To increase the tension on the belt:

1. Loosen the upper Control Cable Adjustment Nut, leaving about 1/8" of space between the Nut and Bracket (Figure 37).
2. Gently pull down on the Cable as you tighten the lower Nut until it is flush and snug against the Bracket (Figure 37).

NOTE: If the Trimmer Head still keeps spinning after releasing the Bail Bar, the Belt may be too tight or the Brake Arm may need replacing. See "Brake Arm" on page 37.

To decrease the tension on the belt:

1. Repeat the steps for increasing the tension on the Belt, but instead, loosen the Lower Nut first and then tighten the Upper Nut.

NOTE: To check your adjustment, measure the Spring with the Bail Bar disengaged. Then measure it with the Bail Bar engaged. There should be a 1/4" extension in the Spring when the Bail Bar is engaged (Figure 38). Adjust the Nuts on the Bracket as needed to get the correct measurements.

Adjusting the Wheel Clutch - SELF-PROPELLED

! WARNING!

BEFORE PERFORMING ANY MAINTENANCE PROCEDURE OR INSPECTION, STOP THE ENGINE, WAIT FIVE (5) MINUTES TO ALLOW ALL PARTS COOL. DISCONNECT THE SPARK PLUG WIRE, KEEPING IT AWAY FROM THE SPARK PLUG.

If the SELF-PROPELLED DR TRIMMER/MOWER will not drive forward when you squeeze the Wheel Clutch Lever or if the machine moves forward without the operator squeezing the Wheel Clutch Lever (or the machine “walks”), you will have to adjust the Wheel Clutch Cable.

If the machine will not drive forward:

Grasp the Lower Section of the Cable Adjuster with one hand and hold firmly. Turn the Upper Section of the Cable Adjuster clockwise so that the Adjuster is lengthening or turning apart. Make one revolution of the Adjuster at a time until the drive engages and disengages properly (**Figure 39**).

If the machine creeps ahead or “walks”:

Grasp the Lower Section of the Cable Adjuster with one hand and hold firmly. Turn the Upper Section of the Cable Adjuster counterclockwise so that the Adjuster is shortening or turning together. Make one revolution of the Adjuster at a time until the drive engages and disengages properly (**Figure 39**).

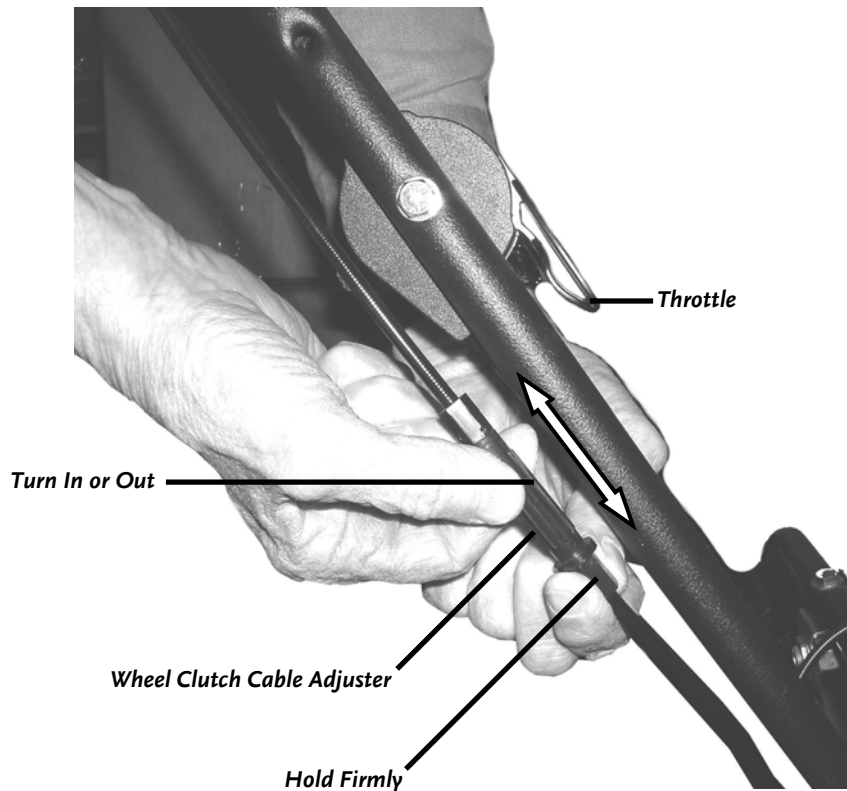

Figure 39

End of Season and Storage

WARNING!

- **BEFORE PERFORMING ANY MAINTENANCE PROCEDURE OR INSPECTION, STOP THE ENGINE, WAIT FIVE (5) MINUTES TO ALLOW ALL PARTS TO COOL. DISCONNECT THE SPARK PLUG WIRE, KEEPING IT AWAY FROM THE SPARK PLUG.**
- **NEVER STORE THE DR TRIMMER/MOWER WITH FUEL IN THE FUEL TANK INSIDE A BUILDING WHERE IGNITION SOURCES ARE PRESENT, SUCH AS HOT WATER AND SPACE HEATERS, CLOTHES DRYERS AND THE LIKE. IF YOU ARE GOING TO DRAIN THE FUEL TANK, DO THIS OUTDOORS. ALLOW THE ENGINE TO COOL BEFORE STORING IN ANY ENCLOSURE.**
- **WHEN NOT IN USE, YOUR DR TRIMMER/MOWER SHOULD BE STORED OUT OF THE REACH OF CHILDREN AND IN A DRY LOCATION.**

***NOTE:** Please refer to the Engine Owner's Manual for engine-specific procedures.*

- Check the Drive Belt(s) for wear.
- Change the Engine oil (and Oil Filter, if applicable). This will help to eliminate sludge and acids in the Engine.
- Remove the Spark Plug and pour about 1 ounce of motor oil into the cylinder hole. Reinstall the Plug and pull the Recoil Starter Rope until you feel strong resistance. This will coat the piston and seat the valves to prevent moisture buildup.
- Clean or replace the Engine Air Filters.
- Clean any dirt and debris from the cylinder head cooling fins, carburetor linkage, blower housing, debris screen, and muffler area of the Engine.
- Remove any wrapped weeds from the Mow-Ball™ Support, wheel spokes, and axles. Using a stiff brush, clean grass and debris from the top and underneath the Trimmer Deck.
- Remove the Bottom Shield and clean out any debris. See page 33 or 34.
- Check to make sure the operator controls are moving freely. Lubricate the Throttle Lever, PTA™ Lever (SPRINT®, PRO and COMMERCIAL models), and Key Switch with SAE 30 Oil if necessary.
- If your Engine has a fuel filter, replace it.
- If your DR TRIMMER/MOWER will be idle for more than 30 days, we recommend using a gas stabilizer. This will prevent sediment from gumming up the carburetor. If there is dirt or moisture in the gas or tank, remove it by draining the tank. Completely fill the tank with fresh, unleaded gas and add the appropriate amount of stabilizer or gasoline additive. Run the Engine for a short time to allow the additive to circulate.
- On Electric-Starting models, remove the Battery or store your DR TRIMMER/MOWER in a dry environment where the temperature is between -10° F (-23° C) and +85° F (+23° C). Make sure the storage temperatures will never be outside these limits.

TROUBLESHOOTING

Most problems are easy to fix. Consult the Troubleshooting Table below for common problems and their solutions. If you continue to experience problems, call Country Home Products, Inc. for support.

Troubleshooting Table



BEFORE PERFORMING ANY MAINTENANCE PROCEDURE OR INSPECTION, STOP THE ENGINE, WAIT FIVE (5) MINUTES TO ALLOW ALL PARTS TO COOL. DISCONNECT THE SPARK PLUG WIRE, KEEPING IT AWAY FROM THE SPARK PLUG.

SYMPTOM	POSSIBLE CAUSE
<p><i>Recoil will not pull out or is difficult to pull.</i></p>	<ul style="list-style-type: none"> ⇒ Check the Engine oil level, the Engine may be seized. ⇒ There may be an oil compression lock in the cylinder. Take out the Spark Plug; hold a rag over the Spark Plug hole and pull the Recoil Cord several times to blow out any oil in the cylinder. Wipe off the Spark Plug and reinstall it. ⇒ The Recoil may be broken or jammed. Try to turn the Engine pulley by hand, with the Spark Plug wire off. If it turns, the Recoil is broken or jammed. Call 1-800-DR-OWNER (376-9637) for assistance.
<p><i>The Engine will not start manually.</i></p> <p><i>(Please refer to the Engine Owner's Manual for Engine-specific procedures.)</i></p>	<ul style="list-style-type: none"> ⇒ Check for proper attachment of the Spark Plug wire. ⇒ Check that the Engine has the right amount of clean oil. If the oil is dirty, change it following the procedure on page 40. ⇒ A cold Engine should be primed. Push the Primer Bulb 3 to 5 times, releasing it completely each time. ⇒ You should be using fresh, clean, unleaded gas. If the gas is old, change it. Use a fuel stabilizer if you keep gas longer than one month. ⇒ Check the Fuel Filter (if equipped) to see if it is clear. Place a can under the Fuel Filter and remove the fuel line from the Engine side of the Filter. If gas flows freely, it is OK. ⇒ Check that the Air Filter is clean. If it is dirty, change it following the procedure in the Engine Owner's Manual. ⇒ Check that the Throttle is in the RUN position. Check the Throttle Cable and make sure that it is attached to the Engine and moving freely. ⇒ Make sure that the Spark Plug is clean. If the Spark Plug is dirty or cracked, change it. If it's oily, leave it out, hold a rag over the Spark Plug hole and pull the Recoil Cord several times to blow out any oil in the cylinder, then wipe off the Spark Plug and reinsert it. ⇒ If your Engine still will not start, call 1-800-DR-OWNER (376-9637) for assistance.

! WARNING!

BEFORE PERFORMING ANY MAINTENANCE PROCEDURE OR INSPECTION, STOP THE ENGINE, WAIT FIVE (5) MINUTES TO ALLOW ALL PARTS TO COOL. DISCONNECT THE SPARK PLUG WIRE, KEEPING IT AWAY FROM THE SPARK PLUG.

SYMPTOM	POSSIBLE CAUSE
<p><i>The Engine won't start using Electric-Start.</i></p> <p><i>(Please refer to the Engine Owner's manual for Engine-specific procedures.)</i></p>	<ul style="list-style-type: none"> ⇒ Check all of the items under the section called Electric Starting on page 18 and the previous section on Manual Starting. ⇒ Check the wiring behind the Key switch; it may have vibrated off the Switch terminals. ⇒ Check the wire connections - especially the ground connection, the large black wire coming from the Battery, where it connects to the Engine. ⇒ Check the wire connections to the Solenoid. Disconnect the black Battery ground wire first to avoid sparks. Check to be sure that all of the connections are clean and tight. Reconnect the Battery ground wire. ⇒ Check the ground connection on the Solenoid where it bolts to the Frame. Using a wrench or socket, tighten the Bolts to ensure a good connection to the Frame. ⇒ Make sure the Battery is charged. Check the voltage yourself or at a gas station. If it is low, charge it with a 12-volt, 1 to 2 Amp trickle charger. If you do not use your machine for at least 45 minutes at a time, the Battery may need to be periodically charged. See the Battery Care section on page 30. ⇒ If your Battery is charged and your DR TRIMMER/MOWER still won't start, call 1-800-DR-OWNER (376-9637) for assistance.
<p><i>The Engine lacks power or is not running smoothly.</i></p> <p><i>(Please refer to the Engine Owner's Manual for Engine-specific procedures.)</i></p>	<ul style="list-style-type: none"> ⇒ Check the Throttle travel. The Throttle Lever should be in the Run position. ⇒ Check for debris (hay seed, etc.) clogging the Air Filter Intake and clean out as required. ⇒ The blower housing, throttle linkage, and cooling fins should be free of debris. Clean them following the instructions in the Engine Owner's Manual. ⇒ The Air Filter should be clean. If it's dirty, change it following the procedure in the Engine Owner's Manual. ⇒ Remove the Spark Plug wire and dry the connection with a rag. ⇒ Check that the Spark Plug is clean. If it's fouled or cracked, change it. If it's oily, leave it out, hold a rag over the Spark Plug hole and pull the Recoil Cord several times to blow out any oil in the cylinder, then wipe off the Spark Plug and reinsert it. ⇒ You should be using fresh, clean, unleaded gas. If it is old, change it. Use a fuel stabilizer if you keep gas longer than one month. ⇒ Check that the Engine has the right amount of clean oil. If it is dirty, change it following the procedure on page 40. ⇒ If your Engine still lacks power, call 1-800-DR-OWNER (376-9637) for assistance.

! WARNING!

BEFORE PERFORMING ANY MAINTENANCE PROCEDURE OR INSPECTION, STOP THE ENGINE, WAIT FIVE (5) MINUTES TO ALLOW ALL PARTS TO COOL. DISCONNECT THE SPARK PLUG WIRE, KEEPING IT AWAY FROM THE SPARK PLUG.

SYMPTOM	POSSIBLE CAUSE
<i>Engine smokes.</i>	<ul style="list-style-type: none"> ⇒ Check the oil level and adjust as needed. ⇒ You may be operating the machine on too great an incline. (See SLOPES section on page 28) ⇒ Check the Air Filter and clean or replace if needed. ⇒ You may be using the wrong oil - too light for the temperature. Refer to your Engine Owner's Manual for detailed information. ⇒ Clean the Engine cooling fins and the carburetor housing if they are dirty. ⇒ If the Engine still smokes, call 1-800-DR-OWNER (376-9637) for assistance.
<i>The Trimmer Head won't spin or lacks power.</i>	<ul style="list-style-type: none"> ⇒ Check for proper alignment of the V-Belt. Check it against Figure 25 in the "Trimmer Head Belt-All Models" on page 35. ⇒ The Belt may be worn or frayed; if so, replace it. ⇒ If the Trimmer Head still will not spin, follow the procedure for "Adjusting the Belt Tension through the Trimmer Control Cable" on page 42. ⇒ If none of the above helps, call 1-800-DR-OWNER (376-9637) for assistance.
<i>The Trimmer Head keeps spinning or spins when you release the Bail Bar.</i>	<ul style="list-style-type: none"> ⇒ Check for proper alignment of the V-Belt. Check it against Figure 25 in the "Trimmer Head Belt-All Models" on page 35. ⇒ If the Trimmer Head keeps spinning when you release the Bail Bar, see "Adjusting the Belt Tension through the Trimmer Control Cable" on page 42. ⇒ Check the Brake for excessive wear and replace if necessary. See the "Brake Arm-All Models" on page 37. ⇒ If none of the above helps, call 1-800-DR-OWNER (376-9637) for assistance.
<i>The cutting Cords are breaking.</i>	<ul style="list-style-type: none"> ⇒ The Cords may be too dry. Store Cords in a plastic bag with a damp sponge or cloth to make them less prone to breaking or soak them in a bucket of water for a few days. ⇒ Try a lighter cord. ⇒ You may be trying to do too much too fast. Ease into the material you are cutting; let the Cord tips do the work. Take small bites of tall or tough vegetation. Cut half a swath at a time, keeping the cut area to the discharge or right side of the Trimmer. Go over tall material twice, the first time with the Trimmer Head tilted up and back; the second time with the Mow-Ball™ Support on the ground. ⇒ Make sure that you are not hitting the Cords against a stone or a chain-link fence. The Cords won't last as long against obstacles as in the open. Work on controlling the cutting pattern. With practice, you'll learn to cut closer to obstacles without hitting them. ⇒ If none of the above helps, call 1-800-DR-OWNER (376-9637) for assistance.

! WARNING!

BEFORE PERFORMING ANY MAINTENANCE PROCEDURE OR INSPECTION, STOP THE ENGINE, WAIT FIVE (5) MINUTES TO ALLOW ALL PARTS TO COOL. DISCONNECT THE SPARK PLUG WIRE, KEEPING IT AWAY FROM THE SPARK PLUG.

SYMPTOM	POSSIBLE CAUSE
<i>The cutting Cords are pulling out.</i>	<ul style="list-style-type: none"> ⇒ You may be moving too fast into tough, woody growth. In doing so, the Cords may wrap on stalks and pull out. Check the operating tips in the section above on breaking Cords. ⇒ Make sure that you are not trying to cut material too heavy for the Cord. The design of your Trimmer is to cut green material up to about the thickness of a pencil. For very heavy material, you may need the optional BEAVER BLADE® attachment. ⇒ Be sure that you are not installing the smaller Cord in the larger Cord slots. Please see page 23. ⇒ If none of the above helps, call 1-800-DR-OWNER (376-9637) for assistance.
<i>PTA™ (Parallel Trimming Action) is difficult.</i>	<ul style="list-style-type: none"> ⇒ If you have adjusted the Handlebar up or down, you may need to adjust the PTA™ lever. See the section “Adjusting the PTA™” on page 15. ⇒ If the above does not help, call 1-800-DR-OWNER (376-9637) for assistance.
<i>The Mow-Ball™ Support is wearing too quickly.</i>	<ul style="list-style-type: none"> ⇒ You may be pushing the Trimmer Head down into the ground. The DR TRIMMER/MOWER works best with a light touch, with the Mow-Ball™ Support resting easily on the ground. ⇒ You may be hitting the Mow-Ball™ Support against rocks, concrete driveways or other hard obstacles. Try approaching them slowly, and from different directions, to avoid unnecessary wear. ⇒ If none of the above helps, call 1-800-DR-OWNER (376-9637) for assistance.
<i>The Drive Wheels won't turn (SELF-PROPELLED model).</i>	<ul style="list-style-type: none"> ⇒ The Transmission Clutch may be out of adjustment. Adjust the Inline Adjuster located in the Clutch Cable. See “Adjusting the Wheel Clutch” on page 43. ⇒ The Drive Chain may have broken or come off the sprockets. Remove the Bottom Shield to investigate. See page 34. ⇒ The Drive Belt may have come off the pulleys, worn out or failed. Remove the Bottom Shield to investigate. See page 34 and Drive Belt on page 36. ⇒ Check to see if the Wheels rotate freely in each direction. They should freewheel in the forward direction and lock against the axle going backwards. If they freewheel backwards, the Drive Wheel Clutches may have failed. Call 1-800-DR-OWNER (376-9637) for assistance. ⇒ If none of the above helps, call 1-800-DR-OWNER (376-9637) for assistance.
<i>The machine creeps forward without squeezing the clutch (SELF-PROPELLED model).</i>	<ul style="list-style-type: none"> ⇒ The Transmission Clutch may be out of adjustment. Adjust the Inline Adjuster located in the Clutch Cable. See “Adjusting the Wheel Clutch” on page 43. ⇒ If the Trimmer still “creeps”, call 1-800-DR-OWNER (376-9637) for assistance.

PARTS LISTS, SCHEMATIC DIAGRAMS AND WARRANTY
Parts List - Handlebar Assembly - SPRINT[®], PRO and COMMERCIAL

NOTE: Part numbers listed are available through Country Home Products, Inc.

<u>Ref#</u>	<u>Part#</u>	<u>Description</u>	<u>Ref#</u>	<u>Part#</u>	<u>Description</u>
03	143971	Cable, Throttle, Reverse Throw, B&S	110	143901	Knob, Bracket, PTA [™] Lever
04	112381	Washer, Flat, 1/4", USS	112	143881	Lever, PTA [™]
05	113081	Ignition Switch, Key, E/S, w/805 Hardware	113	143891	Bracket, PTA [™] Lever, Handlebar
06	174561	Handlebar, Lower, Black	116	144001	Cable, PTA [™]
07	144641	Bolt, Carriage, 5/16"-18 x 3", GR 2, ZP	117	118691	Nut, Head Engage Cable
08	110761	Nut, Nylon Locking, 5/16"-18	<u>Not Illustrated</u>		
09	147551	Handlebar, Upper, Black	188241		Wire Harness, w/adapter, B&S
	179191	Handlebar, Upper, Black, w/Grip			
10	123361	Bolt, 5/16"-18 x 1-1/4", HCS, GR 5, ZP			
11	174531	Bracket, key switch			
12	110731	Nut, Nylon Locking, 1/4"-20			
13	101451	Bolt, 1/4"-20 x 1-1/2", HHCS, GR 2, ZP			
14	112371	Washer, Flat, #10, USS			
15	143681	Bracket, Cable, Trimmer Head Engage, Handlebar			
17	143671	Stop, Bail Bar			
18	165331	Grip, Handlebar, Foam			
19	143931	Spring, C, .720" OD x .063" Wire, Handlebar Adjuster			
20	143661	Knob, Handlebar, 5/16"-18			
21	191351	Handlebar Adjuster, Inside			
22	143731	Handlebar Adjuster, Outside			
22.1	145801	Handlebar Adjuster Assembly			
23	112141	Cable Tie, Nylon, Black, 7-1/2"			
25	114561	Bolt, 1/4"-20 x 2", HCS, GR 2, ZP			
26	143981	Cable, Trimmer Head Engage			
30	214661	O-Ring			
109	143651	Bail Bar			

Schematic - Handlebar Assembly - SPRINT[®], PRO and COMMERCIAL

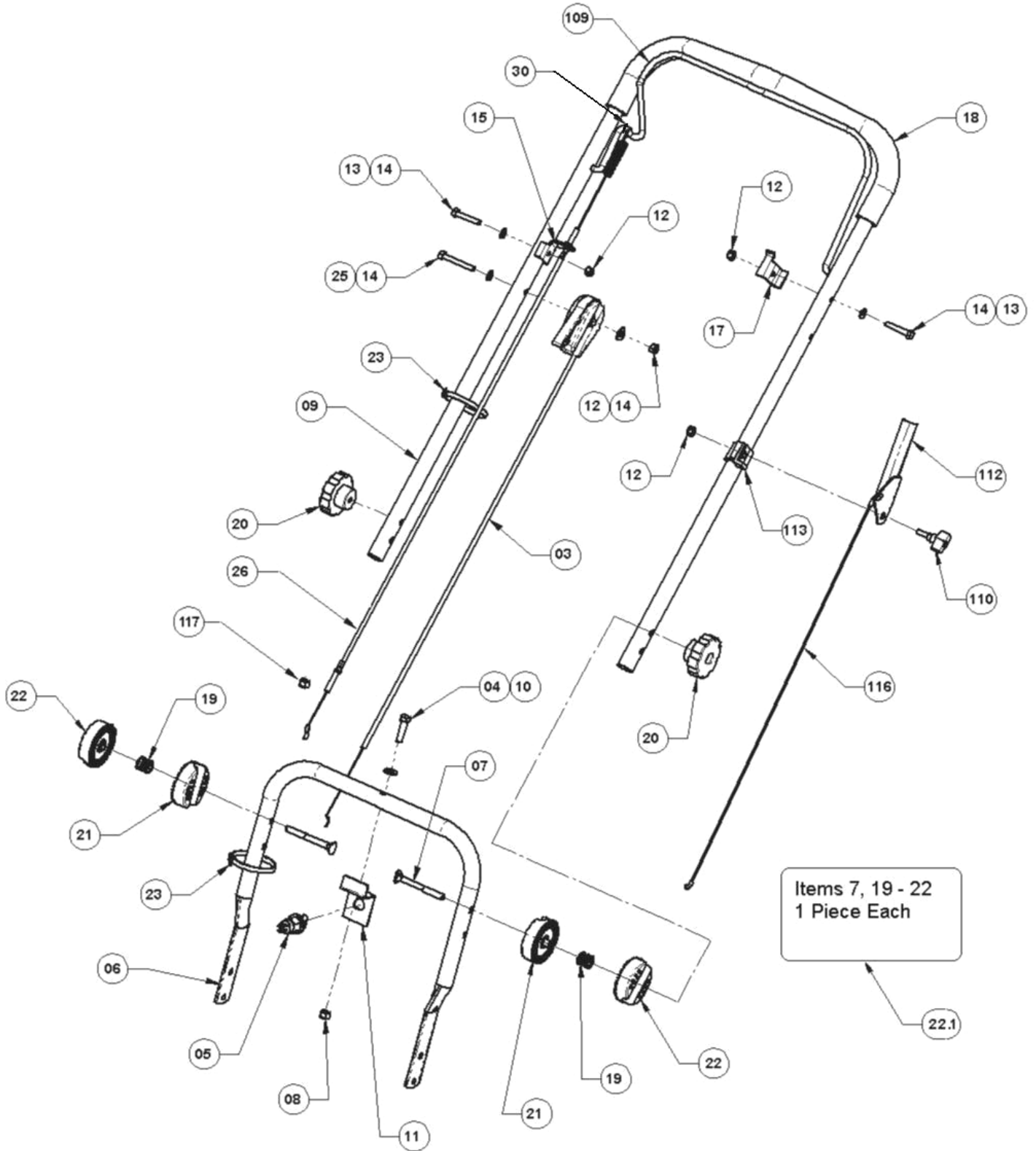

061213

Parts List - Axle Assembly - SPRINT[®], PRO and COMMERCIAL

NOTE: Part numbers listed are available through Country Home Products, Inc.

Ref#	Part#	Description
04	112381	Washer, Flat, 1/4", ZP
08	110761	Nut, Nylon Locking, 5/16"-18
49	151401	Bolt, 1/4"-20 x 3/4", Tri-Lobe (PRO, COMMERCIAL)
50	111581	Bolt, 5/16"-18 x 1", HHCS, GR 2, ZP
83	152331	Nut, Nylon Locking, 7/16"-20, Low Profile
84	147611	Wheel, 16", Black Nylon (PRO)
	147601	Wheel, 16", Chrome, Spoke (COMMERCIAL)
	190061	Wheel, 14", Black Resin, 6-Spoke (SPRINT)
101	143621	Arm, PTA [™] Locking
102	143611	Support, PTA [™] Spring
103	121521	Washer, Nylon, Axle, 3/4" x 3/8" x .020 Thick
104	144011	Spring, E, .500" OD x .075", wire
105	143841	Stud, Pivot
108	147501	Axle Assembly
111	143761	Pivot Support Assembly w/Rod

Schematic - Axle Assembly - SPRINT[®], PRO and COMMERCIAL

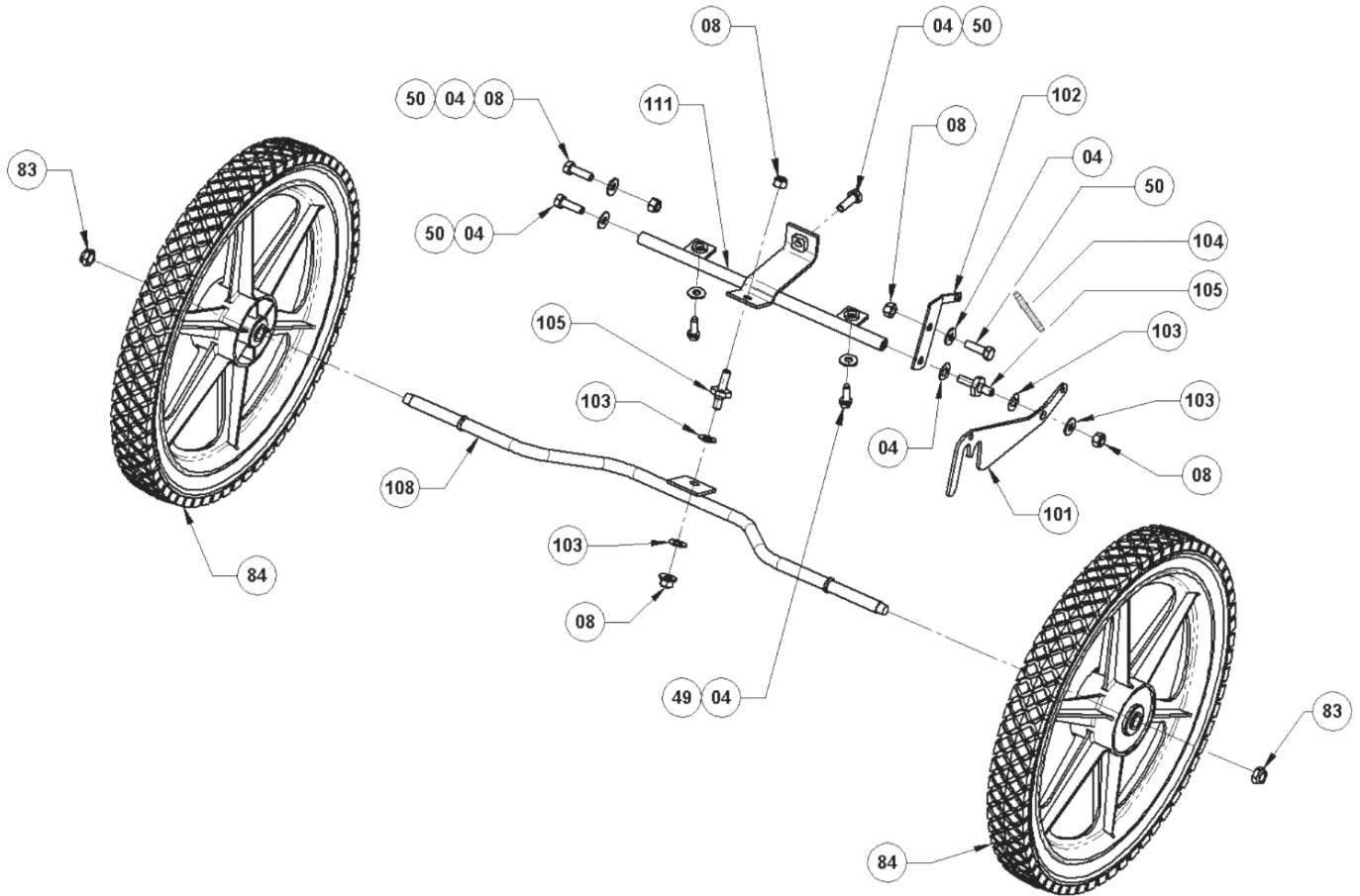

050919

Parts List - Main Frame Assembly - All Models

NOTE: Part numbers listed are available through Country Home Products, Inc.

<u>Ref#</u>	<u>Part#</u>	<u>Description</u>	<u>Ref#</u>	<u>Part#</u>	<u>Description</u>
04	112381	Washer, Flat, 1/4", USS	66	<u>COMMERCIAL and SELF-PROPELLED Models</u>	
08	110761	Nut, Nylon Locking, 5/16"-18	223821	Engine, 8.25 TQ, B&S, E/S	
12	110731	Nut, Nylon Locking, 1/4"-20	223421	Engine, 8.25 TQ, B&S, E/S, CA	
28	147521	Frame, Drilled, Aluminum, Orange (PRO, COMMERCIAL)	67	114921 Bracket, Belt Retainer	
	190071	Frame, Steel, Orange (SPRINT)	68	118731 Nut, Nylon Locking, 10-24	
	180421	Frame, Drilled, Aluminum, Orange (SELF-PROPELLED)	69	143831 Bracket, Clutch, Deck	
45	180811	Washer, Lock, 3/8"	70	113071 Pulley, Idler #1, 2-1/4" Diameter	
47	111551	Bolt, 3/8"-24 x 3/4", HHCS, GR 2, ZP	71	143521 Rod, Brake Connecting	
49	151401	Screw, 1/4"-20 x 3/4", Tri-Lobe, ZP	72	134431 Bolt, 5/16"-18 x 1-1/2" HCS	
50	111581	Bolt, 5/16"-18 x 1", HHCS, GR 2, ZP	73	143751 Washer, Nylon, .505" ID x 1" OD	
51	143941	Spring, Ext., .50" OD x .063" Wire	74	143601 Stand-off, Clutch Arm	
52	114431	V-Belt, 1/2" x 45", 4L450	75	143581 Arm, Clutch	
53	110751	Nut, Nylon Locking, 3/8"-16	85	146801 Guide, Engine Pulley, Belt (PRO, COMMERCIAL, SELF-PROPELLED)	
54	144091	Pulley, Idler #2, 2-5/8" OD		143821 Guide, Engine Pulley, Belt (Sprint)	
55	143771	Shield, Outer, Lower	98	152501 Bolt, 1/4"-20 x 3/4" HCS	
56	119191	Pulley 4", V-Belt	99	146821 Rod, Debris Guard (PRO, COMMERCIAL)	
58	145221	Screw, 3/8"-16 x 1-1/2", HHCS (PRO, COMMERCIAL)		143791 Rod, Debris Guard (SPRINT)	
60	146811	Clip, Mounting, Inner Lower Shield, (PRO, COMMERCIAL, SELF-PROPELLED)	100	147581 Screw, 10-24 x 1/2", Type B (PRO, COMMERCIAL)	
	143801	Clip, Mounting, Inner Lower Shield, (SPRINT)		144511 Bolt, Carriage, 10-24 x 5/8" (SPRINT – used with item 68)	
61	146781	Shield, Inner, Lower, aluminum (PRO, COMMERCIAL)	107	143781 Debris Guard (SPRINT, PRO, COMMERCIAL)	
	143811	Shield, Inner, Lower, steel (SPRINT)	114	152141 Rivet, Ratchet, 1/4" OD (PRO, COMMERCIAL, SELF-PROPELLED)	
	179511	Shield, Bottom (SELF-PROPELLED)	115	146791 Wear Strip (PRO, COMMERCIAL)	
62	180131	Bolt, 1/4"-20 x 1", Tri-Lobe, ZP	<u>Not Illustrated:</u>		
63	143871	Battery, 12 V, 2.9 Ah		114681 Bolt, 1/4"-20 x 1-1/4" HCS	
64	143861	Pad, Battery, 1.38" x 7.0"		100771 E-Clip, Clutch Cable (PRO, COMMERCIAL, SPRINT)	
65	143851	Clamp, Battery, Plastic		152361 Tool, head locking	
66	<u>PRO and SPRINT Models</u>		<u>Labels</u>		
	224161	Engine, 6.5 TQ, B&S, M/S		127811 Warning, Add Oil	
	224151	Engine, 6.5 TQ, B&S, E/S		136491 Danger	
	223591	Engine, 6.5 TQ, B&S, E/S, CA		148221 Danger Head Rotation	
	223601	Engine, 6.5 TQ, B&S, M/S, CA		148231 Safety Icons	
				148241 Name, TR2 (PRO, COMMERCIAL, SPRINT)	
				153071 PTA (PRO, COMMERCIAL, SPRINT)	
				153081 Bail Bar	
				193201 Start, Key Bracket	

Schematic - Main Frame Assembly - All Models

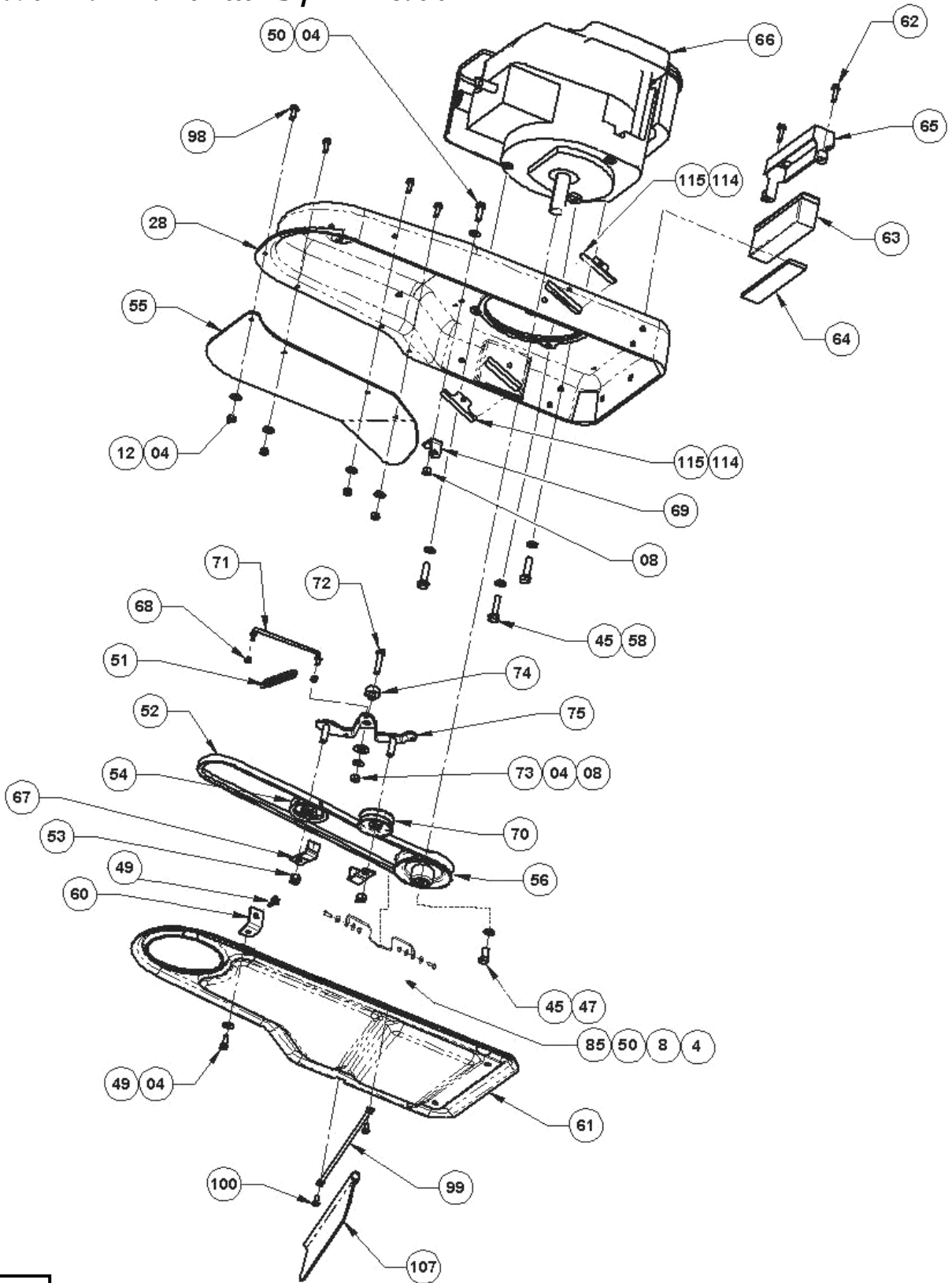

061212

Parts List - Handlebar Assembly - SELF- PROPELLED

NOTE: Part numbers listed are available through Country Home Products, Inc.

Ref#	Part#	Description
03	143971	Cable, Throttle, Reverse Throw, B&S
04	112381	Washer, Flat, 1/4" USS
05	113081	Ignition Switch, Key, E/S, w/805 Hardware
06	174561	Handlebar, Lower, Black
07	144641	Bolt, Carriage, 5/16"-18 x 3", GR 2, ZP
08	110761	Nut, Nylon Lock, 5/16"-18
09	147551	Handlebar, Upper, Black
09.1	191911	Handlebar, Upper, Black, w/Grip
10	123361	Bolt, 5/16"-18 x 1-1/4", HHCS, GR 5, ZP
11	174531	Bracket, Key Switch, E/S
12	110731	Nut, Nylon Lock, 1/4"-20
13	101451	Bolt, 1/4"-20 x 1-1/2", HHCS, GR 2, ZP
14	112371	Washer, Flat, #10, USS
15	143681	Bracket, Cable, Trimmer Head Engage, Handlebar
16	189721	Bail Bar
17	143671	Stop, Bail Bar
18	190471	Grip, Handlebar, Textured Vinyl, 18-3/4" Long
19	143931	Spring, C, .720" OD x .063" Wire, Handlebar Adjuster
20	143661	Knob, Handlebar, 5/16"-18
21	191351	Adjuster, Handlebar, Inside
22	143731	Adjuster, Handlebar, Outside
22.1	145801	Adjuster Assembly, Handlebar
23	112141	Tie, Cable, 7-1/2" Long, Black
24	179641	Cable, Transmission
25	114561	Bolt, 1/4"-20 x 2.0", HCS
26	190011	Cable, Trimmer Head Engage
27	179651	Lever, Transmission Engage
28	214661	O-Ring

Not Illustrated:

188241 Wire Harness, w/adaptor

Schematic - Handlebar Assembly - SELF- PROPELLED

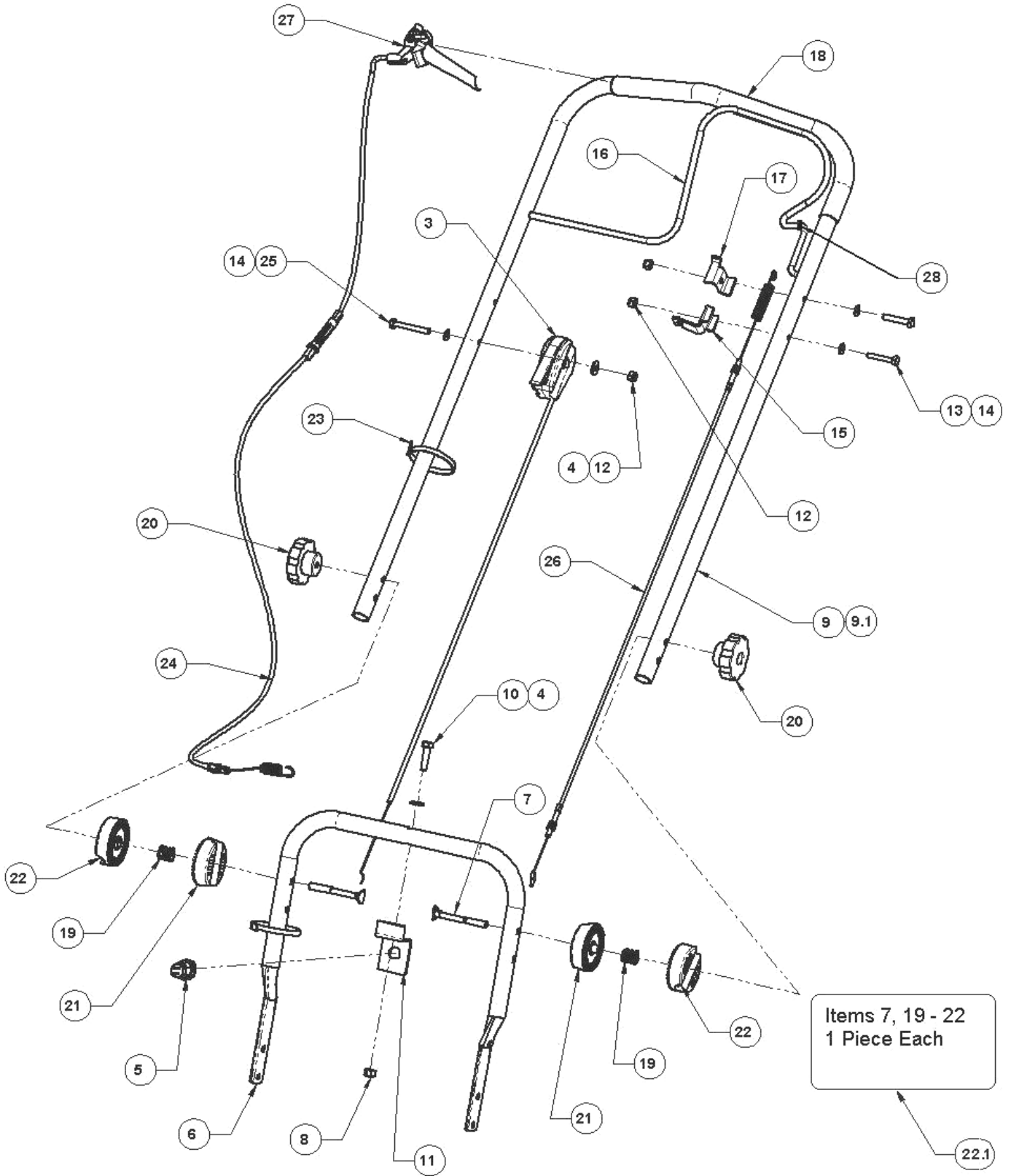

061213

CALL TOLL-FREE 1-800-DR-OWNER

Parts List - Axle Assembly - SELF-PROPELLED

NOTE: Part numbers listed are available through Country Home Products, Inc.

<u>Ref#</u>	<u>Part#</u>	<u>Description</u>
01	190531	Cover, Inner, Wheel
02	190541	Sleeve, Axle
04	112381	Washer, Flat, 1/4" USS
08	110761	Nut, Nylon Lock, 5/16"-18
12	110731	Nut, Nylon Lock, 1/4"-20
14	112371	Washer, Flat, #10, USS
46	179581	Belt, Transmission Drive, 3/8" x 20"
50	111581	Bolt, 5/16"-18 x 1" HCS
57	175601	Pulley, Transmission Drive, 2-3/4"
68	118731	Nut, Nylon, Lock, 10-24
76	193801	Transmission, 3 Speeds Forward
77	189791	Ring, Retaining, 10mm x 1" Thick
78	112441	Washer, .50" ID x .75" OD x .125" Thick, Nylon
79	179121	Screw, 1/4"-20 x 1/2", Tri-Lobe
80	213101	Ring, Retaining, .5" Shaft
82	179611	Clutch, Wheel
83	152331	Nut, Nylon, Lock, 7/16"-20, Low Profile
84.1	192381	Wheel Kit, Left, Sub Assembly, w/Item 01
84.2	192371	Wheel Kit, Right, Sub Assembly, w/Item 01
86	193811	Sprocket, Transmission, 10 Tooth
87	189591	Spring, Ext., Transmission Tension
88	179631	Bracket, Anti-Rotation
89	179591	Pulley, Transmission, 4"
90	119831	Bolt, 1/4"-20 x 3/4" HCS
91	179551	Bearing, w/Flange
92	175521	Bolt, Eye, 10-24 x 1/2"
93	193791	Axle, w/Woodruff Key
94	193821	Sprocket, Wheel, 40 tooth
95	179681	Plate, Axle, Mounting, Left
96	180841	Plate, Axle, Mounting, Right
97	179621	Chain, #35, 57 Links plus Master Link
99	213181	Key, Woodruff, 1/8" x 1/2"

Not Illustrated

189581 Key, Woodruff, 5/32" x 5/8"

Schematic - Axle Assembly - SELF-PROPELLED

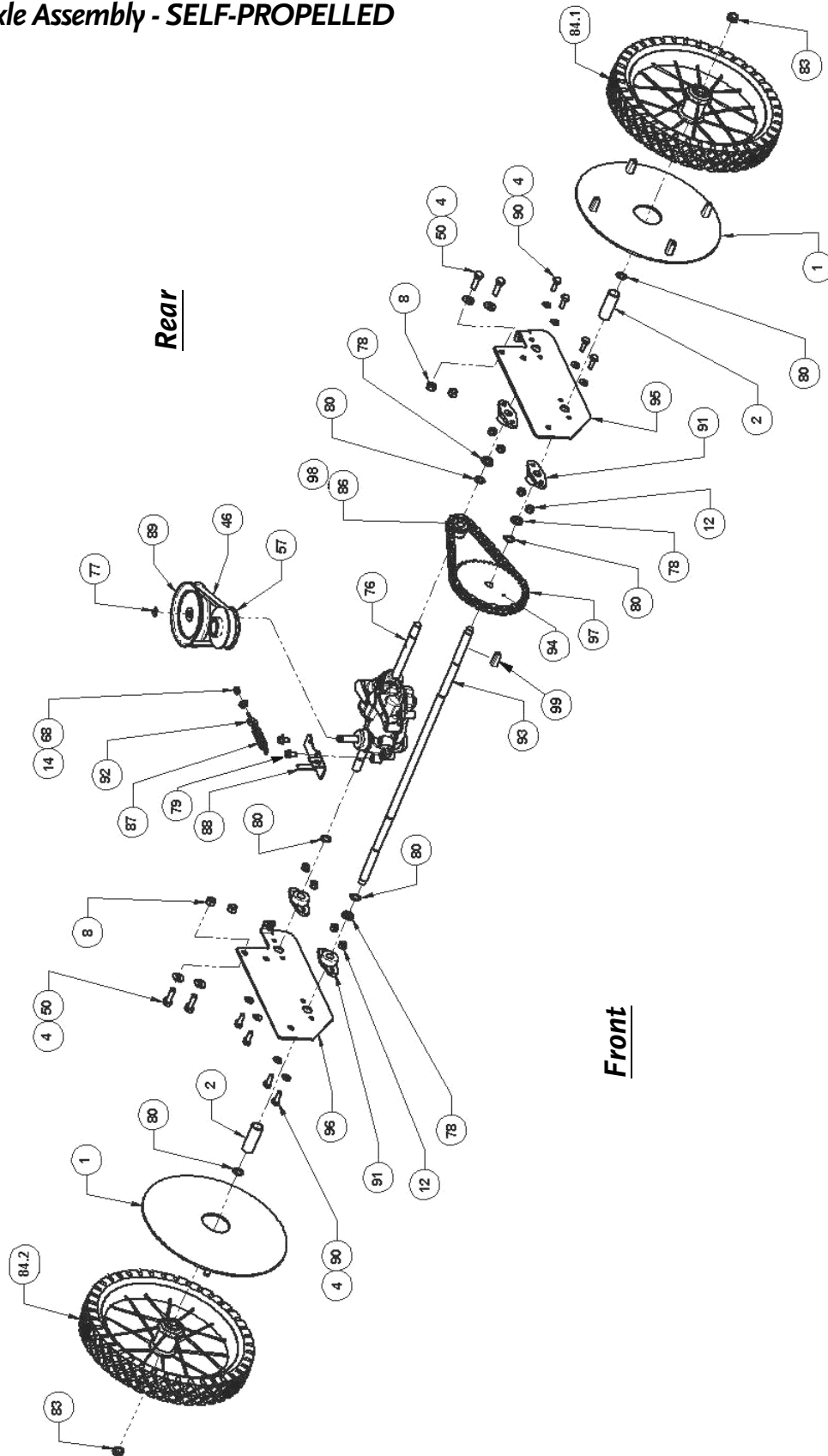

060328

Parts List - Mow Ball™ Assembly - All Models

NOTE: Part numbers listed are available through Country Home Products, Inc.

<u>Ref#</u>	<u>Part#</u>	<u>Description</u>
14	112371	Washer, Flat, #10 USS
30	213081	Bolt, Flat Head, 5/16"-18 x 2.75" w/Patch
31	143991	Spring, Ext., .500" OD x .049" Wire, Brake Return
32	143511	Brake Arm Assembly
33	121521	Washer, Axle, .750" OD x .380" ID
34	114781	Screw, Pan Head, 10-24 x 5/8", Slotted, GR 2
35	143501	Plate, Bearing, Lower, w/Bearing and Inserts
35.1	164111	Insert, 1/4"-20, Round
36	143491	Plate, Bearing, Upper
37	143921	Bearing, Ball, w/Snap Ring
38	143531	Pulley, V-Belt, 3-1/2"
39	144631	Bolt, 3/8"-16 x 4-3/4", HHCS, GR 5, ZP
40	144101	Mow Ball™, Nylon
41	143571	Plate, Line Spacer
42	143551	Standoff, Line Spacer Plate, T
43	143541	Plate, Back-Up
44	144701	Bolt, Serrated Flange, 5/16"-18 x 3/4", HHCS, GR 5, ZP
118	147181	Bearing Housing Assembly w/Brake and Belt
119	160321	Head Assembly, Complete
REF	145311	Cord, 23" long, .130ml, Orange

Schematic - Mow Ball™ Assembly - All Models

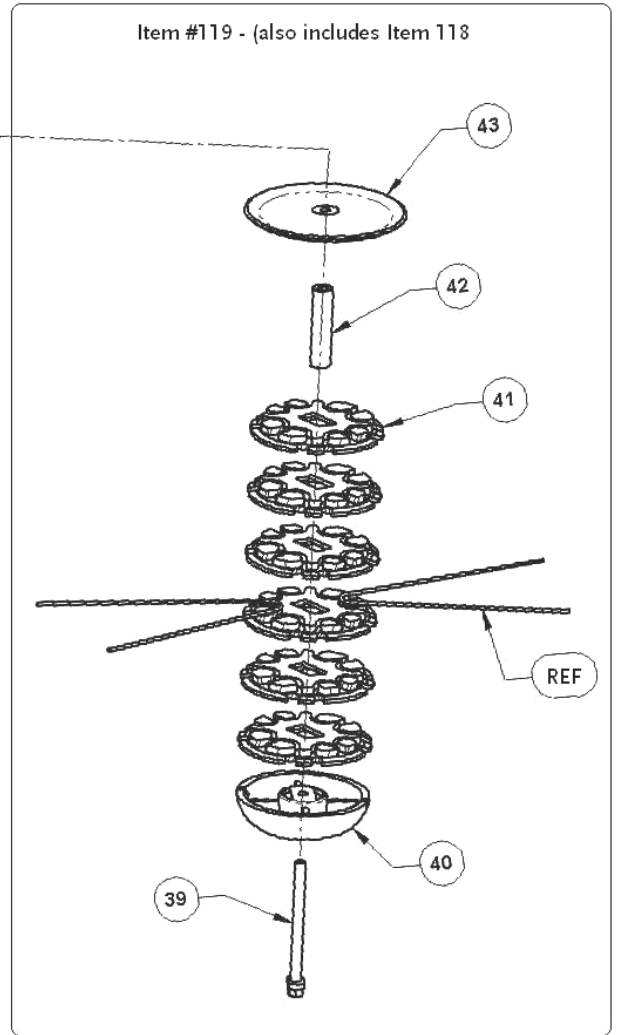
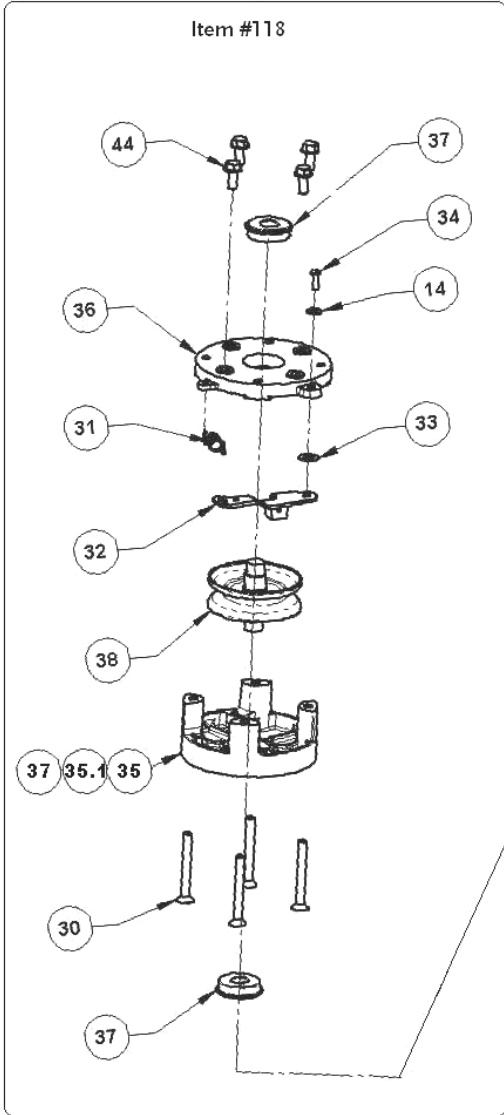

060327

Notes

DR[®] TRIMMER/MOWER



2-Year Limited Warranty

Terms and Conditions

The DR[®] TRIMMER/MOWER is warranted for two (2) years against defects in materials or workmanship when put to ordinary and normal consumer use; ninety (90) days for any other use. The engine manufacturer warrants the engine separately.

For the purposes of all the above warranties, "ordinary and normal consumer use" refers to non-commercial residential use and does not include misuse, accidents, or damage due to inadequate maintenance.

Country Home Products, Inc. (home of DR[®] Power Equipment) certifies that the DR[®] TRIMMER/MOWER is fit for ordinary purposes for which a product of this type is used. Country Home Products, Inc. however, limits the implied warranties of merchantability and fitness in duration to a period of two (2) years in consumer use, ninety (90) days for any other use.

The 2-Year Limited Warranty on the DR[®] TRIMMER/MOWER starts on the date the machine ships from our factory. The 2-Year Limited Warranty is applicable only to the original owner.

The warranty holder is responsible for the performance of the required maintenance as defined by the manufacturer's owner's manuals. The warranty holder is responsible for replacement of normally wearing parts such as the Drive Belt(s), Cutting Cords, Filters, Mow-Ball™ Support, Battery, Debris Shield, and Spark Plug. Attachments and accessories to the machine are not covered by this warranty.

During the warranty period, the warranty holder is responsible for the machine transportation charges, if required. During the warranty period, warranty parts will ship by standard method at no charge to the warranty holder. Expedited shipping of warranty parts is the responsibility of the warranty holder.

SOME STATES DO NOT ALLOW LIMITATIONS ON THE LENGTH OF IMPLIED WARRANTIES, SO THE ABOVE LIMITATIONS MAY NOT APPLY TO YOU.

Country Home Products, Inc. shall not be liable under any circumstances for any **incidental or consequential damages or expenses** of any kind, including, but not limited to, cost of equipment rentals, loss of profit, or cost of hiring services to perform tasks normally performed by the DR[®] TRIMMER/MOWER.

SOME STATES DO NOT ALLOW THE EXCLUSION OR LIMITATION OF INCIDENTAL OR CONSEQUENTIAL DAMAGES, SO THE ABOVE LIMITATIONS MAY NOT APPLY TO YOU.

Customer Service Hotline

Country Home Products, Inc.'s objective is to have 100% satisfied customers. For that reason, we operate a 6-day-a-week Technical Service Department for our Owners. You can access a Representative by dialing our TOLL-FREE Hotline at **1-800-DR-OWNER (376-9637)**. The sole job of our well-trained and friendly folks is to ensure that you get any help you need in a timely fashion. They are there to answer all your questions including: (1) inquiries on any of the above warranties, (2) inquiries about replacement parts, or (3) your questions regarding service, maintenance, and operation.

Our Customer Service Representatives will also be happy to answer any of your questions regarding the separate warranties on all engines. However, to obtain service, repair, or replacement of any engine within the period covered by the manufacturer's limited warranty, follow the instructions and warranty information specifically pertaining to those items provided by their separate manufacturers.

THIS WARRANTY GIVES YOU SPECIFIC LEGAL RIGHTS, AND YOU HAVE OTHER RIGHTS, WHICH VARY FROM STATE TO STATE.

Daily Checklist for the DR TRIMMER/MOWER

To help maintain your DR TRIMMER/MOWER for optimum performance, we recommend you follow this checklist each time you use your machine.

- [] OIL: With the machine on a level surface, check the engine oil level with the dipstick and add more if necessary (only add oil to the level indicated on the dipstick - DO NOT OVERFILL). Use SAE 30 high detergent motor oil.
- [] GAS: Fill the gas tank with clean, fresh, unleaded gasoline.
- [] ENGINE AIR COOLING SYSTEM: It is very important to keep the engine clean of debris. Remove grass and other built-up materials from the air intake screen before, during, and after you mow. Regularly remove debris from the blower housing and cooling fins. A dirty engine retains heat and can cause damage to the internal engine parts.
- [] CUTTING CORDS: Replace broken or frayed Cords.
- [] MOW-BALL™ SUPPORT and LINE PLATES: Check the Mow-Ball™ Support and Line Plates for wear and replace as needed.
- [] GENERAL CONDITION: Check the general condition of the machine, e.g.; nuts, bolts, welds etc.



COUNTRY HOME PRODUCTS, Inc.

MEIGS ROAD, P.O. BOX 25, VERGENNES, VERMONT 05491

1-800-DR-OWNER (376-9637) • www.dr-owner.com

©2007 CHP, Inc. 223641