

**DR<sup>®</sup> VERSA TRAILER™**

**SAFETY & OPERATING INSTRUCTIONS**

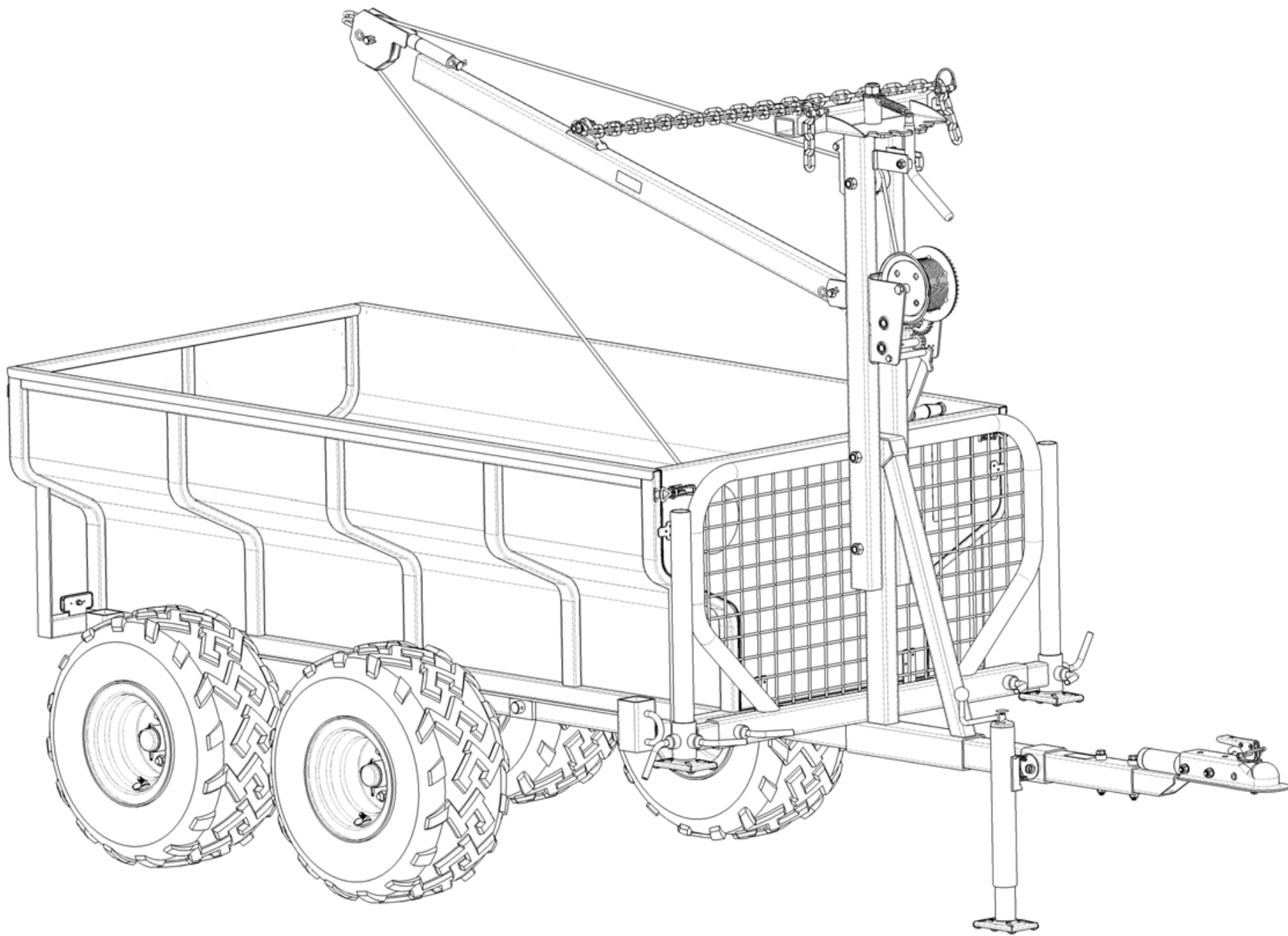

Serial No. \_\_\_\_\_  
Order No. \_\_\_\_\_

**Original Language**

DR Power Equipment  
Toll-free phone: 1-800-DR-OWNER (376-9637)  
Fax: 1-802-877-1213  
Website: [www.DRpower.com](http://www.DRpower.com)

**⚠ WARNING**

Read and understand this manual and all instructions before assembling and operating the DR VERSA TRAILER.

## Table of Contents

Chapter 1: General Safety Rules.....	3
Chapter 2: Assembling The DR VERSA TRAILER .....	6
Chapter 3: Operating The DR VERSA TRAILER.....	20
Chapter 4: Maintaining The DR VERSA TRAILER .....	25
Chapter 5: Troubleshooting .....	27
Chapter 6: Parts Lists and Schematic Diagrams .....	30

### Conventions used in this manual

---

#### **WARNING**

This indicates a hazardous situation, which, if not avoided, **could** result in death or serious injury.

---

---

#### **CAUTION**

This indicates a hazardous situation, which, if not avoided, **could** result in minor or moderate injury.

---

---

#### **NOTICE**

This information is important in the proper use of your trailer. Failure to follow this instruction could result in damage to your Trailer or property.

---

**TIP:** This is a helpful hint to guide you in getting the most out of your DR VERSA TRAILER.

**NOTE:** *This information may be helpful to you in using your DR VERSA TRAILER.*

### Serial Number and Order Number

A Serial Number is used to identify your Trailer and is located on the Serial Number Label on the Main Frame of your Trailer. An Order Number is used to check and maintain your order history and is located on the upper left portion of your packing slip. For your convenience and ready reference, enter the Serial Number and Order Number in the space provided on the front cover of this manual.

### Additional Information and Potential Changes

DR Power Equipment reserves the right to discontinue, change, and improve its products at any time without notice or obligation to the purchaser. The descriptions and specifications contained in this manual were in effect at printing. Equipment described within this manual may be optional. Some illustrations may not be applicable to your Trailer.

## Chapter 1: General Safety Rules

### **WARNING**

Read this Safety & Operating Instructions Manual before you assemble and use the DR VERSA TRAILER. Become familiar with the operation and service recommendations to ensure the best performance from your Trailer. If you have any questions or need assistance, please contact us at [www.DRpower.com](http://www.DRpower.com) or call Toll-Free 1-800-DR-OWNER (376-9637) and one of our Technical Support Representatives will be happy to help you.

### **Labels**

Your DR VERSA TRAILER carries prominent labels as reminders for its proper and safe use. Shown below are copies of all the Safety and Information Labels that appear on the unit. Take a moment to study them and make a note of their location on your DR VERSA TRAILER as you set up and before use of your Trailer. Replace damaged or missing Safety and Information labels immediately.

### **WARNING!**

#### **AVOID SERIOUS INJURY OR DEATH**

- Read and understand owner's manual before using this trailer or the winch. Do not allow the use of the trailer by anyone not familiar or unable to understand the instructions.
- Do not operate under the influence of drugs or alcohol, or if mentally or physically impaired.
- Inspect winch cable (wire rope) and hook before each use and do not use until cable is replaced if there is any damage, crimping, or fraying of the cable.
- Wear safety glasses and gloves when operating the winch.
- Do not stand behind the winch in line with the cable when operating. If cable breaks it may snap and whip back.
- Check the towing capacity of the towing vehicle before use. Do not exceed the stated capacity of the towing vehicle.
- Never exceed the weight limitations of the trailer.
  - Max towing capacity 2000 pounds
  - Max dumping capacity 650 pounds
  - Max lifting capacity 440 pounds
- Never exceed the maximum towing speed of 25 mph.
- Do not operate near dangerous slopes or on slopes over 20 degrees.
- Be sure latches are secure on end panels when towing with dump bed.
- Remove rear end panel before dumping.
- If maintenance needs to be performed to the trailer below the dump bed, first block wheels and remove dump bed.
- Do not allow anyone to ride in the dump bed or on the trailer.
- Keep children and pets at least 30 feet away from the trailer and under the observation of a responsible adult.
- Look around and behind the trailer before backing up and back up slowly with caution.
- Only tow trailer in off-road areas. Not intended for use on public roads.
- Vehicle Braking, handling and stability may be affected with the addition of this trailer. Be aware of changing conditions and slopes at all times.
- An improperly coupled trailer can result in death or serious injury. Tighten the coupler adjustment regularly.

293961

**#293961**

### **LOAD RATING**

293981

**Max Dumping Capacity 650 pounds**  
**Max Lifting Capacity 440 pounds**

**#293981**

### **WARNING**

- Read and understand owner's manual before using this trailer or the winch
- Max Towing Capacity 2000 pounds
- Never exceed the towing capacity of the tow vehicle
- Check that the coupler is properly adjusted, secured and locked before each use
- Not intended for use on public roads

294011

**#294011**

## Protecting Yourself and Those Around You

---

### **WARNING**

You must operate the Trailer safely. Unsafe operation can create a number of hazards for you, as well as anyone else in the nearby area. Always take the following precautions when using this trailer:

- Never exceed the rated towing capacity of the Tow Vehicle. Keep in mind that the operator or user is responsible for accidents or hazards occurring to other people, their property, and themselves.
  - We recommend wearing gloves and protective goggles or safety glasses with side shields while assembling or using the DR VERSA TRAILER and the supplied Winch.
  - Wear shoes with non-slip treads when assembling or operating your Trailer. If you have safety shoes, we recommend wearing them. Do not assemble or use the Trailer while barefoot or wearing open footwear.
  - Wear long pants while assembling or operating the DR VERSA TRAILER and a long sleeved shirt to protect from accidental scrapes, cuts, or abrasions that may result.
  - Do not transport people on or inside the Trailer. The transport of people puts their lives at risk and may be illegal, as the Trailer has not been designed to carry passengers.
  - Do not transport flammable, explosive, poisonous, or other dangerous materials in your Trailer.
- 

## Safety for Children and Pets

---

### **WARNING**

Tragic accidents can occur if the operator is not alert to the presence of children and pets. Children are often attracted to the Trailer and the hauling activity. *Never* assume that children will remain where you last saw them. Always follow these precautions:

- Keep children and pets at least 30 feet away from the working area and ensure they are under the watchful care of a responsible adult.
  - Be alert and stop what you are doing if children or pets enter the work area.
  - Never allow children to operate the tow vehicle or the DR VERSA TRAILER.
  - Use care when backing up to make sure the area is clear of children, pets, and other objects that could result in damage or injury.
- 

## General Safety

---

### **WARNING**

Operating this DR VERSA TRAILER safely is necessary to prevent or minimize the risk of death or serious injury. Unsafe operation can create a number of hazards for you. Always take the following precautions when operating this Trailer:

- Your DR VERSA TRAILER is not a plaything. Exercise extreme caution at all times. The Trailer is designed for hauling material. Do not use it for any other purpose.
  - Know how to operate and stop the Tow Vehicle quickly; refer to the Tow Vehicle's Owner's Manual.
  - Never, under any conditions, remove, bend, cut, fit, weld, or otherwise alter standard parts on the DR VERSA TRAILER. Modifications to your Trailer could cause personal injuries and property damage and will void your warranty.
  - Before performing any maintenance or inspection procedure on the DR VERSA TRAILER, park first on flat, level ground. Place Vehicles with Automatic Transmission in Park. For Vehicles with Manual Transmission, place Vehicle in the configuration recommended by the Vehicle's Owner's Manual. Set the Tow Vehicle's Parking Brake (if equipped), shut the Engine OFF, and remove the Key. Chock the wheels of the Tow Vehicle to ensure that the Vehicle cannot move. Ensure that the Bed of the Trailer is completely lowered and is resting on the Frame of the Trailer.
  - Never allow people who do not understand and/or have not read this Safety and Operating Instructions Manual to use the DR VERSA TRAILER. Allow only responsible individuals who are familiar with these rules of safe operation and the safe operation of your Tow Vehicle to use your Trailer.
  - Never overload the Trailer. Personal injury or damage to the Trailer could result.
  - While using the DR VERSA TRAILER, don't hurry or take things for granted. When in doubt, stop the Tow Vehicle and take the time to look things over.
  - Never operate the Trailer when under the influence of alcohol, drugs, medication, or if mentally or physically impaired.
  - Stay alert for hidden hazards or traffic.
  - Keep all nuts and bolts tight and keep the Trailer in good operating condition as outlined in Chapter 4: Maintaining the DR VERSA TRAILER.
-

## ***Safely Towing your DR VERSA TRAILER***

BEFORE towing your DR VERSA TRAILER, read the following:

### **WARNING**

- Driving a vehicle with a Trailer in tow is vastly different from driving the same vehicle without a trailer in tow. When towing a Trailer, you need more room to turn and more distance to stop. You will need to spend time adjusting to the different feel and maneuverability of the Tow Vehicle with a loaded Trailer.
- Never exceed the maximum tow rating for the Vehicle being used.
- An improperly coupled Trailer may result in death or serious injury. Before coupling the DR VERSA TRAILER to your Tow Vehicle, be sure the size of the Ball is 2". Make sure that the Hitch Ball is not worn or cracked and is tight on the Tow Vehicle's Hitch. Also check the Coupler for cracks and deformations and make sure that the Coupler is securely fastened to the Trailer Tongue with the Safety Snap Pin installed. Lubricate the Hitch Ball and the inside of the Coupler with a thin layer of grease. Make sure the Tow Hitch is adjusted properly to the Ball Hitch.
- Assure that the Trailer Wheel Lug Nuts are tight before towing as outlined in Chapter 4: Maintaining the DR VERSA TRAILER.
- Improper Tire pressure can result in a blowout and loss of control, which can lead to death or serious injury. Be sure the Tires are properly inflated to the pressure indicated on the sidewall of the Tire(s) before towing the Trailer.
- Make sure the Trailer's Jack and Crane Supports are fully retracted and the Crane is securely locked before towing.
- Use caution when towing the Trailer over rough terrain and hillsides to prevent loss of control and rolling over. Never operate near, or on slopes of 20 degrees or greater.
- Slow down for bumps and release the Tow Vehicle's accelerator when crossing the bump to avoid unintended acceleration.
- Do not brake while in a curve unless absolutely necessary. Instead, slow down before you enter the curve and power through the curve. This way, the Towing Vehicle remains in charge.
- Do not apply the brakes to correct extreme Trailer swaying. Continuing to pull the Trailer, with slight acceleration will provide a stabilizing force.
- Be careful when towing the Trailer in icy, wet, or snowy conditions, which could impair the braking ability and the stability of the Tow Vehicle.
- Driving too fast for conditions can result in loss of control and may cause death or serious injury. Decrease your speed as ground, weather, and lighting conditions deteriorate.
- Never exceed 25 mph.
- Use lower gears when climbing and descending grades.
- Your Tow Vehicle's braking and stability may be affected when towing the DR VERSA TRAILER.
- Do not ride the brakes while descending grades, as they may get so hot that they stop working. This may lead to a runaway Tow Vehicle and Trailer.
- Using the Trailer with a heavy load may exceed and inhibit the towing capacity of the Tow Vehicle. Do not exceed the maximum towing capacity of your Tow Vehicle. Check the Tow Vehicle's Owner's Manual on tow capacity limitations.
- Make sure the DR VERSA TRAILER is not overloaded and that the load is properly distributed front to back and side to side and properly secured. The Trailer's maximum towing capacity is 2000 pounds.
- Before operating the Tow Vehicle and DR VERSA TRAILER on any sloped surface or hill, refer to the Safety Rules in the Tow Vehicle's Owner's Manual on proper operation on slopes. Do not use on or near slopes over 20 degrees.
- Do not tow the Trailer on highways or on public thoroughfares. **The DR VERSA TRAILER is designed for off road use only.**

### ***A Note to All Users***

No list of warnings and cautions can be all-inclusive. If situations occur that are not covered by this manual, the operator must apply common sense and operate this DR VERSA TRAILER in a safe manner. Contact us at [www.DRpower.com](http://www.DRpower.com) or call Toll Free: 1-800-DR-OWNER (376-9637) for assistance.

## Chapter 2: Assembling The DR VERSA TRAILER

It may be helpful to familiarize yourself with the features of your DR VERSA TRAILER as shown in **Figure 1** before beginning these procedures. If you have any questions at all, please feel free to contact us at [www.DRpower.com](http://www.DRpower.com).

### DR VERSA TRAILER Features

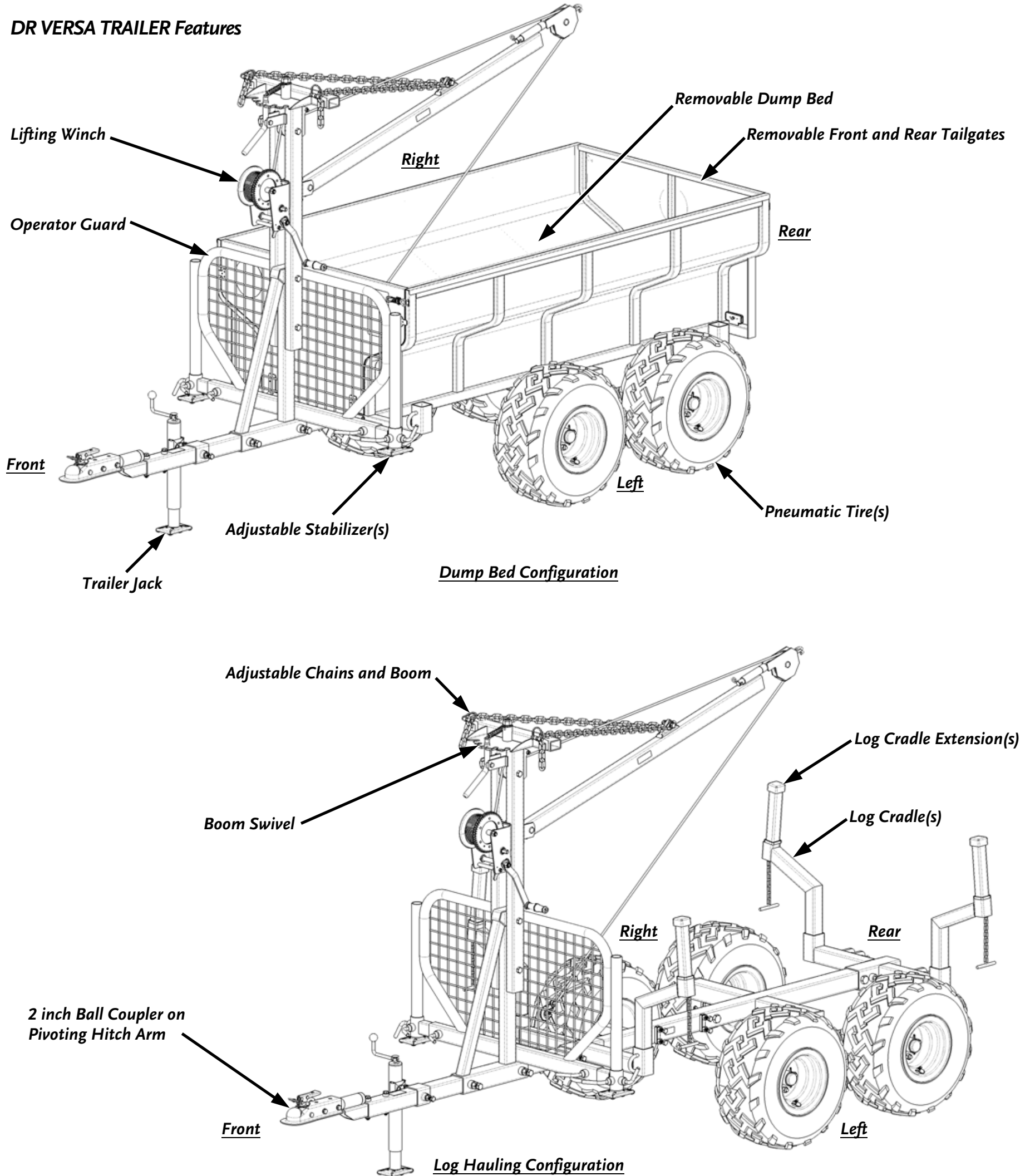

Figure 1

## Specifications

Tire Size	22 x 11-10
Trailer Dimensions	133" L x 51" W x 72" H
Operating Weight	680 pounds
Shipping Weight	760 pounds
Shipping Dimensions	82 1/2" L x 44 1/2" W x 26 1/2" H

## Unpacking the DR VERSA TRAILER

### WARNING

Due to the weight of the components of the DR VERSA TRAILER, we strongly recommend that you have the help of at least one other person in unpacking and assembling your new Trailer.

#### Tools and supplies needed:

- Utility Knife
  - Protective Goggles or Safety Glasses
  - Gloves
1. Cut the Banding from the Packaging and remove the Shipping Cover from the Shipping Crate and set it aside (**Figure 2**).
  2. Remove all of the Parts supplied from inside the Dump Bed.
  3. Using a Utility Knife carefully cut the wrap from the parts.
  4. Compare the contents (**Figures 3 & 4** on pages 8 & 9) with the parts supplied list. If you have any questions, **contact 1-800-DR-OWNER (376-9637)**. Do not discard your packaging material until you are fully satisfied with your new DR VERSA TRAILER, as you will need it if you decide to return your Trailer.

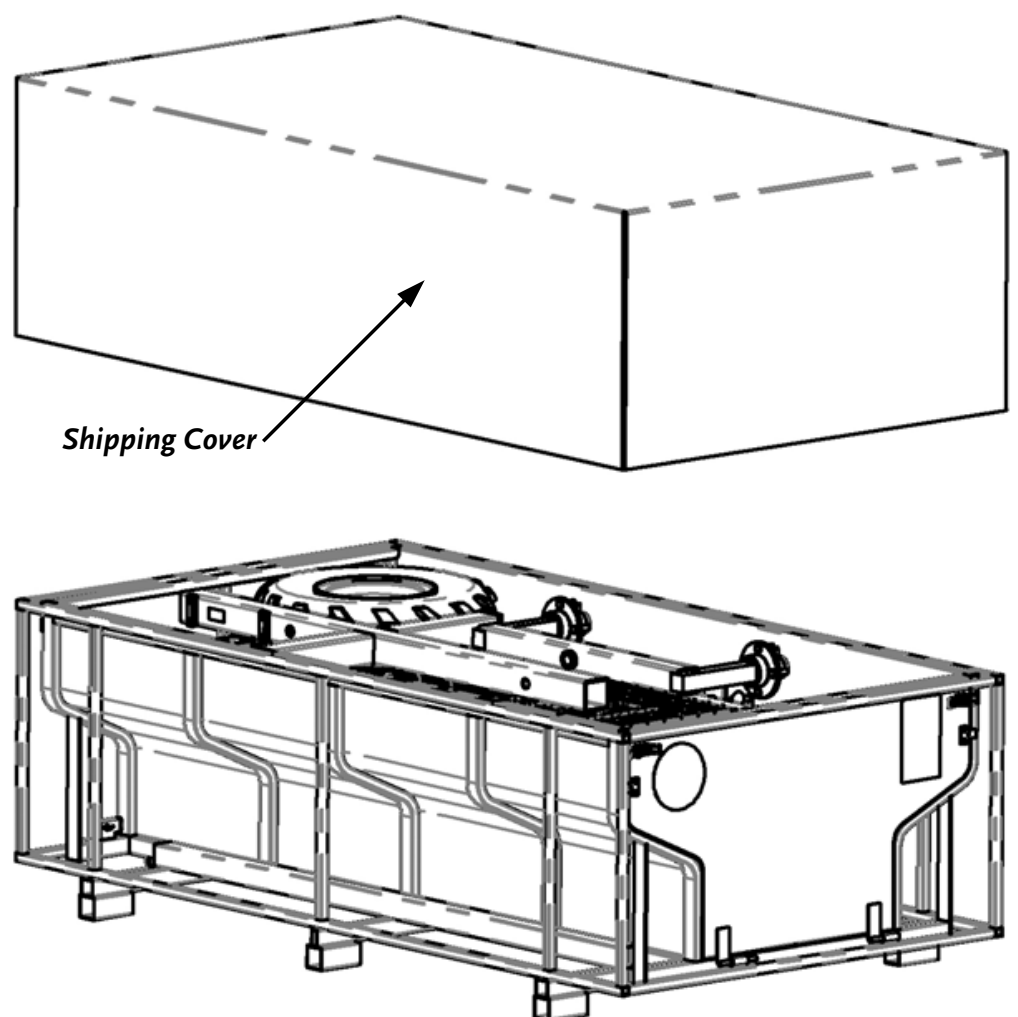

Figure 2

**The Parts shown here are included in the Hardware Kit Bag**

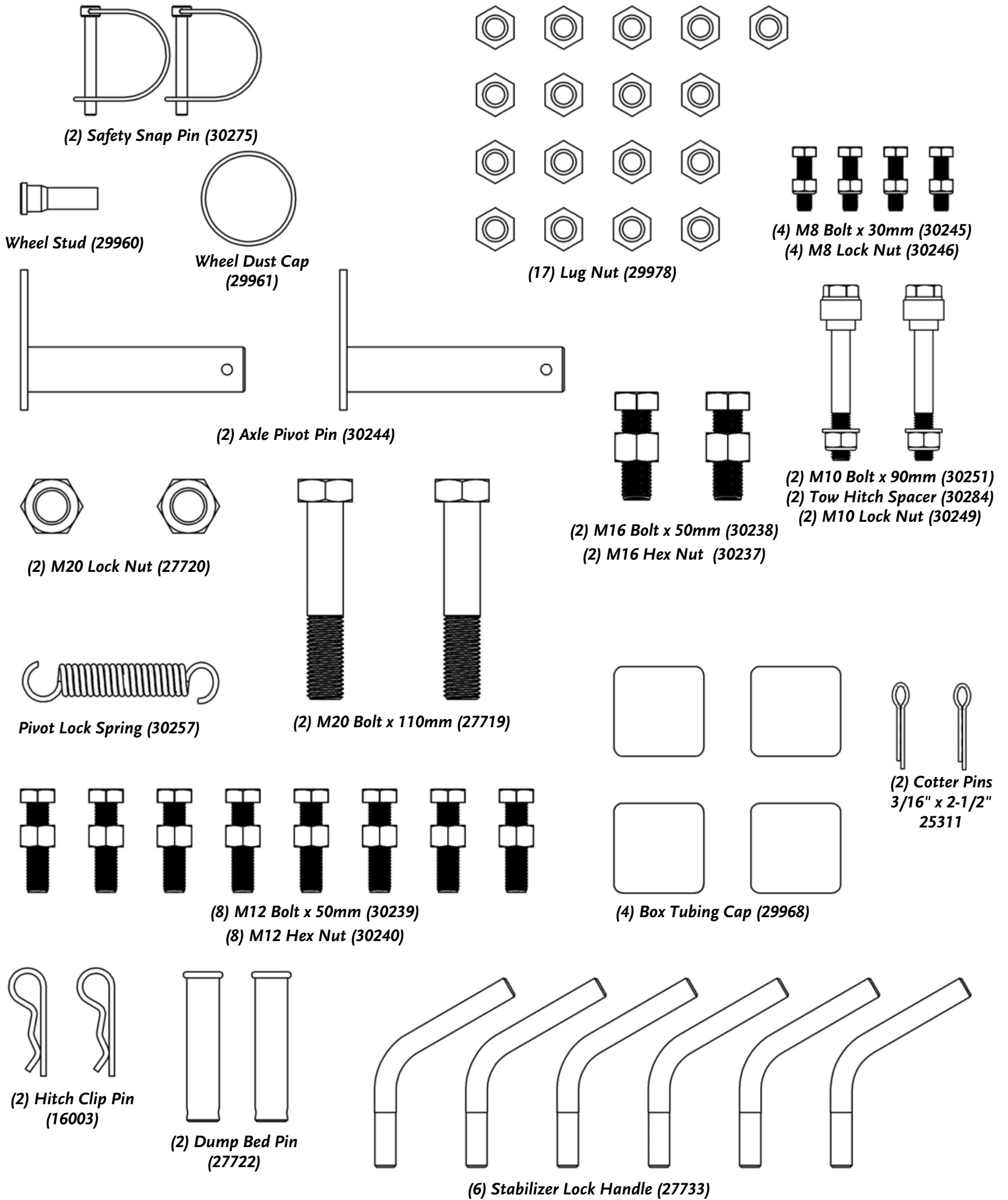
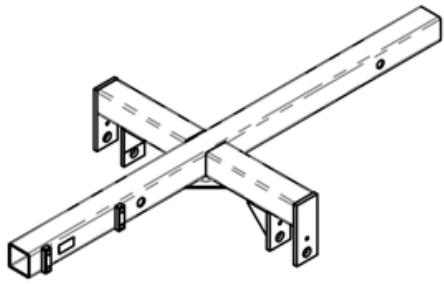
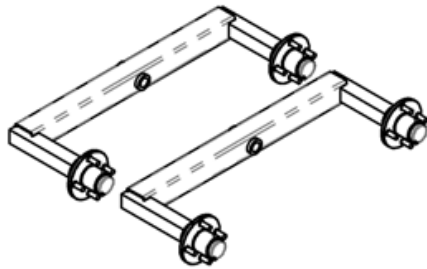

Figure 3





**Main Frame (29957)**



**(2) Axle and Hub Assembly (29958)**

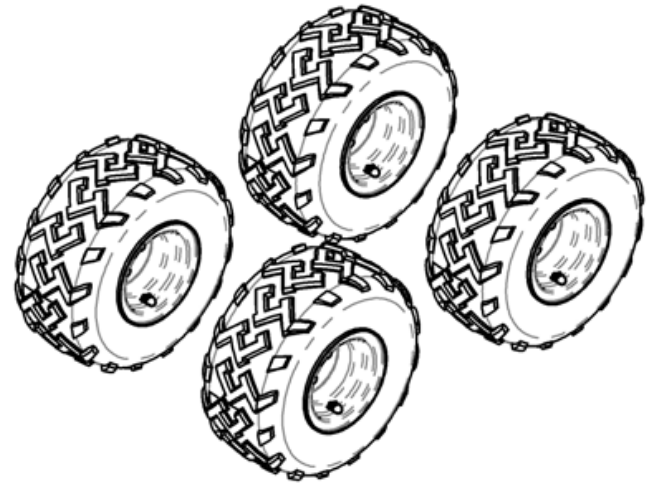

**(4) Wheel and Tire Assembly (29964)**

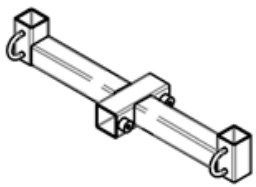

**Front Bed Support (29965)**

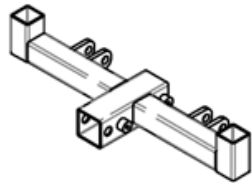

**Rear Bed Support (29969)**

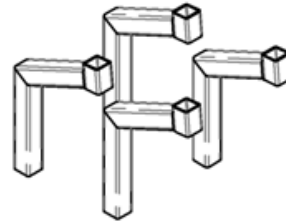

**(4) Log Cradle (29966)**

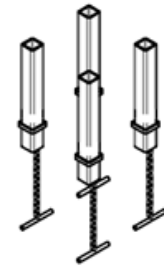

**(4) Log Cradle Extension (29967)**

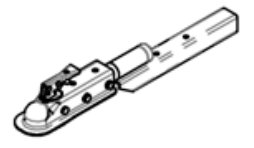

**Pivoting Tow Hitch (30270)**

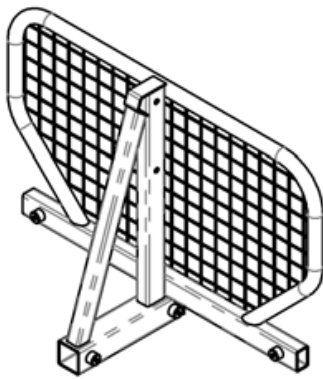

**Operator Guard (29971)**

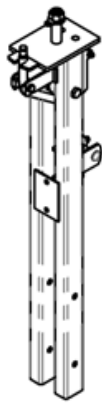

**Vertical Crane Support w/Pivot Handle (30268)**

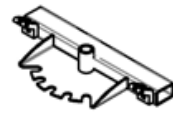

**Crane Pivot Lock (299731)**

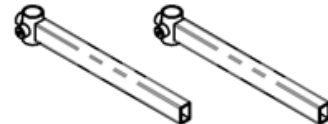

**(2) Stabilizer Bracket (277151)**

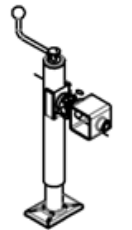

**Trailer Jack (277181)**

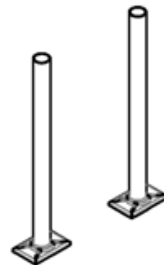

**(2) Stabilizer Leg (27716)**

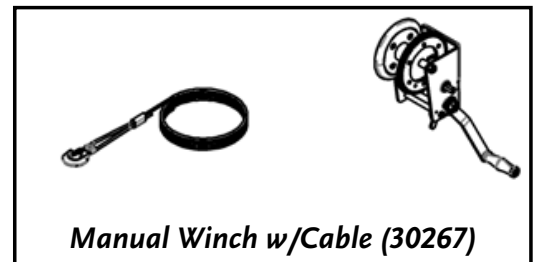

**Manual Winch w/Cable (30267)**

**Shipped Separately**

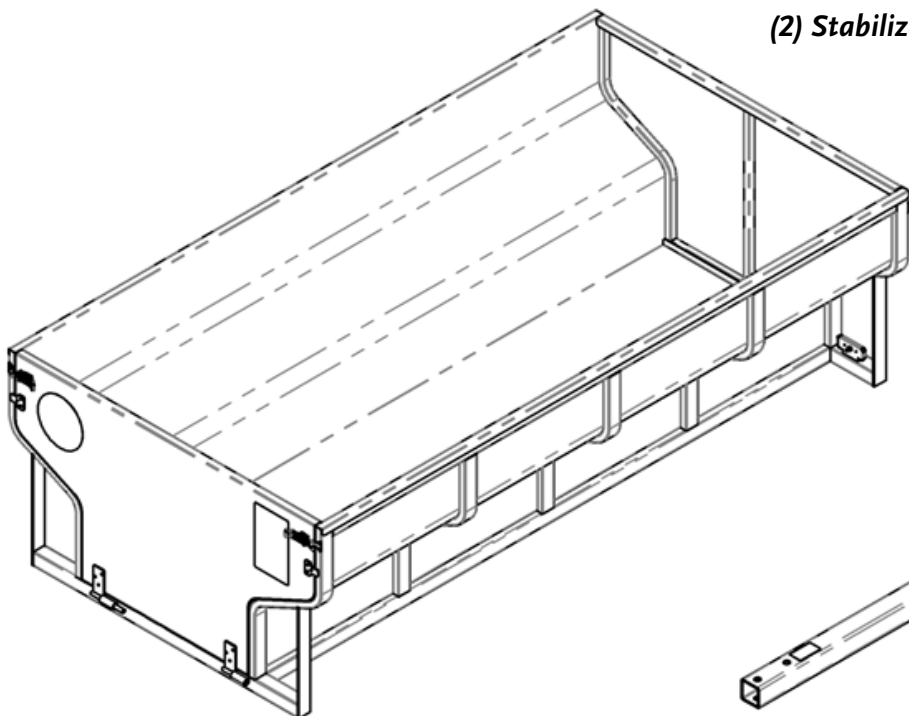

**Dump Bed w/Tailgates (30266)**

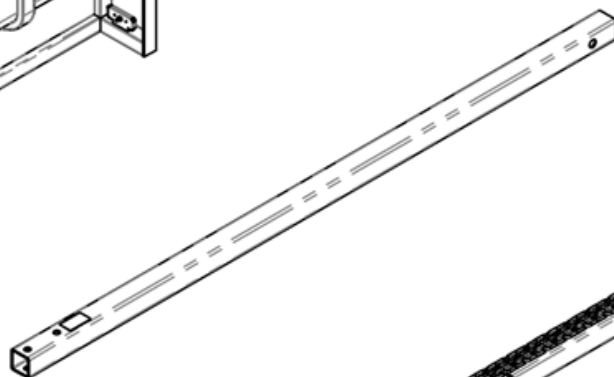

**Tow Bar w/Labels (30271)**

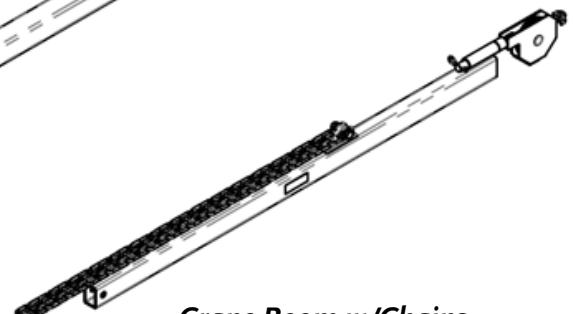

**Crane Boom w/Chains and Labels (30269)**

**Figure 4**

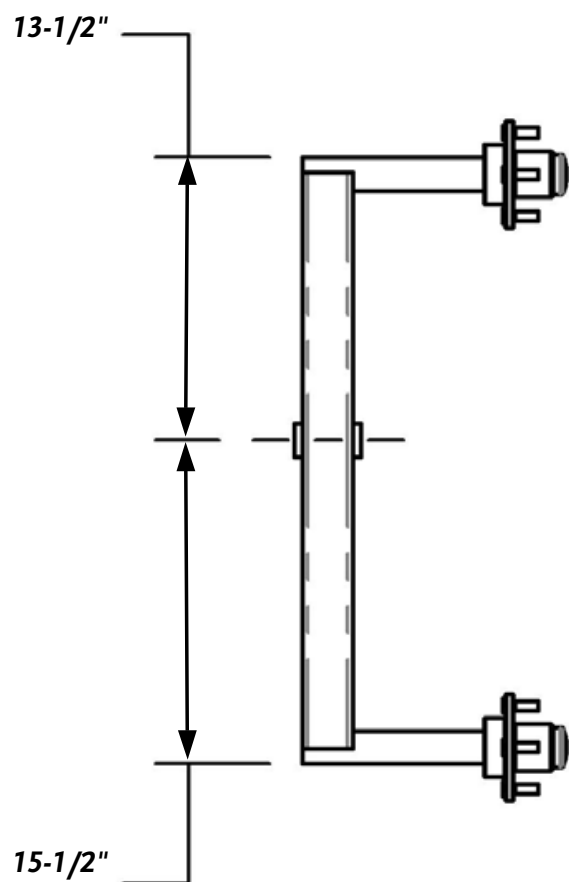

Figure 5

### Installing the Wheels and Tow Bar to the Main Frame

#### Tools Needed:

- Two Adjustable Wrenches capable of tightening a 30mm or 1-1/2" Bolt Head.
- 13mm Wrench required (12, 18, & 30mm Wrenches optional if two Adjustable Wrenches are available)
- Needle Nose Pliers
- 21mm Socket required (12, 18, & 30mm Sockets optional if Adjustable Wrenches available)
- Tape Measure
- 5" Socket Extension

1. Measure the Axles to determine the correct orientation for installation on the Trailer. The longer portion of the Axle (**Figure 5**) should face the Front of the Trailer.

**NOTE:** The Front of the Trailer has the two rectangular Bosses welded to the side of the Trailer.

2. Turn the Main Frame upside down. Install the Axles to the Main Frame by inserting the Axle Pivot Pins, with the Tab facing downwards, from the outside of the Main Frame through the Axles. Align the Hole through the Tab on the Pin with the Hole in the Main Frame and repeat for opposite side (**Figure 6**).

### ⚠ CAUTION

Take care not to Pinch hands or Fingers when installing the Axles and Axle Pivot Pins.

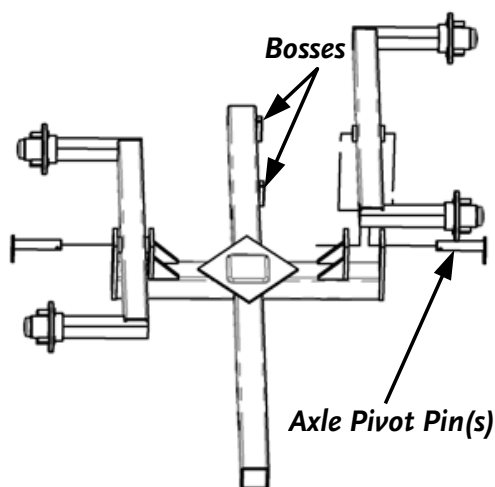

Figure 6

**NOTE:** It is easier to install the Axle Pivot Pins by first placing the Axle(s) between the mounting plates, then picking up one end of the Axle, while allowing the other to rest on the ground. This will take some of the weight off and allow you to align the holes much easier so you may insert the Axle Pivot Pin(s).

3. Insert a M8 x 30mm Mounting Bolt (**Figure 7**) from the inside of the Frame and through the Tab on the Axle Pivot Pin. Install a M8 Flange Nut and tighten with a 12mm Socket, holding the Bolt with a 13mm Wrench.
4. Insert a Cotter Pin (**Figure 7**) through the Left and Right Axle Pivot Pins and bend the legs over with Pliers.
5. Install the Left and Right wheels on the Axles with the supplied Lug Nuts until snug with a 21mm Socket and 5" Extension; they will be torqued later.

**NOTE:** The Wheels are marked L (Left) and R (Right), as they are directional Tires. Since the Main Frame is upside down, the Left Wheels should be installed on the Right Side and the Right Wheels on the Left Side (**Figure 8**). Make sure the Valve Stem(s) face outwards. The Lug Nuts must be installed with the tapered side of the Nuts facing the Hub of the Wheel (**Figure 9**).

6. Turn the unit over with the assistance of at least one other person.

**NOTE:** The easiest way of turning the unit over is to lift the two Wheels on the Right Side of the Trailer while pivoting over the Wheels on the Left Side (**Figure 10**).

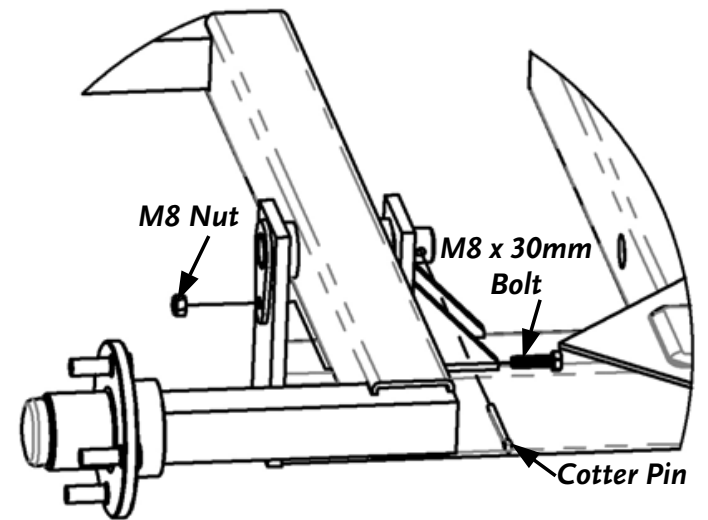

Figure 7

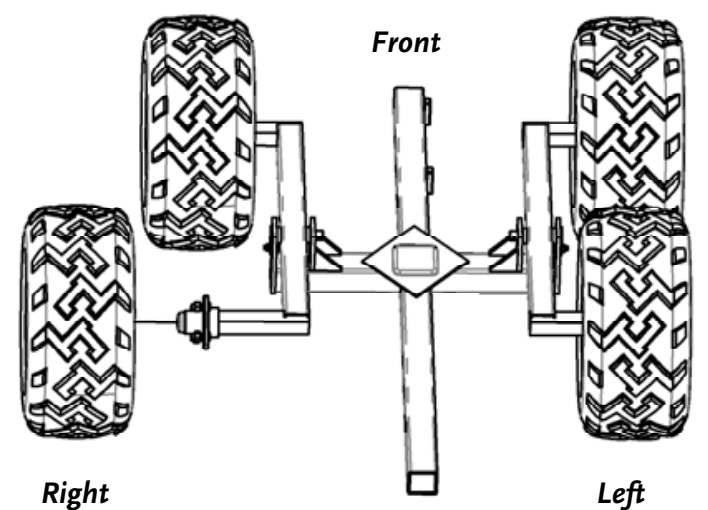

Figure 8

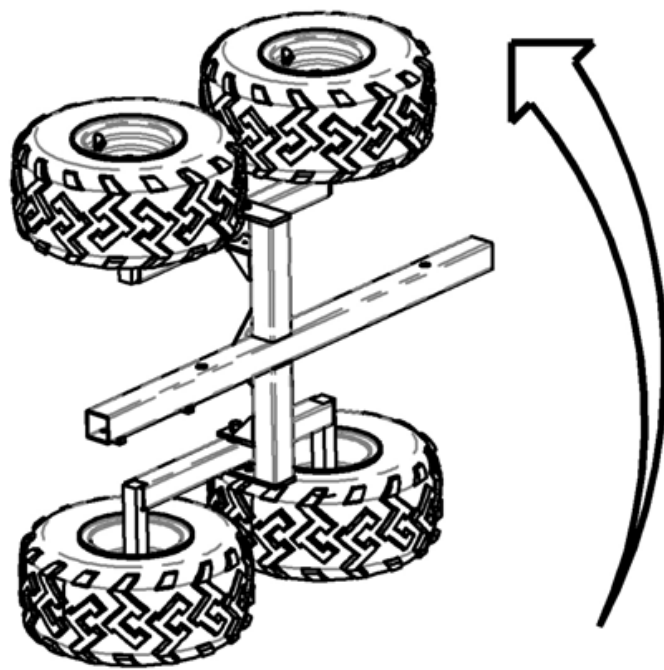

Figure 10

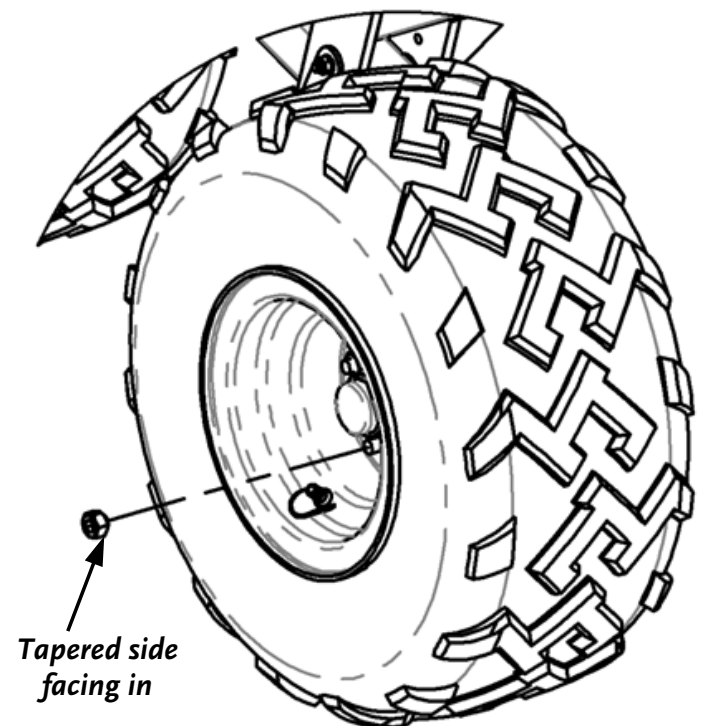

Figure 9

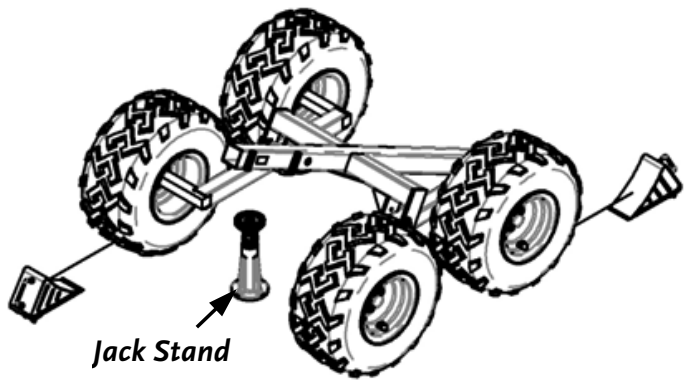

Figure 11

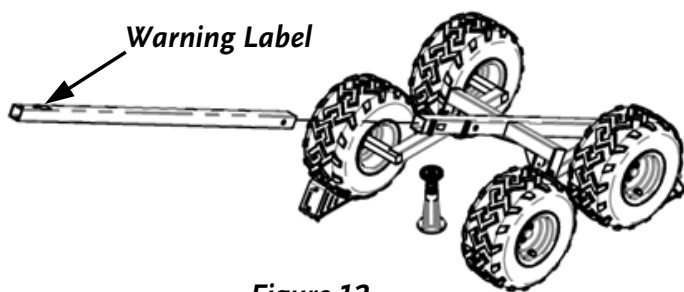

Figure 12

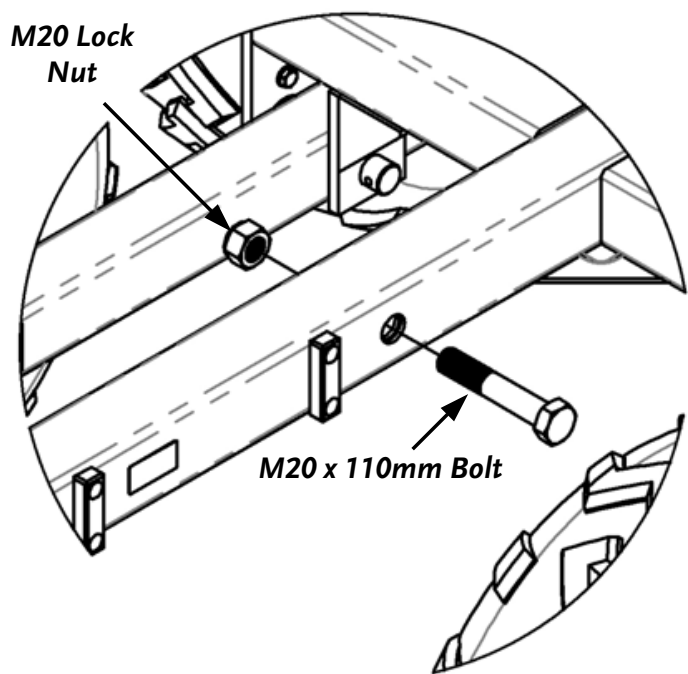

Figure 13

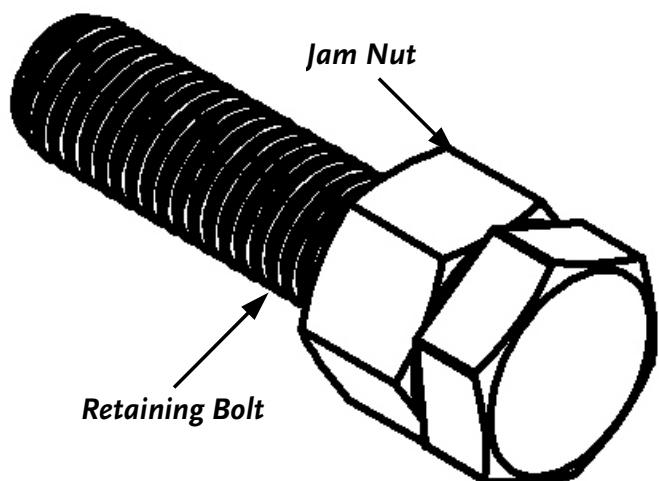

Figure 14

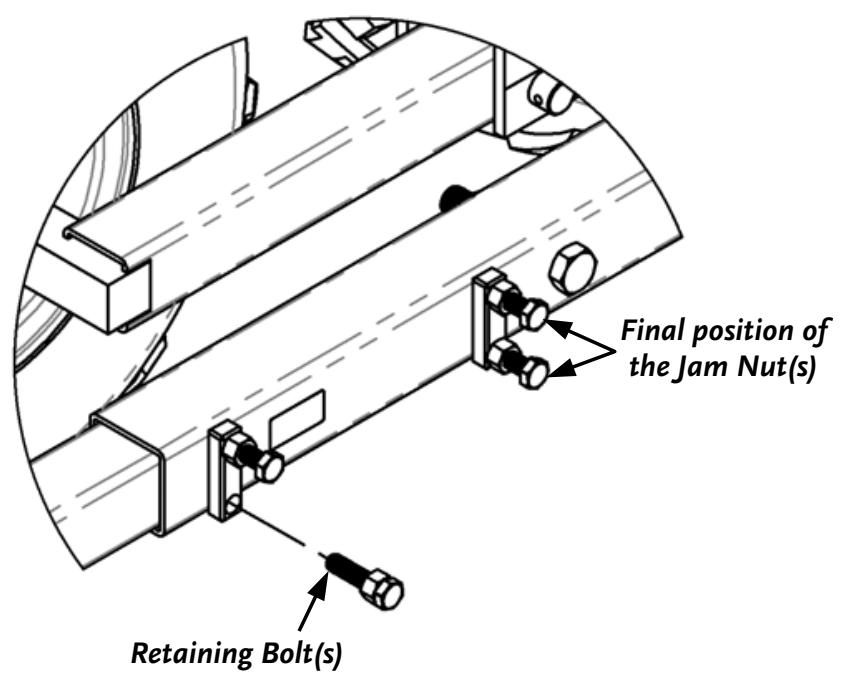

Figure 15

7. Place a Jack Stand under the front of the Main Frame, which should naturally be tipped backwards (**Figure 11**). Also place one wheel chock in front of one of the Front Wheels and one wheel chock behind one of the Rear Wheels to ensure the Trailer will not roll on you during assembly.
  8. Slide the Tow Bar (with the Warning Label on top) into the Main Frame, lining up the Mounting Hole with the hole in the Main Frame (**Figure 12**). Gently allow the weight of the Tow Bar to force the front of the Main Frame down onto the Jack Stand.
  9. Install a M20 x 110mm Bolt and Washer (**Figure 13**) in the Mounting Hole, and install a M20 Lock Nut. Tighten with Adjustable Wrenches or a 30mm Socket and an Adjustable Wrench.
  10. Back the Jam Nuts on the four Retaining Bolts (**Figure 14**) all the way to the head of the Bolts.
- Note:** You will need to back all Jam Nuts off, to the head of the Retaining Bolts for all hardware shipped in the Hardware kit prior to installation (**Figure 14**). Be sure to tighten the Bolt first and then secure it by tightening the Jam Nut.
11. Insert the four Retaining Bolts into the Bosses on the left side of the Main Frame and securely tighten with an 18mm Socket (**Figure 15**).
  12. Screw in the Jam Nuts against the Boss and tighten with an 18mm Wrench.

## Attaching the Front Bed Support, Operator Guard, Trailer Jack & Pivoting Tow Hitch w/Coupler

### Tools Needed:

- 17mm, 18mm, and 24mm Wrenches or an Adjustable Wrench
  - 16mm Socket
  - Tape Measure
1. Slide the Front Bed Support onto the Tow Bar with the Mounting Bosses facing the Left, 9-1/2" from the end of the Main Frame (**Figure 16**).
  2. Install and tighten two M12 x 50mm Bolts and Jam Nuts with an 18mm Socket for the Bolts and an 18mm Wrench for the Nuts (**Figure 17**).
  3. Slide the Operator Guard onto the Tow Bar with the Mounting Bosses facing to the Left, 26" from the end of the Main Frame (**Figure 16**).
  4. Install two M16 x 50mm Bolts with M16 Jam Nuts (**Figure 18**) into the Operator Guard Bosses on the Right Side and tighten the Bolts with a 24mm Socket and the Jam Nuts with a 24mm Wrench or Adjustable Wrench.
  5. Slide the Trailer Jack 10-1/2" onto the Tow Bar (**Figure 16**), with the Mounting Boss facing the Left side of the Trailer. Tighten the M16 x 50mm Trailer Jack Bolt and M16 Jam Nut with a 24mm Socket and Wrench.

**NOTE:** You may need to loosen the Bolt installed in the Trailer Jack prior to installation to be able to slide the Jack onto the Tow Bar.

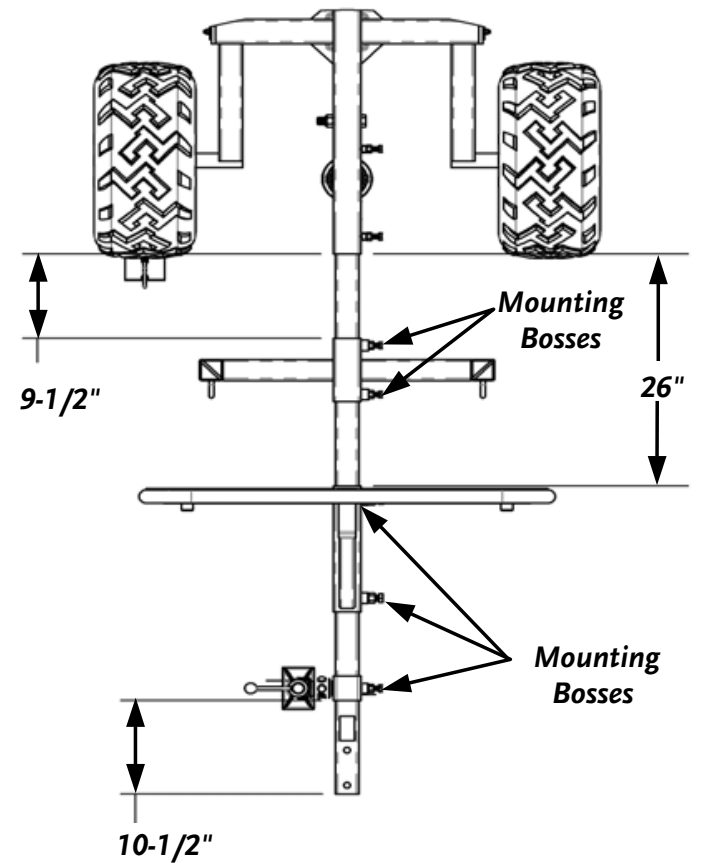

Figure 16

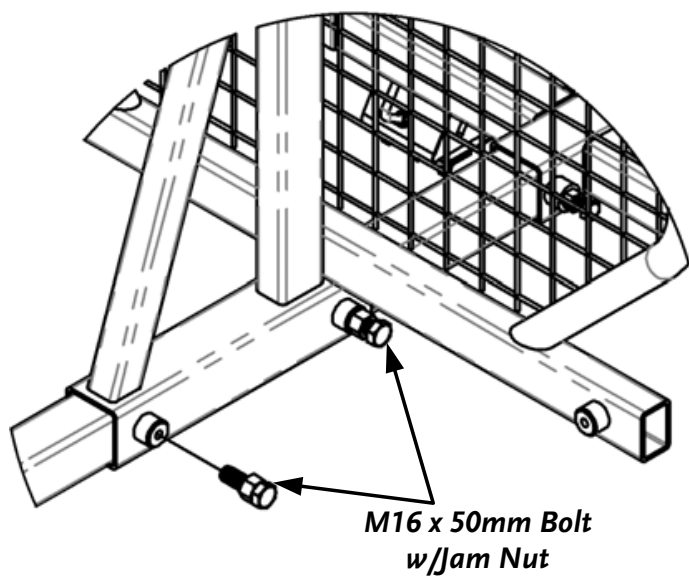

Figure 18

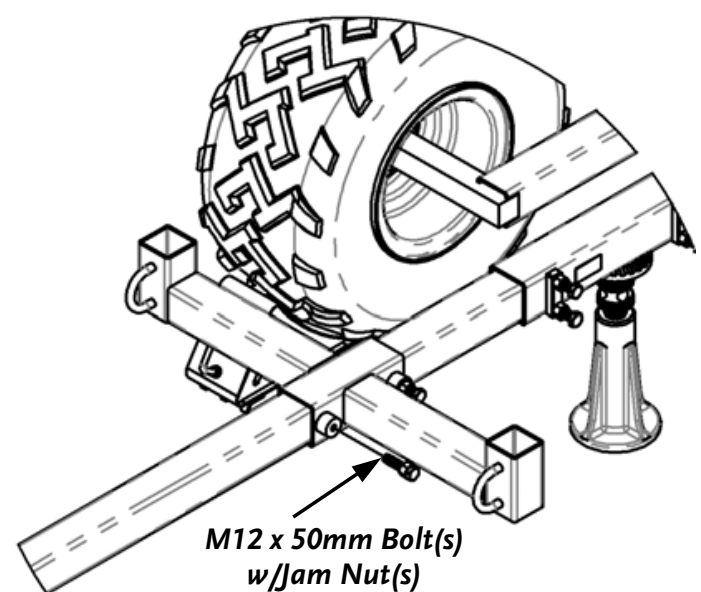

Figure 17

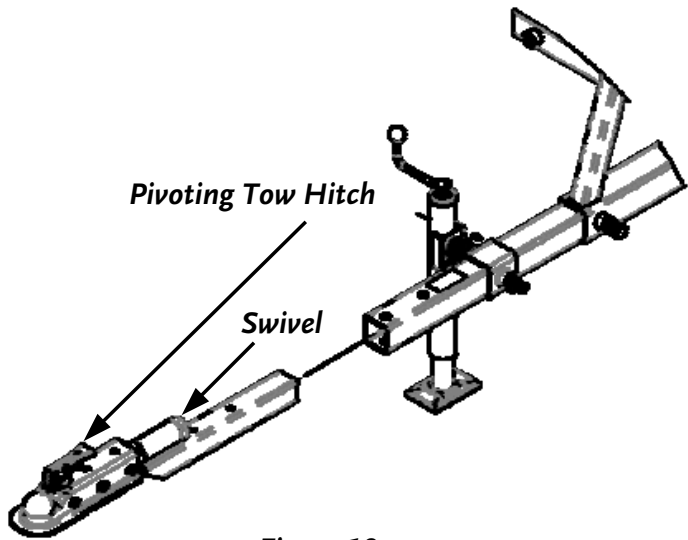

Figure 19

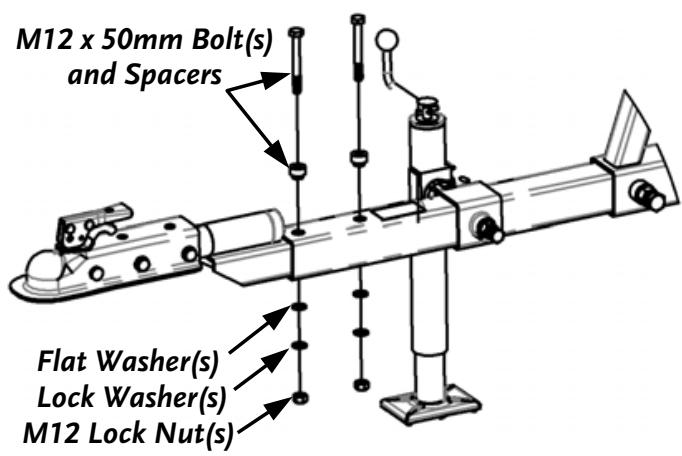

Figure 20

6. Install the Pivoting Tow Hitch (**Figure 19**) into the Tow Beam with the Swivel facing upward.
7. Install two M12 x 50mm Bolts and Spacers, with the smaller diameter Shoulder(s) down, (**Figure 20**) through the Tow Bar and Pivoting Tow Hitch. Install a Flat Washer, Lock Washer, and M12 Lock Nut on each Bolt and tighten with a 16mm Socket while holding the Nut with a 17mm Wrench.

#### Attaching the Adjustable Stabilizer Legs and Arms

### ⚠ CAUTION

Watch your feet when lowering the Stabilizer Legs.

1. Slide the Stabilizer Legs (**Figure 21**) all the way into each Adjustable Stabilizer Arms and screw in and tighten the Locking Handles (**Figure 22**) to hold the Legs in place.
2. Slide the Adjustable Stabilizer Arms all the way into the Operator Guard and screw in two Locking Handles to hold the Arms in place (**Figure 23**).
3. Loosen the Locking Handles holding up the Stabilizer Legs until they drop to the ground and retighten them. Remove the Jack Stand from under the Trailer.

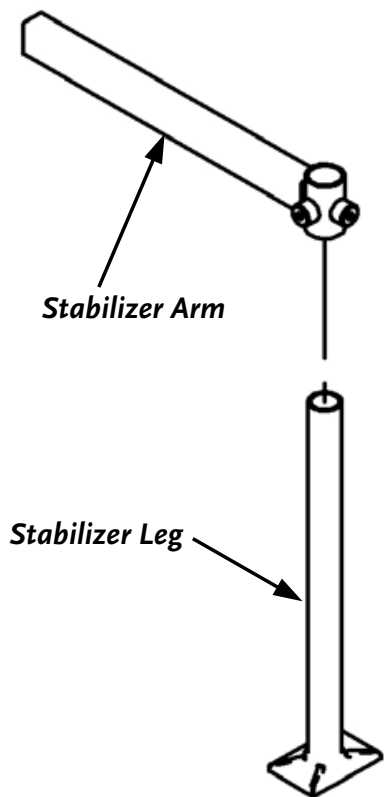

Figure 21

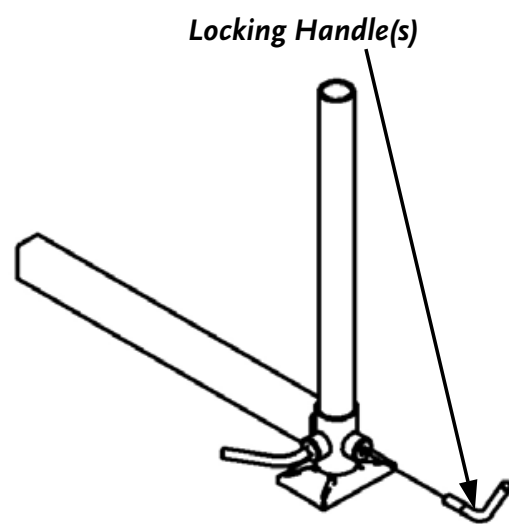

Figure 22

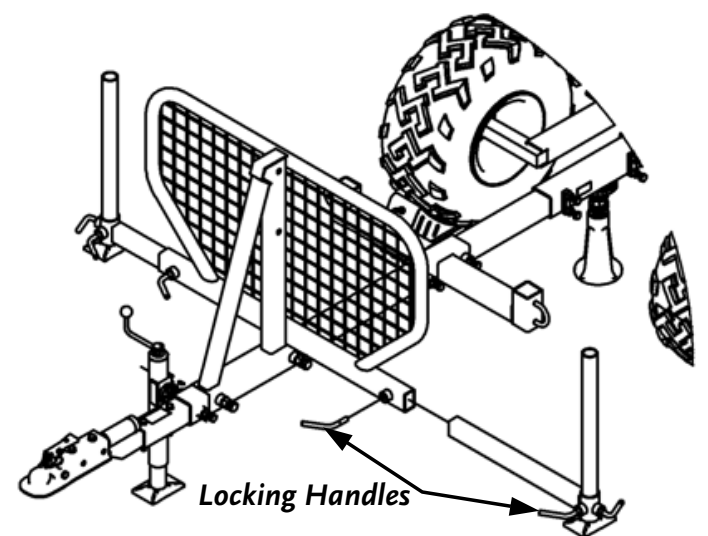

Figure 23

## Attaching the Crane

### Tools Needed:

- 22mm and 17mm Wrench
- 21mm, 16mm and 30mm Sockets
- Large Adjustable Wrench

1. Remove the Lock Nut, Flat Washer, and Tabbed Washer from the top of the Crane (**Figure 24**) along with the Pivot Lock Handle by removing the M10 x 1.75mm Bolt and M10 Lock Nut with a 16mm Socket for the Bolt and a 17mm Wrench for the Nut.

2. Remove the two M14 x 140mm Bolts and M14 Nuts from the Crane with a 21mm Socket for the Bolt and a 22mm Wrench for the Nut.

3. Install the Boom Pivot (**Figure 25**) on top of the Crane with the Mounting Boss pointing up and re-install the Tabbed Washer 1<sup>st</sup>, Flat Washer 2<sup>nd</sup>, then the Lock Nut. Do not tighten yet.

4. Lay the Crane on the Operator Guard, with the Diagonal Support of the Operator Guard between the two legs of the Crane (**Figure 26**). Snug the Lock Nut on the Boom Pivot using a large Adjustable Wrench, or a 30mm Socket making sure the Tabbed Washer is facing downward. Back the Nut off ½ turn, to make sure the Boom Pivot rotates freely.

5. With the assistance of another person, rotate and lift the Crane to the vertical position (**Figure 27**). Install two M14 x 140mm Bolts, from the Left side, through the Crane and Operator Guard and attach the M14 Lock Nuts. Tighten using a 21mm Socket on the Bolt and a 22mm Wrench on the Nut (**Figure 27**).

6. Install the Pivot Lock Handle in the orientation shown in **Figure 27** with the hardware removed in Step 1 of this section.

7. Install the Extension Spring on the Boom Pivot Handle. Hook one end around the Handle and the other end through the Tabbed Washer (**Figure 28**) on the Boom Pivot. Ensure that the Spring is properly seated in the Groove on the Boom Pivot Handle.

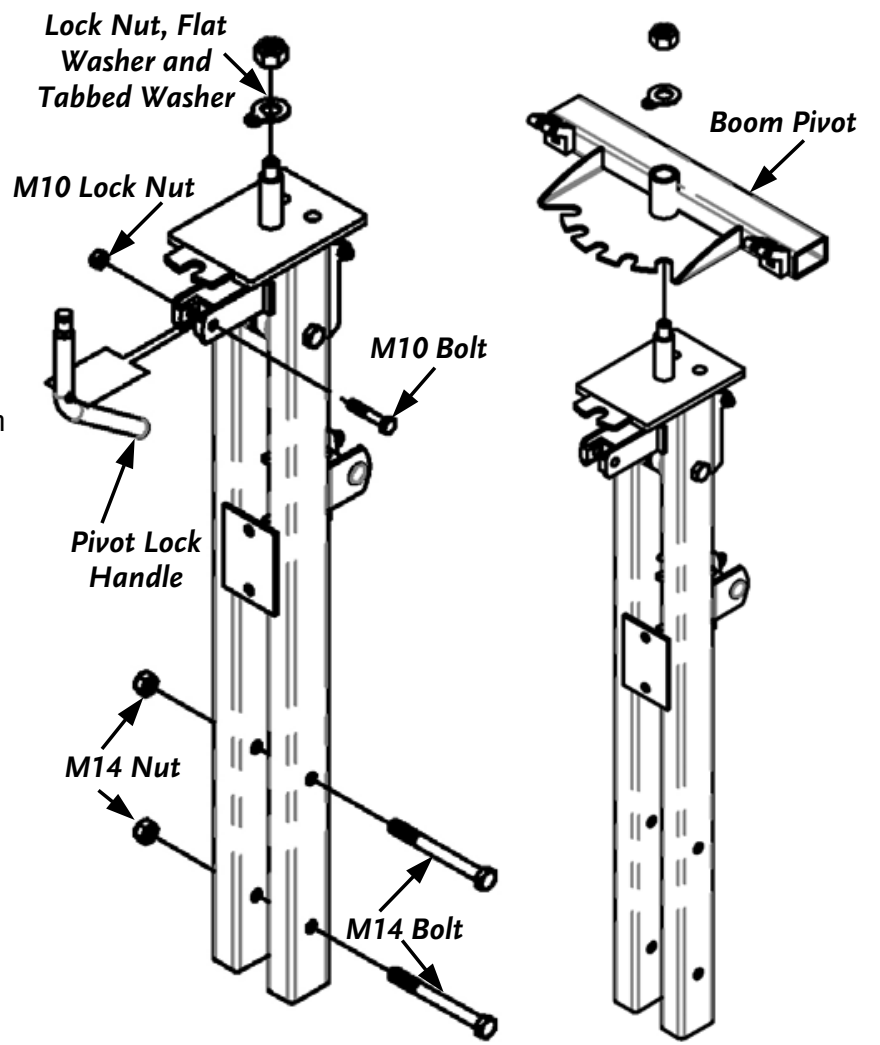

Figure 24

Figure 25

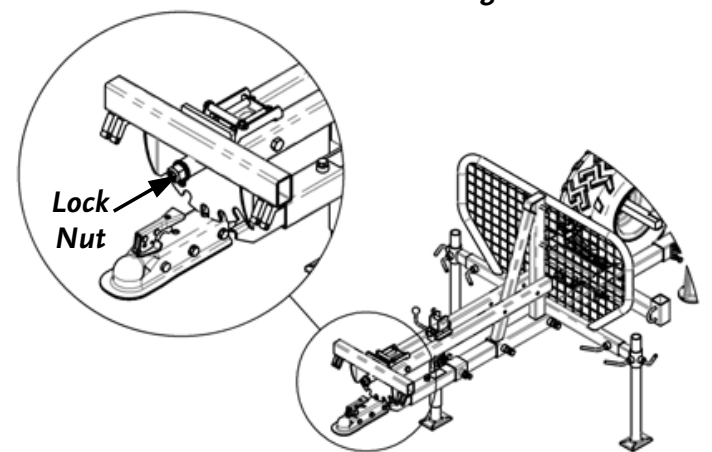

Figure 26

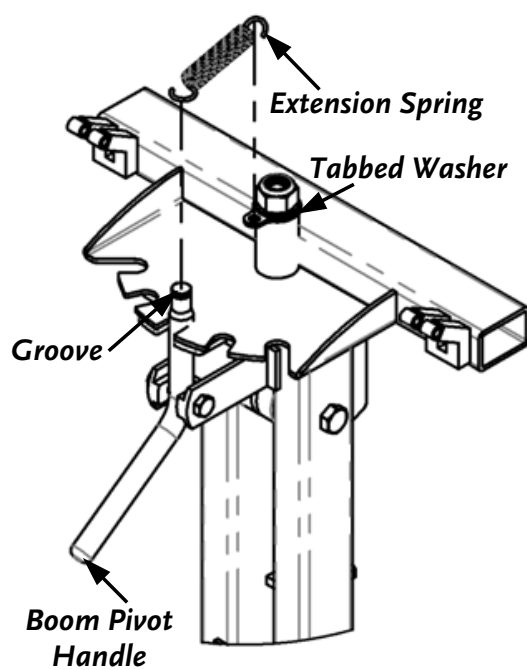

Figure 28

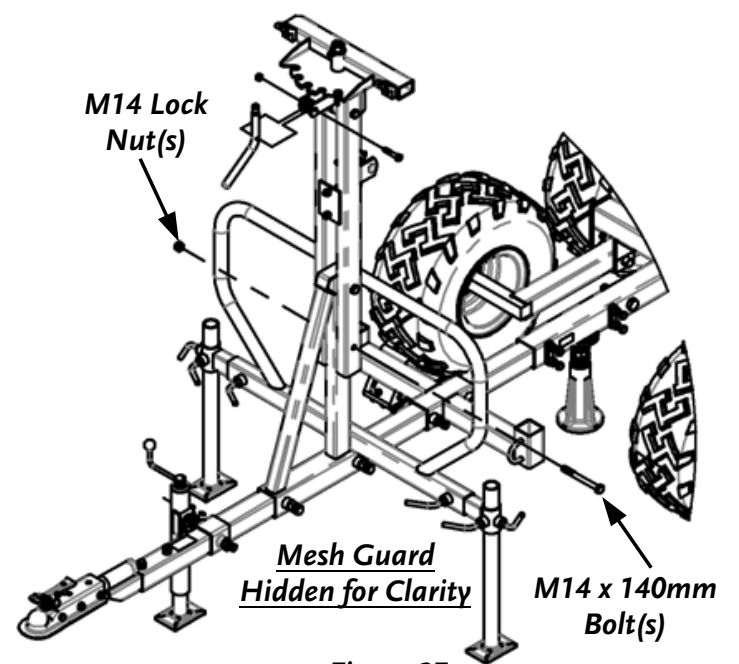

Figure 27

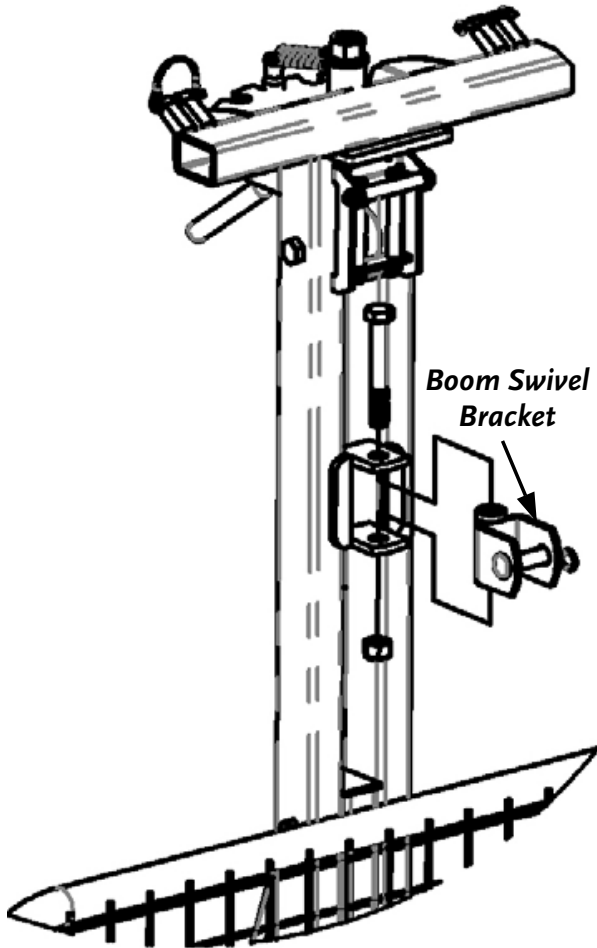

Figure 29

### Attaching the Winch and Boom

#### Tools Needed:

- 17mm and 22mm Wrench
- 17mm, 21mm, and 24mm Socket
- 5" Long Socket Extension
- Adjustable Wrench

**NOTE:** Before installing the Winch and Boom to your DR VERSA TRAILER, follow the instructions shipped with your Winch to properly install the Handle and Cable. You may want to install the Cable after the Winch has been installed to your Trailer.

1. Remove the Boom Swivel Bracket (**Figure 29**) using a 24mm Socket and Adjustable Wrench.
2. With the assistance of a second person, install the Winch (**Figure 30**), with the Crank Handle facing to the Left, using two M10 x 25mm Bolts, and Lock Nuts. Tighten using a 17mm Socket w/Extension and Adjustable Wrench and reinstall the Boom Swivel Bracket.
3. Remove the Cable Guide (**Figure 31**) using a 21mm Socket on the Bolt and a 22mm Wrench on the Nut.
4. Pull the Winch Hook up through the Cable Guides on the Crane (**Figure 32**) and reinstall the Cable Guide with the Cable on Top of the Guide (**Figure 33**). Make sure that Guide is free to rotate.

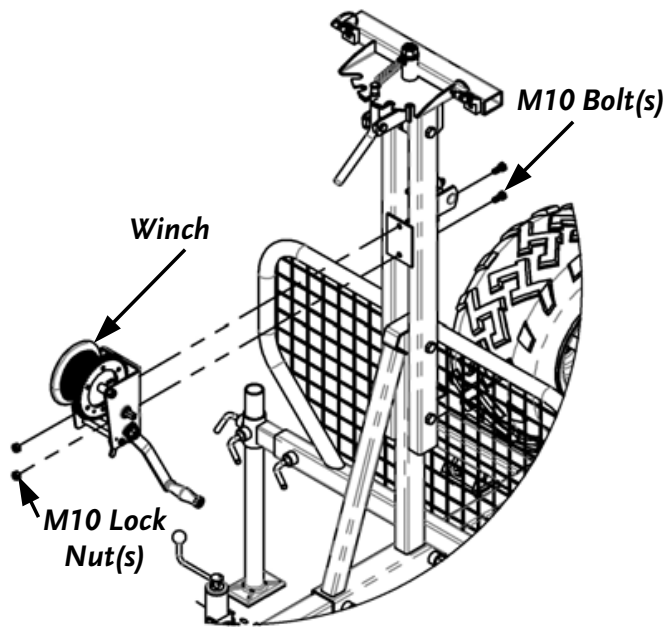

Figure 30

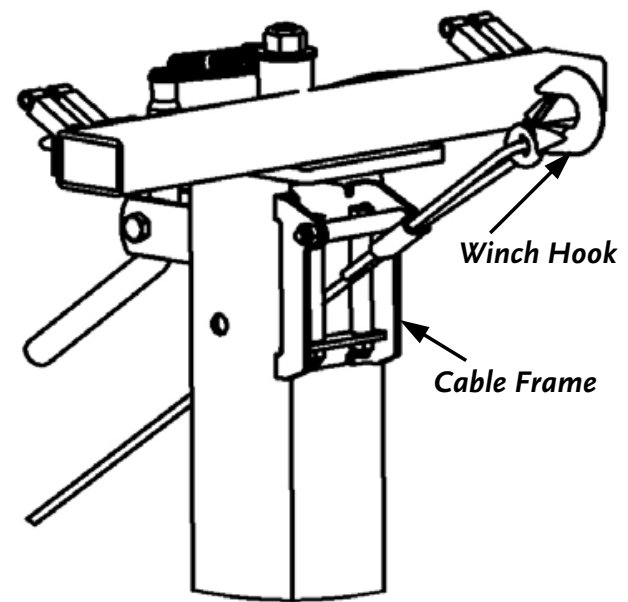

Figure 32

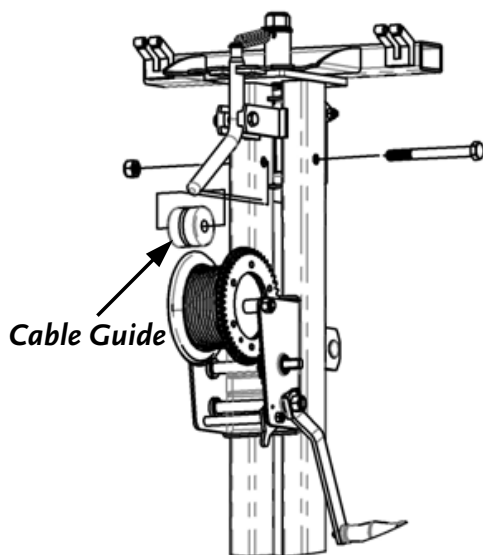

Figure 31

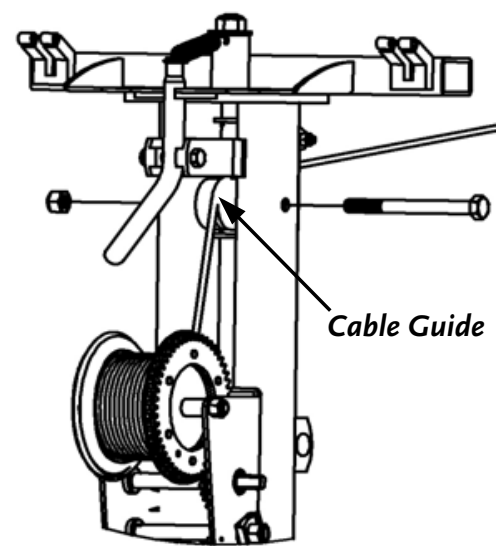

Figure 33



5. Reinstall the Boom Swivel Bracket and hardware, and then remove the Hitch Clip Pin and Pin from the Bracket (**Figure 34**).
6. Install the Boom to the Boom Swivel Bracket with the Chain Attachment Bracket on the Boom pointing up (Chains not shown for clarity), using the Hitch Clip Pin and Pin that was removed in step 5 (**Figure 35**).
7. Have a second person lift the Boom then hook the fourth link of the Left and Right Chains into the Boom Pivot (**Figure 36**) and insert a Hitch Clip in the Boom Pivot on both sides to secure the Chains (**Figure 36**).
8. With the assistance of another person, pull the Winch Cable forward, while the other person cranks the Winch in reverse to let the Cable out and loop it around the Rear Cable Support. Thread the Cable in horizontally between the two Hooks (**Figure 37**) to hold it in place.

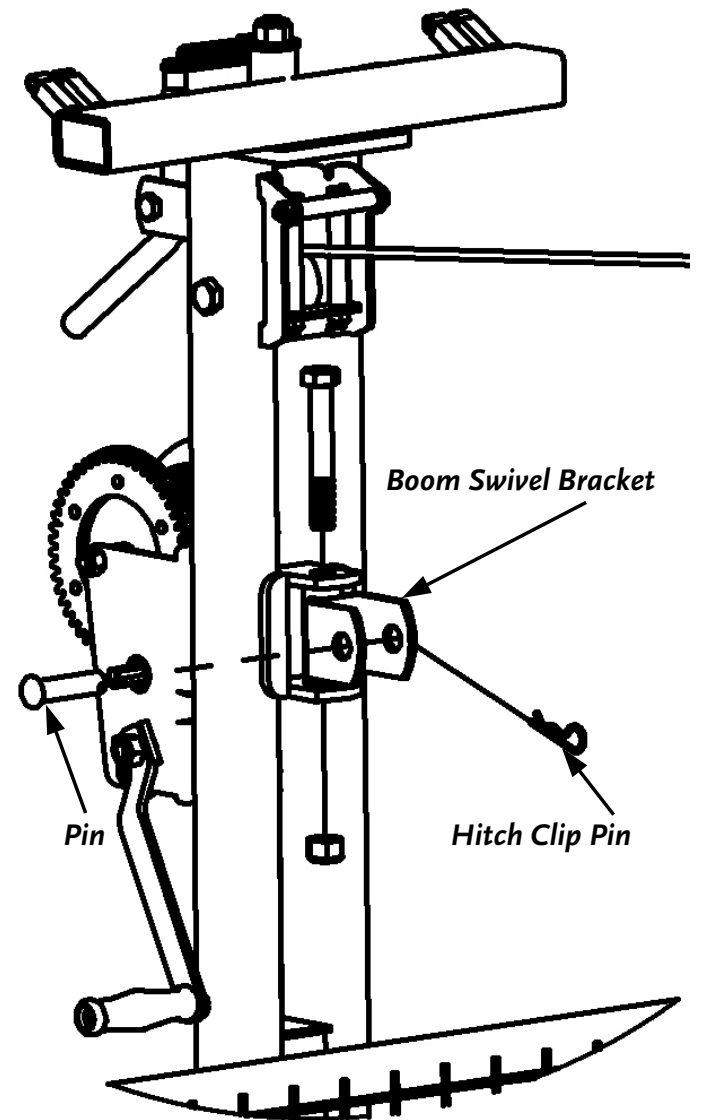

Figure 34

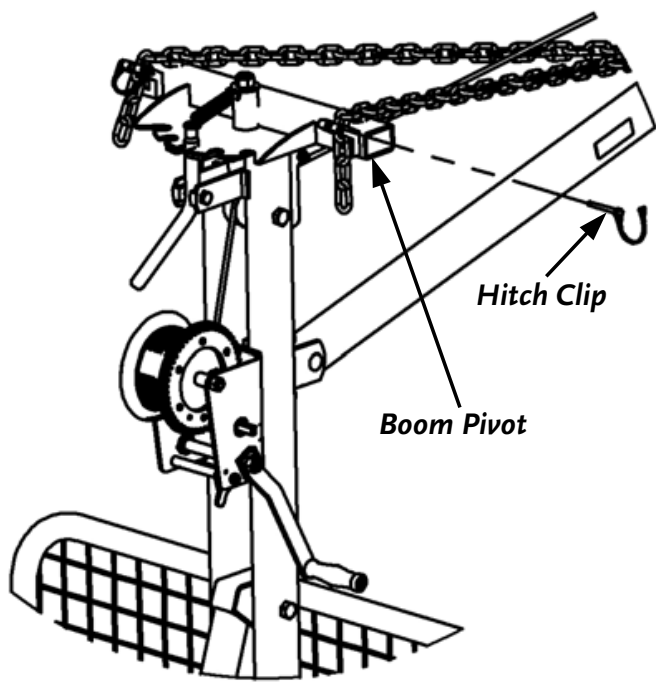

Figure 36

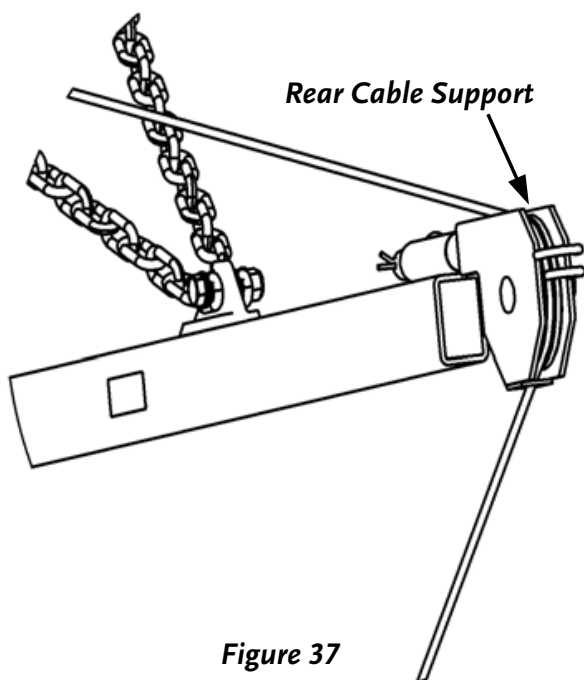

Figure 37

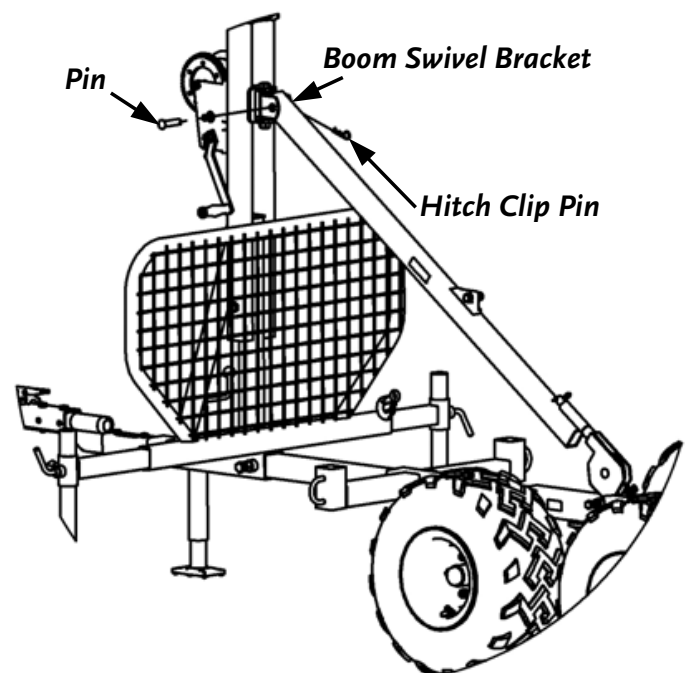

Figure 35

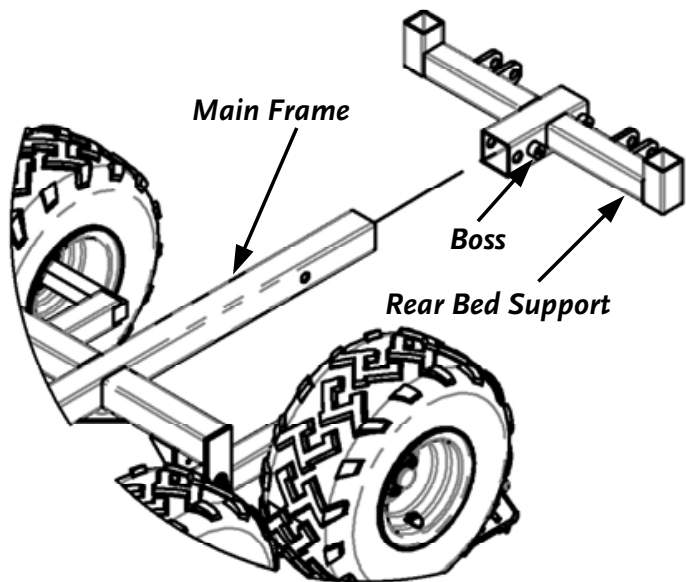

Figure 38

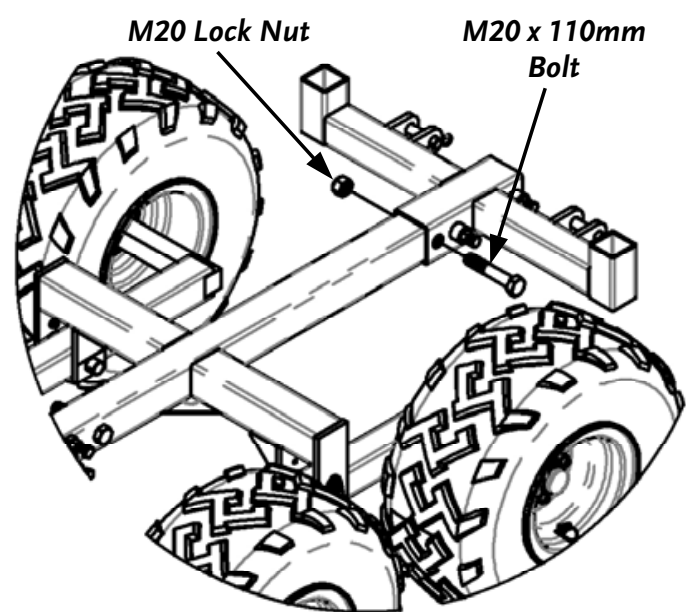

Figure 39

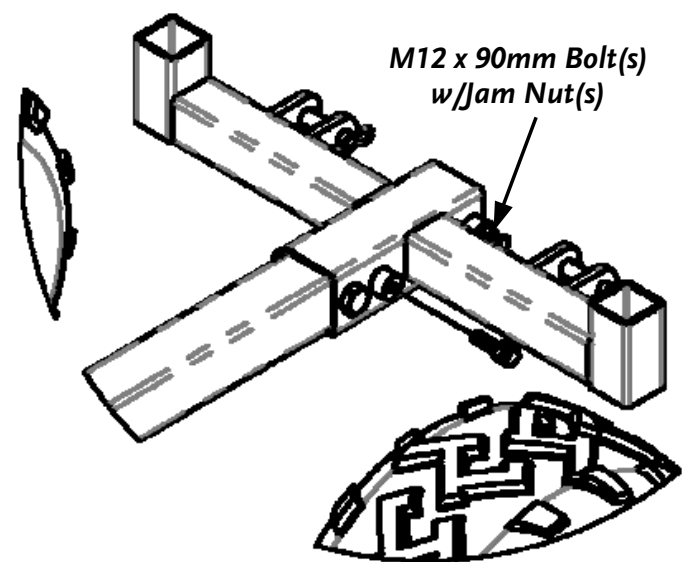

Figure 40

### Installing the Rear Bed Support and Attaching to a Tow Vehicle

#### Tools Needed:

- 18mm and 30mm Socket
- 18mm Wrench
- Adjustable Wrench
- 1/2" Drive Torque Wrench
- 5" Long 1/2" Drive Socket Extension
- 21mm 1/2" Drive Socket

1. Slide the Rear Bed Support (**Figure 38**) onto the Main Frame with the Bosses facing Left.
2. Line up the through Hole in the Rear Support and Main Frame and install the M20 x 110mm Bolt (**Figure 39**) through the Rear Support and Main Frame and secure with the M20 Lock Nut and tighten with a 30mm Socket and Adjustable Wrench.
3. Install two M12 x 90mm Bolts w/Jam Nuts (**Figure 40**) in the Rear Support and tighten the Bolts then the Jam Nuts using an 18mm Socket and 18mm Wrench.

#### ⚠ WARNING

- Make sure your 2" Hitch Ball is correctly tightened to the Receiver and that the Receiver is properly connected to your Towing Vehicle. A loose Ball or Receiver can result in the Trailer detaching from the Tow Vehicle during use.
- A worn, corroded, cracked, or otherwise damaged Hitch Ball can fail while towing. Always inspect your Ball before attaching to your Trailer.
- Always use a 2" Hitch Ball with your Trailer.
- Never operate your Trailer if the Coupler is not locked and the Safety Snap Pin is not installed.
- When the Trailer's Coupler is connected to the Ball and is in the locked position, rock the Tow Bar up and down as well as side-to-side to make sure the Ball is tight to the Coupler. A properly fastened and locked Coupler will raise the rear of the Tow Vehicle when it is pulled upwards without coming off of the Ball.

4. Attach the Trailer to your Tow Vehicle using a 2" Ball, making sure to properly latch the Coupler, and locking it with the supplied Safety Snap Pin (**Figure 41** on page 19). After the Trailer is attached, remove the Wheel Chocks.
5. Loosen the Locking Handles for the Stabilizer Legs and raise them to the highest position for towing. Re-tighten the Locking Handles and rotate the Trailer Jack to the Tow position (**Figure 42** on page 19).
6. Torque the Lug Nuts on each Wheel to 85-90 ft-lbs using a Torque Wrench, a 5" Extension and 21mm Socket.

#### ⚠ WARNING

Make sure all Nuts and Bolts are tight. Inspect all Hardware on your Trailer before proceeding any further.

### Inserting the Log Hauling Extenders

**NOTE:** If you wish to use the Trailer in the Log Hauling configuration initially, please follow these steps, if not please skip to the next section that covers installing the Dump Bed.

1. Insert the Log Cradles (**Figure 43**), with the angled portion of the Cradles facing outwards.
2. Insert the Log Cradle Extensions by first passing the Chain through the Square opening(s) of the Log Cradles (**Figure 43**).
3. Install the Log Cradle Extension Caps (**Figure 43**).

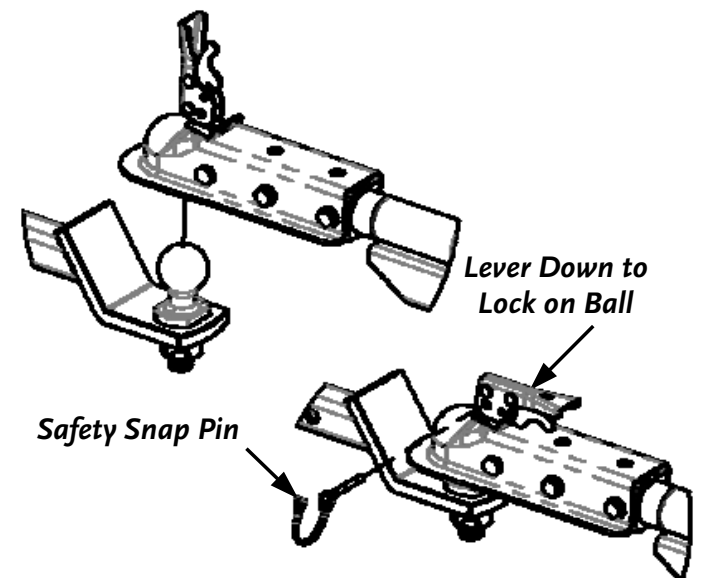

Figure 41

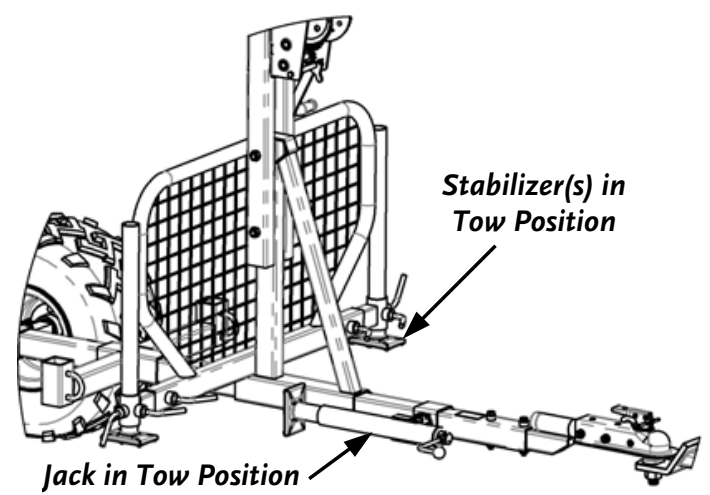

Figure 42

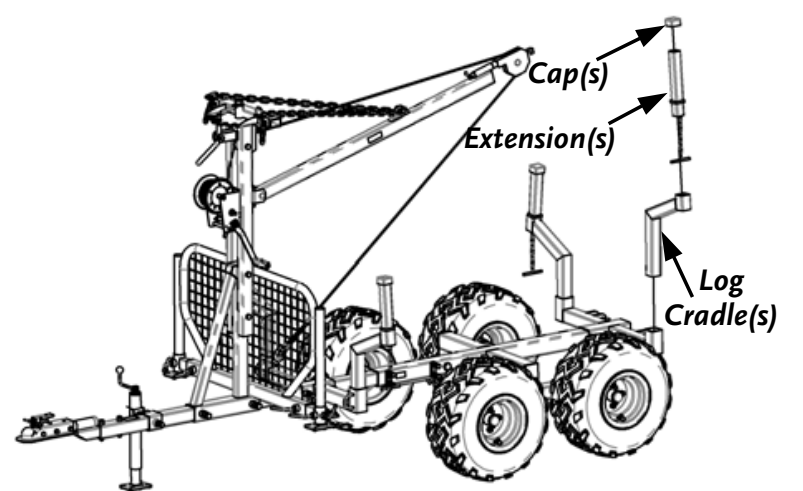

Figure 43

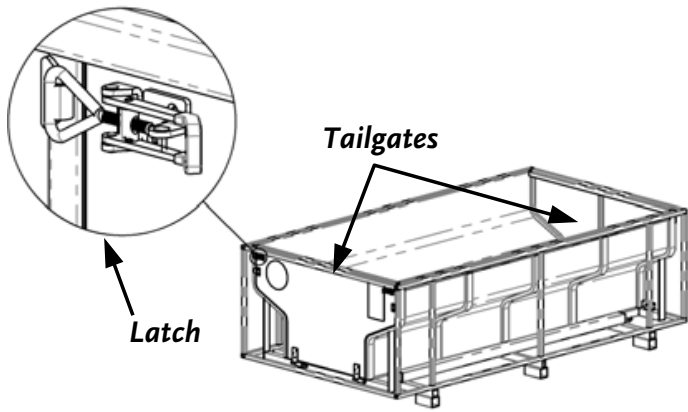

Figure 44

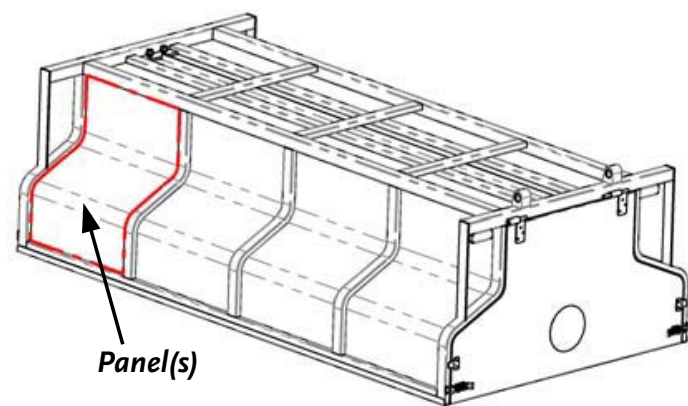

Figure 45

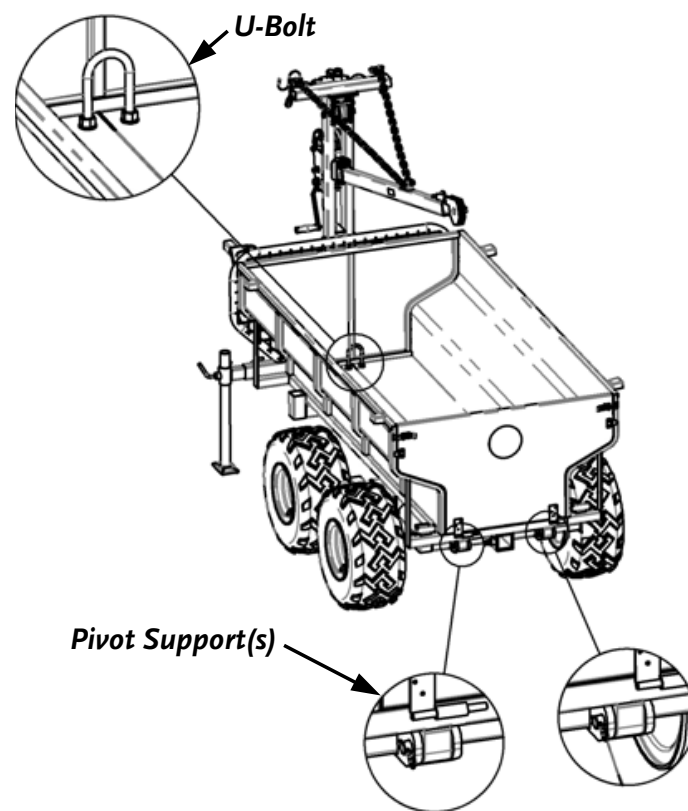

Figure 46

### Removing the Blue Plastic Protective Film and Installing the Dump Bed

Tools Needed:

- Utility Knife
- Protective Goggles or Safety Glasses
- Gloves

#### ⚠ WARNING

- The Bed of the Trailer is very heavy and must be lifted out of the Shipping Crate and on to the Trailer by at least two adults.
- Always be aware of where your Hands and Feet are positioned as they can be crushed if you loose your grip while lifting the Bed from the Shipping Crate.
- Never allow children or pets to play around you, the Bed, Shipping Crate, or Trailer when you are performing these steps.

1. Remove the Bed from the steel-shipping Crate with the assistance of **at least** one other person by lifting the Bed straight up, and out of the Crate by the Tailgates. Make sure all four Latches on the Tailgates are properly latched (**Figure 44**) before lifting the Bed out of the Crate and placing it on the ground.
2. To remove the Blue Plastic Protective Film from the Inside and Outside of the Bed, use your Fingernail, or the point of a Utility Knife to peel up one end of the plastic at the edges of the Bed and begin to peel off the Film.
3. With the assistance of **at least** one other person, turn the Bed over onto its top, to remove the Blue Plastic Film from the exterior and underside of the Bed. Use the Utility Knife to cut around the Black Frame of the Trailer for the individual panels (**Figure 45**). Once you have cut around the individual panels, use the point of the Knife to begin peeling at the edge.
4. With the assistance of **at least** one other person, turn the Bed back over and place the Bed on the Trailer in the orientation shown in **Figure 46**, with the U-Bolt at the front of the Trailer and the Dumping Pivots on the Bed placed between the Pivot Supports on the Rear Bed Support.

**NOTE:** It is recommended to lift the Bed from the Sides to walk the Bed onto the Trailer. It is easier to install the Bed without the Log Cradles and Extensions inserted into the Frame. These are also unnecessary when the Bed is installed.

5. Align the Holes though the Dumping Pivots on the Bed with the ones on the Rear Bed Support and install the two Pivot Pins and Hitch Clips (**Figure 47** on page 21).
6. Attach the Hook from the Winch to the U-Bolt in the Bed (**Figure 48** on page 21).
7. Check and adjust the Tire Pressures to 25-28 PSI prior to use.
8. CONGRATULATIONS! Your DR VERSA TRAILER is now ready to use! See the next Chapter for operating suggestions and tips.

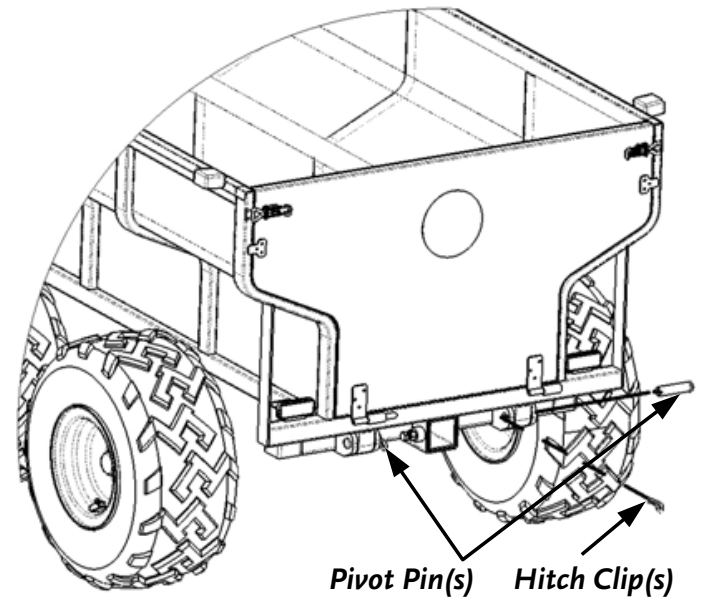

Figure 47

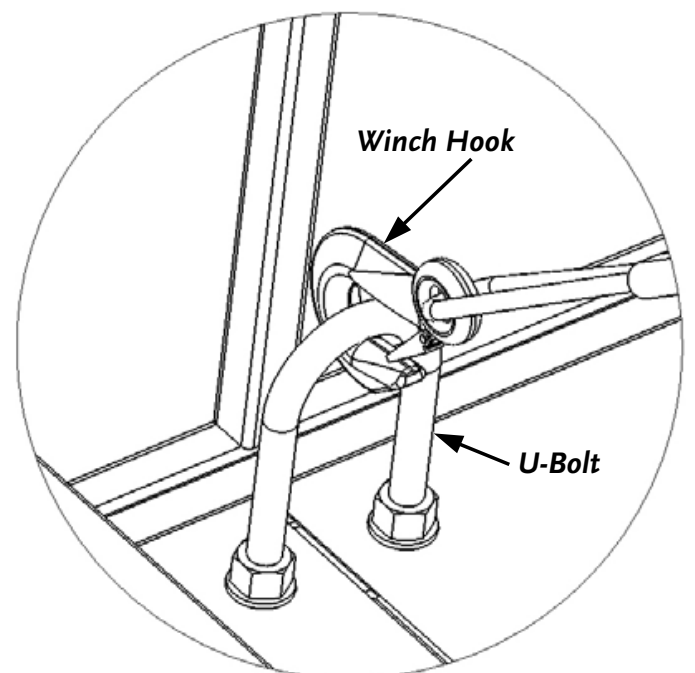

Figure 48

## Chapter 3: Operating The DR VERSA TRAILER

This chapter covers the basic operation procedures for your new DR VERSA TRAILER. It may be helpful to better familiarize yourself with the features of your Trailer by reviewing **Figure 1** in Chapter 2 before beginning the steps outlined in this chapter.

### **! WARNING**

Read and understand the warnings listed in “Chapter 1 General Safety Rules” before operating the DR VERSA TRAILER.

#### **Before You Begin**

- Visually check the Winch Cable for any frays or other damage each time you use the Trailer.
- Inspect the Winch for smooth operation, no binding, pinching or crimping of the Cable.
- Assure that the Tires are properly inflated.
- Assure that the Wheel Lug nuts are properly torqued.
- Assure that the Trailer is securely fastened and properly adjusted to your Tow Vehicle using a 2" Ball and properly latching and locking the Tow Hitch with the Safety Snap Pin.
- Assure that all hardware is tight.
- Inspect the Crane and Boom for any damage or bending.

#### **Loading the Trailer**

### **! WARNING**

- Never load, or unload the Trailer if it is not securely attached to a suitable Tow Vehicle.
- Never load, or unload the Trailer if it is on, or near a slope as the Trailer may tip, or drag the Tow Vehicle down the slope.
- Always securely set the Parking Brake and ensure the Tow Vehicle is in Park before dismounting to load, or unload the Trailer.
- When loading the Trailer it is best to evenly distribute the weight front to rear to provide the proper Tongue Weight. If too much weight is concentrated to the Rear of the Trailer you will cause a negative Tongue Weight, which could lift the rear of the Tow Vehicle, which could cause you to lose control during Towing. Adversely, too much weight at the front of the Trailer can cause too great of a Tongue weight on the Trailer and Lift the front of the Tow Vehicle off the ground, diminishing your ability to effectively turn and stop.
- Load the Weight evenly side to side to avoid overloading the Tires.
- Always keep the Center of Gravity low to improve the stability of the Trailer.
- Always secure any load placed in, or on the Trailer to limit shifting of the cargo as this can cause loss of control of the Trailer and Tow Vehicle. Always use properly sized Straps, Ropes, etc.
- Always follow the Towing instructions and ratings found in your Tow Vehicle's Manual. Familiarize yourself with the Gross Vehicle Weight Rating (GVWR) of your Tow Vehicle, which is the total weight of the load you put in, or on the Trailer, plus the empty weight of the Trailer itself and never exceed this rating.
- Never use the Trailer to transport People, Containers of Hazardous, Flammable, or Explosive Substances.
- If you are using the Dump Bed with the Tailgates installed, always make sure the Latches are properly adjusted and locked.

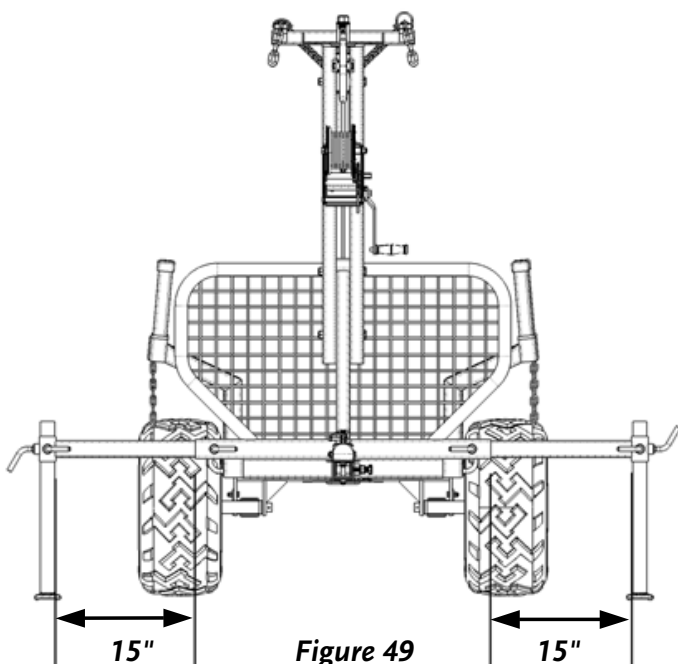

Figure 49

Before loading the Trailer, extend the Outriggers no more than 15" outwards from the end of the Operator Guard (**Figure 49**) and lower the Adjustable Stabilizer Legs to the ground and tighten the Locking Handles. Once you have finished loading the Trailer, raise the Adjustable Stabilizer Legs and retract the Outriggers for travel.

**NOTE:** If you are loading material into the Bed that you wish to dump, make sure the Winch Hook is properly secured to the U-Bolt inside the Bed (**Figure 48**, on page 21).

## Using the Dump Bed

### **⚠ WARNING**

- Never stand in, or under the Bed when dumping material from the Bed.
- Never place anything under the raised bed and always ensure that no other adults, children, or pets are near, or around the Bed when lowering it back into place.
- Never load more than 650 lbs of material into the Bed if you are intending to dump it.

1. The Dump Bed may be used to haul and dump a number of things from dirt, rocks, stones and logs, to name a few. To dump material from the Bed of the Trailer, remove the Rear Tailgate.

**NOTE:** To remove the Tailgate(s) release the Latches on the Tailgate by pulling the Red Handles of the Latches away from the Tailgate. Pivot the Tailgate down and then push the Tailgate to the Left to uncouple the Hinge (**Figure 50**).

2. Once the Tailgate has been removed, use the Winch to raise the Bed to dump the material out.

**NOTE:** The Chains for the Boom need to be adjusted to the ideal length for the Dumping of the Bed. Adjust the length of the Chains so the 10th link of the Chain (from the end of the Chain) is captured and securely pinned in place, with the supplied Hitch Clips, on the Boom Pivot. It is recommended to have the assistance of one other person to support the weight of the Crane while you adjust the length of the Chains individually. Remove one Hitch Clip, adjust the Chain, then re-seat the Chain in the Retainer on the Boom Pivot and re-insert the Hitch Clip (**Figure 51**). Repeat for the other Chain to have the Boom centered on the Trailer and ready for dumping.

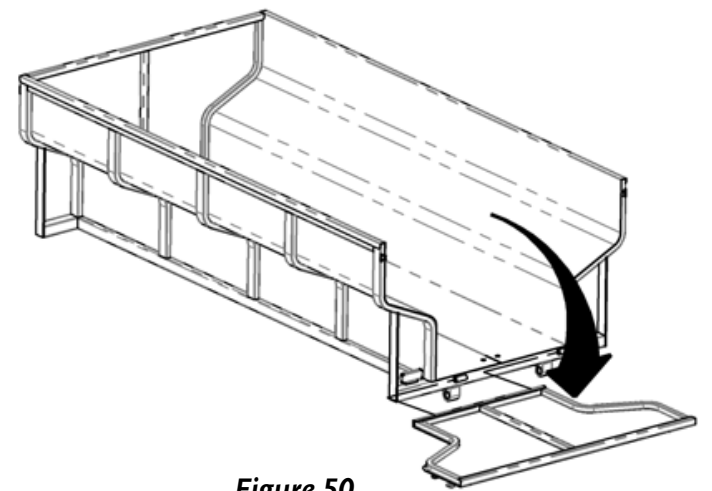

Figure 50

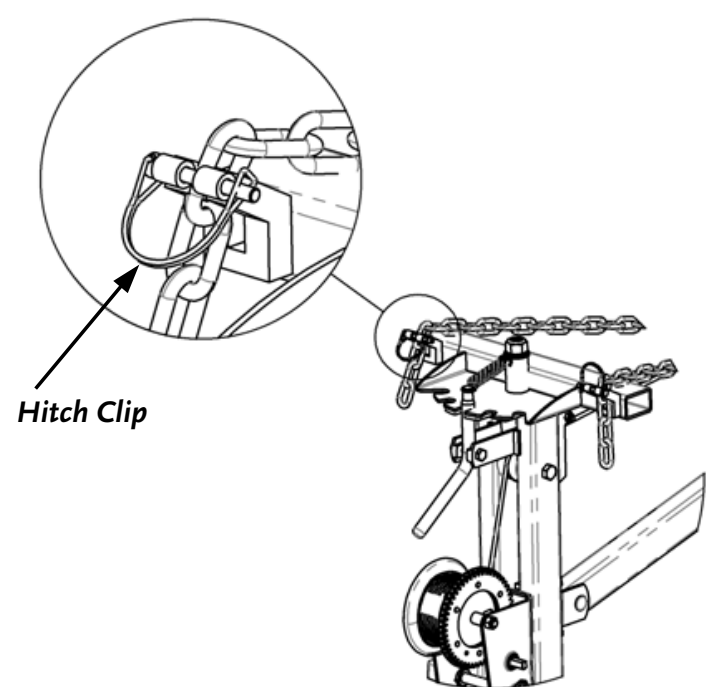

Figure 51

## Using the Winch and Boom to Load Logs onto the Trailer

### ⚠ WARNING

- Always stand on the Crank Handle side of the Winch (**Figure 51**), never directly in line with the Winch Cable, and always behind the Operator Guard! If the Winch Cable is kinked, frayed, or otherwise damaged, do not use it. Replace the Cable immediately.
- Always make sure there are more than 6 complete wraps of the Cable around the Drum of the Winch. Never extend the Cable of the Winch past this point, as it will compromise the strength of the Winch and Cable.
- Never lift more than 440 lbs with the Winch.
- When using the Winch to load a Log or other item on to the Trailer, or into the Bed, never lift it higher than the Frame, or the Bed of the Trailer (if installed). Keep the weight as low as possible.
- When lifting an item on to the Trailer, or into the Bed (if installed), never stand under or near the item being lifted. Always make sure that any bystanders, children, or pets are at least 30 feet away and are behind the Operator Zone.

1. Remove the Bed of the Trailer by removing the Pivot Pins and Hitch Clips that attach the Bed to the Trailer. Slide the Bed to the rear of the Trailer and either stand it up on end, on level ground, or lay it down.

### ⚠ WARNING

Never allow other adults, children, or pets to play around a Bed that is stood up on end as they could contact it and knock it over. If you are intending to store the Bed stood on end, secure it with adequate ropes or straps to ensure it cannot easily topple.

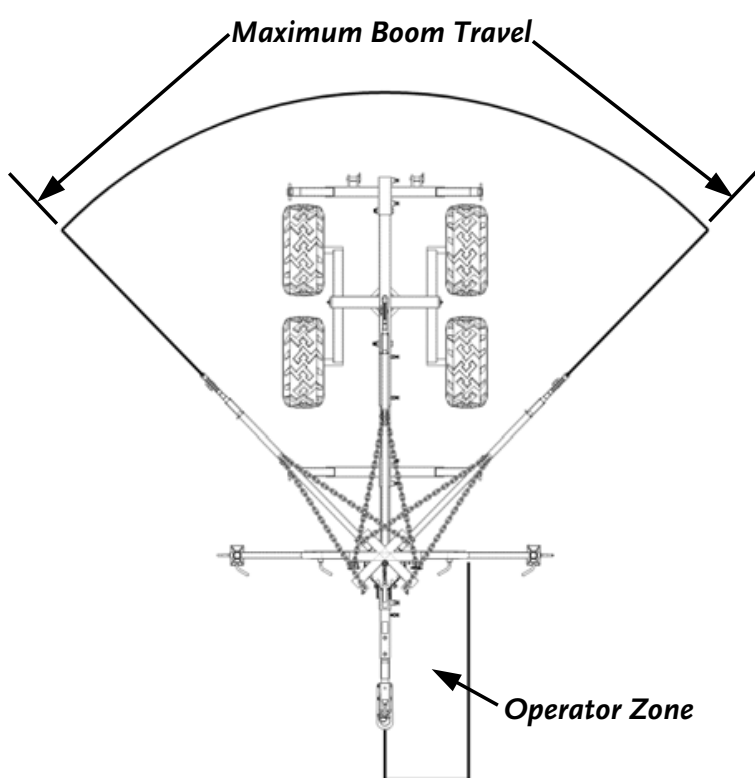

Figure 52

2. Use the Winch to unload the Logs by rotating the Boom to either side of the Dump Bed by using the Boom Swivel (**Figure 1** on page 6). To rotate the Boom, push the Pivot Lock Handle inwards until it pivots out to clear the Boom Pivot. Rotate the Crane in the desired direction and release the Pivot Lock Handle so it seats itself back into one of the Locking Detents on the Boom Pivot. Refer to **Figure 52** for the maximum Boom travel and Operator position.
3. Extend the Outriggers and Stabilizer Legs as described in **Loading the Trailer** on page 22 and use the Winch with a Choker Chain (sold separately) to drag, or lift Logs on to the Trailer. Be sure to securely attach the Choker Chain to the Log by wrapping the Chain tightly around the Log once, then through the Ring on the Choker Chain. Connect the Winch Hook to a Chain Link on the Choker Chain that is at least 2 Links through the Ring of the Choker Chain. The Choker Chain should tighten itself around the Log as you begin to slowly pull the Log toward the Trailer with the Winch.

### Using the Log Cradles and Extensions

1. Remove the Dump Bed by performing steps 4 & 5 on page 20 in the reverse order.
2. Slide the four Log Cradles into the Slots in the Main Frame (**Figure 43** on page 19). Depending on the height of the Logs in the Trailer, you may want to use the Log Cradle Extensions by sliding them into the Log Cradles (**Figure 43** on page 19).

### Adjusting the Tailgate Latches

Overtime you may need to adjust your Tailgate Latches. To do so, open the Latch (**Figure 53**) and thread the Latching Arm inwards, or outwards to adjust the length of the Latching Arm (**Figure 54**).

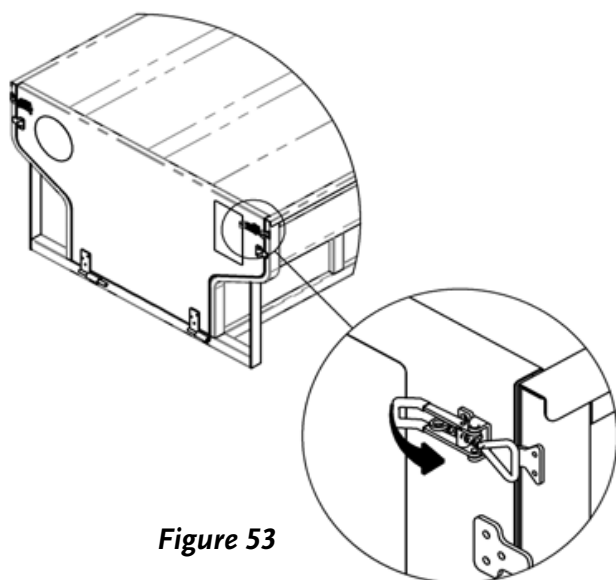

Figure 53

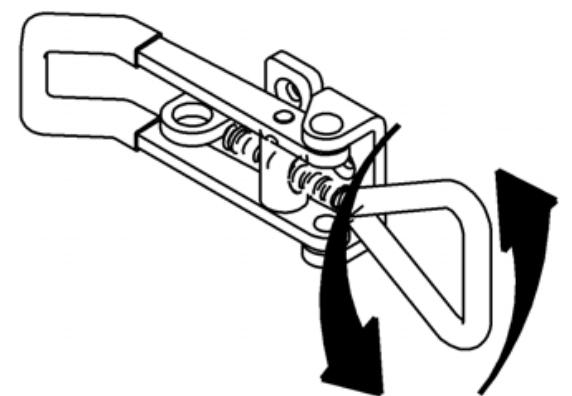

Figure 54



## Chapter 4: Maintaining The DR VERSA TRAILER

Regular maintenance is the way to ensure the best performance and long life of your Trailer. Please refer to this manual for maintenance procedures.

### Regular Maintenance Checklist

#### **WARNING**

- Before inspecting, or performing any Maintenance make sure the Tow Vehicle is properly Parked on Level Ground and the Wheels of the Trailer are Chocked.
- Never position yourself, or anyone else under the Bed when it is raised.

PROCEDURE	BEFORE EACH USE	EVERY 6 MONTHS
Check General Equipment Condition	▲	
Check the Condition of the Winch Cable for any wear	▲	
Inspect the Chains for any deformed or broken links	▲	
Inspect the Boom and Crane for any bends, cracks, or signs of fatigue	▲	
Inspect the rollers and pulleys for cracks, breakages, bends or other severe signs of wear	▲	
Inspect the Tow Hitch Coupler and the 2" Ball	▲	
Lubricate the Winch (per the Winch instructions, shipped with the Winch)		▲
Check all Hardware to ensure everything is properly tightened	▲	
Check Tire Pressure	▲	
Torque Wheel Lug Nuts	▲	
Grease the Axle Pivot Pins, Swivel of the Tow Hitch, the Receiver and the 2" Ball	▲	
Grease the Wheel Bearings <i><b>NOTE:</b> If the Trailer is submerged to the Wheel Bearings, or is exposed to large amounts of Debris, grease the Wheel Bearings sooner to avoid damage.</i>		▲

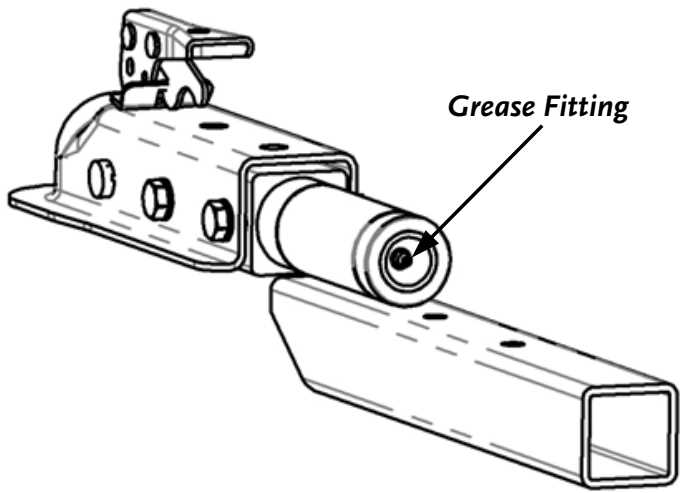

Figure 55

### Greasing the Tow Ball, Tow Hitch, and Grease Fittings

Your DR VERSA TRAILER'S Wheel Bearings were greased at the Factory. Prior to using your Trailer for the first time, you need to lubricate the Axle Pivot Pins, Swivel of the Tow Hitch, the Tow Hitch Coupler, and the 2" Ball you will be using. You should also periodically lubricate the Axle Pivot Pins, Tow Hitch Swivel, Tow Hitch Coupler, and 2" Ball to reduce wear and rust on these components.

#### Tools and Supplies Needed:

- Flexible hose grease gun
- Lithium grease
- Clean cloth

1. Wipe all dirt, etc., from the Grease Fitting(s) with a clean cloth.
2. Apply enough quality general-purpose lithium grease with a hand-pumped grease gun to each Axle Pivot Pin and Tow Hitch Swivel Zerk Fitting, so a small amount of Grease comes out of the Fitting(s) (**Figures 55 & 56**)
3. Apply the grease to your 2" Tow Ball to reduce friction on the Tow Hitch Coupler and to help prevent rusting and seizing of the ball to the Coupler.
4. Apply the grease to the Pivot Pins of the Latch on the Coupler and to the underside of the Coupler (**Figure 57**).

**TIP:** The Tow Hitch is designed to rotate 360° to ease greasing of the underside of the coupler.

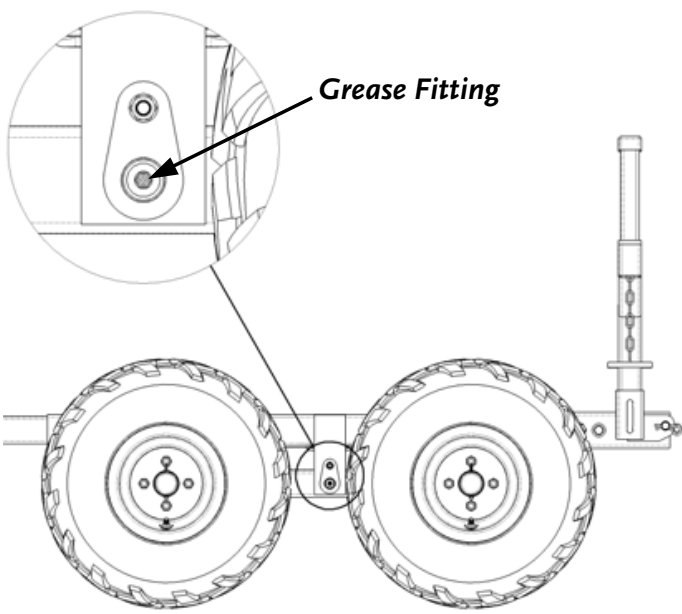

Figure 56

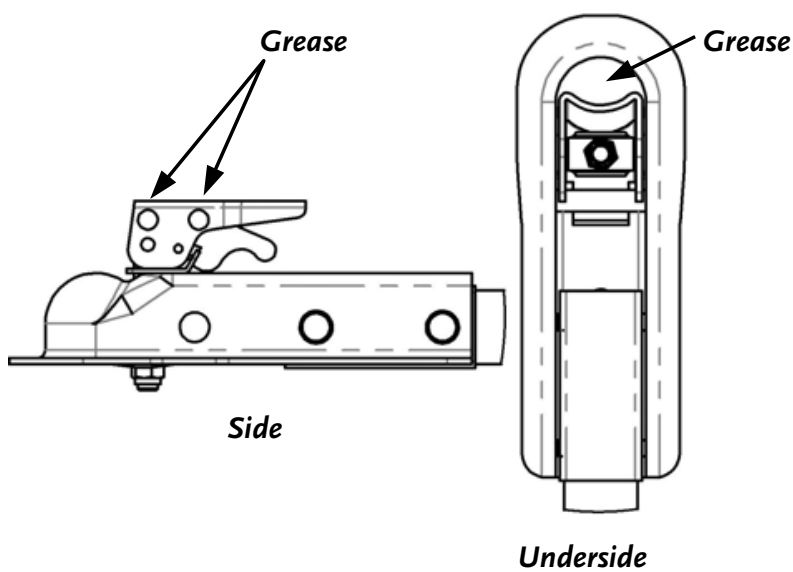

Figure 57

## Wheel and Lug Nuts

---

### **WARNING**

- Lug Nuts and Wheel Studs are prone to damage if loose. Lug Nuts are prone to loosening after installation. The deformation of the Wheel Rim where the Lug Nut seats will cause the Nut(s) to loosen and could result in a Wheel coming off of the Trailer. Check the Lug Nuts individually for tightness before each use, or after a Wheel has been replaced on the Trailer.
  - Inspect the Lug Nuts to ensure all are present and tight before operation. Never operate the Trailer if a Lug Nut is missing, or is not properly torqued.
  - Always torque the Lug Nuts to 85-90 ft-lbs in an alternating pattern.
  - Inspect the Wheel Studs for damage. Never operate the Trailer with a damaged or missing Wheel Stud.
  - To check the Wheel Bearings of your Trailer, jack the Trailer off of the ground and check the Wheels for side-to-side looseness. If the Wheels are loose, or Spin with a Wobble, the Bearings must be replaced.
  - Before operating the Trailer always check the Tire Pressures of the Trailers Tires with no load in the Bed, or on the Trailer. They should be adjusted to 25-28 PSI and never in excess of 36 PSI.
  - Inspect the Wheels for damage, or bending. Never operate the Trailer if a Wheel is damaged; replace the Wheel immediately.
  - Inspect the Tires for damage or cuts. Even if the Tire is not leaking air, damage, or cuts could lead to a blow out when the Trailer is loaded. Never operate the Trailer if a Tire is damaged; replace the Tire immediately.
  - Inspect all Valve Stems of the Tires. If the Valve Stems are damaged, do not use the Trailer; have the Valve Stem(s) replaced, or replace the Wheel(s) and Tire(s).
  - Clear all debris from the area of the Valve Stem(s) before operation to avoid damaging the Stem(s).
-

## Chapter 5: Troubleshooting

---

Most problems are easy to fix. Consult the Troubleshooting Table below for common problems and their solutions. If you continue to experience problems, contact us at [www.DRpower.com](http://www.DRpower.com) or call toll-free 1-800-DR-OWNER (376-9637) for support.

### **WARNING**

Shut down the Tow Vehicle Engine and apply the Parking Brake before performing any maintenance procedure or inspection on the DR VERSA TRAILER.

---

#### **Troubleshooting Table**

<b>SYMPTOM</b>	<b>POSSIBLE CAUSE</b>
<i>Bed hits the Crane while dumping.</i>	<i>⇒ Use Chain Link 10. ⇒ Reposition the Operator Guard.</i>
<i>Bed does not sit on the Frame when lowered.</i>	<i>⇒ Be sure the Bed is centered and not sitting on a Log Cradle.</i>
<i>Winch Handle hits the Crane.</i>	<i>⇒ Rotate the Crane Pivot one position towards center or adjust the Chains to pull up the Boom.</i>
<i>Winch is hot.</i>	<i>⇒ This is normal while lowering the Boom. This may also lead to a hesitation of the Winch so allow Winch to cool.</i>

**NOTES:**

## Chapter 6: Parts Lists and Schematic Diagrams

---

### Parts List – DR VERSA TRAILER Dump Bed Assembly

**NOTE:** Part numbers listed are available through DR Power Equipment.

<u>Ref#</u>	<u>Part#</u>	<u>Description</u>	<u>Ref#</u>	<u>Part#</u>	<u>Description</u>
01	29984	Rear Tailgate	<u>Not Illustrated</u>		
02	29985	Front Tailgate	303381		Standard Warranty
03	30240	Hex Nut, Heavy, M12-1.75, Class 8, ZP	303371		Safety & Operating Instructions Manual
04	30265	U-Bolt, 50mm x M12-1.75			
05	30252	Washer, M12			
06	30253	Lock Nut, Nylon, M12-1.75			
07	29979	Dump Bed			
08	30285	Reflector			
09	27722	Dump Bed Pin			
10	16003	Hitch Clip Pin, 1/2" to 9/16", .12" Wire			
11	30287	Tailgate Tab Stop			
12	29981	Tailgate Latch			
13	29982	Tailgate Long Hinge			
14	29983	Tailgate Short Hinge			
15	23494	DR Logo Label, 6" Round			
16	29396	Operator Label			

**Schematic – DR VERSA TRAILER Dump Bed Assembly**

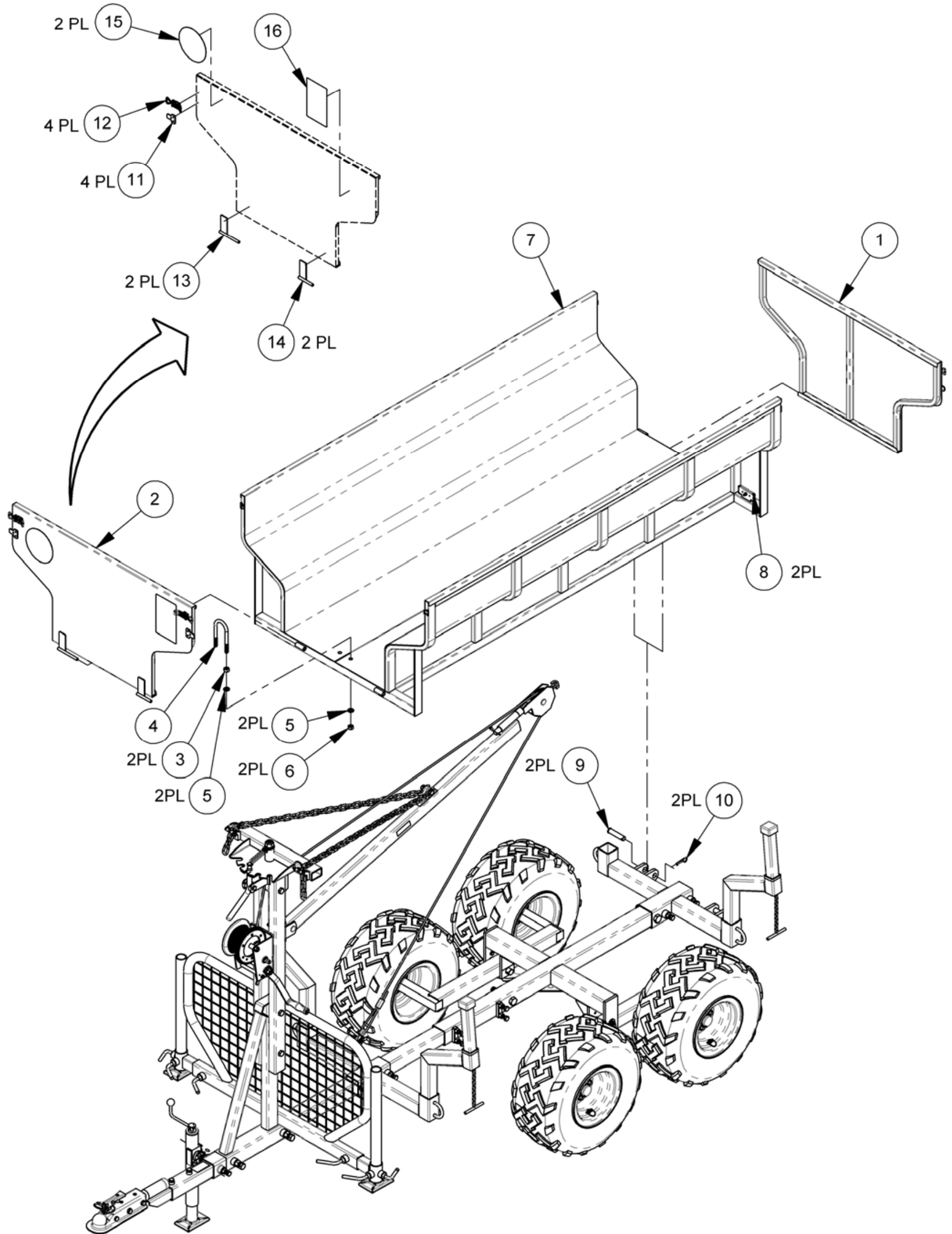

120305

**Parts List and Schematic – DR VERSA TRAILER Crane and Boom Assembly**

**NOTE:** Part numbers listed are available through DR Power Equipment.

<u>Ref#</u>	<u>Part#</u>	<u>Description</u>	<u>Ref#</u>	<u>Part#</u>	<u>Description</u>
01	29965	Front Bed Support	23	16003	Hitch Clip Pin, 1/2" to 9/16", .12" Wire
02	29973	Crane Pivot Lock	24	30260	Bolt, HHCS, M8-1.25 x 100, Class 8, ZP
04	29986	Manual Winch w/Cable	25	30263	Bolt, HHCS, M10-1.5 x 55, Class 10, ZP
05	30264	Winch Cable, 1/4" x 25'	26	30255	Bolt, HHCS, M16-2 x 110, Class 10, ZP
06	30269	Crane Boom Subassembly	27	30254	Lock Nut, Nylon, M16-2
07	30275	Safety Snap Pin, 6.25 x 55mm	28	30282	Washer, M20
08	30239	Bolt, HHCS, M12-1.75 x 50mm Class 8, ZP	29	29977	Boom Crane
09	30240	Hex Nut, Heavy, M12-1.75, Class 8, ZP	30	27734	Boom Pulley Pin
10	30262	Lock Nut, Nylon, M14-2	31	16003	Hitch Clip Pin, 1/2" to 9/16", .12" Wire
11	30261	Bolt, HHCS, M14-2 x 140, Class 8, ZP	32	27717	Boom Pulley Bracket
12	30257	Pivot Lock Spring	33	30239	Bolt, HHCS, M12-1.75 x 50, Class 8, ZP
13	30249	Lock Nut, Nylon, M10-1.5	34	27738	Boom Chain
14	30281	Bolt, HHCS, M10-1.5 x 25, Class 10, ZP	35	27721	Boom Pulley, 104mm
15	29974	Pivot Lock Handle	36	29398	Load Rating Label
16	30256	Pivot Lock Tab Spring	37	30252	Washer, M12
17	27720	Lock Nut, Nylon, M20-2.5	38	30253	Lock Nut, Nylon, M12-1.75
18	30259	Fairlead Roller	39	29972	Vertical Crane Support
19	30246	Lock Nut, Nylon, M8-1.25	40	29975	Cable Roller, 55mm
20	30249	Lock Nut, Nylon, M10-1.5	41	30261	Bolt, HHCS, M14-2 x 140, Class 8, ZP
21	29976	Boom Crane Pivot	42	30262	Lock Nut, Nylon, M14-2
22	30258	Boom Pivot Pin			



**Schematic – DR VERSA TRAILER Crane and Boom Assembly**

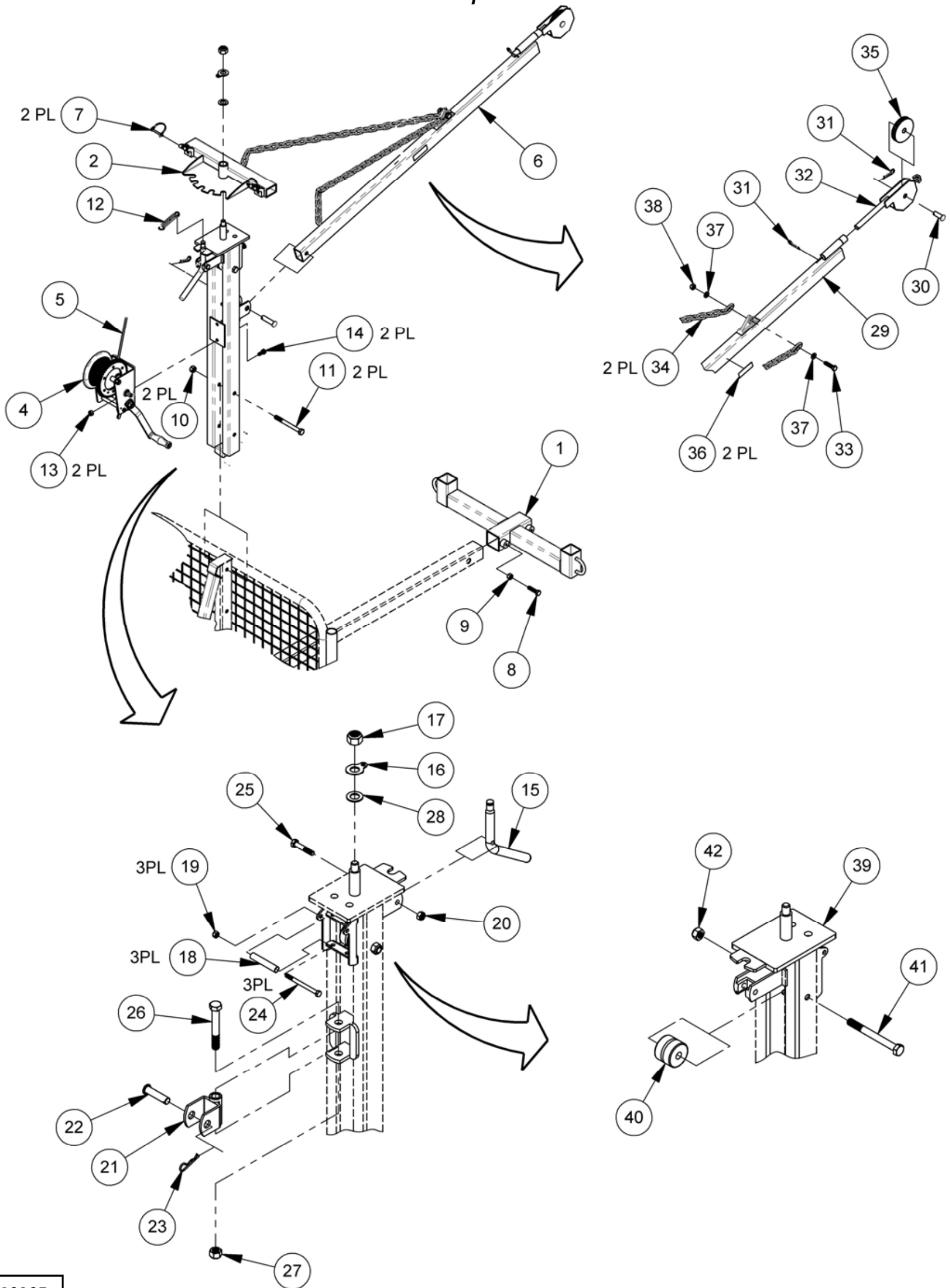

120305

## **Parts List – DR VERSA TRAILER Main Frame and Axle Assembly**

**NOTE:** Part numbers listed are available through DR Power Equipment.

<b>Ref#</b>	<b>Part#</b>	<b>Description</b>
01	30271	Tow Bar w/Labels
02	29958	Axle and Hub Assembly
03	29964	Wheel and Tire Assembly, Off Road
04	30244	Axle Pivot Pin
05	27720	Lock Nut, Nylon, M20-2.5
06	27719	Bolt, M20 x 110
07	29978	Lug Nut
08	30239	Bolt, HHCS, M12-1.75 x 50, Class 8, ZP
09	30240	Hex Nut, Heavy, M12-1.75, Class 8, ZP
10	30245	Bolt, HHCS, M8-1.25 x 30, Class 8, ZP
11	30246	Lock Nut, Nylon, M8-1.25
12	30247	Washer, M8
13	29960	Wheel Stud
14	29961	Wheel Dust Cap
15	30242	Taper Roller Bearing, 30206M
16	30241	Taper Roller Bearing, 30204M
17	25311	Cotter Pin, 3/16" x 2.5"
18	30243	Hex Nut, Slot, M18-1.5, Class 8, ZP
19	29962	Axle
20	29959	Wheel Hub

### **Not Illustrated:**

25311 Cotter Pin, 3/16" x 2-1/2"

**Schematic – DR VERSA TRAILER Main Frame and Axle Assembly**

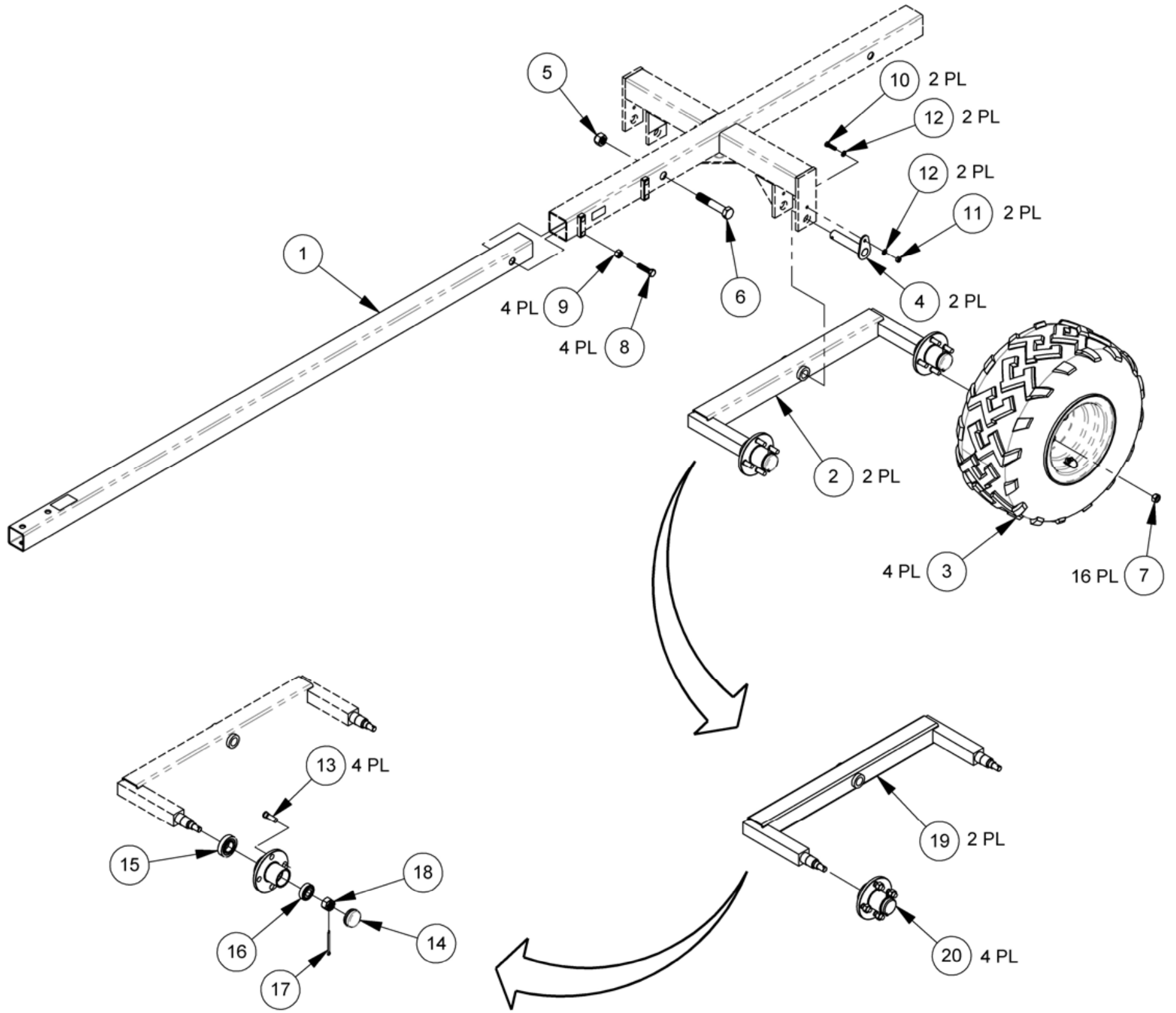

120305

## **Parts List – DR VERSA TRAILER Operator Guard, Trailer Jack, Rear Bed Support, and Pivoting Tow Hitch**

**NOTE:** Part numbers listed are available through DR Power Equipment.

<b>Ref#</b>	<b>Part#</b>	<b>Description</b>
01	27724	Ball Coupler, 2"
02	29971	Operator Guard
03	27715	Stabilizer Bracket
04	27716	Stabilizer Leg
05	27718	Trailer Jack
06	30284	Tow Hitch Spacer
07	27733	Stabilizer Lock Handle
08	30239	Bolt, HHCS, M12-1.75 x 50, Class 8, ZP
09	30240	Hex Nut, Heavy, M12-1.75, Class 8, ZP
10	30251	Bolt, HHCS, M10-1.5 x 90, Class 10, ZP
11	30249	Lock Nut, Nylon, M10-1.5
12	30238	Bolt, HHCS, M16-2 x 50, Class 8, ZP
13	30237	Hex Nut, Heavy, M16-2, Class 8, ZP
14	30250	Washer, M10
15	29966	Log Cradle
16	29969	Rear Bed Support
17	29967	Log Cradle Extension
18	27720	Lock Nut, Nylon, M20-2.5
19	27719	Bolt, M20 x 110
20	30239	Bolt, HHCS, M12-1.75 x 50, Class 8, ZP
21	30240	Hex Nut, Heavy, M12-1.75, Class 8, ZP
22	29968	Box Tubing Cap, 40 x 40mm
23	29970	Pivoting Tow Hitch
24	27724	Ball Coupler, 2"
25	30249	Lock Nut, Nylon, M10-1.5
26	30250	Washer, M10
27	30248	Bolt, HHCS, M10-1.5 x 80, Class 10, ZP

**Schematic – DR VERSA TRAILER Operator Guard, Trailer Jack, Rear Bed Support, and Pivoting Tow Hitch**

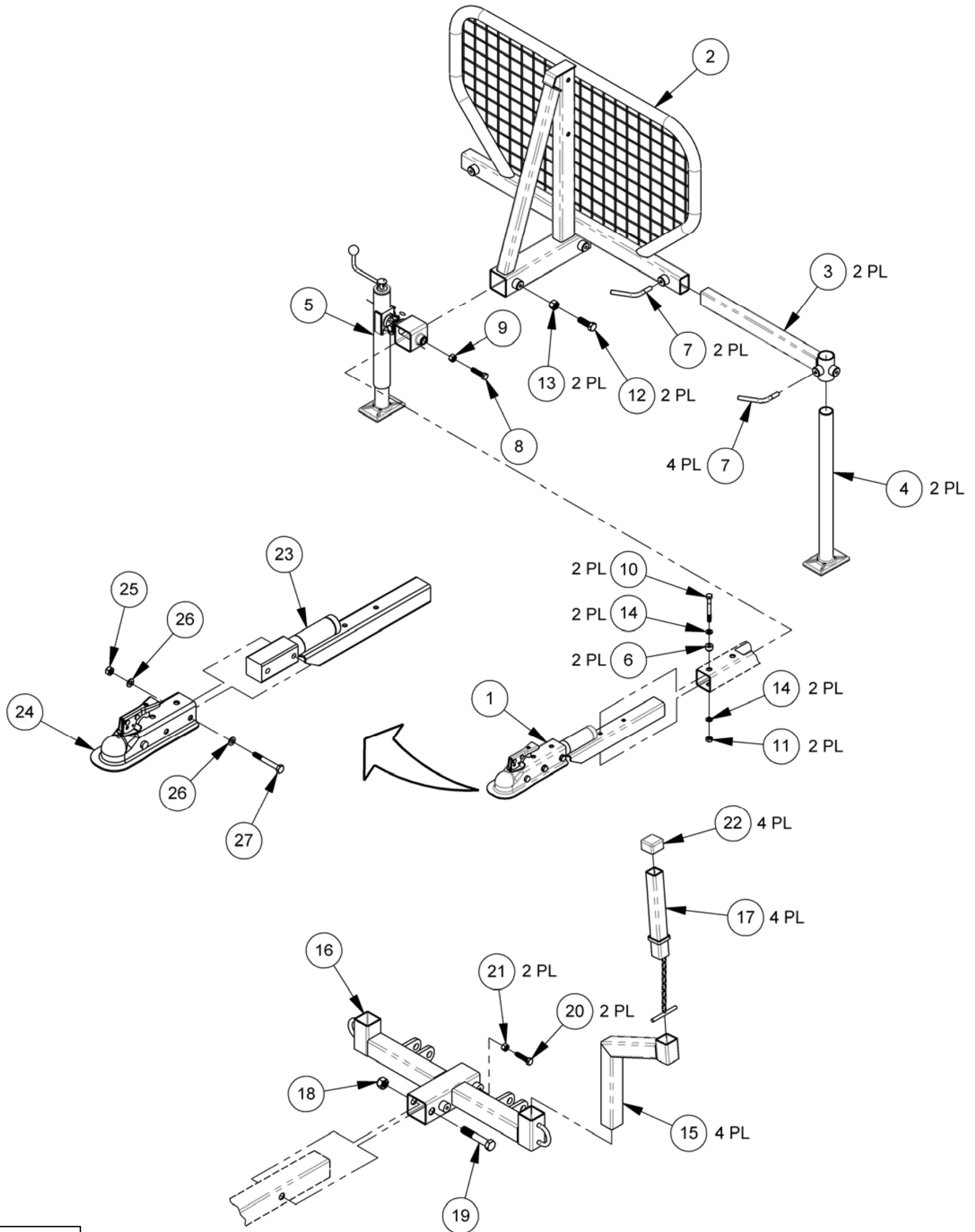

120305

### ***Daily Checklist for the DR VERSA TRAILER***

To help maintain your DR VERSA TRAILER for optimum performance, we recommend you follow this checklist each time you use your Trailer.

---

#### **! WARNING**

Before performing any maintenance procedure or inspection, stop the Tow Vehicle Engine and set the Parking Brake.

---

- Check the general condition of the Trailer, e.g.; nuts, bolts, welds, etc.
- Check the Condition of the Winch Cable for any wear.
- Inspect the Chains for any deformed or broken links.
- Inspect the Boom and Crane for any bends, cracks, or signs of fatigue.
- Inspect the rollers and pulleys for cracks, breakages, bends, or other severe signs of wear.
- Inspect the Tow Hitch Coupler and the 2" Ball.
- Check all Hardware to ensure everything is properly tightened.
- Check Tire Pressure.
- Torque Wheel Lug Nuts.
- Grease the Axle Pivot Pins, Swivel of the Tow Hitch, the Receiver, and the 2" Ball.

### ***End of Season and Storage***

---

#### **! WARNING**

Before performing any maintenance procedure or inspection, stop the Tow Vehicle Engine and set the Parking Brake.

---

- Clean the exterior of the unit to remove all dirt, grease, and any other foreign material. To prevent rust, touch up painted surfaces that have been scratched or chipped.
- Be sure all nuts, bolts, and screws are securely fastened.
- If possible, store the DR VERSA TRAILER in a dry, protected place. If it is necessary to store the Trailer outside, cover the Trailer with a suitable protective cover that does not retain moisture. Do not use plastic as this material cannot breathe; it also allows condensation to form, which will cause your Trailer to rust.



---

75 MEIGS ROAD, P.O. BOX 25, VERGENNES, VERMONT 05491

---