

# DR<sup>®</sup> PREMIER LEAF and LAWN VACUUM



## SAFETY & OPERATING INSTRUCTIONS



**! WARNING!**

**READ AND UNDERSTAND THIS MANUAL AND ALL INSTRUCTIONS BEFORE OPERATING THIS VACUUM**

# THANK YOU!

And congratulations on your purchase of a new DR LEAF and LAWN VACUUM!

We have done our utmost to ensure that your DR LEAF and LAWN VACUUM will be one of the most trouble-free and satisfying pieces of equipment you have ever owned. Please let us know of any questions or problems you may have. We want to answer or correct them as quickly as possible. When you do call, please have your order number, or serial number handy. **For technical assistance, please call Toll-Free 1-800-DR-OWNER (376-9637) and one of our Technical Support Representatives will be happy to help you.** We also hope to hear from you on how much you like your new helper.

And, please tell your friends about your new DR LEAF and LAWN VACUUM! Having DR Owners spread the word about our products and our way of doing business is the best advertising we can have, and the best way to help us provide even better service in the years to come.

Thanks once again!



for all of us at  
Country Home Products, Inc.

**SALES MANAGER**

**COPYRIGHT**

©2005 Country Home Products, Inc. All rights reserved.



DR® Power Equipment  
*A division of Country Home Products®*  
127 Meigs Road  
Vergennes, VT 05491

*Toll-free phone:* 1-800-DR-OWNER (376-9637)  
*Fax:* 1-802-877-1213  
*Web site:* [www.dr-owner.com](http://www.dr-owner.com)

# Table of Contents

CHAPTER 1.....	1
INTRODUCING THE DR PREMIER LEAF and LAWN VACUUM.....	1
Conventions used in this manual .....	1
CHAPTER 2.....	2
GENERAL SAFETY RULES.....	2
Labels .....	2
Protecting Yourself and Those Around You .....	4
Operating the Vacuum Safely.....	4
Slope Operation.....	6
Safety for Children .....	6
Safety with Gasoline-Powered Machines .....	7
A Note to All Users .....	8
Additional Information and Potential Changes.....	8
CHAPTER 3.....	9
SETTING UP YOUR DR LEAF AND LAWN VACUUM.....	9
DR LEAF and LAWN VACUUM Controls and Features .....	10
Unpacking and Assembling the Machine.....	11
Attaching Hardware Description.....	12
Opening the Shipping Container .....	13
Tire Pressure Check .....	14
Tilt Bed Installation.....	15
Collector Box Installation .....	16
Blower Exit Elbow Assembly Installation .....	18
Connecting the Collector Box Inlet Hose to the Blower Exit Elbow Assembly.....	18
Universal Hitch Plate Installation .....	19
Connecting the DR LEAF and LAWN VACUUM to your Lawn Tractor.....	20
Lawn Deck Adapter Installation .....	21
Connecting the Blower Inlet Vacuum Hose to the Hose Adapter.....	23
Connecting the Battery Wire (Electric-Starting Models Only) .....	24
Adding the Engine Oil and Gasoline.....	25
CHAPTER 4.....	26
OPERATING YOUR DR LEAF AND LAWN VACUUM .....	26
Before Starting the Engine.....	26
Starting and Stopping.....	26
Operating Safety .....	27
Towing the DR LEAF and LAWN VACUUM.....	28
Towing Safety.....	28
Slopes and Uneven Terrain .....	29
Operating the Chipper.....	30
Dumping.....	32
Use as a Trailer .....	33
LEAF and LAWN VACUUM Tips.....	34
CHAPTER 5.....	35
MAINTAINING THE DR LEAF AND LAWN VACUUM.....	35
Regular Maintenance Checklist.....	35
Lubrication .....	36
Removing and Replacing the Engine Oil .....	37
Battery Care (For Electric-Starting Models Only) .....	38
Charging the Battery .....	38
Removing and Replacing the Blower Hoses.....	39

Removing and Replacing the Blower Exit Elbow .....	40
Removing and Replacing the Chipper Blade .....	41
Removing the Blower/Chipper Engine Unit .....	42
End of Season and Storage .....	43
 CHAPTER 6.....	 44
TROUBLESHOOTING.....	44
Troubleshooting Table.....	44
 CHAPTER 7.....	 48
PARTS LISTS, SCHEMATIC DIAGRAMS AND WARRANTY.....	48
Parts List - Trailer Assembly.....	48
Schematic Diagram - Trailer Assembly.....	49
Parts List - Blower/Chipper Assembly .....	50
Schematic Diagram - Blower/Chipper Assembly .....	51
Parts List - Centrifugal Separator, Hose and Blower Exit Elbow Assembly .....	52
Schematic Diagram - Centrifugal Separator, Hose and Blower Exit Elbow Assembly .....	53
Parts List - Tilt Bed Assembly.....	54
Schematic Diagram - Tilt Bed Assembly.....	55
Parts List - Side and Rear Panel Assembly.....	56
Schematic Diagram - Side and Rear Panel Assembly .....	57
Parts List - Front Panel Assembly .....	58
Schematic Diagram - Front Panel Assembly .....	58
Warranty.....	61

## CHAPTER 1

# INTRODUCING THE DR PREMIER LEAF and LAWN VACUUM

This manual will help you set up and safely operate your new DR PREMIER LEAF and LAWN VACUUM. Careful adherence to the safety and operating instructions in this manual will ensure many years of productive use.

Please let us know of any questions you may have. We want to answer them as quickly as possible. When you do call, please have your order number, or serial number handy. **For technical assistance, please call Toll-Free 1-800-DR-OWNER (376-9637) and one of our Technical Support Representatives will be happy to help you.**

### *Conventions used in this manual*

---

#### **WARNING!**

THIS INDICATES A HAZARDOUS SITUATION, WHICH, IF NOT AVOIDED, COULD RESULT IN DEATH OR SERIOUS INJURY.

---

---

#### **CAUTION!**

THIS INDICATES A HAZARDOUS SITUATION, WHICH, IF NOT AVOIDED, COULD RESULT IN MINOR OR MODERATE INJURY.

---

---

#### **NOTICE!**

THIS INFORMATION IS IMPORTANT IN THE PROPER USE OF YOUR MACHINE. FAILURE TO FOLLOW THIS INSTRUCTION COULD RESULT IN DAMAGE TO YOUR MACHINE OR PROPERTY.

---

**Tip:** This is a helpful hint to guide you in getting the most out of your DR LEAF and LAWN VACUUM.

**Tools Needed:** This indicates you will need a special tool to perform a maintenance function on your Vacuum.

**NOTE:** *This information may be helpful to you.*

If you are ever unsure about an action you are about to take, don't do it, contact Country Home Products' toll-free support at 1-800-DR-OWNER (376-9637) for help or information.

## GENERAL SAFETY RULES

### **! WARNING!**

**READ THIS SAFETY AND OPERATING MANUAL BEFORE YOU USE THE DR LEAF AND LAWN VACUUM. BECOME FAMILIAR WITH THE SERVICE RECOMMENDATIONS TO ENSURE THE BEST PERFORMANCE FROM YOUR VACUUM.**

### *Labels*

Your DR LEAF and LAWN VACUUM carries prominent labels as reminders for its proper and safe use. Shown below are copies of all the labels that appear on the equipment. Take a moment to study them and make a note of their location on your DR LEAF and LAWN VACUUM as you assemble and *before* you operate the machine. Replace damaged or missing safety and information labels immediately.



Read the instruction manual thoroughly before using this machine.



Use approved eye protection when operating this machine.



Rotating Blades: Keep hands out of chipper and blower inlet as well as the lawn deck when the engines are running.



Do not allow people or pets near the machine when it is operating.



NEVER insert metal, glass, or objects other than wood into the chipper hopper. Be careful when vacuuming to avoid these materials.



On electric start models, shut off the engine by moving the Throttle to the STOP position; the Key is for starting ONLY. #193231

**WARNING: Add Oil Before Starting Engine**



Make sure you add oil before starting the engine; the unit is shipped without oil. Fill the oil reservoir slowly to make sure you don't overfill it. #12781

Do not touch and keep combustible substances away from the engine when it is hot. #18887

**DR® LEAF and LAWN VACUUM**

**Safety**

A row of six small icons: a person reading a manual, a hand holding a spark plug wire, a hand holding a vacuum hose, a hand holding a vacuum nozzle, a person carrying a vacuum, and a person with a vacuum nearby.

- Read your manual carefully.
- Always shut off engine and remove spark plug wire before servicing your machine.
- Never open the collector box while the vacuum is running.
- Never carry passengers.
- Always use a stick to clear hose blockages.

**Starting / Stopping**

- Check engine oil level before each use.
- Move choke lever to CHOKE position. Move throttle to FAST position.
- Pull the recoil handle with a long, slow stroke.
- Move choke to RUN position.
- Move lever to STOP position to stop engine.

**Operating**

- Do not use on slopes greater than 20 degrees.
- Hold the hand vacuum nozzle slightly above material to be vacuumed. Avoid stones, glass & hard objects.
- Do not chip branches larger than 2 inches in diameter.
- Be alert to changes in terrain and check behind you before backing up.

18024

This label reminds you about the importance of reading and understanding the *Safety & Operating Instructions* manual and of paying attention to the safety warnings. #18836



Never detach a vacuum hose or remove a cover or guard while the engine is running. Unplug the spark plug wire first. #18886

## Protecting Yourself and Those Around You

---

### **WARNING!**

THIS IS A HIGH-POWERED MACHINE, WITH MOVING PARTS OPERATING WITH HIGH ENERGY AT HIGH SPEEDS. PROPER CLOTHING AND SAFETY GEAR MUST BE USED WHEN OPERATING THIS MACHINE TO PREVENT OR MINIMIZE THE RISK OF SEVERE INJURY. THIS MACHINE CAN CUT, AND SEVER PARTS OF YOUR BODY IF THEY BECOME IN CONTACT WITH THE CHIPPING BLADES. ALWAYS TAKE THE FOLLOWING PRECAUTIONS WHEN OPERATING THIS MACHINE:

- ALWAYS WEAR PROTECTIVE GOGGLES OR SAFETY GLASSES WITH SIDE SHIELDS WHILE OPERATING EITHER YOUR TRACTOR LAWN DECK, VACUUM SYSTEM, CHIPPER OR PERFORMING AN ADJUSTMENT ON YOUR DR LEAF AND LAWN VACUUM TO PROTECT YOUR EYES FROM POSSIBLE FOREIGN OBJECTS THROWN FROM THE MACHINE.
  - WEAR SHOES WITH NON-SLIP TREADS WHEN USING YOUR DR LEAF AND LAWN VACUUM. IF YOU HAVE SAFETY SHOES, WE RECOMMEND WEARING THEM. DO NOT USE THE MACHINE WHILE BAREFOOT OR WEARING OPEN SANDALS.
  - AVOID WEARING LOOSE CLOTHING OR JEWELRY, WHICH MIGHT BE CAUGHT ON THE MACHINE'S MOVING PARTS.
  - WE RECOMMEND WEARING GLOVES WHILE USING YOUR DR LEAF AND LAWN VACUUM. BE SURE YOUR GLOVES FIT PROPERLY AND DO NOT HAVE LOOSE CUFFS OR DRAWSTRINGS.
- 

## Operating the Vacuum Safely

---

### **WARNING!**

THIS IS A HIGH-POWERED MACHINE, WITH MOVING PARTS OPERATING WITH HIGH ENERGY AT HIGH SPEEDS. THE MACHINE MUST BE OPERATED SAFELY. UNSAFE OPERATION CAN CREATE A NUMBER OF HAZARDS FOR YOU, AS WELL AS ANYONE ELSE IN THE NEARBY AREA. ALWAYS TAKE THE FOLLOWING PRECAUTIONS WHEN USING THIS MACHINE:

- NEVER ALLOW PEOPLE WHO ARE UNFAMILIAR WITH THESE INSTRUCTIONS TO USE THE DR LEAF AND LAWN VACUUM.
- TO BE SAFE, DO NOT OPERATE THE MACHINE NEAR SMALL CHILDREN OR PETS, AND NEVER ALLOW CHILDREN TO OPERATE THE MOWER. STOP THE VACUUM ENGINE AND TRACTOR ENGINE WHEN ANOTHER PERSON OR PET APPROACHES.
- NEVER ALLOW PEOPLE OR PETS TO RIDE IN THE COLLECTOR BOX OR ON THE TRAILER.
- NEVER START THE BLOWER/CHIPPER ENGINE UNLESS IT IS BOLTED FIRMLY TO THE ENGINE MOUNTING PLATE AND THE MOUNTING PLATE IS ATTACHED FIRMLY TO THE TRAILER CHASSIS USING THE FOUR (4) RETAINING KNOBS. SEE *FIGURE 37*.
- CHECK BEHIND YOUR DR LEAF AND LAWN VACUUM BEFORE BACKING UP. YOU CANNOT SEE DIRECTLY BEHIND THE COLLECTOR BOX.
- NEVER ATTEMPT TO DUMP A LOAD WHILE THE LAWN TRACTOR ENGINE OR THE DR LEAF AND LAWN VACUUM ENGINE IS RUNNING.
- DO NOT VACUUM IN SANDY AREAS WHERE LARGE QUANTITIES OF SAND WILL BE VACUUMED WHILE MOWING OR VACUUMING. SAND WILL ERODE THE VACUUM HOUSING. CHECK FOR PIN HOLES AFTER EACH USE AND REPLACE THE HOUSING WHEN PIN HOLES DEVELOP.



---

**! WARNING!**

- DO NOT ATTEMPT TO OPEN THE COLLECTOR BOX WHEN YOUR DR LEAF AND LAWN VACUUM ENGINE OR YOUR LAWN DECK ENGINE IS OPERATING. DEBRIS MAY BE PROPELLED AT HIGH VELOCITY OUT OF THE SMALL OPENINGS CREATED IN THE SEAMS OF THE COLLECTOR BOX AS YOU UNLATCH THE COLLECTOR BOX PANELS.
  - NEVER OPERATE THE MACHINE ON SLOPES GREATER THAN 20°.
  - WHEN USING THE DR LEAF AND LAWN VACUUM AS A TRAILER, BE SURE TO SECURE THE LOAD.
  - NEVER TOW THE DR LEAF AND LAWN VACUUM FASTER THAN 8 MPH.
  - KEEP YOUR HANDS OUT OF THE CHIPPER HOPPER AND VACUUM INLET WHILE THE LAWN TRACTOR AND THE DR LEAF AND LAWN VACUUM ENGINES ARE RUNNING. IF IT BECOMES NECESSARY TO PUSH MATERIAL INTO THE HOPPER, USE A SMALL DIAMETER STICK.
  - ALWAYS SHUT OFF THE LAWN TRACTOR ENGINE AND THE DR LEAF AND LAWN VACUUM ENGINE, AND DISCONNECT THE SPARK PLUG WIRE BEFORE ATTEMPTING TO CLEAR ANY OBSTRUCTIONS IN THE HOSES OR CHIPPER HOPPER.
  - THE EXHAUST AREA ON THE ENGINE BECOMES VERY HOT WITH USE. ALLOW THE ENGINE TO COOL BEFORE DOING MAINTENANCE OR MAKING ADJUSTMENTS.
  - KEEP YOUR HANDS AND COMBUSTIBLE SUBSTANCES AWAY FROM THE ENGINE WHEN IT IS HOT AND CLEAN THE ENGINE AREA AFTER EACH USE.
  - USE THE DR LEAF AND LAWN VACUUM ONLY IN DAYLIGHT.
  - ALWAYS FEED THE CHIPPER FROM THE CHIPPING ZONE (*FIGURE 20*). NEVER STRADDLE OR REACH OVER THE ENGINE AREA AT ANY TIME.
  - USE ONLY YOUR HANDS TO OPERATE THE DR LEAF AND LAWN VACUUM ENGINE CONTROLS. ALWAYS DISMOUNT YOUR LAWN TRACTOR WHEN STARTING AND STOPPING THE DR LEAF AND LAWN VACUUM ENGINE TO PREVENT CONTACT WITH THE HOT MUFFLER.
  - DO NOT, UNDER ANY CONDITIONS, REMOVE, BEND, CUT, FIT, WELD, OR OTHERWISE ALTER STANDARD PARTS ON THE DR LEAF AND LAWN VACUUM. MODIFICATIONS TO YOUR MACHINE COULD CAUSE PERSONAL INJURIES AND WILL VOID YOUR WARRANTY.
  - DO NOT ALTER OR TAMPER WITH SAFETY DEVICES OR SHIELDS. MAKE SURE THEY ARE IN PROPER POSITION.
  - WHILE USING THE DR LEAF AND LAWN VACUUM, DON'T HURRY OR TAKE THINGS FOR GRANTED.
  - NEVER LEAVE THE DR LEAF AND LAWN VACUUM UNATTENDED WITH ITS MOTOR RUNNING.
  - DO NOT OPERATE THE MACHINE WHEN UNDER THE INFLUENCE OF ALCOHOL OR MEDICATION.
-

## *Slope Operation*

---

### **WARNING!**

SLOPES ARE A MAJOR FACTOR RELATED TO TIP OVER ACCIDENTS, WHICH CAN RESULT IN SEVERE INJURY. ALL SLOPES REQUIRE CAUTION. IF YOU FEEL UNEASY ON A SLOPE, DO NOT VACUUM IT. ALWAYS TAKE THE FOLLOWING PRECAUTIONS WHEN USING THIS MACHINE ON SLOPES:

#### **ALWAYS:**

- VACUUM UP AND DOWN THE FACE OF SLOPES; NEVER ACROSS. EXERCISE EXTREME CAUTION WHEN CHANGING DIRECTION ON SLOPES.
- REMOVE OBJECTS SUCH AS STONES, GLASS AND METAL OBJECTS SUCH AS CANS.
- WATCH FOR HOLES, RUTS, OR BUMPS. TALL GRASS CAN HIDE OBSTACLES.

#### **NEVER:**

- *NEVER* VACUUM NEAR DROP-OFFS, DITCHES, OR EMBANKMENTS. YOUR TRACTOR AND THE VACUUM MAY TIP OVER.
  - *NEVER* VACUUM ON SLOPES GREATER THAN 20 DEGREES OR ANY EXCESSIVELY STEEP SLOPES.
  - *NEVER* VACUUM ON WET SLOPES. REDUCED TRACTION COULD RESULT IN SLIPPING AND A POSSIBLE ROLL OVER.
- 

## *Safety for Children*

---

### **WARNING!**

TRAGIC ACCIDENTS CAN OCCUR IF THE OPERATOR IS NOT ALERT TO THE PRESENCE OF CHILDREN. CHILDREN ARE OFTEN ATTRACTED TO THE TRACTOR AND THE VACUUMING/CHIPPING ACTIVITY. *NEVER* ASSUME THAT CHILDREN WILL REMAIN WHERE YOU LAST SAW THEM.

- KEEP CHILDREN OUT OF THE WORK AREA AND UNDER THE WATCHFUL CARE OF A RESPONSIBLE ADULT.
  - BE ALERT AND ALWAYS TURN OFF THE LAWN TRACTOR ENGINE AND THE DR LEAF AND LAWN VACUUM ENGINE IF CHILDREN ENTER THE WORK AREA.
  - BEFORE AND WHILE MOVING BACKWARDS, LOOK BEHIND AND *DOWN* FOR SMALL CHILDREN. YOU CANNOT SEE DIRECTLY BEHIND THE COLLECTOR BOX.
  - NEVER ALLOW CHILDREN TO OPERATE THE TRACTOR OR VACUUM.
  - NEVER ALLOW CHILDREN TO PLAY IN THE COLLECTOR BOX. IF THEY BECOME TRAPPED IN THE ENCLOSURE THEY MAY BE EXPOSED TO TEMPERATURES SIMILAR TO LEAVING A CHILD IN A CAR WITH THE WINDOWS CLOSED ON A SUNNY DAY.
  - USE EXTRA CARE WHEN APPROACHING BLIND CORNERS, SHRUBS, TREES, OR OTHER OBJECTS THAT MAY OBSCURE YOUR VISION.
-

## *Safety with Gasoline-Powered Machines*

---

**! WARNING!**

**GASOLINE IS A HIGHLY FLAMMABLE LIQUID. GASOLINE ALSO GIVES OFF FLAMMABLE VAPOR THAT CAN BE EASILY IGNITED AND CAUSE A FIRE OR EXPLOSION. NEVER OVERLOOK THE HAZARDS OF GASOLINE. ALWAYS FOLLOW THESE PRECAUTIONS:**

- **NEVER RUN THE ENGINE IN AN ENCLOSED AREA OR WITHOUT PROPER VENTILATION AS THE EXHAUST FROM THE ENGINE CONTAINS CARBON MONOXIDE, WHICH IS AN ODORLESS, TASTELESS, AND DEADLY POISONOUS GAS.**
  - **STORE ALL FUEL AND OIL IN CONTAINERS SPECIFICALLY DESIGNED AND APPROVED FOR THIS PURPOSE AND KEEP AWAY FROM HEAT AND OPEN FLAME, AND OUT OF THE REACH OF CHILDREN.**
  - **FILL THE GASOLINE TANK OUTDOORS WITH THE ENGINE OFF AND ALLOW THE ENGINE TO COOL COMPLETELY. DON'T HANDLE GASOLINE IF YOU OR ANYONE NEARBY IS SMOKING, OR IF YOU'RE NEAR ANYTHING THAT COULD CAUSE IT TO IGNITE OR EXPLODE. REPLACE THE FUEL TANK AND FUEL CONTAINER CAPS SECURELY.**
  - **IF YOU SPILL GASOLINE, DO NOT ATTEMPT TO START THE ENGINE. MOVE THE MACHINE AWAY FROM THE AREA OF THE SPILL AND AVOID CREATING ANY SOURCE OF IGNITION UNTIL THE GAS VAPORS HAVE DISSIPATED. WIPE UP ANY SPILLED FUEL TO PREVENT A FIRE HAZARD AND PROPERLY DISPOSE OF THE WASTE.**
  - **ALLOW THE ENGINE TO COOL COMPLETELY AND EMPTY THE COLLECTOR BOX BEFORE STORING THE DR LEAF AND LAWN VACUUM IN ANY ENCLOSURE. REMEMBER, DECOMPOSING MATERIAL CAN GENERATE HEAT AND START A FIRE. NEVER STORE THE MACHINE WITH GAS IN THE TANK OR A FUEL CONTAINER, NEAR AN OPEN FLAME OR SPARK SUCH AS A WATER HEATER.**
  - **NEVER MAKE ADJUSTMENTS OR REPAIRS WITH THE ENGINE RUNNING. DISCONNECT THE SPARK PLUG WIRE AND KEEP THE WIRE AWAY FROM THE SPARK PLUG TO PREVENT ACCIDENTAL STARTING.**
  - **NEVER TAMPER WITH SAFETY DEVICES. CHECK THEIR PROPER OPERATION REGULARLY.**
  - **DO NOT CHANGE THE ENGINE GOVERNOR SETTINGS OR MODIFY THE ENGINE SPEED. MODIFICATIONS WILL VOID YOUR WARRANTY.**
  - **TO REDUCE FIRE HAZARD, KEEP THE ENGINE COOLING FAN AND MUFFLER AREA FREE OF DEBRIS BUILD-UP SUCH AS LEAVES, GRASS, OIL, GREASE OR ANY OTHER COMBUSTIBLE MATERIAL.**
  - **DO NOT OPERATE THE ENGINE IF THE AIR CLEANER OR THE COVER OVER THE CARBURETOR AIR-INTAKE IS REMOVED, EXCEPT FOR ADJUSTMENT. REMOVAL OF SUCH PARTS COULD CREATE A FIRE HAZARD.**
-

---

**! CAUTION!**

THE DR LEAF AND LAWN VACUUM MUST BE OPERATED SAFELY TO PREVENT OR MINIMIZE THE RISK OF MINOR OR MODERATE INJURY. UNSAFE OPERATION CAN CREATE A NUMBER OF HAZARDS FOR YOU. ALWAYS TAKE THE FOLLOWING PRECAUTIONS WHEN OPERATING THIS MACHINE:

- KEEP IN MIND THAT THE OPERATOR OR USER IS RESPONSIBLE FOR ACCIDENTS OR HAZARDS OCCURRING TO OTHER PEOPLE, THEIR PROPERTY, AND THEMSELVES.
  - USE EAR PROTECTION OR EAR PLUGS RATED FOR AT LEAST 20 DBA TO PROTECT YOUR HEARING.
  - WEAR LONG PANTS WHILE VACUUMING OR CHIPPING.
  - REMOVE SIDE BRANCHES BEFORE CHIPPING TO PREVENT JAMMING THE MATERIAL IN THE CHIPPER HOPPER.
  - DO NOT ATTEMPT TO CHIP WOOD LARGER THAN SPECIFIED IN THIS MANUAL.
  - NEVER USE THE DR LEAF AND LAWN VACUUM TO VACUUM ANYTHING BUT YARD WASTE, SUCH AS LEAVES, GRASS, SMALL TWIGS AND PINE CONES.
  - IF THE MACHINE STARTS TO MAKE AN UNUSUAL NOISE OR VIBRATION, IMMEDIATELY SHUT OFF THE ENGINE, DISCONNECT THE SPARK PLUG WIRE, AND ALLOW ALL MOVING PARTS TO COME TO A COMPLETE STOP. INSPECT FOR CLOGGING OR DAMAGE. CLEAN AND REPAIR AND/OR REPLACE DAMAGED PARTS.
  - SEE MANUFACTURER'S INSTRUCTIONS FOR PROPER OPERATION AND INSTALLATION OF ACCESSORIES. ONLY USE ACCESSORIES APPROVED BY COUNTRY HOME PRODUCTS, INC.
  - ALWAYS KEEP THE EQUIPMENT IN A GOOD SAFE OPERATING CONDITION. ALWAYS MAKE CERTAIN NUTS AND BOLTS ARE TIGHT AND ALWAYS USE THE SUPPLIED SELF-LOCKING HARDWARE; DO NOT SUBSTITUTE.
  - NO LIST OF WARNINGS AND CAUTIONS CAN BE ALL-INCLUSIVE. IF SITUATIONS OCCUR THAT ARE NOT COVERED BY THIS MANUAL, THE OPERATOR MUST APPLY COMMON SENSE AND OPERATE THE DR LEAF AND LAWN VACUUM IN A SAFE MANNER. CALL 1(800) DR-OWNER (376-9637) FOR ASSISTANCE.
- 

### *A Note to All Users*

Under California law, and the laws of some other states, you are not permitted to operate an internal combustion engine using hydrocarbon fuels without an engine spark arrester. This also applies to operation on US Forest Lands. All DR LEAF and LAWN VACUUMS shipped to California and Washington State are provided with spark arresters. Failure of the owner/operator to maintain this equipment in compliance with state regulations is a misdemeanor under California law and may be in violation of other state and/or federal regulations. Contact your local fire marshal or forest service for specific information in your area.

### *Additional Information and Potential Changes*

Country Home Products, Inc. reserves the right to discontinue, change, and improve its products at any time without notice or obligation to the purchaser. The descriptions and specifications contained in this manual were in effect at printing. Equipment described within this manual may be optional. Some illustrations may not be applicable to your machine.

## **SETTING UP YOUR DR LEAF AND LAWN VACUUM**

This chapter outlines a few simple steps you will need to follow to set up your new machine before you use it. It may be helpful to familiarize yourself with the controls and features on your new machine by reviewing the picture in the next section before beginning the steps outlined in this chapter. **If you have any questions at all, please feel free to contact our Customer Service Representatives at our toll free number: 1-800-DR-OWNER (376-9637).**

# DR LEAF and LAWN VACUUM Controls and Features

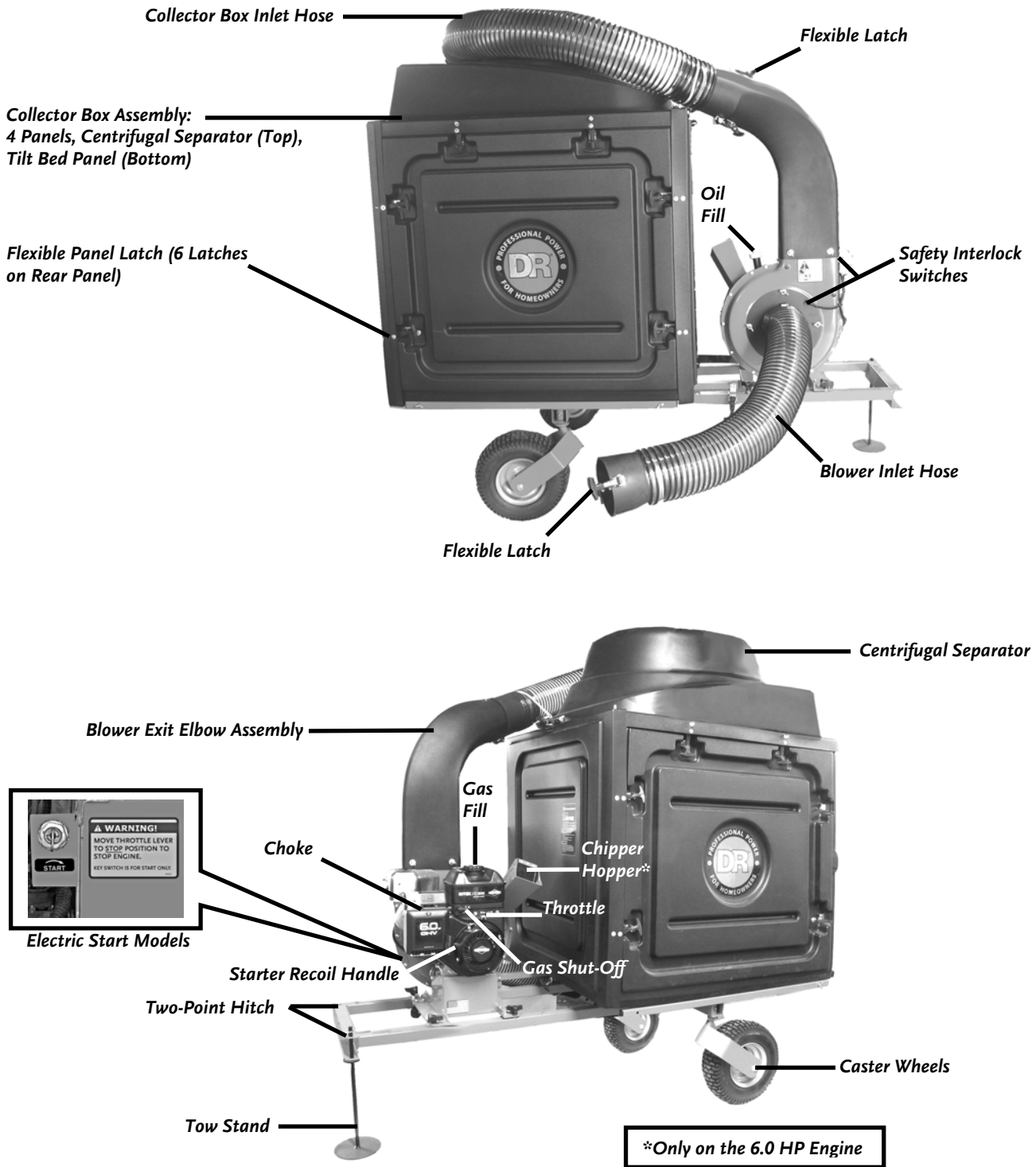

Figure 1

## ***Unpacking and Assembling the Machine***

The DR LEAF and LAWN VACUUM is shipped from the factory with the wheels mounted in the frame by spindle axles. The following instructions will detail how to unpack the machine, install the Tilt Bed, and assemble the Collector Box.

### **Tools & Supplies Needed:**

- Knife
- Gloves
- Eye protection
- Metal shears

### **Parts supplied:**

- (2) Side Collector Box Panels
- (1) Front Collector Box Panel
- (1) Rear Collector Box Panel
- (1) Centrifugal Separator with attached vacuum hose
- (1) Blower Outlet Hose Assembly
- (1) Trailer Frame
- (1) Tilt Bed
- (1) each 7" and 8" Hose Adapter
- Hearing Protectors
- (1) Plastic Bag containing miscellaneous mounting hardware:
  - (4) 5/16" x 1/2" Wing Screws
  - (4) 5/16" x 2" Wing Screws
  - (4) 5/16" x 1" Bolts
  - (16) 5/16" Flat Washers
  - (4) 5/16" Lock Nuts
  - (8) 5/16" Split Lock Washers
  - (4) Clevis Pins
  - (4) Hitch Clips
  - (2) Rubber Washers
  - (1) White Plastic Cable Tie
  - (2) Hand Knobs
  - (1) Tow Stand

## Attaching Hardware Description



5/16" WING NUT

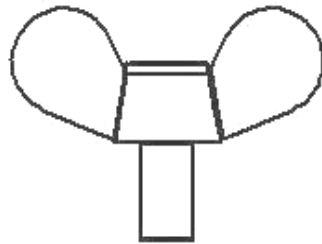

5/16" X 1/2" WING SCREW

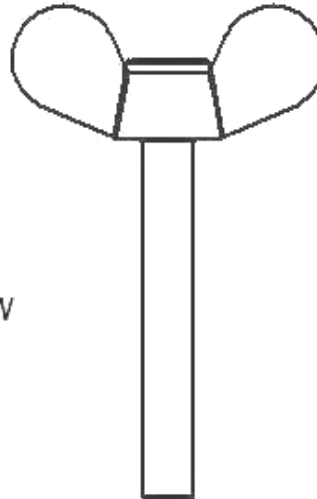

5/16 X 2" WING SCREW



RUBBER  
WASHER



5/16" X 1" BOLT



5/16" FLAT WASHER



5/16" LOCK NUT



5/16" LOCK WASHER



CLEVIS PIN



HITCH CLIP



## Opening the Shipping Container

### **! WARNING!**

- STABILIZE THE SHIPPING CONTAINER ON FLAT TERRAIN BEFORE ATTEMPTING TO UNPACK AND ASSEMBLE THE MACHINE.
- WEAR EYE PROTECTION WHEN CUTTING THE BANDS. THE BANDING MAY HAVE A LOT OF TENSION ON IT AND MAY SNAP AND CUT YOU. ALWAYS STAND TO ONE SIDE WHEN CUTTING THE BANDS.

#### Tools & Supplies Needed:

- Knife
- Gloves
- Eye Protection
- Metal Shears

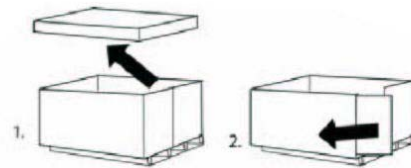

Opening the Carton

1. Stand to one side and cut the banding.
2. Remove the top of the carton, open the side the Centrifugal Separator is on and fold the side down (**Figure 2**). The staples are sharp so be careful.
3. Remove the Blower Exit Elbow Assembly from the cardboard (**Figure 2**) and set it aside.

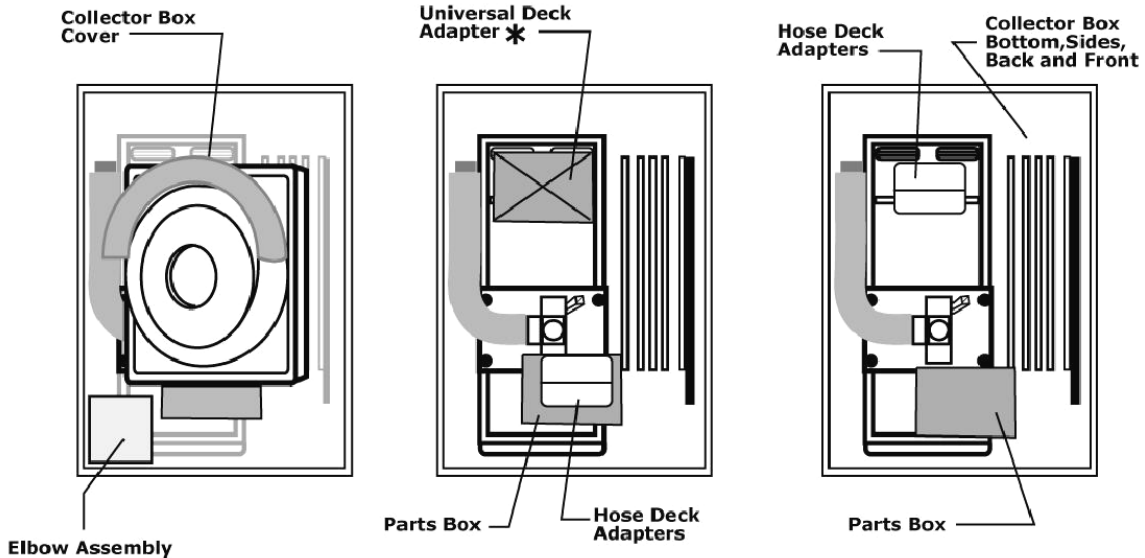
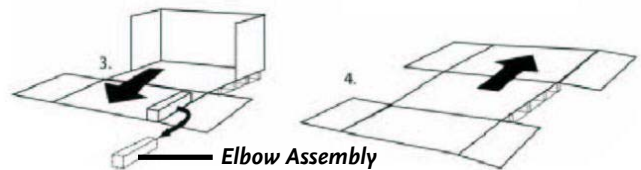

Figure 2

4. Remove the Collector Box Cover.
5. Open half of the opposite side of the carton, being sure to fold down only one half of the side.
6. Remove the Side, Bottom, Front & Rear Panels, and the Tilt Bed from the carton.
7. Remove the Adapter and Parts Boxes.
8. Locate the Hitch Kit (if provided) and the plastic bag containing the assembly hardware inside the small parts package.

**! WARNING!**

**WEAR EYE PROTECTION WHEN CUTTING THE BANDS. THE BANDING MAY HAVE A LOT OF TENSION ON IT AND MAY SNAP AND CUT YOU. ALWAYS STAND TO ONE SIDE WHEN CUTTING THE BANDS.**

- 9. Stand to one side and cut the pallet strapping holding the machine to the pallet.
- 10. Cut the wire ties and reposition the engine blower assembly on the trailer frame (Figure 2). Reinstall with four (4) sets of Hand Knobs, Washers and Lock Washers. Two (2) sets are in the plastic parts bag and two (2) sets held the engine in the shipping position.

**Tip:** Two people can move the engine mount easily.

- 11. Straighten the wheels, lift the tongue of the trailer and roll the machine from the shipping pallet.

**Tip:** An extra person would be helpful to guide the machine when rolling it from the shipping pallet using the “wheelbarrow” method. See below.

- 12. Save your pallet and packaging material until you are fully satisfied with your machine.

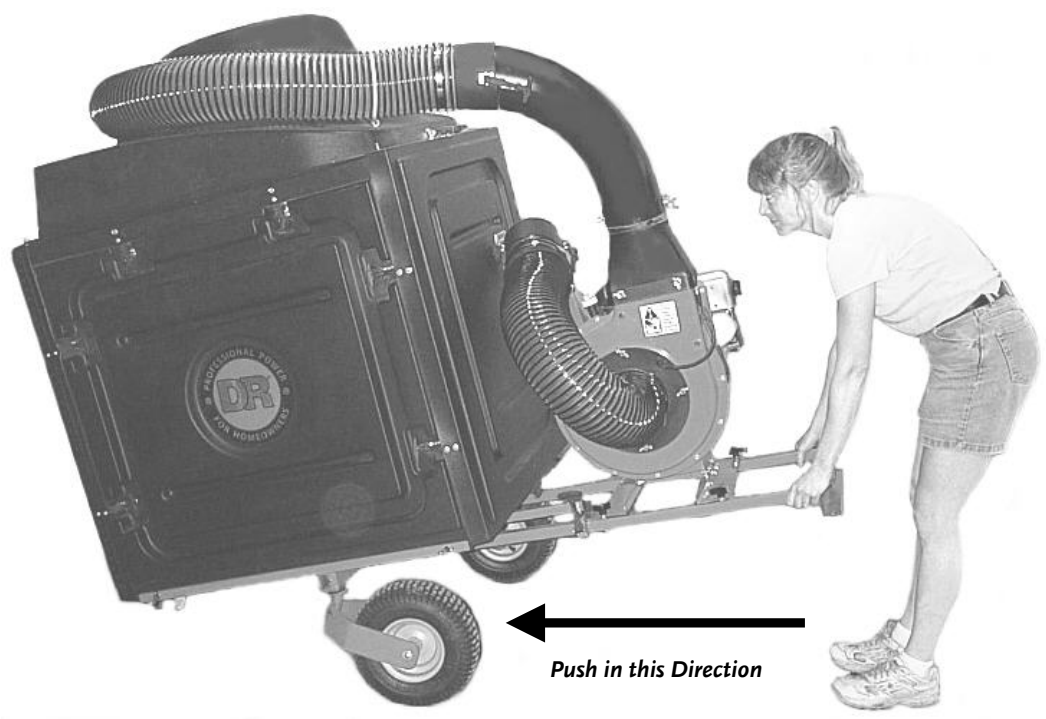

***Tire Pressure Check***

There should be 40 psi in each tire.

## Tilt Bed Installation

The following procedure includes all of the steps necessary for the installation of the Tilt Bed on the DR LEAF and LAWN VACUUM.

**NOTE:** The plastic Tilt Bed is mounted loosely on the frame to allow for expansion of the plastic.

1. Place the Tilt Bed on the trailer frame with the mating hinges at the same end.

**Tip:** Block the wheels to keep the machine from rolling away.

2. Align the left hinge on the Tilt Bed with the left hinge on the trailer frame (**Figure 3**).

3. Insert a Clevis Pin through the mated hinges and secure with a Hitch Clip (**Figure 3**).

**Tip:** Tilt the bed back for ease of inserting the Clevis Pins.

4. Repeat Step 3 for the right side hinges.

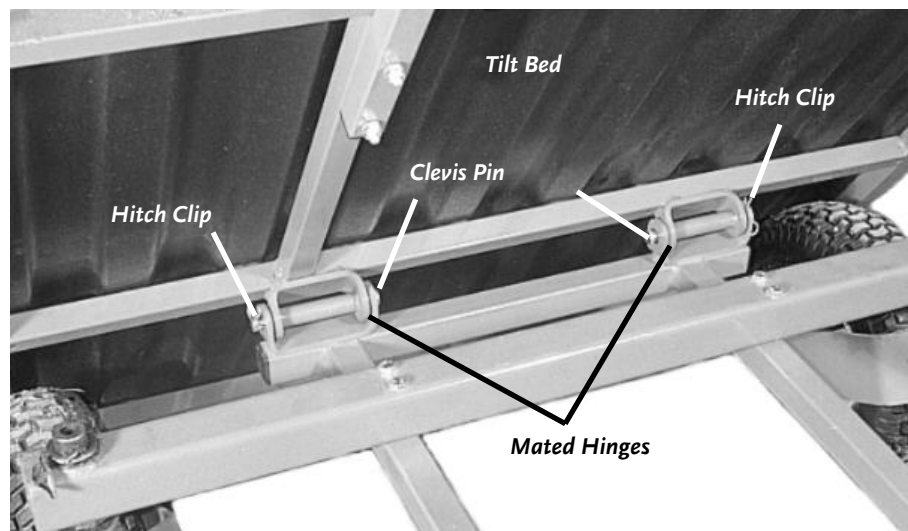

**Figure 3**

5. Secure the Tilt Bed in the down position before proceeding with the Collector Box installation by hooking the flexible Dump Latch into place (**Figure 4**).

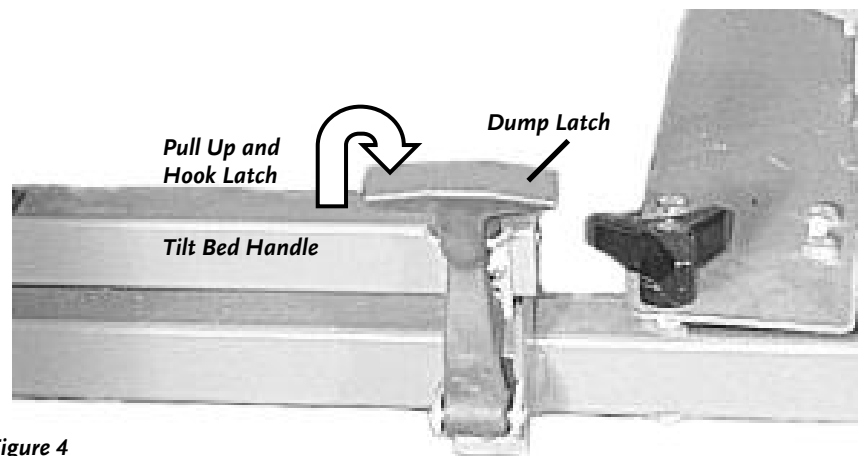

**Figure 4**

## Collector Box Installation

The following procedure includes all of the steps necessary for the installation of the Collector Box on the DR LEAF and LAWN VACUUM.

1. Place the projecting edges of the two (2) Side Panels on top of the Trailer with the Side Support Plates in the slots on the trailer as shown.

**NOTE:** The Side Support plates are loosely mounted to the Side Panels to allow for easy alignment and expansion of the plastic. Align the holes in the projecting edges with the holes in the trailer frame. Secure them at each end to the trailer frame with the 5/16" x 2" Wing Screws. Install a Lock Washer followed by a Flat Washer on each Wing Screw. The Wing Screws are inserted through the frame from the outside (**Figure 5**).

2. Tip the Centrifugal Separator at a 45° angle and slide it between the secured sides on the trailer with the hose protruding along the right side of the trailer pointing toward the front (**Figure 6**).
3. Place the left edge of the Centrifugal Separator on top of the left side panel. (**Figure 6**).

**Tip:** This can be accomplished easier with two (2) people.

4. Lift the hose side of the Centrifugal Separator and place it on top of the right side panel; align the holes in the top edges of the side panels with the protruding pins from the Centrifugal Separator and secure in place with the flexible latches (**Figure 7**).

**Tip:** Push out in the middle of the top of the side panel to help seat the pin in the hole in the middle of the top edge of the side panel

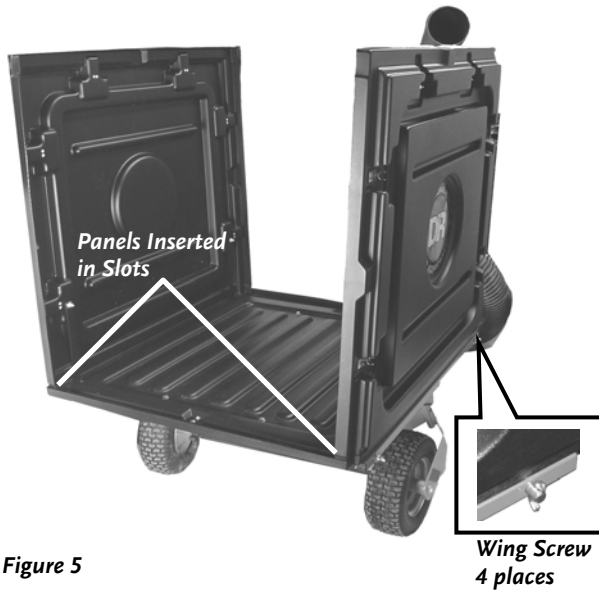

Figure 5



Figure 6

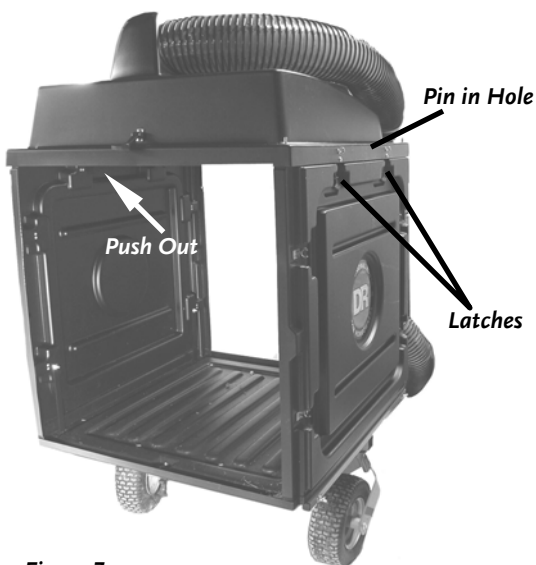

Figure 7

- Attach the front enclosure panel on the protruding support pins and fasten the sides, top and bottom using the six (6) flexible latches (**Figure 8**). Note the difference between the front and rear panels. The rear panel has the metal edge supports. The mounting holes are located on top of the panels.

**Tip:** For ease of attaching the front cover, release the Dump Latch and tilt the body back. Set the front panel over the protruding pins, one side at a time, making certain that the six (6) flexible latches are on the outside of the panels (**Figure 8**).

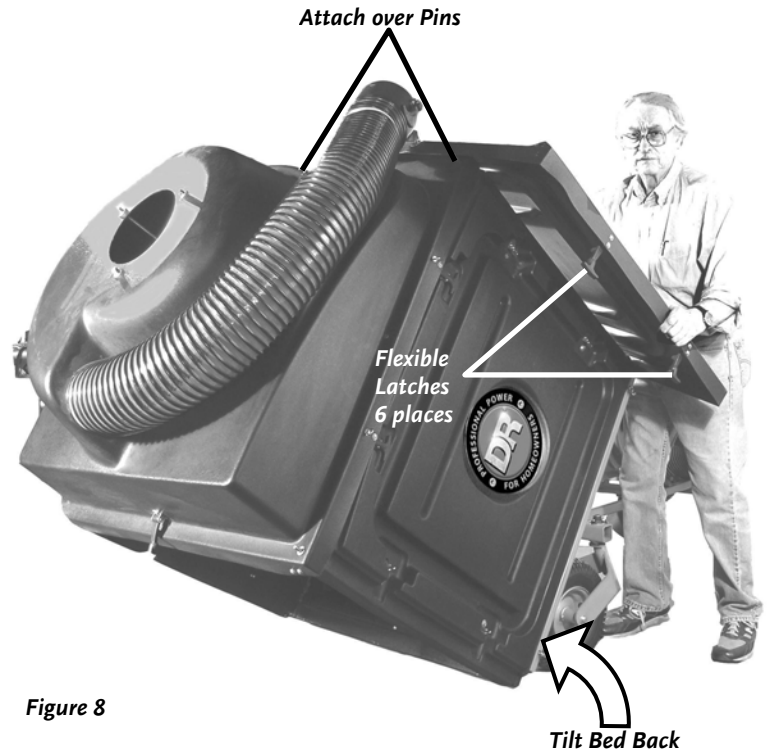

Figure 8

- Lower the bed and secure in place with the Dump Latch (**Figure 4** on page 14). Attach the rear panel on the protruding pins and secure in place with the six (6) flexible latches (**Figure 9**).

**Tip:** Set the rear panel over the protruding pins, one side at a time, making sure to keep the flexible latches on the outside of the box.

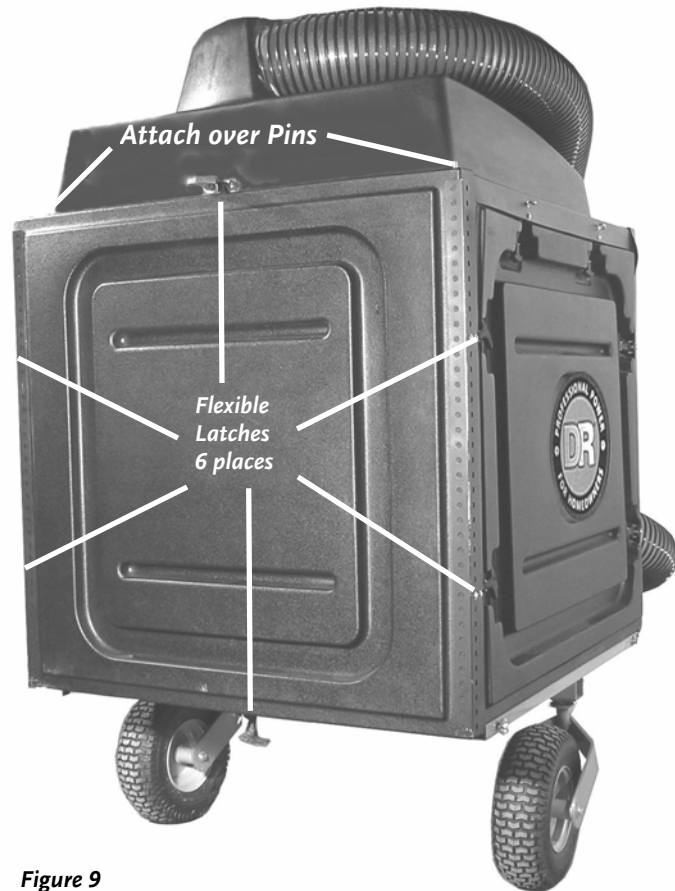

Figure 9

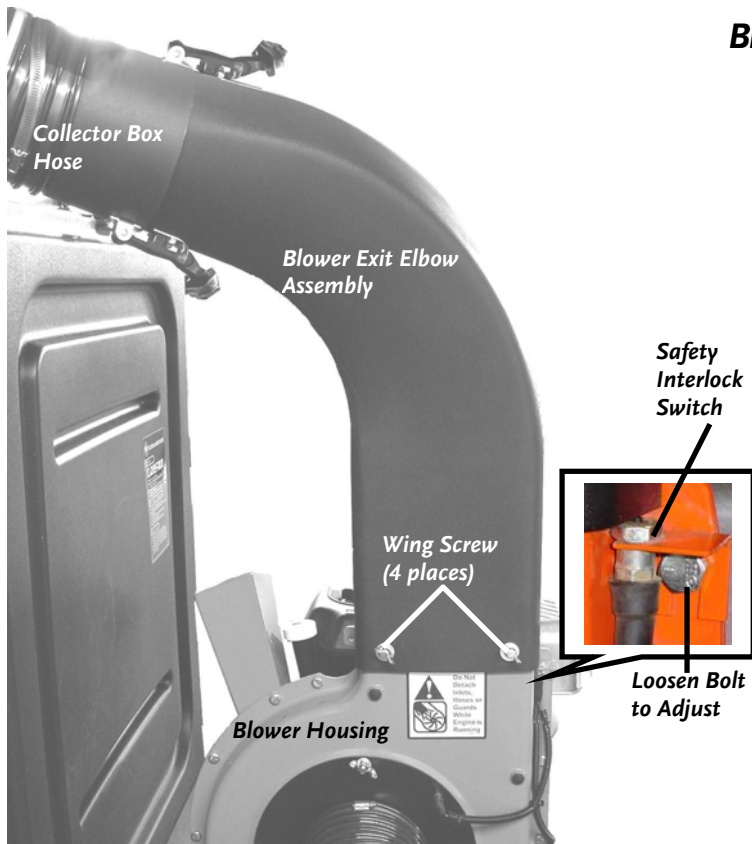

Figure 10

## Blower Exit Elbow Assembly Installation

The following procedure includes the steps necessary for installing the Blower Exit Elbow Assembly on the DR LEAF and LAWN VACUUM.

1. Install the Blower Exit Elbow Assembly on top of the Blower with the elbow pointing toward the Collector Box (**Figure 10**).
2. Align the hood of the Blower Exit Elbow Assembly to ensure that the Safety Interlock Switch is engaged, and then install a Lock Washer and Flat Washer over each of the four (4) 5/16" x 1/2" Wing Screws and hand tighten them to the Blower Housing (**Figure 10**).

**Tip:** Start all four (4) Wing Screws before tightening them securely.

**NOTE:** If the Safety Interlock Switch is not engaged, the engine will not start. Adjust the Switch Mounting Bracket by loosening the Bracket Bolt and sliding the Bracket up so that the button on the Switch is fully depressed against the Blower Exit Elbow Assembly.

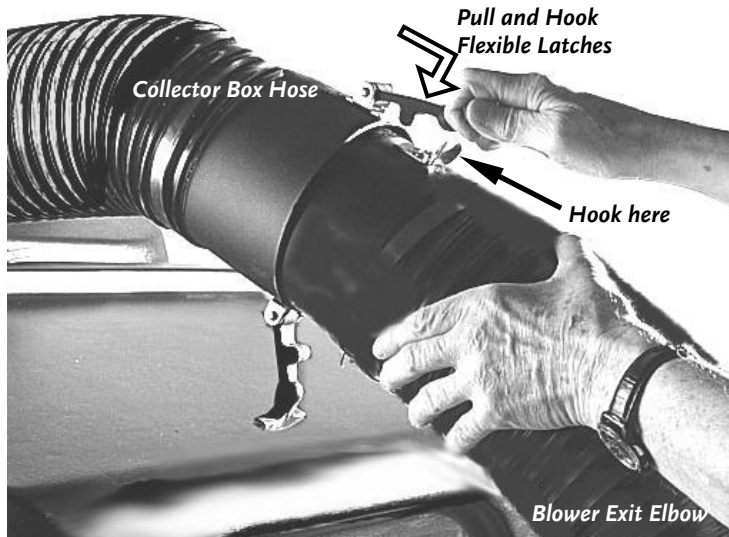

Figure 11

## Connecting the Collector Box Inlet Hose to the Blower Exit Elbow Assembly

The following procedure includes the steps necessary for connecting the Collector Box Inlet Hose to the Blower Exit Elbow Assembly on the DR LEAF and LAWN VACUUM.

1. Connect the hose from the Collector Box to the Blower Exit Elbow Assembly by aligning the two Flexible Latches (**Figure 11**) and slipping the hoses together.
2. Pull and hook the two Flexible Latches into place (**Figure 11**) to secure the hoses.

## Universal Hitch Plate Installation

**NOTE:** Depending on the size and shape of your lawn tractor, different Hitch Plate Kits may be used. Pick the configuration that aligns best with the existing mounting holes and avoids areas with other equipment such as the gas tank, battery or electrical wiring. You may need to drill mounting holes if none are available. A typical installation is shown in **Figure 12**.

### **! WARNING!**

IN DETERMINING WHICH HITCH PLATE CONFIGURATION TO USE, NOTE THE LOCATION OF THE BATTERY, FUEL TANK, ELECTRICAL WIRING, ETC. ON YOUR TRACTOR SO AS NOT TO DAMAGE THEM WITH THE MOUNTING HARDWARE. DETERMINE THE BEST ORIENTATION OF THE HITCH PLATE TO AVOID HITTING OTHER ITEMS WHILE DRILLING ANY HOLES.

Follow the mounting instructions provided with your Hitch Plate Kit. If you have difficulty attaching your Hitch Plate, please call **Toll-Free 1-800-DR-OWNER (376-9637)** and one of our Technical Support Representatives will be happy to help you.

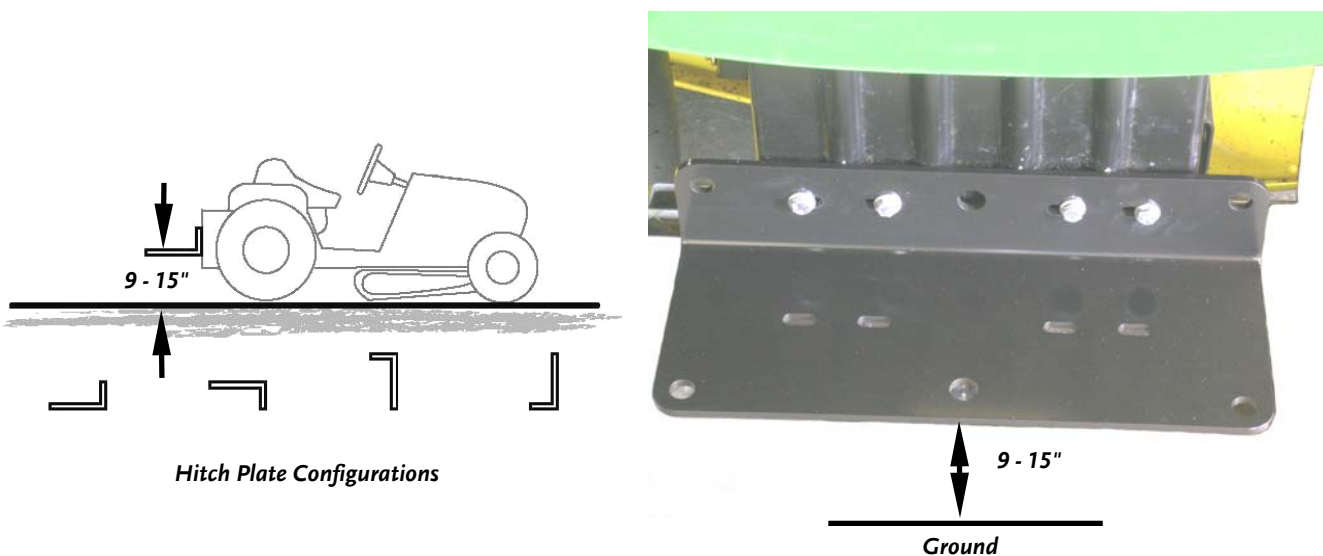

Typical Installation

Figure 12

### **! NOTICE!**

THE TOP SURFACE OF THE HITCH PLATE SHOULD BE 9 TO 15" FROM THE GROUND.

## Connecting the DR LEAF and LAWN VACUUM to your Lawn Tractor

The following procedure includes the steps necessary for connecting the DR LEAF and LAWN VACUUM to your lawn tractor.

1. Position your lawn tractor on level ground at a slight angle to the Two-Point Trailer Hitch on the DR LEAF and LAWN VACUUM (**Figure 13**) and set the parking brake.
2. Lift the Trailer Hitch and position one end of the Hitch so that the Hitch Plate is in the opening of the Trailer Hitch (**Figure 13**).
3. Align the closest hole in the Hitch Plate with the corresponding holes in the Trailer Hitch and insert a Clevis Pin w/Rubber Washer and Hitch Clip (**Figure 13**).
4. Pivot the Trailer around so that the Trailer Hitch moves in toward the Hitch Plate; aligning the remaining holes in the Hitch with outermost hole on the other end of the Hitch Plate (**Figure 13**).
5. Insert a second Clevis Pin and Hitch Clip.

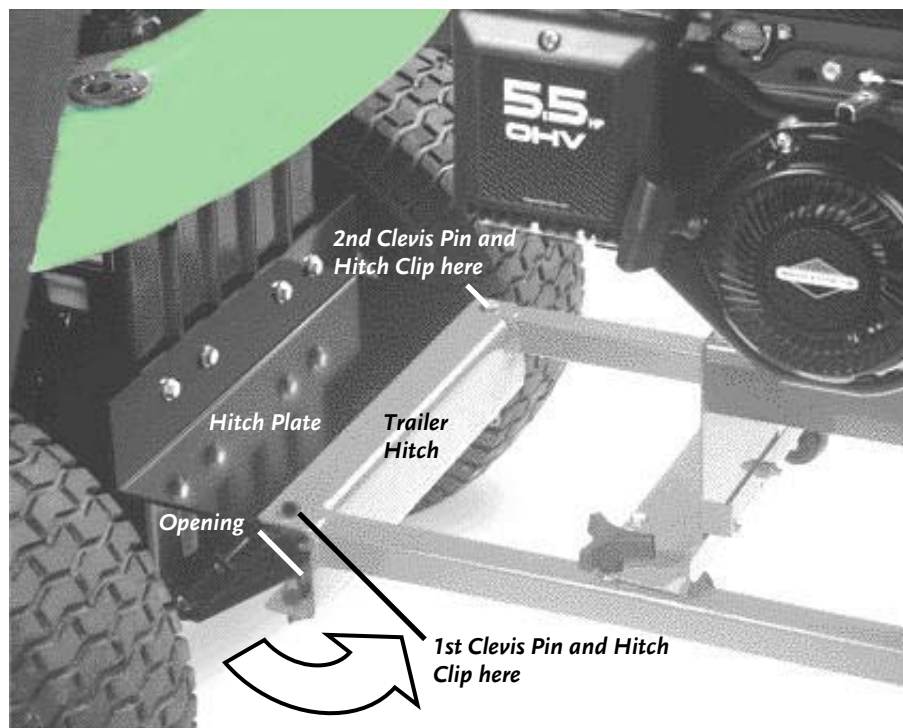

Figure 13



## Lawn Deck Adapter Installation

The following procedure includes the steps necessary for connecting the DR LEAF and LAWN VACUUM Blower Inlet Hose to your lawn tractor.

### Tools Needed:

- 1/2" Wrench or Socket
- Drill with 3/8" Bit
- Saw

1. Install your lawn deck adapter (available from the manufacturer of your lawn tractor) on your lawn tractor.

**NOTE:** *Optional Accessories – Due the variety of lawn tractors, the hose kits supplied may not fit all tractors. Our Technical Service Dept. can help you adapt to your machine.*

- *A Universal Deck Adapter is available for you to fit to your machine if the tractor manufacturer's lawn deck adapter is not available.*
  - *A Lawn Deck Adapter Extension is available to attach to a small deck adapter and support the vacuum hose.*
2. Mark the distance of approximately 23" from the ground to the top surface of your lawn deck adapter exit tube (**Figure 14**).
  3. Remove the lawn deck adapter from your lawn tractor and using a saw, cut the exit tube of the lawn deck adapter at 90° (**Figure 14**).

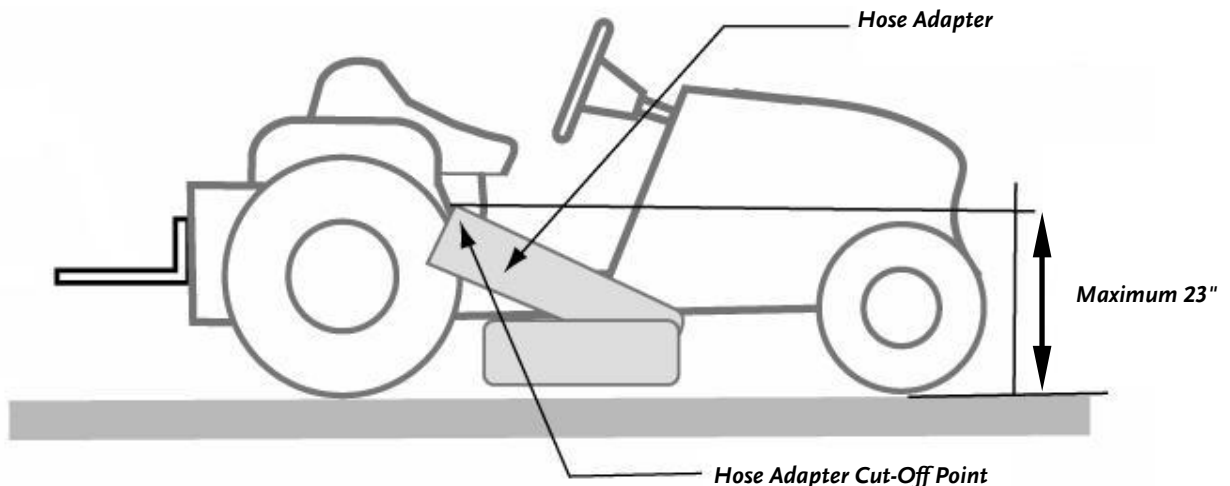

Figure 14

1. We have supplied both a 7" to 6" and 8" to 6" Hose Adapter. Determine which best fits your lawn deck adapter.
2. Slip the Hose Adapter over the cut end of your Lawn Deck Adapter, until they make contact.
3. Position the assembly beside your tractor and rotate Hose Adapter so that the hose latches will be located with one on top and one on the bottom of the Adapter (**Figure 15**).
4. Drill a 3/8" hole through the Hose Adapter and Lawn Deck Adapter tube at a predrilled hole in the Hose Adapter (**Figure 15**) and secure the Adapter in place with a 5/16" Bolt, Nut and Washer by inserting the bolt through the drilled hole from the inside the Adapter tube.
5. Attach the washer and nut on the outside of the Adapter tube, thus preventing debris from collecting on the retaining hardware (**Figure 15**).
6. Repeat Steps 7 & 8 two more times as shown around the Hose Adapter (**Figure 15**).

**NOTE:** Two holes are provided in the Hose Adapter as guides. The third hole should be drilled on top of the Hose Adapter for ease of assembly.

7. Tighten the nuts with a 1/2" wrench or socket. Be careful not to over tighten and damage the Hose Adapter.
8. Re-install the lawn deck adapter.



**Figure 15**

## Connecting the Blower Inlet Vacuum Hose to the Hose Adapter

The following procedure includes the steps necessary for connecting the Blower Inlet Vacuum Hose of the DR LEAF and LAWN VACUUM to the Hose Adapter.

### Tools May Be Needed:

- Wire Cutters or Hack Saw
- Knife
- Screw driver or Nut driver

1. Connect the hose from the Blower Inlet to the Hose Adapter by aligning the two flexible latches and slipping the end of the hose over the Hose Adapter (**Figure 16**).
2. Pull and hook the two flexible latches into place (**Figure 16**) to secure the hose.

**Tip:** If the latches do not align, loosen the hose clamp on the Inlet Hose and rotate the hose connector into alignment.

**Tip:** If there is excess hose, reduce the length of the hose by removing the hose clamp on the end of the hose with a screw driver, and cut the hose to length required using wire cutters to cut the spiral and then cut the hose between the spirals with the knife. Then reinstall hose and hose clamp.

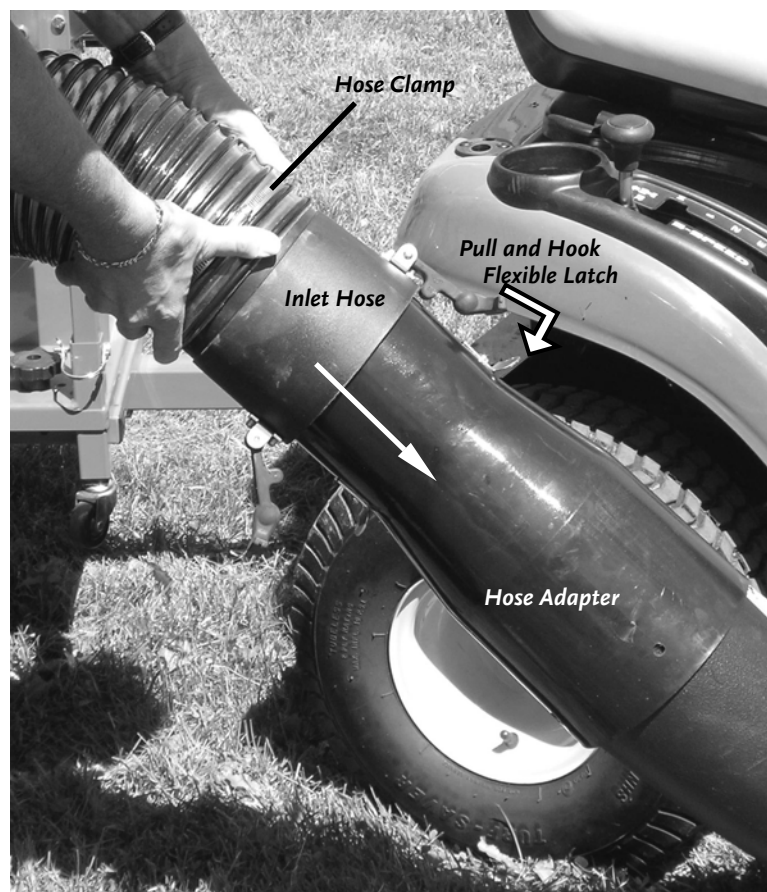

Figure 16

## Connecting the Battery Wire (Electric-Starting Models Only)

We ship all electric-starting systems with the negative terminal battery wire disconnected. This prevents the battery from discharging during shipment. Before using your DR LEAF and LAWN VACUUM, you must connect the battery wire.

### Tools Needed:

- (2) 5/16" wrenches or sockets

Connect the negative wire to the negative terminal on the battery (**Figure 17**).

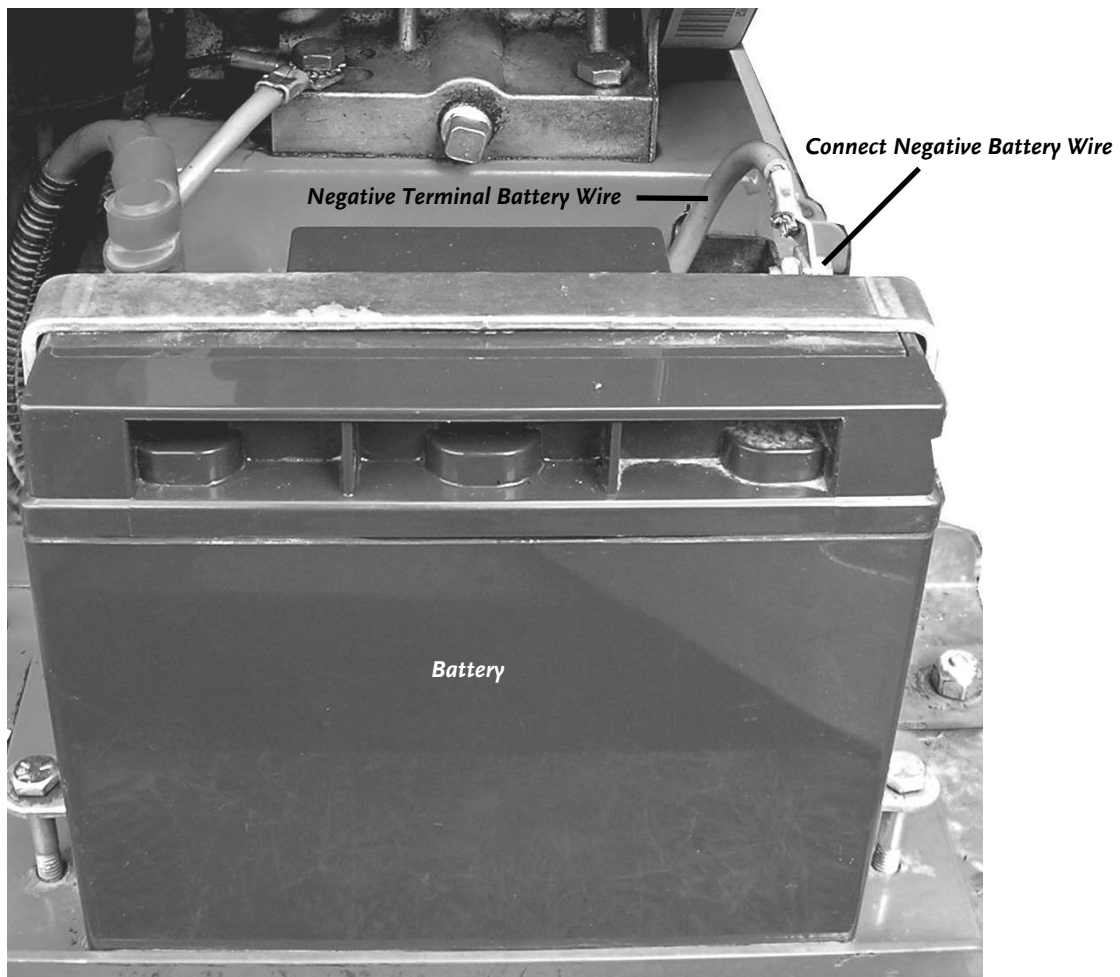

Figure 17

## Adding the Engine Oil and Gasoline

### **! NOTICE!**

- **YOU MUST ADD OIL BEFORE STARTING THE ENGINE. THIS MACHINE IS SHIPPED WITHOUT OIL. TRACES OF OIL MAY BE IN THE RESERVOIR FROM FACTORY TESTING, BUT YOU MUST ADD OIL BEFORE STARTING THE ENGINE. FILL THE RESERVOIR SLOWLY CHECKING THE DIPSTICK FREQUENTLY TO AVOID OVERFILLING.**
- **TO GET AN ACCURATE READING WHEN CHECKING THE OIL LEVEL:**
  - ⇒ **THE MACHINE SHOULD BE ON A LEVEL SURFACE.**
  - ⇒ **THE DIPSTICK SHOULD BE SCREWED DOWN ON BRIGGS & STRATTON ENGINES.**

Capacities	
Briggs & Stratton 6.0 HP Intek Engine	SAE 30 – 20 oz. (.60L)
Briggs & Stratton 5.5 HP Intek Engine	SAE 30 – 20 oz. (.60L)
Gasoline Tank	Unleaded gasoline, .53 US gal. (2 L)

**Tip:** To avoid confusion, we recommend leaving the caps on the fuel and engine oil fills and only removing one cap each time when you are ready to pour gasoline or oil into the correct fill.

**NOTE:** Use only SAE 30 high detergent oil. Other types of oil could cause problems operating your machine. Please refer to your engine owner manual for detailed oil information.

1. Place the machine on a level surface and initially add 16 oz. ( $\frac{1}{2}$  quart) of SAE 30 oil, recommended by the engine manufacturer, and wait one minute for the oil to settle (**Figure 18**).
2. Check the dipstick and continue adding a few ounces of oil at a time, rechecking the dipstick until the oil reaches the fill mark. Be careful not to overfill (**Figure 18**).
3. Fill the gas tank to within 1- $\frac{1}{2}$  inch below top of fill neck (to allow for fuel expansion) with fresh, unleaded gas. See your engine manufacturer's owner's manual for more information.

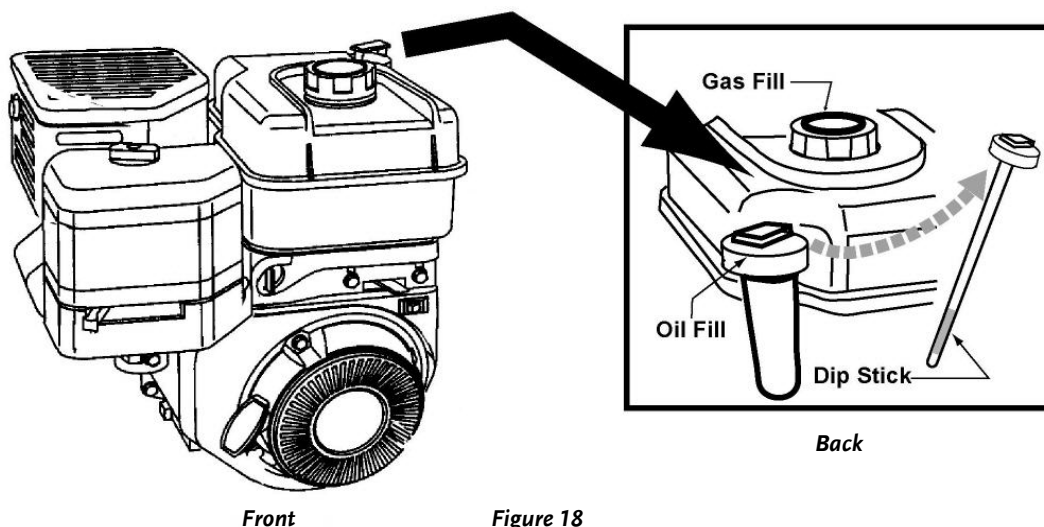

Figure 18

## OPERATING YOUR DR LEAF AND LAWN VACUUM

This chapter covers the procedures for starting and stopping your new DR LEAF and LAWN VACUUM and also discusses basic operation features.

### Before Starting the Engine

#### **! WARNING!**

INSPECT THE AREA IN WHICH YOU WILL BE WORKING. THE SITE MUST BE FREE OF POTENTIALLY HAZARDOUS OBSTACLES SUCH AS STONES, METAL OR GLASS. PILE STICKS THAT YOU INTEND TO CHIP SEPARATELY AND AWAY FROM THE VACUUM SITE. ALSO MAKE SURE THERE WON'T BE PEOPLE OR ANIMALS IN THE AREA AROUND THE DR LEAF AND LAWN VACUUM.

1. Connect the DR LEAF and LAWN VACUUM to your lawn tractor (see page 20).
2. Check the engine oil level every time you use the machine (see **Figure 18** on page 25).
3. Check the gasoline level (see **Figure 18**).
4. Turn the Gas Shut-Off valve to the OPEN position (**Figure 19**).

### Starting and Stopping

1. When starting a cold engine; push the Choke Control lever to the right (CHOKE) and the Throttle Control lever to the far right (**Figure 19**).
2. **Manual Start** - Grasp the recoil starter handle and slowly pull until you feel resistance, then pull the cord with a smooth accelerating motion to start the engine. One or two pulls usually starts the DR LEAF and LAWN VACUUM.  
**Electric Start** - Turn the Key to START until the engine starts and then release. The Key will snap back when released and the engine will continue to run.
3. After the engine starts, slowly push the Choke Control lever to the left (RUN) position. Wait until the engine runs smoothly before each choke adjustment (**Figure 19**). For best engine performance, it is recommended that the engine be operated with the throttle in the fast (Rabbit) position (**Figure 19**).
4. **To stop the engine**, move the Throttle to the slow (Turtle) position allowing the engine to idle, then move the lever to STOP (Stop Sign) position (**Figure 19**).

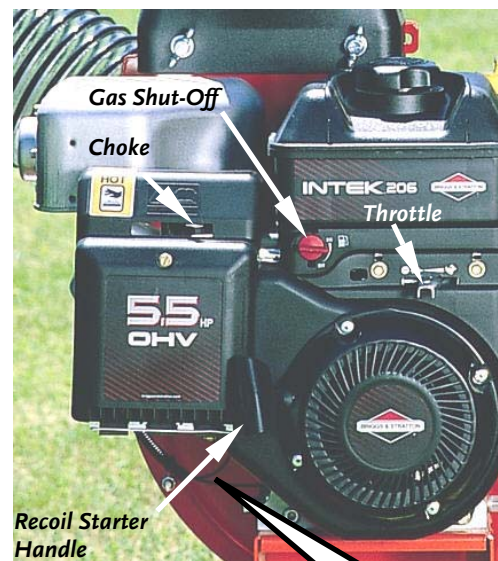

Figure 19



Electric Start Models

---

**! NOTICE!**

THE ENGINE WILL NOT START IF THE SAFETY INTERLOCK SWITCHES ARE NOT PROPERLY ADJUSTED. SEE PAGE 18 *FIGURE 10* AND PAGE 41 *FIGURE 35*.

---

**! WARNING!**

THE KEY WILL NOT TURN OFF THE ENGINE. THE THROTTLE MUST BE MOVED TO THE STOP POSITION.

---

### *Operating Safety*

The DR LEAF and LAWN VACUUM has a blower motor capable of 1650 CFM suction capacity and a chipper feature that will chip wood up to 2 inches in diameter.

5. **NOTE:** *Always* be sure to stand inside the **Operator Zones** to run the DR LEAF and LAWN VACUUM as a chipper or held hand vacuum. These are the areas on either side of your machine (**Figure 20**).

---

**! WARNING!**

- NEVER PUT YOUR HANDS INSIDE THE VACUUM HOSE OR THE CHIPPER HOPPER TO CLEAR DEBRIS WHILE THE ENGINE IS RUNNING. ALWAYS STOP THE ENGINE AND DISCONNECT THE SPARK PLUG WIRE BEFORE CLEARING THE VACUUM HOSE OR CHIPPER HOPPER.
  - FOR BEST RESULTS, USE A SMALL STICK TO CLEAR THE CHIPPER HOPPER IF IT BECOMES CLOGGED.
  - THE MAXIMUM SIZE MATERIAL THAT CAN BE FED INTO THE CHIPPER HOPPER IS 2 INCHES IN DIAMETER.
  - KEEP YOUR FACE AND BODY BACK FROM THE CHIPPER HOPPER OPENING TO PREVENT BEING STRUCK BY ANY MATERIAL THAT MAY BOUNCE BACK.
  - DO NOT REFUEL THE ENGINE WHILE IT IS HOT OR RUNNING.
- 

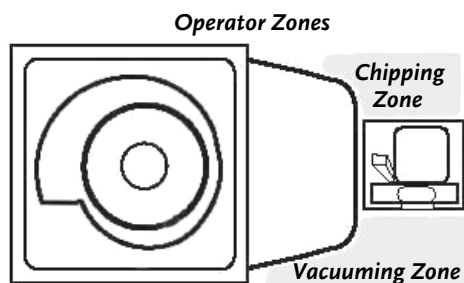

Figure 20

---

**! NOTICE!**

USE COMMON SENSE WHEN USING THE MACHINE. LEARN TO RECOGNIZE THE CHANGES IN SOUND WHEN IT IS OVERLOADED. STOP THE ENGINE IMMEDIATELY IF THE MACHINE BECOMES JAMMED TO PREVENT DAMAGE TO THE DRIVE SYSTEM.

---

## Towing the DR LEAF and LAWN VACUUM

1. Make sure the DR LEAF and LAWN VACUUM trailer hitch is firmly attached to your lawn tractor Hitch Plate using the Clevis Pins and Hitch Clips. See Connecting the DR LEAF and LAWN VACUUM to your Lawn Tractor on page 20.
2. Make sure the Collector Box tilt bed is secured down by the latch (**Figure 21**), and the Collector Box Inlet Hose is latched in place (**Figure 11** on page 18).
3. Make sure that the Blower Inlet Vacuum Hose is securely attached to the Hose Adapter (**Figure 16** on page 23).

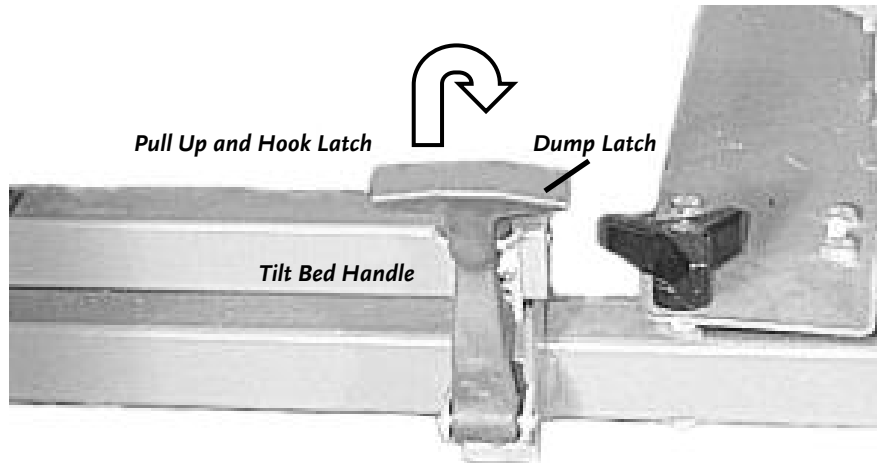

Figure 21

## Towing Safety

### **! WARNING!**

- NEVER ALLOW ANYONE TO RIDE IN OR ON THE DR LEAF AND LAWN VACUUM.
- WATCH OUT FOR LOW BRANCHES, OVERHANGS AND GUY WIRES THAT MAY CATCH ON TOP OF THE COLLECTOR BOX.
- OBEY LOCAL, STATE, AND FEDERAL REGULATIONS WHEN YOU TOW THE DR LEAF AND LAWN VACUUM ACROSS PUBLIC ROADS AND HIGHWAYS.
- USE CAUTION WHEN BACKING UP YOUR LAWN TRACTOR OR TRYING TO MAKE TIGHT TURNS GOING FORWARD WITH THE DR LEAF AND LAWN VACUUM ATTACHED. THE TRAILER WILL SWING QUICKLY AND SHARPLY SO ANTICIPATE YOUR TURNS, AND THE CLEARANCE REQUIRED.

### **! NOTICE!**

THE DR LEAF AND LAWN VACUUM TRAILER IS NOT EQUIPPED FOR HIGHWAY USE.



## Slopes and Uneven Terrain

### **! WARNING!**

- NEVER OPERATE YOUR MACHINE ON SLOPES GREATER THAN 20 DEGREES (*FIGURE 22*). DOING SO COULD RESULT IN SERIOUS INJURY OR DAMAGE TO YOUR MACHINE.
- WHEN OPERATING THE DR LEAF AND LAWN VACUUM OVER UNEVEN TERRAIN AND SLOPES, USE EXTREME CAUTION TO NOT TIP OVER THE MACHINE. MOVE SLOWLY, ESPECIALLY WITH A FULL LOAD, IF THE GROUND HAS RUTS, BUMPS AND OTHER DEPRESSIONS.
- ON A SLOPE, A HEAVY LOAD WILL TEND TO SHIFT. WHEN USING YOUR DR LEAF AND LAWN VACUUM, KEEP IN MIND THAT LOADS TEND TO SHIFT TO THE DOWNHILL SIDE OF THE COLLECTOR BOX. THE HIGHER AND HEAVIER THE LOAD, THE GREATER THE CHANCE THE MACHINE MAY TIP OVER.
- TRAVEL UP AND DOWN SLOPES (*FIGURE 22*) AND AVOID GOING ACROSS SLOPES. THIS IS THE SAME RECOMMENDATION FOR MOWING WITH YOUR LAWN TRACTOR ALONE.



*Figure 22*

## Operating the Chipper

In addition to towing the DR LEAF and LAWN VACUUM with your lawn tractor, and using it as a vacuum, the 6.0 HP system also allows you to chip sticks and limbs up to 2" in diameter.

### **! WARNING!**

- ALWAYS OPERATE THE CHIPPER FROM THE "CHIPPING ZONE" (SEE *FIGURE 20* ON PAGE 27).
- TO PREVENT DAMAGE TO YOUR CHIPPER, FEED ONLY WOOD UP TO 2" IN DIAMETER INTO THE CHIPPER HOPPER.
- BEFORE PERFORMING ANY MAINTENANCE PROCEDURE, STOP THE ENGINE AND DISCONNECT THE SPARK PLUG WIRE.
- NEVER USE YOUR HAND TO PUSH THE REMAINING WOOD STUB DOWN INTO THE CHIPPER HOPPER OR TRY TO REMOVE A LODGED PIECE OF WOOD WITH THE ENGINE RUNNING.

1. Start the engine in accordance with "Starting & Stopping" on page 26.
2. To process branches; feed them into the Chipper Hopper opening (*Figure 23*).
3. As the chipped branch shortens, finish chipping it by pushing the stub down the Hopper with the next branch to be chipped.

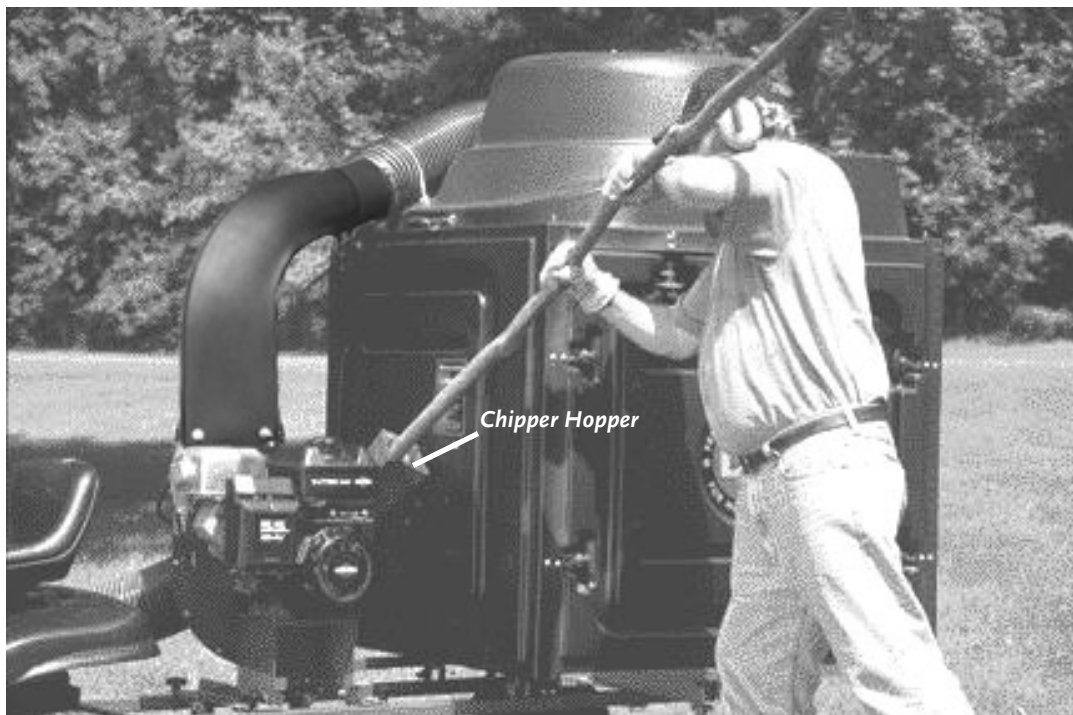

*Figure 23*

**Tips:**

- It is best to trim off any side twigs from the main branch being chipped (**Figure 24**).
- Green branches process quicker and easier than dry branches and soft wood is easier than hardwood.
- Use caution with small diameter green saplings and branches. Chip these grouped or bundled together to provide support for each other (**Figure 25**).
- Make sure the Chipper finishes chipping material in the Hopper before shutting the engine off.



**Figure 24**

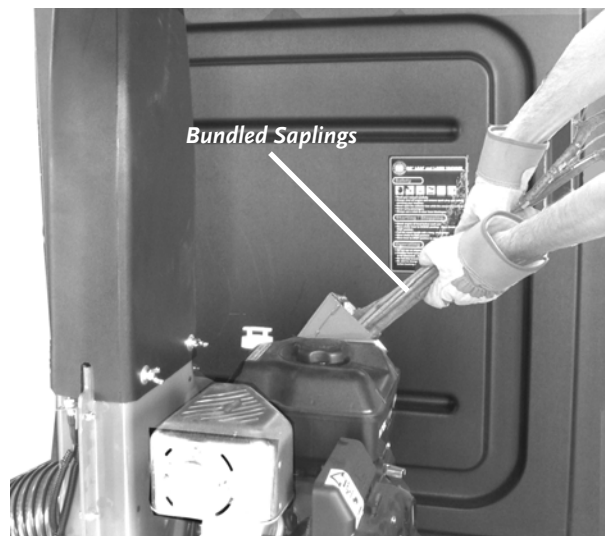

**Figure 25**

---

**! NOTICE!**

**USE COMMON SENSE WHEN USING THE MACHINE. LEARN TO RECOGNIZE THE CHANGE IN SOUNDS WHEN IT IS OVERLOADED. STOP THE ENGINE IMMEDIATELY IF THE MACHINE BECOMES JAMMED TO PREVENT DAMAGE TO THE DRIVE SYSTEM.**

---

## Dumping



Figure 26

### **! WARNING!**

- ALWAYS SHUT OFF THE TRACTOR ENGINE AND THE VACUUM ENGINE AND USE CAUTION WHEN DUMPING THE COLLECTOR BOX LOAD.
- THE LOAD MAY HAVE SHIFTED AGAINST THE REAR PANEL. PUSH DOWN ON THE TILT BED FRAME WHEN RELEASING THE DUMP LATCH TO PREVENT THE TILT BED FROM SUDDENLY TIPPING.

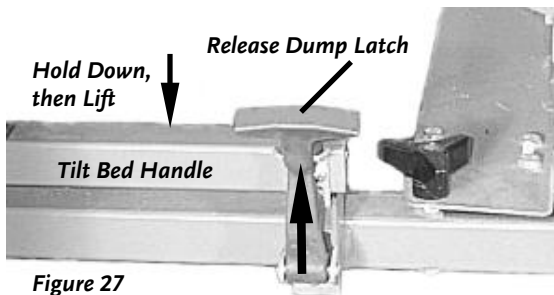

Figure 27

1. Disconnect the Collector Box Hose from the Blower Exit Elbow by releasing the two Flexible Latches (**Figure 26**) and separate the hoses.
2. Remove the Rear Panel of the Collector Box by releasing the six (6) fasteners located at the sides, top and bottom of the panel. Lift the Rear Panel off the mounting pins on the Collector Box Cover.
3. While holding down on the Tilt Bed Handle, release the Dump Latch (**Figure 27**) and raise the Tilt Bed using the Tilt Bed Handle (**Figure 27**).
4. After dumping the load, lower the Tilt Bed, reattach the Dump Latch and replace the Rear Panel.
5. Re-connect the Collector Box Hose to the Blower Exit Elbow.

**Tip:** Give the Tilt Bed Handle a little shake after emptying the Collector Box to loosen up the remaining material. Then drive forward about a foot with the Collector Box in the dump position. Shake the Tilt Bed Handle again and then lower the Tilt Bed back down and secure the Dump Latch. This usually gets all but a small amount of material to dump from the Collector Box. Clean or wipe away the remaining material and you are ready to reinstall the Rear Panel.

**Tip:** For heavy loads, it may be necessary to manually remove part of the load to reduce the tipping effort.

## Use as a Trailer

The DR LEAF and LAWN VACUUM may be used as a trailer (300 lbs. MAX) to haul firewood, stones, brush, etc., around your property. There are a few options available to use your DR LEAF and LAWN VACUUM as a trailer.

### **! WARNING!**

- WHEN USING THE DR LEAF AND LAWN VACUUM AS A TRAILER, NEVER ALLOW PEOPLE OR ANIMALS TO RIDE IN OR ON THE TRAILER.
- SECURE THE LOAD TO PREVENT IT FROM SHIFTING.

### **! NOTICE!**

THE TRAILER IS NOT EQUIPPED FOR HIGHWAY USE.

- Remove just the Rear Panel (*Figure 28*) or,
- Remove just the Front and Rear Panels or,
- Remove the Front and Rear Panels, and the Centrifugal Separator (Top) or,
- Remove all the panels and use as flat bed trailer.
- The trailer may also be used with the Blower/Chipper Engine removed (See page 42).

To assemble the desired configuration, refer to the Collector Box Installation section on page 16.



*Figure 28*

## LEAF and LAWN VACUUM Tips

**Tip:** For the most efficient use of the DR LEAF and LAWN VACUUM, use this sequence of steps:

---

### **WARNING!**

**PICKUP STONES, METAL OBJECTS, GLASS AND STICKS BEFORE VACUUMING.**

---

1. Gather and pile sticks to be chipped.
2. Chip the smaller sticks and branches.
3. Remove the rear panel and load the larger limbs (*Figure 28*).
4. Dump the load at the desired location.
5. Mow and vacuum leaves.

**Tip:** Eyebolts have been provided on the sides of the Collector Box so that you can attach accessories or other tools to transport them around the work site. Items can be attached with ropes or elastic (Bungee) cords provided by the user.

**Tip:** The lawn deck will tend to scatter some leaves in front and to the right of the lawn deck. Keeping this discharge side toward the remaining leaves will simplify cleanup by avoiding blowing leaves back onto the areas that you already finished. When you need to vacuum with the discharge side toward the completed area of the lawn, then overlap the discharge side of the lawn deck at least a foot over the already completed section of the lawn.

**Tip:** Drive your DR LEAF and LAWN VACUUM into the corner of your property and back out straight to mow as close to the corner as possible. Be sure to stay away from fences when you want to turn, as the back will swing wide during a turn. Avoid going thru ditches.

**Tip:** To prevent clogging the lawn deck adapter and vacuum hose, mow grass that is dry and not more 2" at a time. Cutting less than 1/3 the grass height is recommended to keep your grass healthy.

**Tip:** Run your lawn deck with your tractor at full throttle all the time to maximize the lift from your lawn deck and assist your DR LEAF and LAWN VACUUM system.

**Tip:** Avoid dragging the Inlet Hose over curbs, stonewalls or piles of cut branches. The hose is tough, but can puncture on sharp objects. This could also crack the Mower Deck Adapter.

## MAINTAINING THE DR LEAF AND LAWN VACUUM

Regular maintenance is the way to ensure the best performance and long life of your DR LEAF and LAWN VACUUM. Please refer to this manual and the engine owner manual for maintenance procedures. Service intervals listed in the checklist below supercede those listed in the engine owner manual.

**! WARNING!**

**WHEN PERFORMING ANY MAINTENANCE, YOU MUST FIRST SHUT OFF THE ENGINE AND DISCONNECT THE SPARK PLUG WIRE. READ THE "SAFETY CONSIDERATIONS" SECTION OF THIS MANUAL BEFORE PERFORMING ANY REPAIRS OR MAINTENANCE.**

### Regular Maintenance Checklist

*NOTE: Service intervals shown are considered maximum under normal operating conditions. Increase frequencies under extremely dirty or dusty conditions.*

Procedure	Before Each Use	Every 20 Hours	Every 100 Hours
Check Engine Oil Level	▲		
Check blower hoses for wear, holes, or abraded areas.	▲		
Check the general condition of the machine, e.g. nuts, bolts, welds, etc.	▲		
Make sure engine retaining knobs are tight.	▲		
Check Tire Pressure to be 40 psi.		▲	
Clean Engine Air Filters		▲	
Change Engine Oil <i>NOTE: 1<sup>st</sup> time after 5 hours of operation</i>		▲	
Clean Engine Exterior & Cooling Fins		▲	
Check Battery Charge		▲	
Replace Spark Plug			▲
Replace Engine Air Filters			▲

## **Lubrication**

Your DR LEAF and LAWN VACUUM was lubricated at the Factory. The operator needs to provide engine lubrication and lubricate the caster wheel spindles periodically.

### **Supplies Needed:**

- Grease gun with #2 Lithium Grease

Lubricate each caster wheel spindle with #2 Lithium grease using a grease gun on the fitting (**Figure 29**).



**Figure 29**



## Removing and Replacing the Engine Oil

### **! WARNING!**

WHEN PERFORMING ANY MAINTENANCE, YOU MUST FIRST SHUT OFF THE ENGINE AND DISCONNECT THE SPARK PLUG WIRE.

### **! NOTICE!**

BE CERTAIN TO FILL WITH OIL BEFORE STARTING THE ENGINE. SEE PAGE 25.

#### Tools & Supplies Recommended:

- 1/2" wrench
- SAE 30 HD, 20 oz. (0.60L)

**NOTE:** Drain the oil when the engine is warm. Warm oil drains quickly and completely.

1. Position a suitable oil receptacle under the engine oil drain and remove the engine oil Fill Cap (**Figure 30**).
2. Remove the engine oil Drain Plug counterclockwise using the 1/2" wrench (**Figure 30**).
3. Allow the used oil to drain completely, then reinstall the Drain Plug and tighten securely.
4. Replace the engine oil using SAE 30 HD oil. See page 25.
5. Replace the spark plug wire.

**NOTE:** If the oil is not to be reused, be sure to use environmentally safe disposal procedures in the disposing of the used oil.

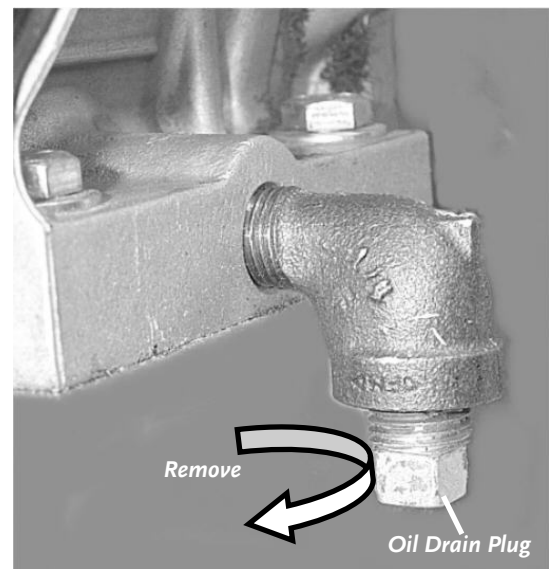
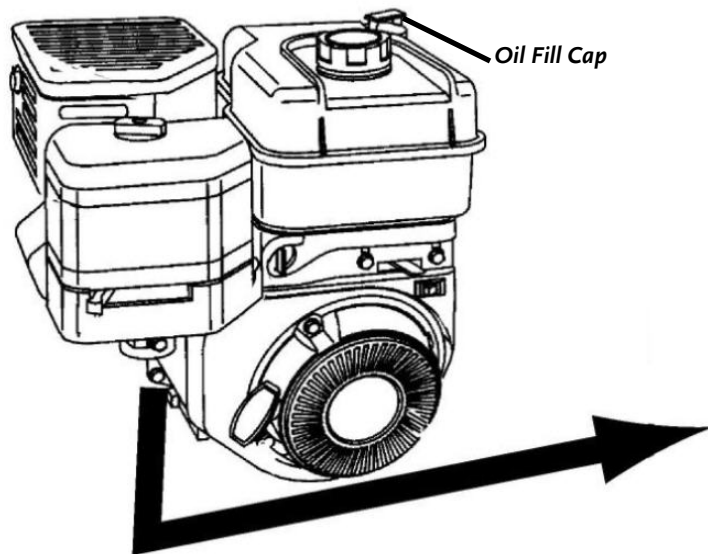

Left Side

Figure 30

## **Battery Care (For Electric-Starting Models Only)**

Proper care can extend the life of a battery. Follow these recommendations to ensure your battery's best performance and long life:

- Do not allow the battery charge to get too low. If the machine is not used, the battery should be charged every 4 – 6 weeks. Engine must be operated for at least 45 minutes to maintain proper battery charge.
- Store an unused battery in a dry area that does not freeze.
- Do not charge an already charged battery. In theory, our battery cannot be overcharged with a trickle charger; however, when a battery is fully charged and the charger is still on, it generates heat that could be harmful to the battery. A fully charged battery will read 12V-13.2V with a voltmeter.
- Do not continue to crank your engine when the battery charge is low.

### **Symptoms of a battery needing a charge:**

- The machine won't start with the key, but will start with the recoil starter.
- A whirring noise coming from the starter.
- A grinding noise and a whirring noise coming from the starter.
- No noise at all.

## **Charging the Battery**

The vacuum engine must be operated for at least 45 minutes to maintain proper battery charge. If the battery loses its charge, you'll need to use a trickle charger (like the DR Battery Charger) to recharge it. The charger should have an output of 12 volts at no more than 2 amps.

- At 1 amp the battery may need to be charged for as long as 48 hours.
- At 2 amps, the battery may need to be charged for as long as 24 hours.

**NOTE:** *Using the recoil starter and then running the engine will not recharge a dead or significantly discharged battery.*

To connect a battery charger to your DR LEAF and LAWN VACUUM, follow the steps listed below.

1. Detach the two battery wires going to the wiring harness on your DR LEAF and LAWN VACUUM.
2. Attach the black (-) battery charger wire to the black (-) wire, and attach the red (+) battery charger wire to the red (+) wire.
3. Plug the battery charger into an outlet.

---

### **NOTICE!**

**WHEN YOU ARE FINISHED CHARGING THE BATTERY, DISCONNECT THE BATTERY CHARGER WIRES FROM THE BATTERY FIRST, THEN DISCONNECT THE CHARGER FROM THE OUTLET. IF THE BATTERY CHARGER WIRES ARE LEFT CONNECTED TO THE BATTERY, THE BATTERY WILL DISCHARGE ITSELF BACK INTO THE CHARGER.**

---

## Removing and Replacing the Blower Hoses

### **WARNING!**

WHEN PERFORMING ANY MAINTENANCE, YOU MUST FIRST SHUT OFF THE ENGINE AND DISCONNECT THE SPARK PLUG WIRE.

#### Collector Box Hose:

#### Tools Needed:

- Diagonal or wire cutter
  - Screwdriver or nut driver
1. Disconnect the Collector Box Hose from the Blower Exit Elbow by loosening the Hose Clamp with a screwdriver or nut driver (**Figure 31**) and separating the hose from the Connector Fitting. Leave the loose clamp on the fitting.
  2. Tilt the trailer bed back for ease of access and cut the Hose Support Tie Strap (**Figure 32**).
  3. Remove the hose from the inlet of the Centrifugal Separator by grasping the hose and unscrewing it, clockwise (**Figure 33**).
  4. Install the new hose by turning the hose counterclockwise into the inlet opening of the Centrifugal Separator. Turn the hose in until about 4 or 5 of the hose ribs have entered the opening.
  5. Lower the Tilt Bed, secure in place, and slip the remaining end of the hose onto the Connector Fitting on the Blower Exit Elbow.
  6. Adjust the hose length if the hose sags away from the Collector Box. Remove any excess hose from the end attached to the Blower Exit Elbow.

**Tip:** Determine the length of hose to be removed by holding the hose tight beside the Connector Fitting. Mark the place to cut the hose. Cut the hose spiral with a diagonal cutter and then cut the hose with a razor knife.

7. Slip the hose back onto the Connector Fitting, slide the Hose Clamp up on the hose and tighten.

**NOTE:** Make sure that the clamp is on the blower side of the raised rivet in the connector sleeve to prevent the hose from slipping off after the clamp is tightened.

8. Replace the Hose Support Tie Strap with the new one supplied with the replacement hose (**Figure 32**).

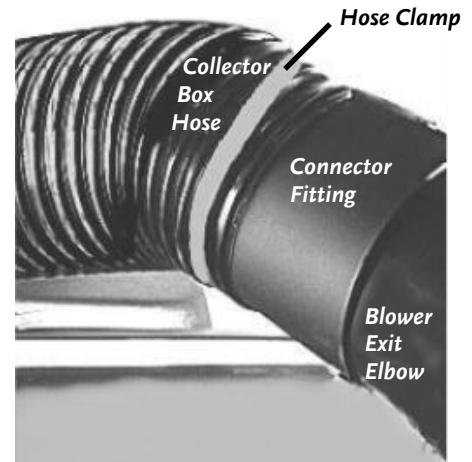

Figure 31

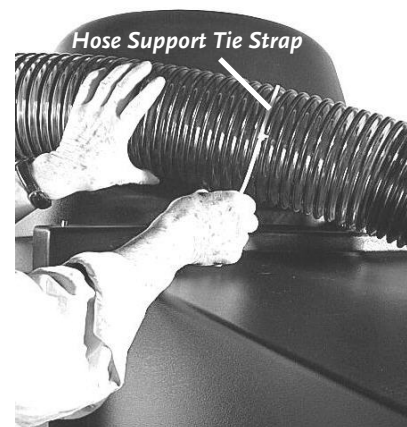

Figure 32

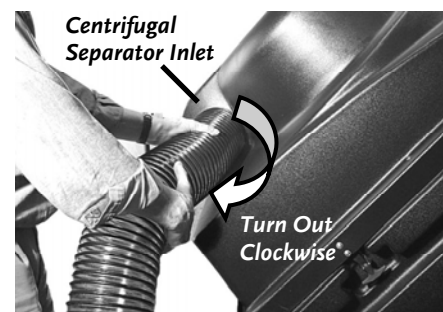

Figure 33

## **! WARNING!**

WHEN PERFORMING ANY MAINTENANCE, YOU MUST FIRST SHUT OFF THE ENGINE AND DISCONNECT THE SPARK PLUG WIRE.

### Blower Inlet Hose:

#### Tool Needed:

- Screw driver or nut driver
1. Loosen the Hose Clamps retaining the Inlet Hose at the Inlet Hose Adapter and the connector fitting at the opposite end of the hose. Then slip the hose off the adapter and fitting (**Figure 35** on page 41).
  2. Install the new hose in the reverse order making sure that the clamps are positioned on the blower side of the raised rivet in the Inlet Hose Adapter and on the fitting side of the raised rivet in the connector fitting to prevent the hose from slipping off after the clamps are tightened.
  3. Check the Safety Interlock Switch to be sure that it is engaged.

## **Removing and Replacing the Blower Exit Elbow**

## **! WARNING!**

WHEN PERFORMING ANY MAINTENANCE, YOU MUST FIRST SHUT OFF THE ENGINE AND DISCONNECT THE SPARK PLUG WIRE.

1. Disconnect the Blower Exit Elbow to the Collector Box Hose by releasing the two flexible latches (**Figure 34**) and separate the hose.
2. Remove the four (4) Wing Screws from the Blower Exit Elbow Assembly (**Figure 34**).
3. Lift the Blower Exit Elbow Assembly from the top of the Blower and install a new assembly in the reverse order (**Figure 34**).
4. Check the Safety Interlock Switch to be sure that it is engaged.

**NOTE:** If the Safety Interlock Switch is not engaged, adjust the switch mounting bracket by loosening the bracket bolt and sliding the bracket up so that the button on the switch is fully depressed against the Blower Exit Elbow Assembly. See page 18.

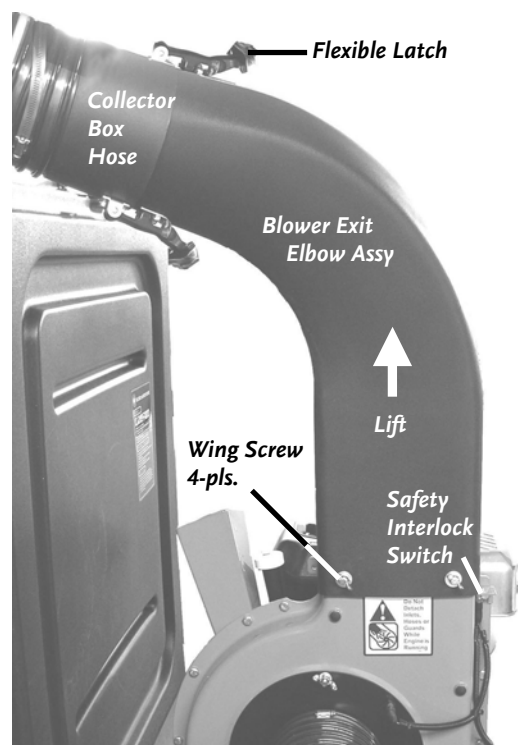

Figure 34

## Removing and Replacing the Chipper Blade

### **! WARNING!**

- WHEN PERFORMING ANY MAINTENANCE, YOU MUST FIRST SHUT OFF THE ENGINE AND DISCONNECT THE SPARK PLUG WIRE.
- DO NOT ATTEMPT TO RE-SHARPEN THE CHIPPER BLADE. THIS WILL UNBALANCE THE IMPELLER AND MAY DAMAGE THE ENGINE AND BLOWER. ALWAYS REPLACE A DULL OR DAMAGED CHIPPER BLADE WITH A NEW BLADE.

#### Tools Needed:

- (2) 1/2" wrench or socket
- 9/16" wrench or socket
- 3/16" Allen wrench

1. Disconnect the Blower Exit Elbow Assembly from the Collector Box Hose (**Figure 34**).
2. Remove the Wing Nuts and Wing Screws to disconnect the Inlet Hose Adapter and Blower Exit Elbow Assembly from the Chipper/Blower unit (**Figure 35**).
3. Using two (2) 1/2" wrenches or sockets, remove the 12 Bolts & Nuts retaining the Blower Cover Plate (**Figure 35**) and remove the plate from the blower housing. The Chipper Impeller is now exposed.
4. Using the 9/16" wrench or socket, remove the Chipper Impeller retaining Bolt (**Figure 36**) from the engine shaft and slide the impeller off of the shaft. Be sure to save the key in the slotted shaft.
5. The Chipper Blade is attached to the impeller with three (3) Allen head screws and three (3) nylon lock nuts (**Figure 36**). Using the 3/16" Allen wrench and 1/2" wrench, remove the old Chipper Blade by removing the three (3) screws and nuts.

**NOTE:** Carefully observe the orientation of the chipper blade edge and mounting holes when removing the blade.

6. Install the new Chipper Blade and Impeller in the reverse order making sure the key is installed in the engine shaft keyway.

**NOTE:** If the Safety Interlock Switch is not engaged, adjust the switch mounting bracket by loosening the bracket bolt and sliding the bracket up so that the button on the switch is fully depressed against the Blower Exit Elbow Assembly. See page 18.

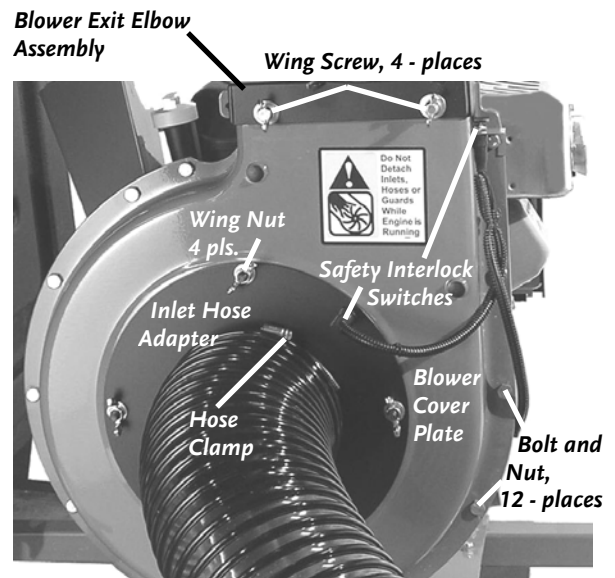

Figure 35

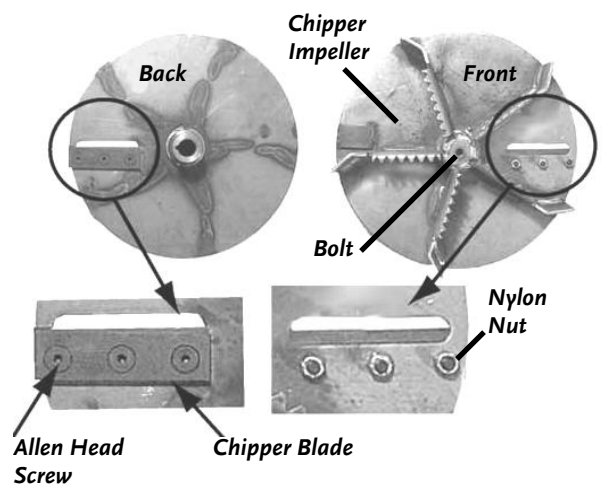

Figure 36

## Removing the Blower/Chipper Engine Unit

### **! WARNING!**

- BEFORE PERFORMING ANY MAINTENANCE PROCEDURE, STOP THE ENGINE AND DISCONNECT THE SPARK PLUG WIRE.
- BEFORE PERFORMING THIS PROCEDURE, ASSURE THAT YOUR DR LEAF AND LAWN VACUUM IS ON LEVEL TERRAIN AND THE BRAKE IS SET ON YOUR LAWN TRACTOR.
- DO NOT USE CHIPPER OR VACUUM FEATURES WITHOUT FIRST SECURING THE ENGINE TO THE FRAME AND SECURING THE HOSES.

1. Disconnect Collector Box Hose from the Blower Exit Elbow (**Figure 34** on page 40).
2. Remove the Inlet Hose by loosening the Hose Clamp (**Figure 35** on page 41).
3. Remove the Hitch Clips from the Clevis Pins and remove the pins (**Figure 13** on page 20). Move the trailer hitch from the tractor hitch plate and set it on level ground.
4. Remove (turn counterclockwise) the four retaining knobs holding the engine plate to the trailer frame (**Figure 37**).
5. With the help of another person, carefully lift the engine off the mounting studs and set it on the attached engine dolly wheels (**Figure 38**).
6. Store the engine assembly in a dry location.
7. Reverse this procedure to re-install the engine unit then refer to page 20, "Connecting the DR LEAF and LAWN VACUUM to your Lawn Tractor".
8. Check the Safety Interlock Switch. See page 18.

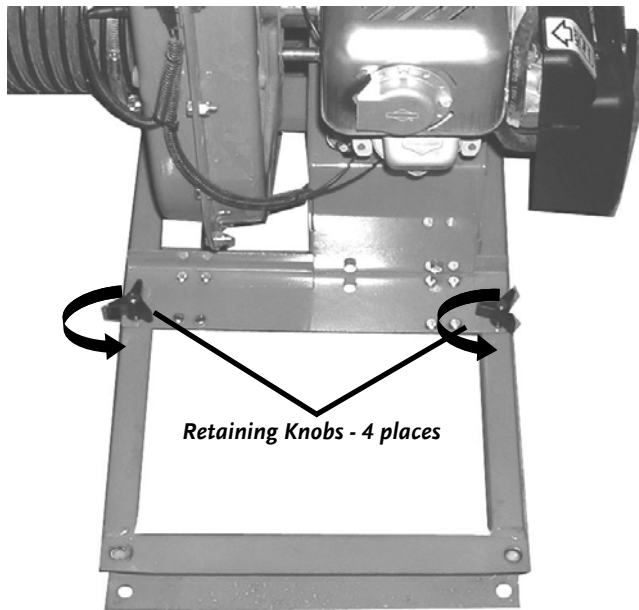

Figure 37



Figure 38

## End of Season and Storage

---

### **WARNING!**

**BEFORE PERFORMING ANY MAINTENANCE PROCEDURE, STOP THE ENGINE AND DISCONNECT THE SPARK PLUG WIRE.**

---

**NOTE:** *Please refer to the engine owner's manual for engine-specific procedures.*

- Change the oil.
- If your DR LEAF and LAWN VACUUM will be idle for more than 30 days, we recommend using a gas stabilizer. This will prevent sediment from gumming up the carburetor. If there is dirt or moisture in the gas or tank, remove it by draining the tank. Completely fill the tank with fresh, unleaded gas and add the appropriate amount of stabilizer or gasoline additive. Run the engine for a short time to allow the additive to circulate.
- Remove the spark plug and pour about 1 ounce of motor oil into the cylinder hole. Replace the plug and pull the recoil starter rope until you feel strong resistance. This will coat the piston and seat the valves to prevent moisture buildup.
- Clean/replace the air filter.
- Clean dirt and debris from the cylinder head cooling fins, blower housing, debris screen and muffler area of the engine.
- Clean out residual debris from the blower hoses and Collector Box.
- If the DR LEAF and LAWN VACUUM will be used as a trailer during the end of season, we recommend that you remove and store the engine in a dry location. See page 42.
- For minimal storage space, you can disassemble the Collector Box by removing the Rear & Front Panels, Centrifugal Separator (Top), and the Side Panels. The Collector Box pieces then can be stacked against a wall in a convenient location. See page 16 for disassembly and re-assembly of the Collector Box.
- Store the battery in a dry area that will not freeze. If the machine is not used over a long period, the battery should be charged every four to six weeks. See page 38.

## TROUBLESHOOTING

Most problems are easy to fix. Consult the troubleshooting table for common problems and their solutions. If you continue to experience problems, call Country Home Products, Inc. for support.

### *Troubleshooting Table*



#### **WARNING!**

**BEFORE PERFORMING ANY MAINTENANCE PROCEDURE, STOP THE ENGINE AND DISCONNECT THE SPARK PLUG WIRE.**

SYMPTOM	POSSIBLE CAUSE
<p><i>Recoil will not pull out or is difficult to pull.</i></p>	<ul style="list-style-type: none"> <li>⇒ Check for debris in the Chipper Hopper.</li> <li>⇒ Check the engine oil level, the engine may be seized.</li> <li>⇒ There may be an oil compression lock in the cylinder. Take out the spark plug, hold a rag over the spark plug hole and pull the recoil cord several times to blow out any oil in the cylinder. Wipe off the spark plug and reinstall it.</li> <li>⇒ The recoil may be broken or jammed. Call <b>1(800) DR-OWNER (376-9637)</b> for assistance.</li> </ul>
<p><i>The engine won't start manually.</i></p> <p><i>(Please refer to the engine owner's manual for engine-specific procedures.)</i></p>	<ul style="list-style-type: none"> <li>⇒ Check that the spark plug wire is attached.</li> <li>⇒ Check the oil and gas level. See page 25.</li> <li>⇒ Are you using fresh, clean gas? If the gas is old, change it. Use a fuel stabilizer if you keep gas longer than one month.</li> <li>⇒ Check the throttle adjustment and travel. See page 26.</li> <li>⇒ Is the spark plug clean? If the spark plug is dirty or cracked, change it. If it's oily, leave it out, hold a rag over the plug hole and pull the recoil cord several times to blow out any oil in the cylinder, then wipe off the plug and reinsert it.</li> <li>⇒ Check that the Safety Interlock Switch is depressed. See page 18 <b>Figure 10</b> and page 41 <b>Figure 35</b>.</li> <li>⇒ If your engine still won't start, call <b>1(800) DR-OWNER (376-9637)</b> for assistance.</li> </ul>



**! WARNING!**

**BEFORE PERFORMING ANY MAINTENANCE PROCEDURE, STOP THE ENGINE AND DISCONNECT THE SPARK PLUG WIRE.**

SYMPTOM	POSSIBLE CAUSE
<p><i>The engine won't start using electric-start.</i></p> <p><i>(Please refer to the engine owner's manual for engine-specific procedures.)</i></p>	<ul style="list-style-type: none"> <li>⇒ Check the previous section (Manual Starting) for possible causes.</li> <li>⇒ There is a fuse in the wiring harness. Check the fuse and replace if needed.</li> <li>⇒ Check the wire connections—especially the ground connection, the large green wire coming from the battery, where it connects to the engine.</li> <li>⇒ Check the wire connections to the solenoid. Disconnect the green battery ground wire first to avoid sparks. Check to be sure that all of the connections are clean and tight. Reconnect the battery ground wire.</li> <li>⇒ Check the ground connection on the solenoid where it's bolted to the frame. Using a wrench or socket, tighten the bolts to ensure a good connection to the frame.</li> <li>⇒ Is your battery charged? Check the voltage yourself or at a gas station. If it's low, charge it with a 12-volt, 1 to 2 Amp trickle charger. If you don't use your vacuum for at least 45 minutes at a time, the battery may need to be periodically charged. See the Battery Care section on page 38.</li> <li>⇒ If your battery is charged and your DR still won't start, call <b>1(800) DR-OWNER (376-9637)</b> for assistance.</li> </ul>
<p><i>The engine lacks power or is not running smoothly.</i></p> <p><i>(Please refer to the engine owner's manual for engine-specific procedures.)</i></p>	<ul style="list-style-type: none"> <li>⇒ Check the throttle travel. See page 26.</li> <li>⇒ Is the choke pushed all the way to the left (RUN)? See page 26.</li> <li>⇒ Is the air filter clean? If it's dirty, change it following the procedure in the engine owner's manual.</li> <li>⇒ Is the spark plug clean? If it's fouled or cracked, change it. If it's oily, leave it out, hold a rag over the plug hole and pull your recoil cord several times to blow out any oil in the cylinder, then wipe off the plug and reinsert it.</li> <li>⇒ Are you using fresh, clean unleaded gas? If it's old, change it. Use a fuel stabilizer if you keep gas longer than one month.</li> <li>⇒ Does your engine have the right amount of clean oil? If it's dirty, change it following the procedure in the engine manufacturer's owner's manual.</li> <li>⇒ Check the oil level and adjust as needed.</li> <li>⇒ If your engine still lacks power, call <b>1(800) DR-OWNER (376-9637)</b> for assistance.</li> </ul>
<p><i>Engine smokes.</i></p>	<ul style="list-style-type: none"> <li>⇒ Check the oil level and adjust as needed.</li> <li>⇒ Check the air filter and clean or replace if needed.</li> <li>⇒ You may be using the wrong oil—too light for the temperature. Refer to your Engine Owner's Manual for detailed information.</li> <li>⇒ Clean the engine cooling fins and the carburetor housing if they're dirty.</li> <li>⇒ If the engine still smokes, call <b>1(800) DR-OWNER (376-9637)</b> for assistance.</li> </ul>

**! WARNING!**

**BEFORE PERFORMING ANY MAINTENANCE PROCEDURE, STOP THE ENGINE AND DISCONNECT THE SPARK PLUG WIRE.**

SYMPTOM	POSSIBLE CAUSE
<i>Trailer wheels tracking left or right while being towed.</i>	⇒ Check the tire pressure. There should be 40 psi in each tire.
<i>Vibrations higher than normal.</i>	⇒ Check for Chipper Blade damage. See page 41. <b>NOTE:</b> <i>The Chipper Blade cannot be sharpened and must be replaced if damaged.</i>
<i>Lawn deck is not vacuuming well.</i>	<ul style="list-style-type: none"> <li>⇒ Be sure the lawn deck blades are engaged and running at full throttle.</li> <li>⇒ Be sure the deck is set at the proper mowing height.</li> <li>⇒ Be sure the vacuum engine is running at full throttle.</li> <li>⇒ Use 1<sup>st</sup> or 2<sup>nd</sup> gear on your lawn tractor for best results.</li> <li>⇒ Look for clogs along the Collector Box Inlet Hose. Shake the hose to loosen and free any clog.</li> <li>⇒ Turn off the lawn tractor engine and vacuum engine, and check the Hose Adapter for clogs. See page 23.</li> <li>⇒ Turn off the lawn tractor engine and vacuum engine, and disconnect the vacuum engine spark plug wire. Check for clogs in the Blower Exit Elbow and Inlet Hose. Remove the hose and shake clogs loose. See page 40.</li> <li>⇒ If your lawn deck still is not vacuuming properly, call <b>1 (800) DR-OWNER (376-9637)</b> for assistance.</li> </ul>
<i>Leaves or grass come out of the top of the Centrifugal Separator and the Collector Box is not full.</i>	<ul style="list-style-type: none"> <li>⇒ Check for clogs along the edges of the Centrifugal Separator cone.</li> <li>⇒ Check the Collector Box Inlet Hose to be sure it is about 4 to 6 inches inside the Centrifugal Separator inlet and approximately level. See page 39.</li> </ul>
<i>Leaves or grass come out of the top of the side panels.</i>	<ul style="list-style-type: none"> <li>⇒ Be sure the pin is in the hole in the center of the top of the side panels. See page 16.</li> <li>⇒ Be sure all of the panel flexible latches are secure.</li> </ul>



---

**PARTS LISTS, SCHEMATIC DIAGRAMS AND WARRANTY**
**Parts List - Trailer Assembly**

*NOTE: Part numbers listed are available through Country Home Products.*

<b>Ref#</b>	<b>Part#</b>	<b>Description</b>
01	180721	Frame
02	188671	Bushing, 1" ID x 1-1/4" OD
03	188781	Support, Axle
04	188771	Caster
05	186721	Wheel with Hub and Bushing, 13"
06	112411	Washer, Flat, 5/16" USS
07	111581	Bolt, HCS, 5/16"-18 x 1"
08	187241	Axle, Tapped
09	126851	Pin, Cotter, 3/16" x 1-1/2"
10	189801	Bolt, HCS, 5/16"-18 x 4-1/2", GR.2, ZP
11	110761	Nut, Nylon Lock, 5/16"-18
12	186731	Latch, Draw
13	109341	Bumper, 1" OD x 1"
14	114781	Screw, Pan Head, 10-24 x 5/8"
15	118731	Nut, Nylon Lock, 10-24
16	101891	Grease Fitting, 1/4"-28, Straight
17	188381	Plate, Axle Support Doubler
18	112431	Washer, Lock, Split, 5/16"
19	111081	Plug, Cap, Square, 1"
20	187591	Plug, Cap, Square, 1-1/2"
21	164121	Pad, Bumper, Neoprene
22	123601	Bolt, HHCS, 5/16"-18 x 2-1/4" Full Thread, GR.5, ZP
23	187551	Nut, Low Profile, Nylon Lock, 5/16"-18, GR.2, ZP
24	187371	Pin, Clevis, 1/2" x 4-1/2", ZP
25	160031	Pin, Hitch Clip, 1/2" to 9/16", .12" Wire
26	187311	Bracket, Towing
27	189671	Washer, Flat, Rubber
28	111661	Screw, Self Tapping, 12 x 1"

**Optional – Not Shown**

189781 Narrow Hitch Plate

**Zero Turn Mower Kits**

193191 Toro Model Z Hitch Kit

193181 Toro Model ZX Hitch Kit

# Schematic Diagram - Trailer Assembly

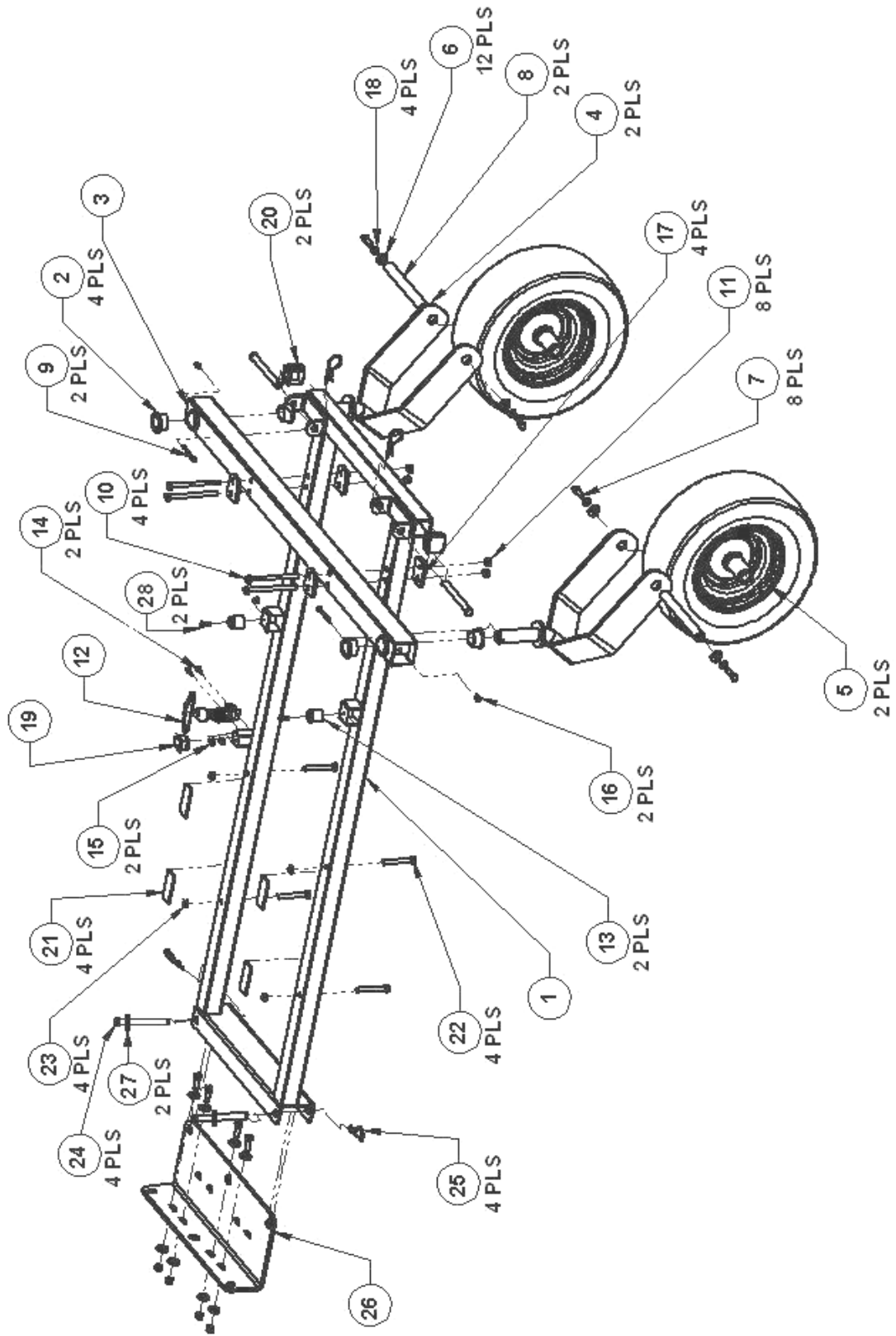

## **Parts List - Blower/Chipper Assembly**

**NOTE:** Part numbers listed are available through Country Home Products.

<b>Ref#</b>	<b>Part#</b>	<b>Description</b>	<b>Ref#</b>	<b>Part#</b>	<b>Description</b>
01	186911	Engine, 6.0 HP, B&S, M/S	29	Deleted	
	188681	Engine, 5.5 HP, B&S, M/S	30	186731	Latch, Draw
	193001	Engine, 6.0 HP, B&S, E/S	31	186961	Clamp, Hose, 6"
	192991	Engine, 5.5 HP, B&S, E/S	32	186771	Adapter, Male/Female, 6"
02	Deleted		33	186741	Hose, Inlet, 42"
03	112381	Washer, Flat, 1/4" USS	34	189291	Rivet, Blind, Alum., 3/16" Dia., x .312"
04	Deleted		35	Deleted	
05	186931	Engine Mount	36	Deleted	
06	134431	Bolt, 5/16"-18 x 1-1/2"	37	112411	Washer, Flat, 5/16"
07	110761	Nut, Nylon Lock, 5/16"-18			
08	187331	Impeller w/Knife (6.0 HP)			
	188691	Impeller w/o Knife (5.5 HP)			
09	188821	Bolt, HHCS, 3/8"-24 x 2-1/4", GR 8			
10	180811	Washer, Lock, 3/8"			
11	123211	Bolt, HCS, 5/16"-18 x 3/4"			
12	188331	Adapter, Hose, 6" to Chipper/Vacuum			
	187971	Adapter, Hose, 7" to 6"			
	187981	Adapter, Hose, 8" to 6"			
13	186901	Housing, Chipper, Front			
14	187321	Housing, Chipper, Back (6.0 HP)			
	188811	Housing, Chipper, Back (5.5 HP)			
15	189331	Nut, Wing, Nylon Lock, 5/16"-18			
16	187341	Chipper Hopper (6.0 HP)			
17	188761	Bolt, HCS, 5/16"-24 x 2-1/2" (6.0HP)			
	178821	Bolt, HCS, 5/16"-24 x 1" (5.5 HP)			
18	112431	Washer, Lock, Split, 5/16"			
19	189021	Caster, 2"			
20	188651	Bracket, Switch, Leaf System			
21	110731	Nut, Nylon, Lock, 1/4"-20			
22	114701	Bolt, HHCS, 1/4"-20 x 1/2"			
23	189301	Nut, Low Profile, 5/16"-24, ZP, GR2			
24	164141	Rivet, Blind, Alum., 3/16" Dia., x .1875"			
25	Deleted				
26	188701	Spacer, Impeller (6.0 HP)			
	193021	Spacer, Impeller (5.5 HP)			
27	164521	Key, Square, 1/4" x 1-1/4"			
28	188791	Knob, 5/16"			

### **Not Illustrated**

104831	Battery
192441	Battery Bracket
124511	Battery Clamp
150141	Ground Wire
113081	Key Switch
192501	Key Switch Bracket
192511	Wire Harness (Electric Starting only)
188721	Harness, Safety Switches
189711	Elbow, Street, Oil Drain
188951	Stand-Off, 6.0 HP Engine only
193031	Stand-Off, 5.5 HP Engine only
180281	Spacer, .750" OD x .328" ID

# Schematic Diagram - Blower/Chipper Assembly

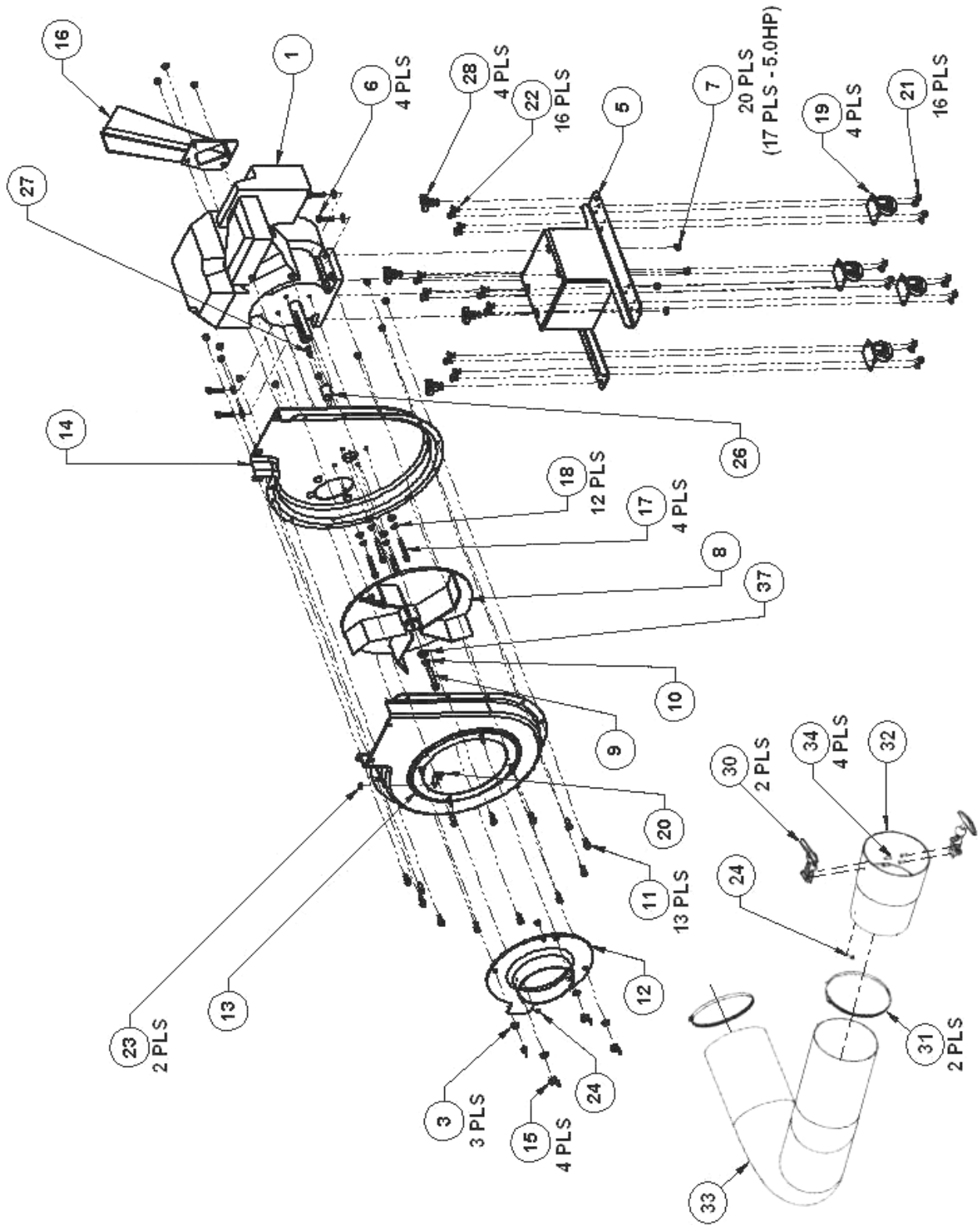

## Parts List - Centrifugal Separator, Hose and Blower Exit Elbow Assembly

**NOTE:** Part numbers listed are available through Country Home Products.

Ref#	Part#	Description
01	186831	Centrifugal Separator
02	114781	Screw, Pan Head, 10-24 x 5/8"
03	118731	Nut, Nylon Lock, 10-24
04	112371	Washer, Flat, 10-24 USS
05	175521	Bolt, Eye, 10-24 x 1/2"
06	186731	Latch, Draw
07	186811	Rod, Threaded, 3/8"-16 x 8"
08	110751	Nut, Nylon Lock, 3/8"-16
09	112391	Washer, Flat, 3/8", USS
10	186801	Cone, Centrifuge
11	188971	Rivet, Nut, Closed End, 10-24
12	Deleted	
13	126831	Nut, 3/8"-16, ZP
14	186741	Hose, Male/Female to Centrifugal Separator, 50"
15	186961	Clamp, Hose, 6"
16	186771	Adapter, Male/Female, 6"
17	164141	Rivet, Blind, Alum., 3/16" Dia. x .1875"
18	189291	Rivet, Blind, Alum., 3/16" Dia. x .312"
19	193041	Elbow, Blower Exit
20	Deleted	
21	Deleted	
22	189441	Keeper, Draw Latch, 4"
23	Deleted	
24	189311	Screw, Wing Head, 5/16"-18 x 3/4"
25	112431	Washer, Lock, Split, 5/16"
26	112411	Washer, Flat, 5/16"



# Schematic Diagram - Centrifugal Separator, Hose and Blower Exit Elbow Assembly

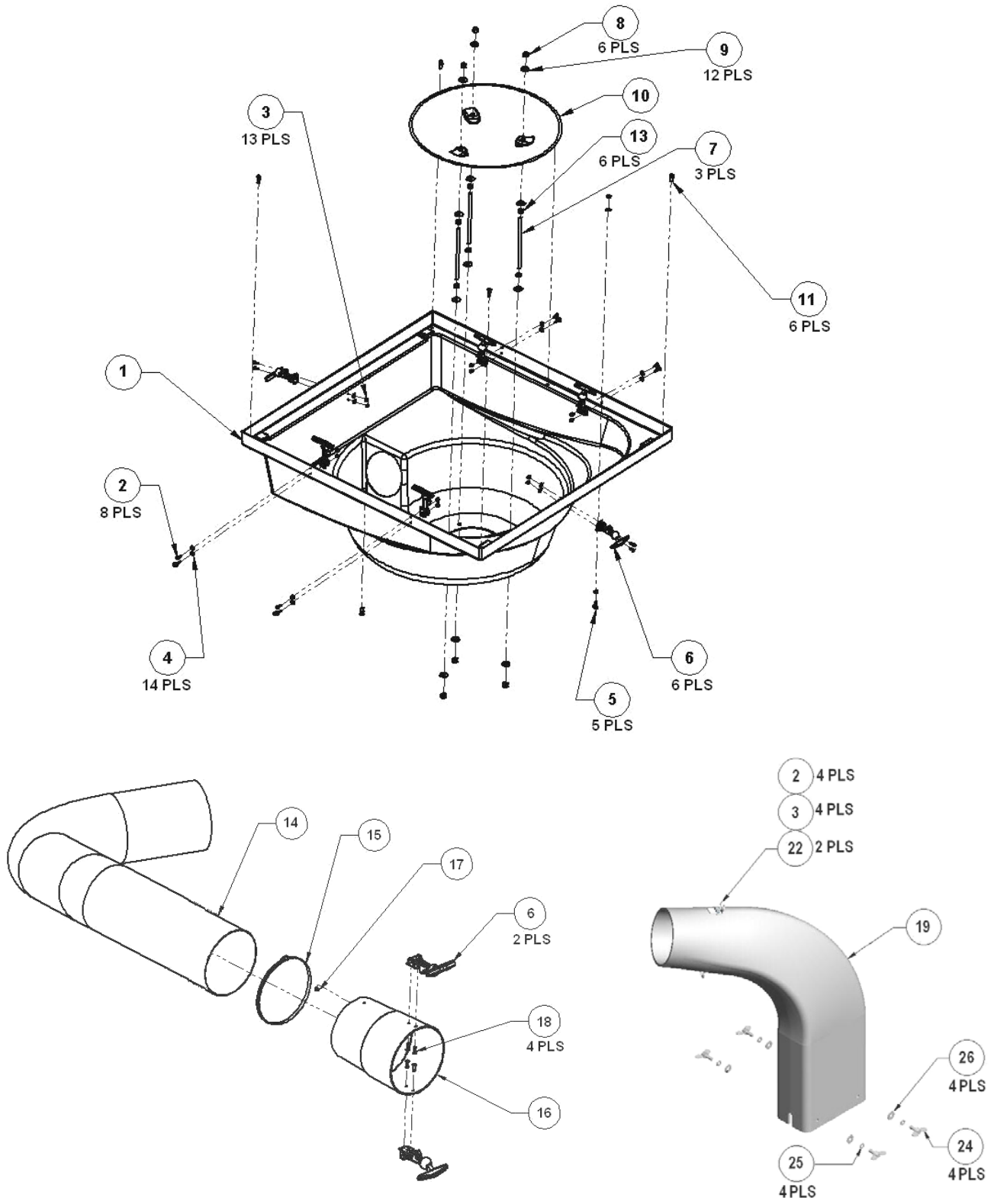

## **Parts List - Tilt Bed Assembly**

*NOTE: Part numbers listed are available through Country Home Products.*

<b>Ref#</b>	<b>Part#</b>	<b>Description</b>
01	110761	Nut, Nylon Lock, 5/16"-18
02	118731	Nut, Nylon Lock, 10-24
03	150451	Bolt, HCS, 5/16"-18 x 1-3/4"
04	187221	Handle, Dump, Tilt Bed
05	187581	Screw, PHS, 10-24 x 1-1/2"
06	111591	Bolt, HHCS, 5/16"-18 x 2-1/2"
07	186731	Latch, Draw
08	111081	Plug, Cap, Square, 1"
09	114781	Screw, Pan Head, 10-24 x 5/8"
10	112371	Washer, Flat, 10-24 USS
11	186711	Frame, Bed
12	186851	Base, Leaf System
13	189441	Keeper, Draw Latch, 4"
14	112381	Washer, Flat, 1/4" USS

**Schematic Diagram - Tilt Bed Assembly**

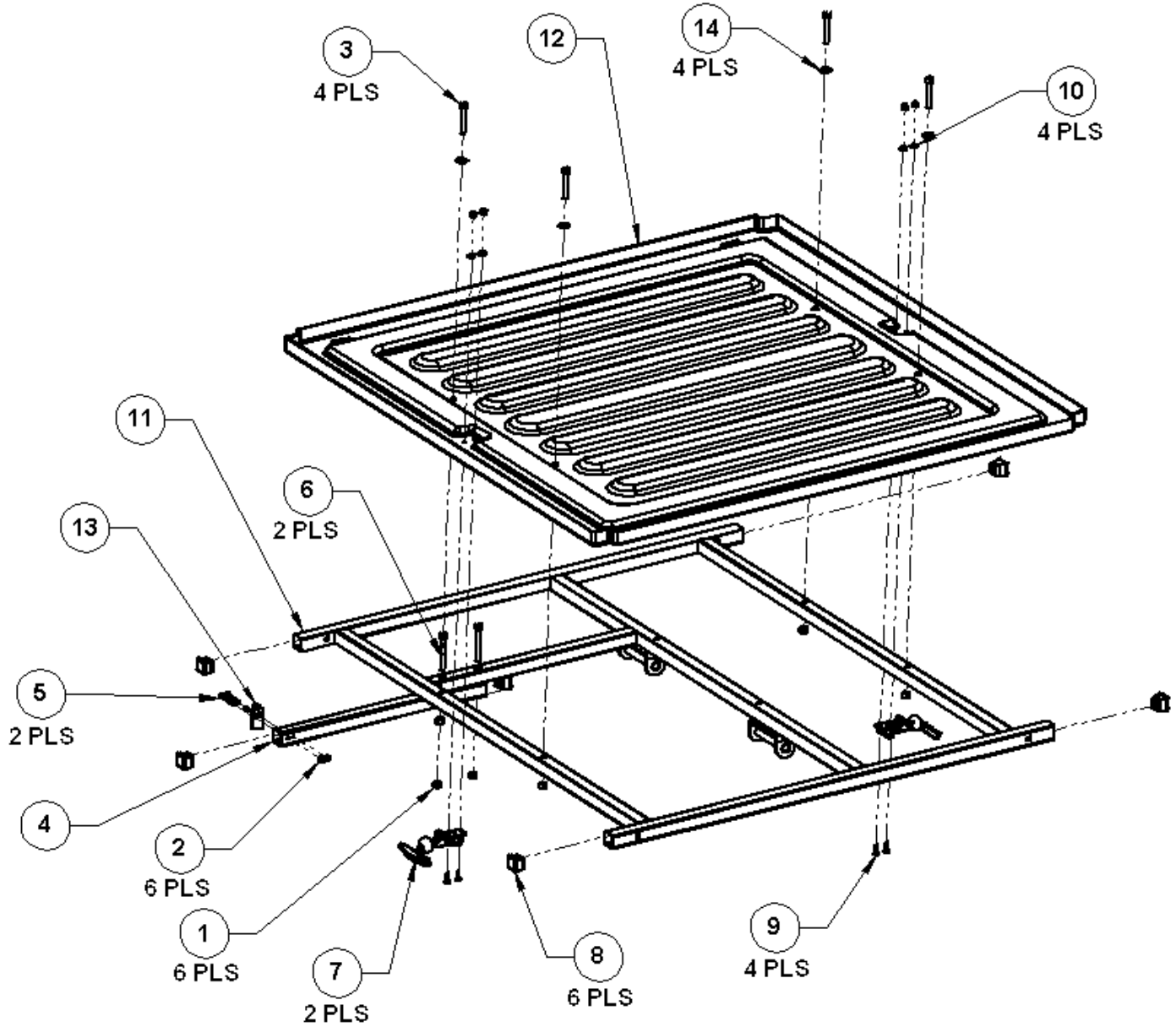

## **Parts List - Side and Rear Panel Assembly**

**NOTE:** Part numbers listed are available through Country Home Products.

<b>Ref#</b>	<b>Part#</b>	<b>Description</b>
01	190351	Side Panel Assembly
	186841	Side Panel
02	189441	Keeper, Draw Latch, 4"
03	187231	Support, Side
04	112381	Washer, Flat, 1/4" USS
05	111491	Bolt, HCS, 1/4"-20 x 1"
06	110731	Nut, Nylon Lock, 1/4"-20
07	189291	Rivet, Blind, Alum., 3/16" Dia. x .312"
08	189111	Insert, Side Panel
09	189321	Screw, Wing Head, 5/16" x 1-3/4"
10	118731	Nut, Nylon Lock, 10-24
11	112371	Washer, Flat, 10-24 USS
12	114781	Screw, Pan Head, 10-24 x 5/8"
13	190361	Rear Panel Assembly
	186861	Rear Panel
14	186731	Latch, Draw
15	188011	Support, Container
16	112431	Washer, Lock, 5/16"
17	112411	Washer, Flat, 5/16"

### Schematic Diagram - Side and Rear Panel Assembly

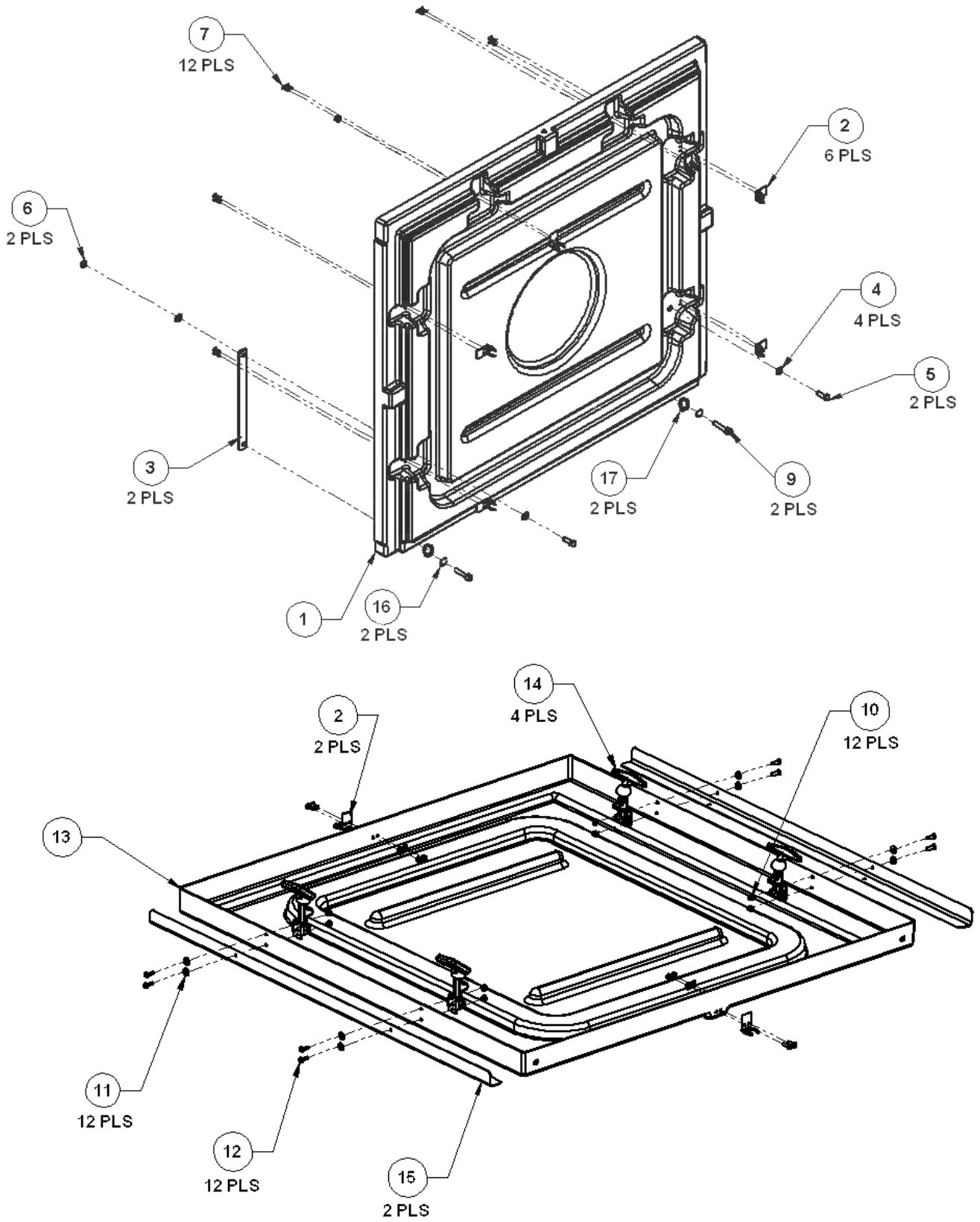

## Parts List - Front Panel Assembly

**NOTE:** Part numbers listed are available through Country Home Products.

Ref#	Part#	Description
01	190371	Front Panel Assembly
	186861	Front Panel
02	186731	Latch, Draw
03	189441	Keeper, Draw Latch, 4"
04	114781	Screw, Pan Head, 10-24 x 5/8"
05	118731	Nut, Nylon Lock, 10-24
06	112371	Washer, Flat, 10-24 USS

## Schematic Diagram - Front Panel Assembly

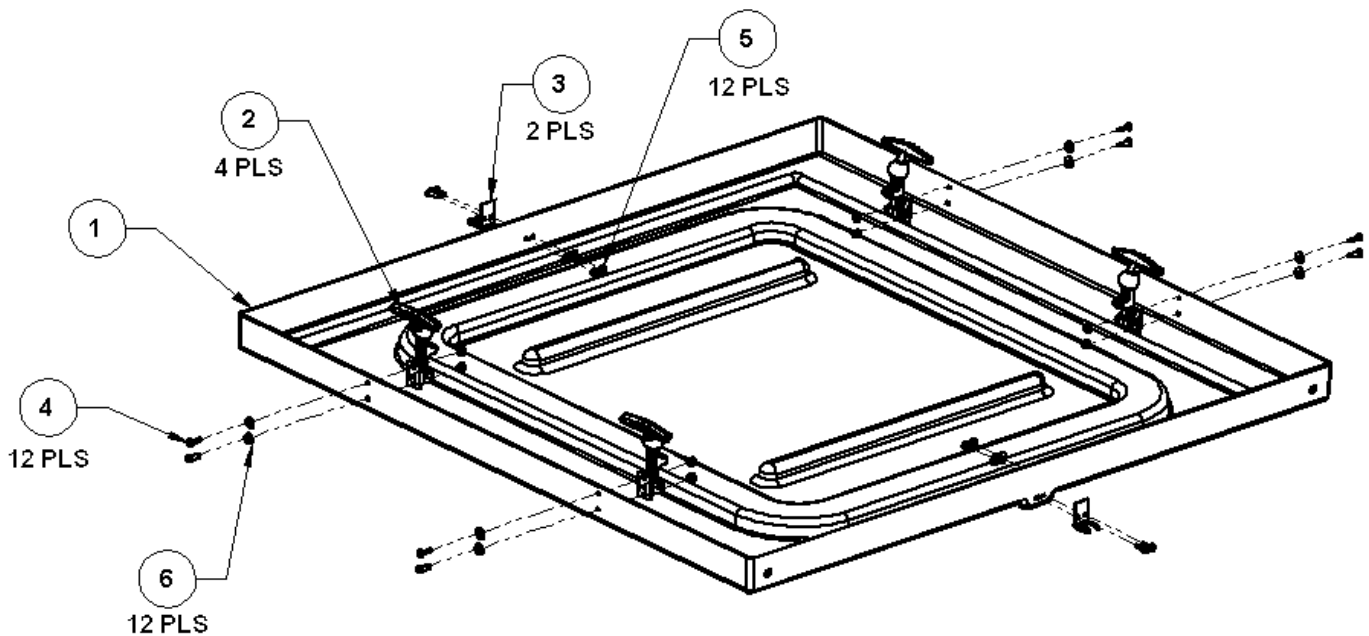

**NOTES**

**NOTES**



# DR<sup>®</sup> PREMIER LEAF and LAWN VACUUM



## 1-Year Limited Warranty

### Terms and Conditions

The DR<sup>®</sup> LEAF and LAWN VACUUM is warranted for one (1) year against defects in materials or workmanship when put to ordinary and normal consumer use; ninety (90) days for any other use. The engine manufacturer warrants the engine separately.

For the purposes of all the above warranties, "ordinary and normal consumer use" refers to non-commercial residential use and does not include misuse, accidents or damage due to inadequate maintenance.

Country Home Products, Inc. certifies that the DR<sup>®</sup> LEAF and LAWN VACUUM is fit for ordinary purposes for which a product of this type is used. Country Home Products, Inc. however, limits the implied warranties of merchantability and fitness in duration to a period of one (1) year in consumer use, ninety (90) days for any other use.

The 1-Year Limited Warranty on the DR<sup>®</sup> LEAF and LAWN VACUUM starts on the date the machine ships from our factory. The 1-Year Limited Warranty is applicable only to the original owner.

The warranty holder is responsible for the performance of the required maintenance as defined by the manufacturer's owner's manuals. The warranty holder is responsible for replacement of normally wearing parts such as the blower hoses, chipper blades, tires, battery and spark plug. Attachments and accessories to the machine are not covered by this warranty.

During the warranty period, the warranty holder is responsible for the machine transportation charges, if required. During the warranty period, warranty parts will be shipped by standard method at no charge to the warranty holder. Expedited shipping of warranty parts is the responsibility of the warranty holder.

SOME STATES DO NOT ALLOW LIMITATIONS ON THE LENGTH OF IMPLIED WARRANTIES, SO THE ABOVE LIMITATIONS MAY NOT APPLY TO YOU.

Country Home Products, Inc. shall not be liable under any circumstances for any **incidental or consequential damages or expenses** of any kind, including, but not limited to, cost of equipment rentals, loss of profit, or cost of hiring services to perform tasks normally performed by the DR<sup>®</sup> LEAF and LAWN VACUUM.

SOME STATES DO NOT ALLOW THE EXCLUSION OR LIMITATION OF INCIDENTAL OR CONSEQUENTIAL DAMAGES, SO THE ABOVE LIMITATIONS MAY NOT APPLY TO YOU.

### Customer Service Hotline

Country Home Products, Inc.'s objective is to have 100% satisfied customers. For that reason, we operate a 6-day-a-week Technical Service Department for our Owners. You can access a Representative by dialing our TOLL-FREE Hotline at **1-800-DR-OWNER (376-9637)**. The sole job of our well-trained and friendly folks is to ensure that you get any help you need in a timely fashion. They are there to answer all your questions including: (1) inquiries on any of the above warranties, (2) inquiries about replacement parts, or (3) your questions regarding service, maintenance and operation.

Our Customer Service Representatives will also be happy to answer any of your questions regarding the separate warranties on all engines. However, to obtain service, repair or replacement of any engine within the time period covered by the manufacturer's limited warranty, follow the instructions and warranty information specifically pertaining to those items provided by their separate manufacturers.

THIS WARRANTY GIVES YOU SPECIFIC LEGAL RIGHTS, AND YOU ALSO HAVE OTHER RIGHTS, WHICH VARY FROM STATE TO STATE.

## **Daily Checklist for the DR LEAF and LAWN VACUUM**

To help maintain your DR LEAF and LAWN VACUUM for optimum performance, we recommend you follow this checklist each time you use your machine.

- [ ] OIL: With the machine on a level surface, remove the oil fill cap and check the oil level. Fill the reservoir according to the dipstick with SAE 30 HD motor oil. See page 25.
- [ ] GAS: Fill the gas tank with fresh, unleaded gasoline. See page 25.
- [ ] ENGINE: It is very important to keep the engine clean. Remove dirt and other debris from the engine cooling fins and debris guard. A dirty engine retains heat and can cause damage to internal engine components.
- [ ] HARDWARE: Check all nuts and bolts to be sure that the components are secure.
- [ ] FRAME: Check all welds to be sure that the frame is in tact and secure.
- [ ] BLOWER HOSES: Inspect the blower hoses for holes, frayed, worn, kinked, or abraded areas. Replace any damaged or worn hoses. See page 39.



COUNTRY HOME PRODUCTS, Inc.

---

**MEIGS ROAD, P.O. BOX 25, VERGENNES, VERMONT 05491**

1-800-DR-OWNER (376-9637) • [www.dr-owner.com](http://www.dr-owner.com)

©2005 CHP, Inc. 186971