

# TOW-BEHIND DR<sup>®</sup> FIELD and BRUSH MOWER

## SAFETY & OPERATING INSTRUCTIONS

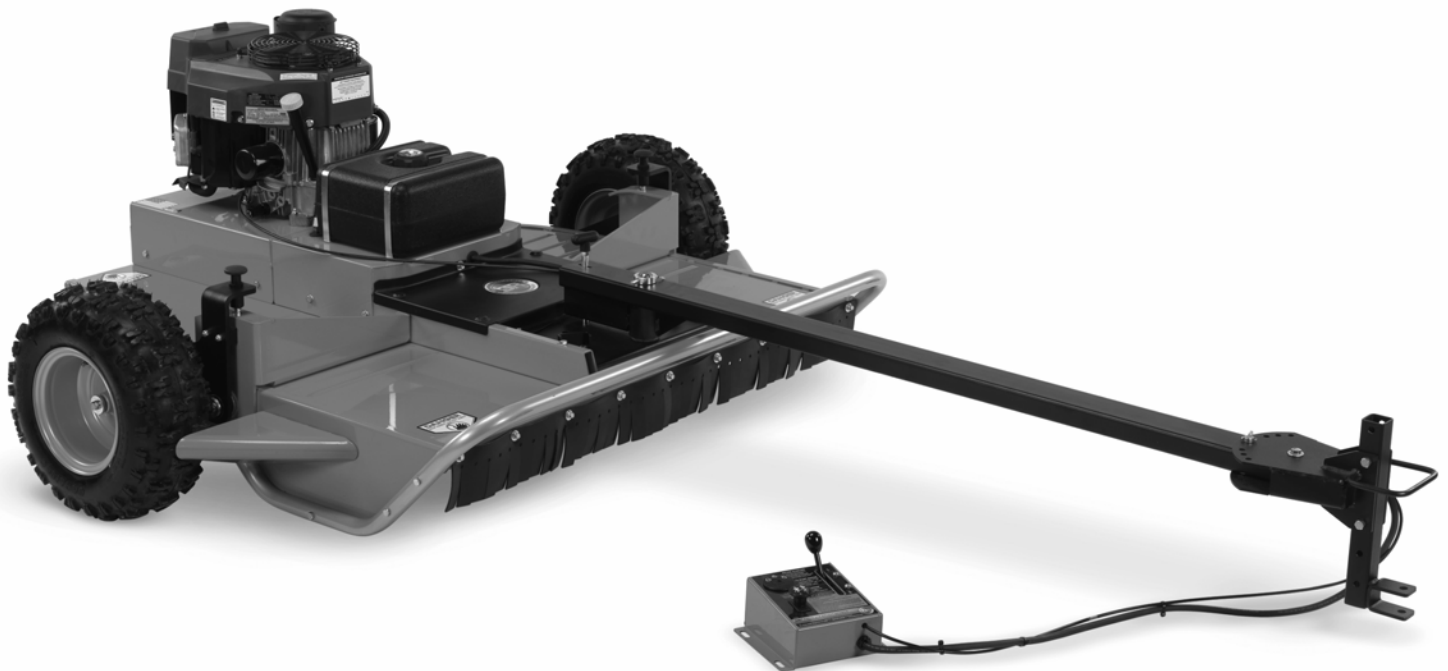

Serial No. \_\_\_\_\_

Order No. \_\_\_\_\_

DR Power Equipment  
Toll-free phone: 1-800-DR-OWNER (376-9637)  
Fax: 1-802-877-1213  
Website: [www.DRpower.com](http://www.DRpower.com)

### **WARNING!**

Read and understand this manual and all instructions before operating the TOW BEHIND DR FIELD and BRUSH MOWER.

# Table of Contents

Chapter 1: General Safety Rules..... 3  
Chapter 2: Setting Up The TOW-BEHIND DR FIELD and BRUSH MOWER..... 7  
Chapter 3: Operating The TOW-BEHIND DR FIELD and BRUSH MOWER..... 14  
Chapter 4: Maintaining The TOW-BEHIND DR FIELD and BRUSH MOWER ..... 19  
Chapter 5: Troubleshooting ..... 25  
Chapter 6: Parts Lists, Schematic Diagrams And Warranty ..... 27

## Conventions used in this manual

---

### **WARNING!**

This indicates a hazardous situation, which, if not avoided, *could* result in death or serious injury.

---

---

### **CAUTION!**

This indicates a hazardous situation, which, if not avoided, *could* result in minor or moderate injury.

---

---

### **NOTICE!**

This information is important in the proper use of your machine. Failure to follow this instruction could result in damage to your machine or property.

---

## Serial Number and Order Number

A Serial Number is used to identify your machine and is located on the Serial Number Label on your machine. An Order Number is used to check and maintain your order history and is located on the upper left portion of your packing slip. For your convenience and ready reference, enter the Serial Number and Order Number in the space provided on the front cover of this manual.

## Additional Information and Potential Changes

DR Power Equipment reserves the right to discontinue, change, and improve its products at any time without notice or obligation to the purchaser. The descriptions and specifications contained in this manual were in effect at printing. Equipment described within this manual may be optional. Some illustrations may not be applicable to your machine.

## Chapter 1: General Safety Rules

### **! WARNING!**

Read this safety & operating Instructions manual before you use the TOW BEHIND DR FIELD and BRUSH MOWER. Become familiar with the operation and service recommendations to ensure the best performance from your machine. If you have any questions or need assistance, please contact us at [www.DRpower.com](http://www.DRpower.com) or call toll-free 1-800-DR-OWNER (376-9637) and one of our Technical Support Representatives will be happy to help you.

### Labels

Your TOW BEHIND DR FIELD and BRUSH MOWER carries prominent labels as reminders for its proper and safe use. Shown below are copies of all the Safety and Information labels that appear on the equipment. Take a moment to study them and make a note of their location on your Mower as you set up and before you operate the unit. Replace damaged or missing safety and information labels immediately.

**WARNING: Check Oil  
Before Starting Engine**

#137581

**CAUTION:  
HOT SURFACE** →

#136831



#136491



#222221

### Protecting Yourself and Those Around You

### **! WARNING!**

This is a high-powered machine with fast moving parts operating at high speeds. You must operate this machine safely. Unsafe operation can create hazards for you, as well as anyone else in the work area. Use proper clothing and safety gear when operating this machine to prevent or minimize the risk of severe injury. Always take the following precautions when operating the TOW-BEHIND DR FIELD and BRUSH MOWER:

- Always wear protective goggles or safety glasses with side shields while mowing to protect your eyes from possible objects thrown from the machine.
- We recommend wearing safety shoes when using this machine. Wear shoes with non-slip treads to improve footing on slippery surfaces. Do not use the machine wearing open sandals or while barefoot.
- We recommend wearing long pants and gloves while using this machine. Be sure the gloves fit properly and do not have loose cuffs or drawstrings.
- We recommend the use of ear protectors or ear plugs rated for at least 20 dba to protect your hearing.
- Allow only responsible individuals who are familiar with these general safety rules and operating instructions to use your TOW-BEHIND DR FIELD and BRUSH MOWER. Never allow people who are unfamiliar with these rules and instructions to use your machine.
- Have a complete working knowledge of your tow vehicle and know how to handle it with the TOW-BEHIND DR FIELD and BRUSH MOWER attached.
- Keep your hands and feet away from the blades, belt, blade pulley, and concealed areas while the engine is running. Never reach under the deck or grab hold of any part of the deck when the engine is running.

---

**! WARNING!**

- The mower can throw objects far and at great speeds. Keep people and pets at least 100 feet away from your machine at all times. Install warnings around the area of operation stating “It is prohibited to enter this area”. Disengage the blade and stop the engine when a person or pet approaches within 100 feet. Do not restart the machine until people and pets are at least 100 feet away from the mower.
  - Clear the area of objects such as rocks, toys, wire, bones, sticks, etc., which could be picked up and thrown by the blades.
  - Be sure the blade control knob is down (disengaged) before attempting to start the engine.
  - Never get off the tow vehicle without first stopping the blades and shutting off the tow vehicle engine and the TOW-BEHIND DR FIELD and BRUSH MOWER engine.
  - Never, under any conditions, remove, bend, cut, fit, weld, or otherwise alter standard parts on the TOW-BEHIND DR FIELD and BRUSH MOWER. This includes all shields and guards. Modifications to your machine could cause personal injuries and property damage and will void your warranty.
- 

### *Safety for Children and Pets*

---

**! WARNING!**

Tragic accidents can occur if the operator is not alert to the presence of children and pets. Children are often attracted to the machine and the digging activity. *Never* assume that children will remain where you last saw them. Always follow these precautions:

- Keep children and pets at least 100 feet from the working area and ensure they are under the watchful care of a responsible adult.
  - Be alert and always turn off your tow vehicle engine and the Tow-Behind DR Field & Brush Mower engine if children enter the work area.
  - Before, and while moving your tow vehicle backwards, look behind, and down for small children.
  - Never allow children to operate the TOW-BEHIND DR FIELD and BRUSH MOWER.
  - Never allow children to ride on the mower, even if the engine is not running.
  - Use extra care when approaching blind corners, shrubs, trees, or other objects that may obscure your vision.
- 

### *Slope Operation*

---

**! WARNING!**

Use of machinery on slopes is a major factor related to accidents, which can result in severe personal injury. Use of machinery on slopes requires caution. If you feel uneasy using the TOW-BEHIND DR FIELD and BRUSH MOWER on a slope, do not operate it. Always take the following precautions when using this machine on slopes:

ALWAYS:

- Operate the machine up and down the face of slopes and avoid going across. Exercise extreme caution when changing direction on slopes.
- Remove objects such as glass, large sticks, stones, metal objects, wire, rope, and string-like material.
- Watch for holes, ruts, and bumps on the ground.

NEVER:

- Never operate near drop-offs, ditches, or embankments; you could lose control of your tow vehicle and/or the TOW-BEHIND DR FIELD and BRUSH MOWER.
  - Never operate on slopes greater than 20 degrees, or on any excessively steep slope. See the operating parameters section on page 21 for further restrictions relating to your tow vehicle.
  - Never operate on wet, or slippery slopes. Reduced traction could result in tipping over your tow vehicle and/or the TOW-BEHIND DR FIELD and BRUSH MOWER.
  - Never park the tow vehicle on a steep grade or slope.
-

## ***Safety with Gasoline - Powered Machines***

---

### **WARNING!**

Gasoline is a highly flammable liquid. Gasoline also gives off flammable vapor that can be easily ignited and cause a fire or explosion. Never overlook the hazards of gasoline. Always follow these precautions:

- Never run the engine in an enclosed area or without proper ventilation as the exhaust from the engine contains carbon monoxide, which is an odorless, tasteless, and deadly poisonous gas.
  - Store all fuel and oil in containers specifically designed and approved for this purpose and keep away from heat and open flame, and out of the reach of children.
  - Replace rubber fuel lines and grommets when worn or damaged and after 5 years of use.
  - Fill the gasoline tank outdoors with the engine off and allow the engine to cool completely. Don't handle gasoline if you or anyone nearby is smoking, or if you're near anything that could cause it to ignite or explode. Reinstall the fuel tank Cap and fuel container cap securely.
  - If you spill gasoline, do not attempt to start the engine. Move the machine away from the area of the spill and avoid creating any source of ignition until the gas vapors have dissipated. Wipe up any spilled fuel to prevent a fire hazard and properly dispose of the waste.
  - Allow the engine to cool completely before storing in any enclosure. Never store a machine that has gas in the tank, or a fuel container, near an open flame or spark such as a water heater, space heater, clothes dryer or furnace.
  - Never make adjustments or repairs with the engine running. Shut down the engine, disconnect the spark plug wire, keeping it away from the spark plug to prevent accidental starting, wait 5 minutes before making adjustments or repairs.
  - Never check for an ignition spark with the spark plug or spark plug wire(s) removed. Always use an approved spark tester.
  - Never tamper with safety devices. Regularly check their proper operation.
  - Never change the engine governor settings or modify the engine speed. Modifications will void your warranty.
  - To reduce fire hazard, keep the engine and muffler area free of debris build-up such as leaves, grass, oil, grease, or any other combustible material. Clean the engine area after each use.
  - Never operate the engine without the muffler. Inspect the muffler periodically and replace if necessary. If the engine is equipped with a muffler deflector, inspect it periodically and replace if necessary.
  - Never cover the machine while the muffler is still hot.
  - Do not operate the engine with the air cleaner or the carburetor air intake cover removed. Removal of such parts could create a fire hazard. Do not use flammable solutions to clean the air filter.
  - The muffler and engine become very hot and can cause a severe burn; do not touch.
-

## General Safety

---

### **WARNING!**

Safe operation of the TOW-BEHIND DR FIELD and BRUSH MOWER is necessary to prevent or minimize the risk of death or serious injury. Unsafe operation can create a number of hazards for you. Always take the following precautions when operating this machine:

- The TOW-BEHIND DR FIELD and BRUSH MOWER is a powerful tool and not a plaything. When using this machine, exercise extreme caution at all times. The design of this machine is to mow grass and brush. Do not use it for any other purpose.
  - The operator or user of the TOW-BEHIND DR FIELD and BRUSH MOWER is responsible for accidents or hazards occurring to other people, their property, and themselves.
  - Always mount the remote control panel within easy reach of the operator's position.
  - Know how to quickly stop the TOW-BEHIND DR FIELD and BRUSH MOWER. See page 15.
  - Never allow people or pets to ride on this machine, even with the engine turned off.
  - If the machine should make an unusual noise or vibration, shut off the tow vehicle and the TOW-BEHIND DR FIELD and BRUSH MOWER engines. Vibration is generally a warning of trouble. Wait five (5) minutes for the TOW-BEHIND DR FIELD and BRUSH MOWER engine to cool. Disconnect the spark plug wire(s) and then inspect the machine for clogging, or loose engine mounting bolts. Clear any obstructions and repair and/or replace damaged parts.
  - The mower blades are sharp and can cut. Wrap the blades or wear gloves, and use extra caution when servicing.
  - Always keep the machine in good safe operating condition. Always make certain nuts and bolts are tight and always use the supplied self-locking hardware. Do not use substitute hardware.
  - Always shut off the tow vehicle engine TOW-BEHIND DR FIELD and BRUSH MOWER engine, wait five (5) minutes to cool, and disconnect the spark plug wire(s) before attempting to remove grass or debris from the underside of the deck.
  - Use the TOW-BEHIND DR FIELD and BRUSH MOWER only in daylight and give complete and undivided attention to the job at hand.
  - Do not hurry or take things for granted when using the TOW-BEHIND DR FIELD and BRUSH MOWER. When in doubt about the machine or your surroundings, stop the mowing activity and take time to look things over.
  - Disengage the blades and exercise extreme caution when on or crossing drives, walks, or roads. Stay alert for hidden hazards or traffic.
  - If leaving the machine, shift the tow vehicle into neutral and set the parking brake; turn off the tow vehicle engine and remove its key; turn off the TOW-BEHIND DR FIELD and BRUSH MOWER engine and remove its key.
- 

### **A Note to All Users**

Under California law, and the laws of some other states, you are not permitted to operate an internal combustion engine using hydrocarbon fuels without an engine spark arrester. This also applies to operation on US Forest Lands. All TOW-BEHIND DR<sup>®</sup> FIELD and BRUSH MOWERS shipped to California, New Mexico and Washington State are provided with spark arresters. Failure of the owner or operator to maintain this equipment in compliance with state regulations is a misdemeanor under California law and may be in violation of other state and/or federal regulations. Contact your State Park Association or the appropriate state organization for specific information in your area.

No list of warnings and cautions can be all-inclusive. If situations occur that are not covered by this manual, the operator must apply common sense and operate this TOW-BEHIND DR FIELD and BRUSH MOWER in a safe manner. Contact us at [www.DRpower.com](http://www.DRpower.com) or call 1-800-DR-OWNER (376-9637) for assistance.

## Chapter 2: Setting Up The TOW-BEHIND DR FIELD and BRUSH MOWER

It may be helpful to familiarize yourself with the controls and features of your TOW-BEHIND DR FIELD and BRUSH MOWER by reviewing **Figure 1** before beginning these procedures. If you have any questions at all, please feel free to contact us at [www.DRpower.com](http://www.DRpower.com).

### **TOW-BEHIND DR FIELD and BRUSH MOWER Controls and Features**

**NOTE:** The model shown in Figure 1 may look slightly different from your machine.

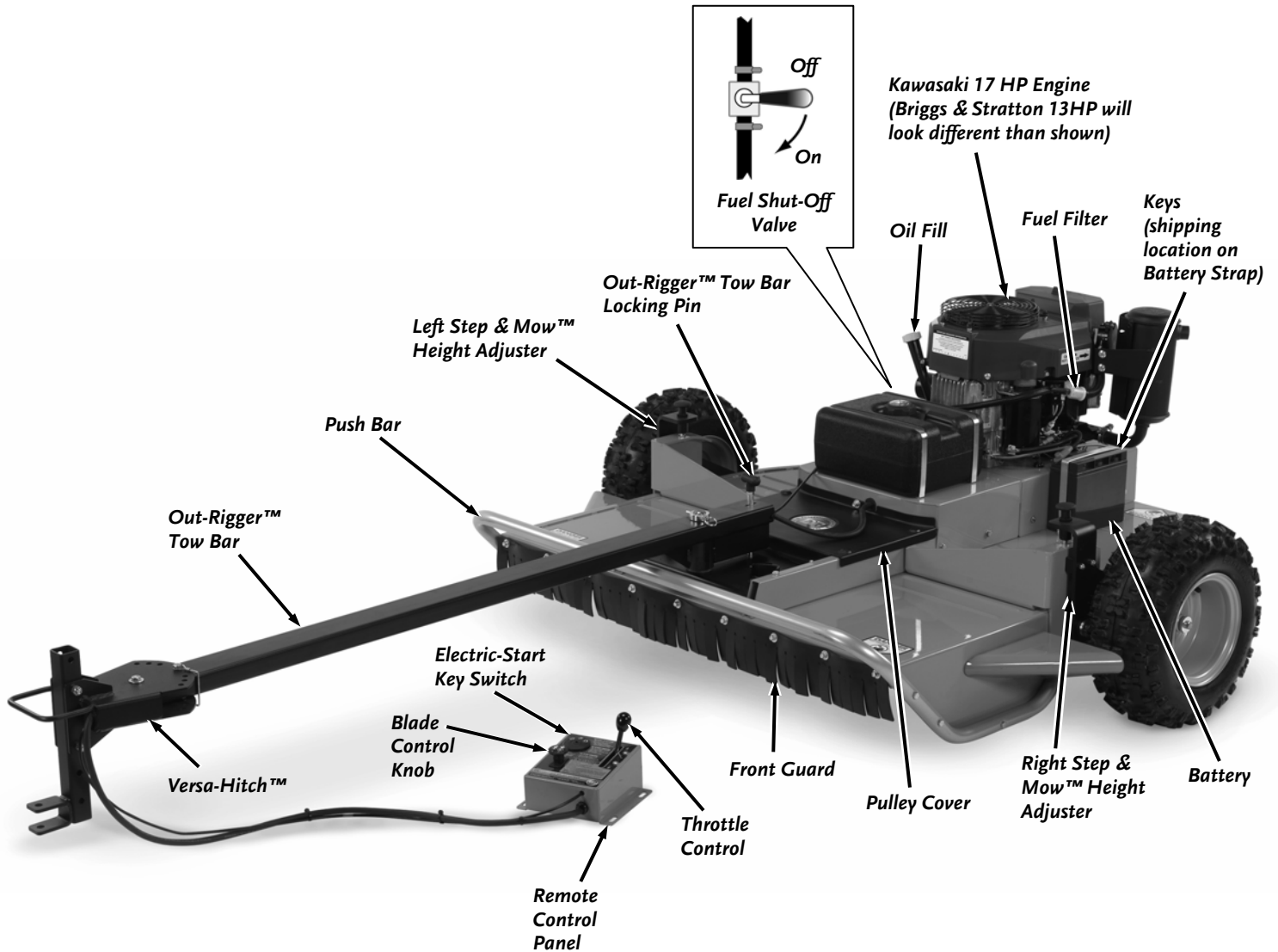

Figure 1

## Specifications

	<b>13 HP Pro Model</b>	<b>17 HP Commercial Model</b>
<b>Machine Warranty</b>	2 year Residential, 90 day Commercial	2 year Residential, 90 day Commercial
<b>Engine Warranty</b>	2 year Residential, 1 year Commercial	2 year Residential, 2 year Commercial
<b>Engine</b>	13 HP Briggs & Stratton Engine, Electric Start, OHV, 1 Cast-Iron Sleeve, Full Pressure Oil Pump w/ Oil Filter, 48 oz Oil Capacity, Dual-Element Air Filter, Fuel Pump, Electronic Ignition	17 HP Kawasaki KAI Engine, Electric Start, V-Twin OHV, 2 Cast-Iron Sleeves, Full Pressure Oil Pump w/ Oil Filter, 58 oz Oil Capacity, Dual-Element Air Filter, Fuel Pump, Electronic Ignition
<b>Fuel Tank</b>	2.5 Gallons, Gasoline, Unleaded	2.5 Gallons, Gasoline, Unleaded
<b>Wheels</b>	18" Dia. x 6-7/8" Wide, All Terrain Tread, 28 PSI, Sealed, Tubeless	18" Dia. x 6-7/8" Wide, All Terrain Tread, 28 PSI, Sealed, Tubeless
<b>Remote Control Panel</b>	Key Switch, Throttle Lever, and Blade Engage Switch, 5' from Versa-Hitch™ to front of Control Panel.	Key Switch, Throttle Lever, and Blade Engage Switch, 5' from Versa-Hitch™ to front of Control Panel.
<b>Deck Offset</b>	0%, 50%, 75%, 100% Out-Rigger™ Tow Bar	0%, 50%, 75%, 100% Out-Rigger™ Tow Bar
<b>Adjustable Cutting Height</b>	5", 6-1/4", and 7-1/2" Step & Mow™ Wheel Axle and Versa-Hitch™	5", 6-1/4", and 7-1/2" Step & Mow™ Wheel Axle and Versa-Hitch™
<b>Cutting Width</b>	44"	44"
<b>Cutting Capacity</b>	4' High Grass, 1-1/2" Thick Saplings	6' High Grass, 1-1/2" Thick Saplings
<b>Blade Tip Speed</b>	195 MPH or 17,180 Ft/Min	195 MPH or 17,180 Ft/Min
<b>Swinging Blades</b>	"PRO-TEK" Swinging Blades 2 Blades, .25" Thick x 16-1/2" Long Hardened Steel	"PRO-TEK" Swinging Blades 2 Blades, .25" Thick x 16-1/2" Long Hardened Steel
<b>Deck</b>	11 GA (.12" thick) Welded Steel	11 GA (.12" thick) Welded Steel
<b>Spindle</b>	1-3/8" Dia. Shaft with 2 Sealed 30 mm Bearings	1-3/8" Dia. Shaft with 2 Sealed 30 mm Bearings
<b>Spindle Housing</b>	7 GA (.18" thick) Welded Steel	7 GA (.18" thick) Welded Steel
<b>Push Bar</b>	1-1/4" Dia. x 11 GA (.12" thick) Steel Tubing	1-1/4" Dia. x 11 GA (.12" thick) Steel Tubing
<b>Front Guard</b>	3/16" Thick Compressed Rubber	3/16" Thick Compressed Rubber
<b>Belt</b>	5/8" x 53.8" Type BP51	5/8" x 53.8" Type BP51
<b>Electric Clutch</b>	75 ft-lb Ogura	75 ft-lb Ogura
<b>Fuses</b>	20 AMP Type AGC Fuse (Engine Alternator Circuit) 7 AMP Type AGC Fuse (Clutch Circuit)	20 AMP Type AGC Fuse (Engine Alternator Circuit) 7 AMP Type AGC Fuse (Clutch Circuit)
<b>Machine Overall Width</b>	64-1/4" Outside the Wheels	64-1/4" Outside the Wheels
<b>Machine Overall Length</b>	110" with the Tow Bar fully extended	110" with the Tow Bar fully extended
<b>Machine Overall Height</b>	28-1/4"	28-7/8"
<b>Machine Weight at Tow Bar</b>	35 lbs.	27 lbs.
<b>Machine Weight</b>	442 lbs.	465 lbs.
<b>Shipping Weight</b>	617 lbs.	641 lbs.
<b>Shipping Crate</b>	73" x 60" x 36"	73" x 60" x 36"

## Unpacking and Assembling the Machine

Unpacking and assembling the TOW-BEHIND DR FIELD and BRUSH MOWER is a two-person job as the 13 HP unit weighs 442 pounds and the 17 HP unit weighs 465 pounds. We recommend you have an extra set of hands available before you begin. Electric Start models have the Key located on the rear of the Battery Strap as shown in Figure 1 on page 7.

### Parts Supplied in Crate:

- TOW-BEHIND DR FIELD and BRUSH MOWER
- Safety & Operating Instructions Manual
- Briggs & Stratton or Kawasaki Engine Manual
- Small Parts Bag:
  - Hook and Loop Straps
  - Plastic hose (oil drain)
  - Extra Zip-Tie Wraps



### Tools and Supplies Needed:

- Pry Bar
- Metal Shears
- Hammer
- Gloves and Eye Protection

---

### CAUTION!

- Stabilize the shipping container on clean flat terrain before attempting to unpack and assemble the machine.
- Always wear eye protection and stand to one side when cutting the banding. The banding is under a lot of tension and can cause injury when you release the tension.
- Use caution around exposed nails when uncrating the machine.

- 
1. Pry off and remove the top cross members of the shipping crate. **Be careful of the nails when removing the boards.**
  2. Pry off and remove the crate sides; the two (2) long sides first, and then the two (2) short sides.
  3. Stand to one side and cut any bands holding the machine to the shipping pallet and the bands holding the Remote Control Panel carton to the Push Bar. **Be careful when cutting the banding.**

---

### CAUTION!

Wear gloves and be very careful when handling the deck. The blades are very sharp, and may spin as you maneuver the deck.

- 
4. The Out-Rigger™ Tow Bar shipped unassembled; remove it from the pallet.
  5. Raise the Mower Deck Height to the highest setting (7-1/2") to clear the blocking beneath the back of the machine (see page 24) and then roll the Mower off the shipping pallet.
  6. Remove the Blade Protector from the Blades. (See **CAUTION** note above)
  7. Do not discard your pallet and packaging material until you are fully satisfied with your new TOW-BEHIND DR FIELD and BRUSH MOWER.

### ***About the Battery***

The TOW-BEHIND DR FIELD and BRUSH MOWERS come with a 12-Volt, maintenance-free, rechargeable, sealed lead acid Battery. Properly maintained and charged, the Battery provides years of dependable service.

---

### WARNING!

- Never modify the TOW-BEHIND DR FIELD and BRUSH MOWER'S electrical system. Modifications could ruin the electrical system as well as cause a fire, resulting in serious injury.
- Using electrical components other than those supplied with your machine could cause the electrical system to overheat, explode, or start a fire.
- Using the wrong type of battery or charger could cause a fire or explosion, resulting in serious injury.
- Use the charger only in dry locations. Avoid contact with water.
- Only adults should handle the battery. It contains sulfuric acid (an electrolyte) and the battery is heavy; dropping it could result in serious injury.
- Never allow children to charge the battery. **THE ELECTRICITY INVOLVED IN CHARGING THE BATTERY COULD CAUSE SEVERE INJURY.**
- Examine the charger, its connectors, and the battery for excessive wear or damage each time you charge the battery. Replace any components showing excessive wear or damage.
- Never lift or carry the battery by the cables or terminals. This can damage the battery and possibly start a fire, resulting in serious injury. Lift and carry the battery only by its case.
- Do not short circuit the battery.
- Read the safety instructions on the battery.

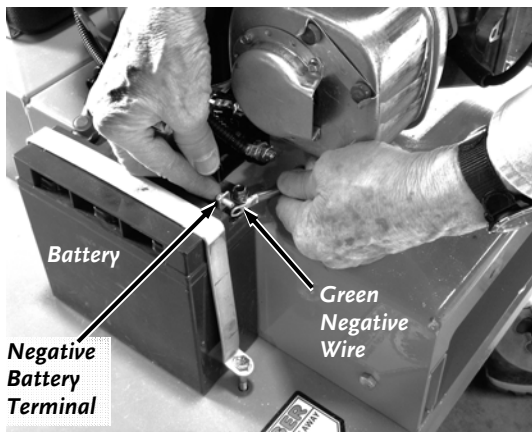

Figure 2

## Connecting the Battery Wire

We ship all Electric-Starting systems with the negative terminal Battery wire disconnected. This prevents the Battery from discharging during shipment. Before using your TOW-BEHIND DR FIELD and BRUSH MOWER, you must connect the Battery wire.

### Tools Needed:

- Two 5/16" Wrenches

1. Connect the Green negative wire to the negative terminal on the Battery with two 5/16" Wrenches (**Figure 2**).

**NOTE:** The Bolt and Nut come with the Battery.

## Adding Oil and Gasoline

### ! NOTICE!

- You must add oil before starting the engine. This machine is shipped without oil. Traces of oil may be in the reservoir from factory testing, but **YOU MUST ADD OIL BEFORE STARTING THE ENGINE**. Fill the reservoir slowly, checking the level frequently to avoid overfilling.
- To get an accurate reading when checking the oil level:
  - the machine should be on a level surface.
  - the dipstick **SHOULD** be screwed down on 13 HP Briggs and Stratton engines.
  - the dipstick **SHOULD NOT** be screwed down on 17 HP Kawasaki engines.

**Tip:** To avoid confusion, we recommend leaving the caps ON the Fuel and Oil Fills until you are ready to pour either gasoline or oil into the correct Fill.

**NOTE:** Use only SAE 30 HD (High Detergent) oil. Other types of oil could cause problems with the operation of your machine. Please refer to your Engine Owner's Manual for detailed oil information.

Engine Oil and Fuel Capacities		
	Oil (SAE 30 HD)	Fuel (Unleaded)
Briggs & Stratton - 13 HP	48 oz. (1.4 L)	2.5 Gal (9.5 L)
Kawasaki - 17 HP	58 oz. (1.7 L)	2.5 Gal (9.5 L)

1. Place the machine on a level surface and initially add 32 oz. of SAE 30 High Detergent oil (recommended by the Engine Manufacturer) into the Oil Fill (**Figure 3**) and wait one minute for the oil to settle.

2. Check the Dipstick and continue adding a few ounces of oil at a time, rechecking the Dipstick until the oil reaches the fill mark. Be careful not to overfill.
3. Fill the gas tank to within 1-1/2 inches below top of fill neck (to allow for fuel expansion) with fresh, unleaded gas. See the Engine Owner's Manual for more information.

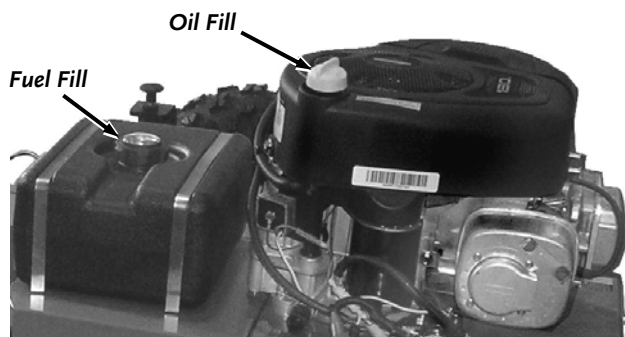

Briggs & Stratton 13 HP Engine

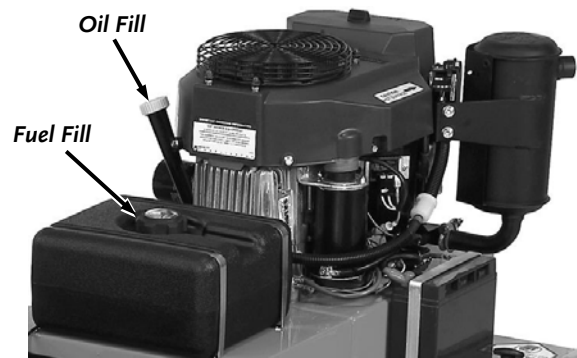

Kawasaki 17 HP Engine

Figure 3

## Attaching the Out-Rigger™ Tow Bar to the TOW-BEHIND DR FIELD and BRUSH MOWER

### **WARNING!**

When attaching the tow bar and wire harnesses, you must first disconnect the spark plug wire(s), keeping it away from the spark plug(s) to prevent accidental starting of the engine.

#### Tools Needed:

- 7/16" Wrench or Socket

1. Using a 7/16" Wrench or Socket, remove the three (3) Bolts and Washers that retain the black Pulley Cover and remove the Cover (**Figure 4**).
2. Locate and remove the Tow Bar Retaining Pin and Collar from the Pivot Pin on the front of the Mower Deck.
3. Pull the Handle of the Tow Bar Locking Pin up so its Cross Pins are above the Tow Bar and then twist the Handle 90° so the bottom Cross Pin rests on top of the Tow Bar (**Figure 5**).

**Tip:** Enlist the help of another person to hold the Tow Bar level during the next step.

4. Place the Tow Bar over the Pivot Pin and install the Collar and the Tow Bar Retaining Pin.

**NOTE:** The Remote Control Panel Throttle Cable and Wire Harness are routed inside the Tow Bar housing. Use care not to pinch them when attaching the Tow Bar over the Pivot Pin.

5. Pull the Tow Bar Locking Pin Handle up, turn it 90°, and release the Locking Pin into the center hole in the Tow Bar Mount Plate.

### Connecting the Remote Control Panel Throttle Cable and Control Wire Harness

**NOTE:** An optional Control Extension Kit is available to give you more mounting options for your machine. You can replace the existing Throttle Cable with a longer one and extend the existing Wire Harness. Visit our website at [www.DRpower.com](http://www.DRpower.com) to order Kit #233881 for the Briggs and Stratton Engine or Kit #233901 for the Kawasaki Engine.

#### Control Wire Harness

1. Locate the Solenoid Wire Harness with Terminals under the orange Fuel Tank Mount (**Figure 6**).
2. Connect the terminals of the Solenoid Wire Harness to the terminals of the Control Wire Harness coming from the Tow Bar (they are keyed and color coded) by pushing them together until they snap in place.
3. Position the Strain-Relief behind the cutout in the Fuel Tank Mount and then pull it towards you into the cutout until it snaps in place. Make sure the Wire Harness terminals are tucked back under the Fuel Tank Mount.
4. Replace the black Belt Cover and secure with the three Bolts and Washers.

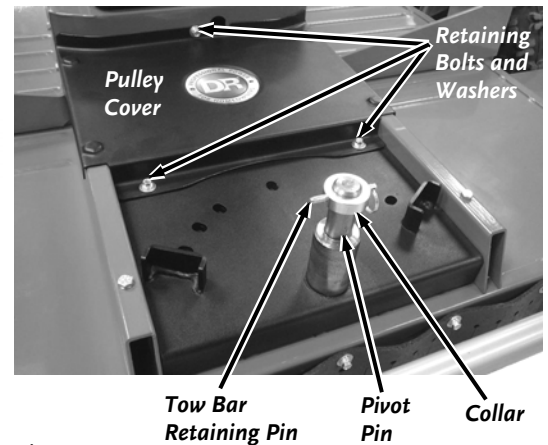

Figure 4

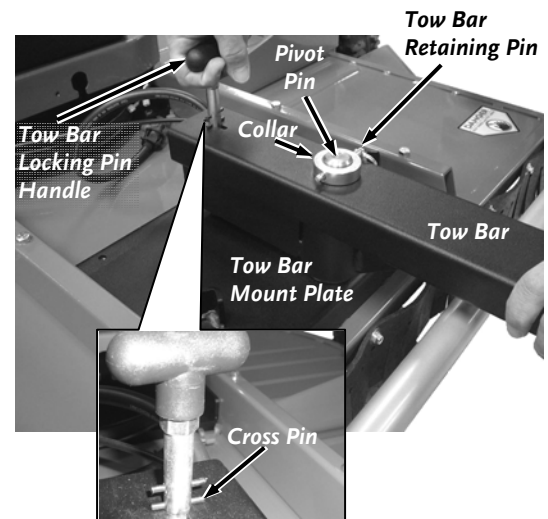

Figure 5

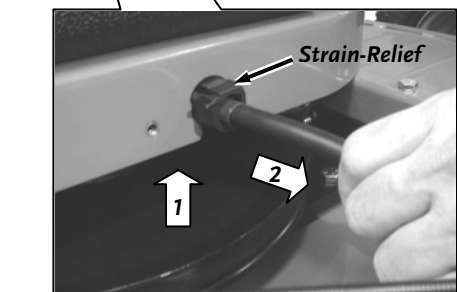
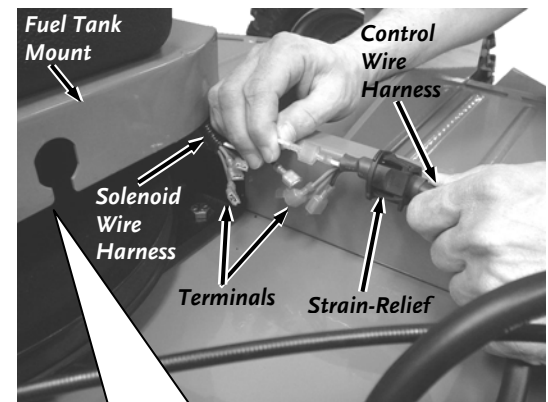

Figure 6

CONTACT US AT [www.DRpower.com](http://www.DRpower.com)

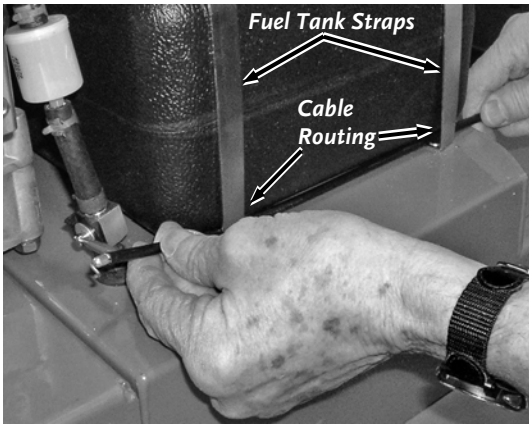

Figure 7

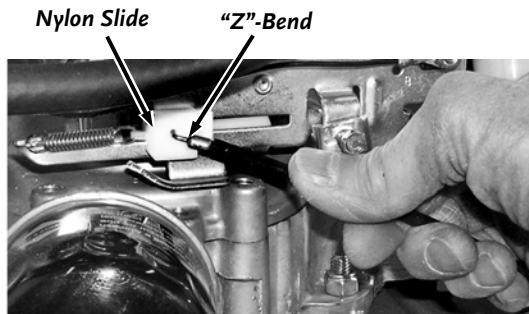

Figure 8

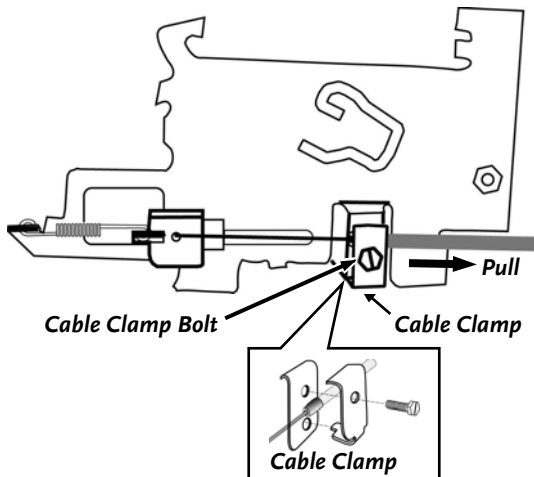

Figure 9

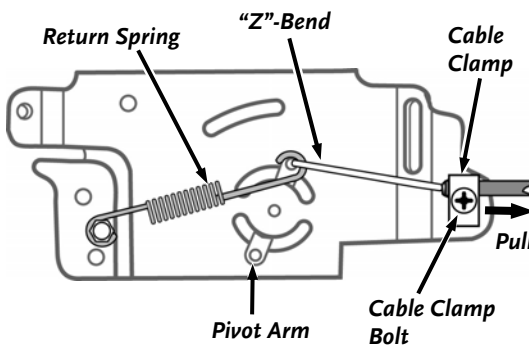

Figure 10

## Throttle Cable - 13 HP B&S

### Tools Needed:

- Blade Screwdriver or 5/16" Nut Driver

1. Route the Throttle Cable from the Tow Bar behind the Fuel Tank straps (**Figure 7**).
2. Move the Throttle Control to the Choke position on the Remote Control Panel.
3. Insert the "Z"-Bend of the Cable end into the hole in the Nylon Slide on the side of the carburetor (**Figure 8**).
4. Using a Blade Screwdriver or 5/16" Nut Driver, loosen the Throttle Cable Clamp Bolt (**Figure 9**) and slip the Cable Sheath behind the Clamp.
5. Pull the Cable as far as possible. This will move the Engine mechanism into the Choke position.
6. Tighten the Cable Clamp Bolt while holding the Cable in the Choke position.

## Throttle Cable - 17 HP Kawasaki

### Tools Needed:

- Phillips Screwdriver, or Blade Screwdriver, or 5/16" Nut Driver

1. Route the Throttle Control Cable from the Tow Bar behind the Fuel Tank straps (**Figure 7** on page 17).
2. Move the Throttle Control to the Choke position on the Remote Control Panel.
3. Loop the end of the Return Spring over the "Z"-Bend of the Throttle Cable (**Figure 10**).
4. Insert the "Z"-Bend of the Cable end into the top hole in the Throttle Pivot Arm on the side of the carburetor.
5. Using a Screwdriver or Nut Driver, loosen the Throttle Cable Clamp Bolt, and slip the Cable Sheath behind the Clamp.
6. Pull the Cable as far as possible. This will move the Pivot Arm into the Choke position.
7. Tighten the Cable Clamp Bolt while holding the Cable in the Choke position.

## Connecting the TOW-BEHIND DR FIELD and BRUSH MOWER to your Tow Vehicle

The Versa-Hitch™ on the TOW-BEHIND DR FIELD and BRUSH MOWER Out-Rigger™ Tow Bar has four positions to accommodate different Tow Vehicle hitch heights. The Versa-Hitch™ positions are also for leveling the machine according to the Cutting Height setting of the machine. See page 16.

1. Move your Tow Vehicle to a reasonably flat area and set the Parking Brake. Lift the Versa-Hitch™ and position it onto the center of the Tow Vehicle Hitch Plate and secure with the Clevis Pin and Hitch Clip Pin (Figure 11).

## Attaching the TOW-BEHIND DR FIELD and BRUSH MOWER

### ! NOTICE!

For the machine to work properly, It is important to use the Versa-Hitch™ height setting that positions the Out-Rigger™ Tow Bar level with the ground.

## Remote Control Panel

1. Locate the Remote Control Panel (Figure 12) on your Tow Vehicle within reach of the seated Tow Vehicle driver.
2. Secure the Remote Control Panel by threading the Hook and Loop Straps provided with your TOW-BEHIND DR FIELD and BRUSH MOWER, through the Remote Control Panel Mounting Slots and then around a fixed object on

### ! NOTICE!

Be sure to route the Throttle Cable and Control Wire Harness between the Hitch and the Remote Control Panel away from the muffler of the tow vehicle.

your Tow Vehicle (Figure 13a and b).

## Checking the Tire Pressure

The maximum Tire pressure is marked on the side of each Tire. Do not exceed the manufacturer's recommended maximum pressure.

**NOTE:** They are Self-sealing Tubeless Tires to protect against minor punctures.



Mower Mounted

Figure 13b

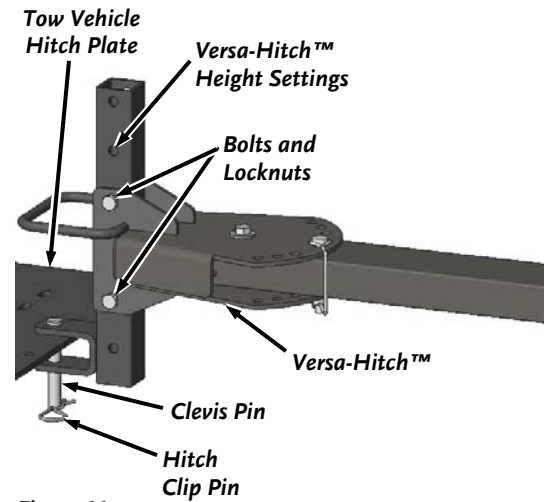

Figure 11

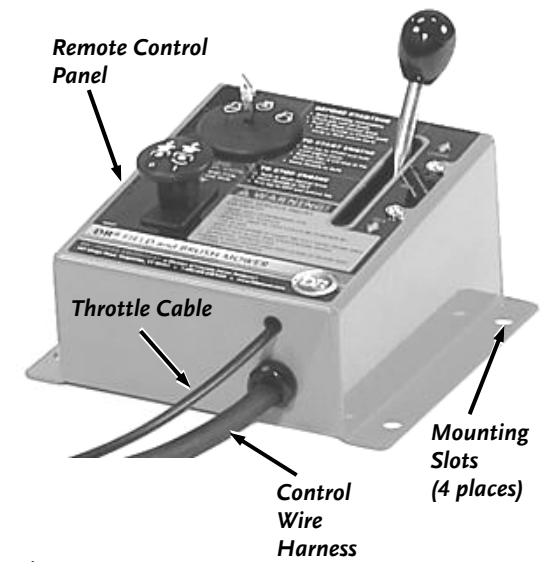

Figure 12

Mounted Remote Control Panel



ATV Mounted

Figure 13a

## Chapter 3: Operating The TOW-BEHIND DR FIELD and BRUSH MOWER

---

This chapter covers the procedures for starting and stopping your new TOW-BEHIND DR FIELD and BRUSH MOWER and discusses basic operation features. You may find it helpful to review the TOW-BEHIND DR FIELD and BRUSH MOWER Controls and Features on page 7 before reading this chapter.

### **WARNING!**

- This machine is designed for cutting grass and brush. Never use this machine for any other purpose as it could cause serious injury.
  - Contact with internal rotating parts will cause serious personal injury. Never put hands, face, feet, or clothing under the deck or near the discharge area with the engine running.
  - Before performing any maintenance procedure or inspection, stop the engine and wait five (5) minutes to allow all parts to stop and cool. Disconnect the spark plug wire(s) keeping it away from the spark plug(s).
- 

### **Operating Parameters**

We recommend a few types of Tow Vehicles for the TOW-BEHIND DR FIELD and BRUSH MOWER. The Tow Vehicle may be either 2 or 4 wheel drive, but some vehicle types are not suitable for rough hilly terrain or heavy brush conditions. See the Tow Vehicle Restrictions section below.

- ATV
- Lawn/Garden Tractor (17 HP and above and weighing at least 500 pounds)
- Riding Lawn Mower (14 HP and above and weighing at least 400 pounds)
- Utility Vehicle
- Compact or Sub-Compact Tractor

### **Tow Vehicle Restrictions:**

- You must be able to secure the Remote Control Panel of the TOW-BEHIND DR FIELD and BRUSH MOWER within easy reach of the driver seated on the Tow Vehicle. The front of the Control Panel is 5' from the Versa-Hitch™. A Utility Vehicle with a bed longer than 2 ft. will not meet this restriction so you cannot use it as a Tow Vehicle.
- Riding Lawn Mowers with Engines under 17 HP and weighing less than 500 pounds are not suitable for use on slopes greater than 5°.
- Never operate your TOW-BEHIND DR FIELD and BRUSH MOWER on slopes greater than 20° using any type of Tow Vehicle.
- If your Tow Vehicle will not travel by itself over the terrain you plan to use it with the TOW-BEHIND DR FIELD and BRUSH MOWER, then it will not be suitable as a Tow Vehicle over that terrain.

**Tip:** Riding Lawn Mowers will work best as a Tow Vehicle with their cutting deck removed.

### **CAUTION!**

- We do not recommend driving over 5 mph on flat terrain and over 4 mph on rough terrain while operating your TOW-BEHIND DR FIELD and BRUSH MOWER.
  - Never use a truck (2 or 4wd) or jeep to operate the TOW-BEHIND DR FIELD and BRUSH MOWER. It would be difficult to see and you cannot operate the mower controls from these types of tow vehicles. Using these vehicles will void the TOW-BEHIND DR FIELD and BRUSH MOWER warranty.
-

## Before Starting the Engine



Inspect the area where you will be working. The site must be free of potentially hazardous obstacles such as glass, large stones, sticks, wire, rope, and string-like materials. Make sure there are no people or animals in the area around the TOW-BEHIND DR FIELD and BRUSH MOWER.

---

1. Check the oil level every time you use the machine (*Figure 3 on page 10*).
2. Check the gasoline level (*Figure 3 on page 10*).
3. Open the Fuel Shut-Off Valve, which is located in the Fuel Line (*Figure 1 on page 7*).
4. Make sure the Blade Control Knob is pushed down to the disengaged position (*Figure 1 on page 7*).

**NOTE:** The Blade Control Knob must be DOWN, or the Engine will not start.

## Starting

1. Push the Blade Control Knob down to disengage the Blades (*Figure 1 on page 7*).
2. When starting a cold Engine, push the Throttle Control Lever up to the CHOKE position. When starting an already warm Engine, push the Throttle Control Lever down to the RUN position (*Figure 1 on page 7*).
3. Turn the Key Switch to the center position (ON), and then to the START position (*Figure 1 on page 7*) until the Engine starts, then release. The Key will snap back to the center position (ON) and the Engine will continue to run.
4. As the Engine warms up, slowly adjust the Throttle to the Run position. Wait until the Engine runs smoothly before each Throttle adjustment. For maximum performance, operate the Engine with the Throttle in the RUN position.

## Stopping the Engine

1. Disengage the Blades by pushing the Blade Control Knob down.
2. Move the Throttle Control Lever all the way down to the IDLE position and turn the Key to STOP.
3. Remove the Key for safety. The Key has a pressure lock that prevents it from vibrating loose during operation. To remove the Key, push it in and then quickly and firmly pull it out. If the Key becomes difficult to remove, apply a non-conductive lubricant into the Keyhole.

**NOTE:** Close the Fuel Shut-Off Valve when transporting or storing the TOW-BEHIND DR FIELD and BRUSH MOWER.



Never stop the engine by moving the throttle control lever to the choke position. This could cause an engine backfire resulting in engine damage.

---

## Engaging the Blades

1. Engage the Blades by pulling UP on the Blade Control Knob (*Figure 1 on page 7*).

## Stopping the Blades

1. Push DOWN on the Blade Control Knob (*Figure 1 on page 7*).

## Adjusting the Mower Deck Height

### **! WARNING!**

- Shut off the engine before adjusting the deck height or serious injury may result. The blades could sever your foot if it sticks under the deck with the engine running.
- Never get off the tow vehicle without first stopping the blades and shutting off the tow vehicle engine and the TOW-BEHIND DR FIELD and BRUSH MOWER engine.

**NOTE:** The TOW-BEHIND DR FIELD and BRUSH MOWER Deck has four (4) cutting heights, 4", 5-1/4", 6-1/2" and 7-3/4".

### **! CAUTION!**

Keep your foot clear of the mower deck when adjusting the height. You could pinch your foot if it sticks under the deck.

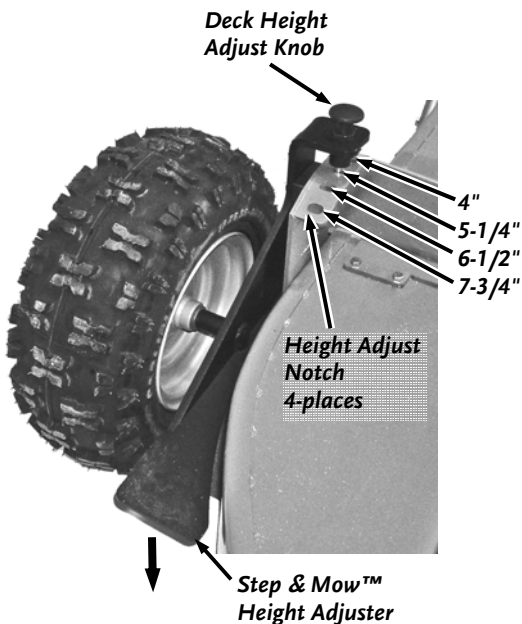

Figure 14

1. To change the cutting height, apply foot pressure to the Step & Mow™ Height Adjuster (**Figure 14**) and at the same time, lift up on the spring loaded Deck Height Adjust Knob and re-position the Knob to the desired height in one of the four Height Adjust Notches on top of the Deck. Repeat this for the opposite side of the Deck.

**NOTE:** Make sure that the left and right side Adjust Knob is the same notch for both sides.

**Tip:** Since you previously leveled the Out-Rigger™ Tow Bar when attaching it to your Tow Vehicle, whenever you change Cutting Height position up or down, just move the Versa-Hitch™ (**Figure 11 on page 13**) up or down to ensure that the Tow Bar is level or slightly lower at the Tow Hitch.



## Offset Mowing

The Out-Rigger™ Tow Bar allows you to offset the cutting path of the TOW-BEHIND DR FIELD and BRUSH MOWER up to 100% from the Tow Vehicle. The provided locking positions are 0%, 50%, 75%, and 100%. Offset mowing allows you to mow closer to equipment, trees, and fences and to drive in area already cut.

### **CAUTION!**

When performing offset mowing, always be sure that the Out-Rigger™ Tow Bar angle setting (**Figure 15**) and the Versa-Hitch™ angle setting match. This allows the tow-behind DR field and brush mower to track parallel to the tow vehicle.

#### **Offset at the Tow Bar Mount Plate:**

1. Lift the Handle of the Tow Bar Locking Pin and rotate it (**Figure 15a**) to align the Spring Pins with the slot in the Tow Bar. Continue lifting until both Spring Pins are above the Tow Bar.
2. Rotate the Handle again until the Bottom Spring Pin is 90° to the Slots in the Tow Bar and lower the Handle until the Bottom Spring Pin (**Figure 15b**) rests on the Tow Bar. This is the unlocked position.
3. Move the Mower, using the Push Bar, until you have approximately aligned the Tow Bar with the desired Offset angle (**Figure 15**).
4. Lift the Handle and twist it until the Spring Pins align with the Slots in the Tow Bar. Press down to be sure to seat the Pin in the Mounting Plate hole (**Figure 15a**) at the desired location.

**NOTE:** If the Tow Bar alignment is correct and the Locking Pin is properly positioned, the Upper Spring Pin will not be showing. If the Upper Pin is still visible, adjust the Tow Bar angle by moving the Mower until the Locking Pin can be pushed down into place and the Upper Pin is no longer visible (**Figure 15b**).

5. Rotate the Handle to position the Upper Spring Pin out of alignment with the Slot in the Tow Bar (**Figure 15a**).

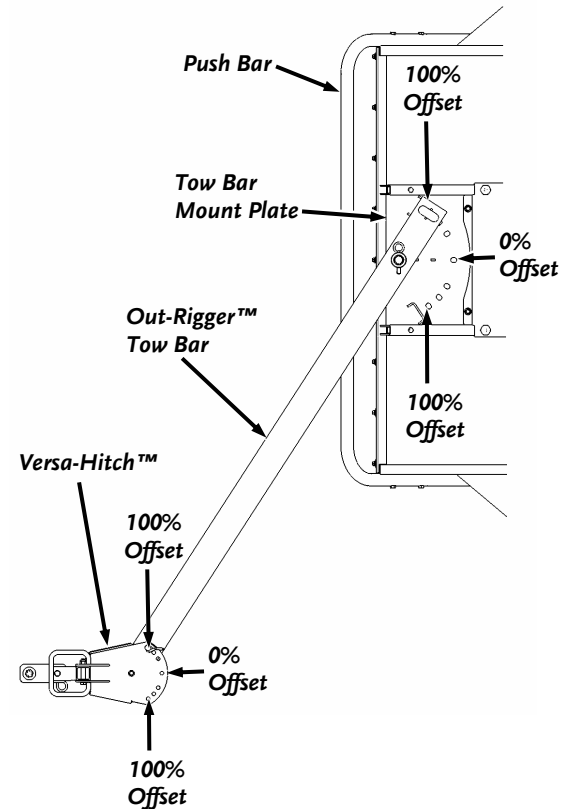

Figure 15

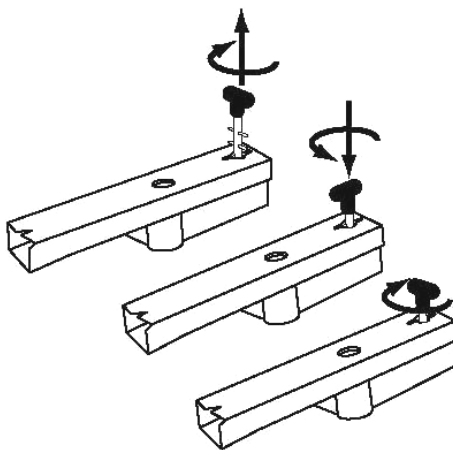

Figure 15a

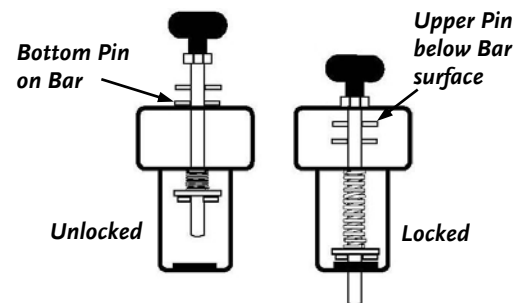

Figure 15b

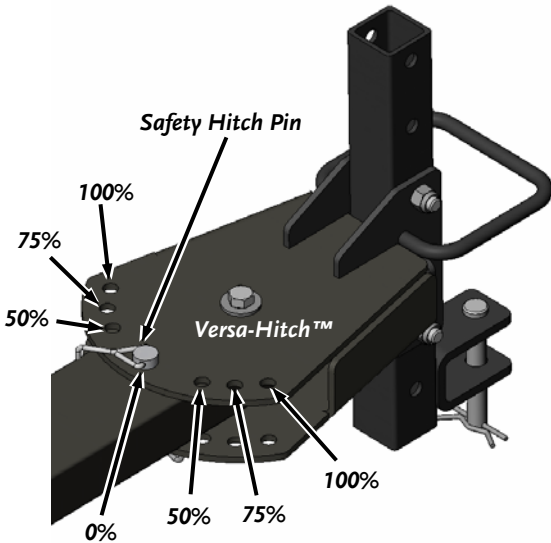

Figure 16

### **Offset at the Versa-Hitch™:**

1. Remove the Safety Hitch Pin (**Figure 16**) from the Versa-Hitch™ and pull the Out-Rigger™ Tow Bar to the position that matches the Tow Bar position on the Deck. Re-attach the Safety Hitch Pin.

**NOTE:** The Versa-Hitch™ is parallel to the machine when the Offset at the Deck and the Offset at the Hitch are matched correctly.

### **Slopes and Uneven Terrain**

#### **! WARNING!**

- Check the owner's manual for your tow vehicle to determine its recommended towing capabilities on slopes.
- When operating the TOW-BEHIND DR FIELD and BRUSH MOWER over uneven terrain or slopes, use extreme caution not to tip over the machine.
- Never use the TOW-BEHIND DR FIELD and BRUSH MOWER on slopes greater than 20 degrees. Doing so could result in serious injury or damage to your machine.
- If you have to mow on sloping terrain, mow up and down, never across the slope, for better control.

### **If the machine gets hung up**

1. Disengage the Blades and STOP the Engine. NEVER try to free the machine from stumps or debris with the Blades engaged.
2. Try driving over or backing away from the obstacle.

#### **! WARNING!**

- If you need to leave the tow vehicle to clear debris from the mower deck, set the parking brake and shut off the tow vehicle engine, disengage the mower blades, shut off the TOW-BEHIND DR FIELD and BRUSH MOWER engine and disconnect the spark plug wire(s).
- Never touch the exhaust areas when reaching for the spark plugs; they may be very hot.

### **Cutting Brush and Saplings**

1. The cutting capacity is 1-1/2" saplings.
2. When cutting woody material, small saplings, etc., allow the machine to ride up and over material slowly. Adjust your forward speed to varying conditions.
3. After cutting brush, etc., you may want to mow over it again to remove any remaining branches. It works best to mow from the trunk end toward the top as brush lies on the ground.
4. If you are using Offset Mowing, keep the Offset at 75% when cutting heavy brush.

### **Cutting Wet and Heavy Growth**

1. Avoid steep slopes and other slippery areas.
2. Use a lower, slower speed when mowing in wet conditions.

## Chapter 4: Maintaining The TOW-BEHIND DR FIELD and BRUSH MOWER

This chapter covers regular maintenance procedures that will ensure the best performance and long life of your TOW-BEHIND DR FIELD and BRUSH MOWER. For Engine maintenance, please refer to the Engine Owner's Manual that came with your machine. Service intervals listed in the checklist below supersede those listed in the Engine Owner's Manual.

### **WARNING!**

- When performing any adjustment or maintenance, you must first shut off the engine, wait five (5) minutes to allow parts to cool and disconnect the spark plug wire(s), keeping it away from the spark plug(s).
- Some of the following procedures require access to the underside of the machine. If you need to tip the machine back or on its side, you must first disconnect the spark plug wire(s), and drain the oil and gas.

### **Regular Maintenance Checklist**

**NOTE:** Consider the service intervals shown as maximum under normal operating conditions. Increase frequencies under extremely dirty or dusty conditions.

PROCEDURE	BEFORE EACH USE	EVERY 20 HOURS	EVERY 100 HOURS
Check Engine Oil Level	▲		
Check General Condition, e.g. nuts, bolts, welds, etc.	▲		
Check the Blades Sharpness	▲		
Inspect the Debris Guard	▲		
Clean Engine Exterior & Cooling Fins	▲		
Check Cable connections		▲	
Check Tire Pressure (psi on side of tire)		▲	
Change Engine Oil and Filter NOTE: 1 <sup>st</sup> time after 5		▲	
Replace Air Filter			▲
Replace Spark Plug(s)			▲
Replace In-line Gas Filter			▲

### **Removing and Replacing the Engine Oil and Filter**

### **WARNING!**

When performing any adjustment or maintenance, you must first shut off the engine, wait five (5) minutes to allow parts to cool and disconnect the spark plug wire(s), keeping it away from the spark plug(s).

**NOTE:** Drain the oil when the Engine is warm. Warm oil drains quickly and completely.

#### **Tools and Supplies Needed:**

- Oil Filter Wrench (obtainable from a local auto parts or hardware store)
- Rags and a suitable container for used oil
- SAE 30 High Detergent Oil

1. Attach the Plastic Hose provided to the Quick Release Oil Drain Valve located on the side of the Engines (**Figure 17**). Turn the Valve counterclockwise and pull out to drain the oil into a suitable oil receptacle.

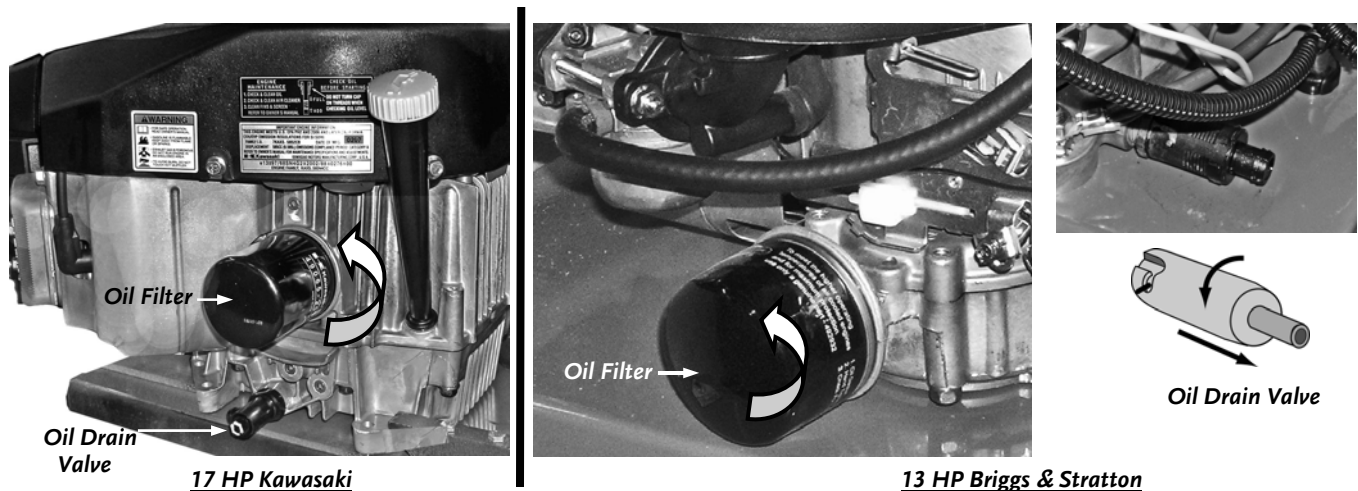

Figure 17

2. The Engine Oil Filter is located on the side of the Engine. Using an Oil Filter Wrench, or grasping the Oil Filter firmly with your hand, unscrew the Oil Filter counterclockwise from the Engine. **BE SURE THAT THE OLD FILTER GASKET COMES OFF WITH THE FILTER.**
3. Wipe the mounting base for the Oil Filter with a clean cloth.
4. Apply a thin coat of clean motor oil to the new Oil Filter Gasket. **DO NOT USE GREASE.**
5. Line up the threads carefully to avoid cross threading and screw the new Oil Filter on until the Filter Gasket contacts the base, and then tighten the Oil Filter 3/4 to 1 turn. **DO NOT OVER TIGHTEN.**
6. Replace the oil by following the instructions on page 10.
7. Reattach the Spark Plug wire(s).

**NOTE:** Be sure to use environmentally safe disposal procedures in the disposing of the used oil.

### Removing and Replacing the Blades' Drive Belt

#### **! WARNING!**

When performing any adjustment or maintenance, you must first shut off the engine, wait five (5) minutes to allow parts to cool and disconnect the spark plug wire(s), keeping it away from the spark plug(s).

#### **! NOTICE!**

Use only DR belts on your machine. They have been thoroughly tested and proven for many hours of use.

#### Tools and Supplies Needed:

- 7/16" and 1/2" Wrench or Socket
- Flat Screwdriver
- 9/16" Wrench
- Side Cutters or Scissors
- Hooked End Pulling Tool - Optional (we suggest a Tent Peg Puller)
- New Belt – Part Number 221331

1. Turn the Fuel Shut-Off Valve to the OFF position (**Figure 18**).
2. Using a 7/16" Wrench or Socket, remove the three Bolts, Lock Washers, and Flat Washers that retain the Pulley Cover and remove the Cover (**Figure 4 on page 11**).
3. Remove the Strain Relief (with Wire Harness) from the Fuel Tank Mount by pushing the tabs in with a screwdriver and pushing it out of the cutout.
4. Disconnect the Throttle Cable from the Engine and then slide it from behind the Fuel Tank Straps. See page 12 and follow the steps in the reverse order for your Engine.
5. Using a 1/2" Wrench or Socket, remove the four Bolts and Lock Washers that retain the Fuel Tank Mount (**Figure 18**).
6. Carefully lift and set the Fuel Tank Mount (**Figure 19**) to the Fuel Line side of the Engine.
7. Using a 9/16" Wrench, remove the top Nut from the Belt Tension Spring Mounting Stud (**Figure 20**).
8. Using a Hooked End Pulling Tool, remove the Belt Tension Spring from the Mounting Stud by hooking the Tool in the Spring End and pulling the Spring up and over the Stud
9. Using a 7/16" Wrench or Socket, remove the two Bolts and Lock Washers that retain the Rear Access Panel on the Mower (**Figure 21**) and remove the Panel.
10. Slip the old Drive Belt from the Drive Pulley (**Figure 22**) and from the Pulley beneath the Engine at the Rear of the Mower.
11. To install the new Belt, follow the above procedure in the reverse order making sure that the Belt is on the inside of the Tension Pulley (**Figure 20**).

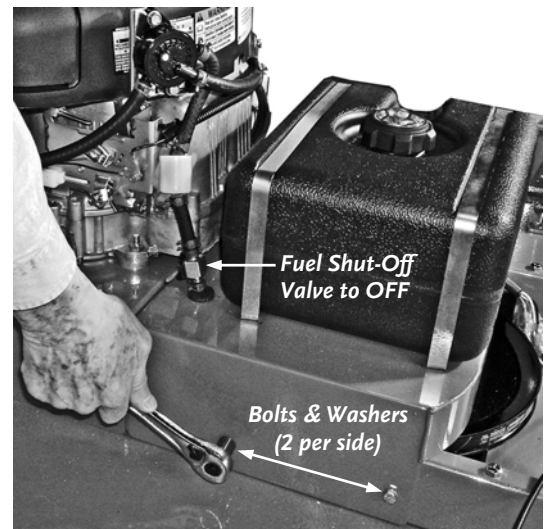

Figure 18

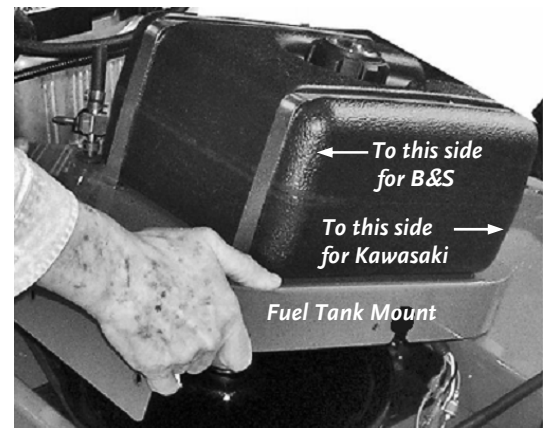

Figure 19

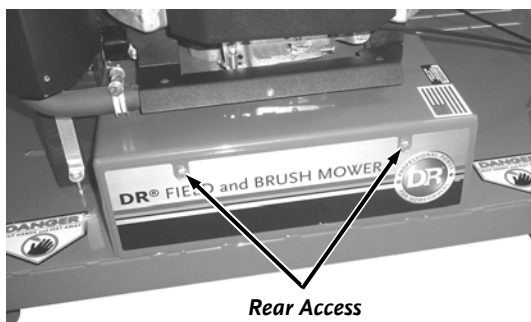

Figure 21

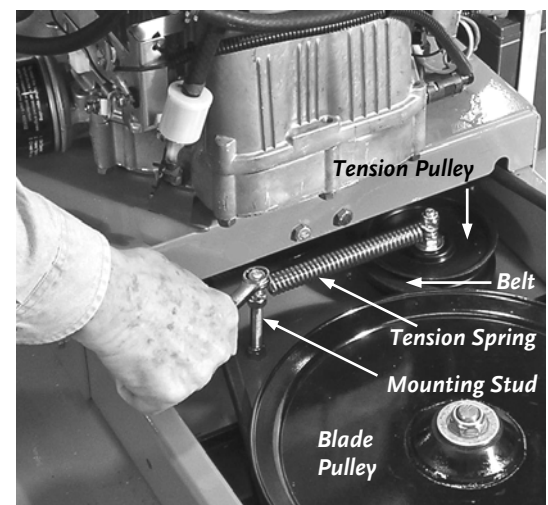

Figure 20

## Removing and Replacing the Swinging Blades

**NOTE:** Replace the Blade(s) when worn or damaged.

### **! WARNING!**

When performing any adjustment or maintenance, you must first shut off the engine, wait five (5) minutes to allow parts to cool and disconnect the spark plug wire(s), keeping it away from the spark plug(s).

#### Tools and Supplies needed:

- Two 15/16" Wrench
- Gloves

1. Using two 15/16" Wrenches, remove the Top Lock Nut (right-hand, regular thread), the Backing Nut, and then the Blade Bolt followed by the Pro-Tek™ Swinging Blade (**Figure 23**).

### **! WARNING!**

Use caution when pushing or pulling the wrench next to the blade. Wear gloves; if the wrench slips off the bolt, you may be seriously injured.

2. Reinstall the sharpened or a new Pro-Tek™ Swinging Blade in the orientation shown (**Figure 24**).
3. Install the Backing Nut until it seats finger tight against the Blade Carrier to allow for the Blade Swinging action (**Figure 23**).
4. Using two 15/16" Wrenches, install and tighten the Lock Nut against the Backing Nut while holding the Backing Nut with one Wrench and tightening the Lock Nut with the other Wrench.
5. Repeat steps 1 through 3 for the other Pro-Tek™ Swinging Blade.

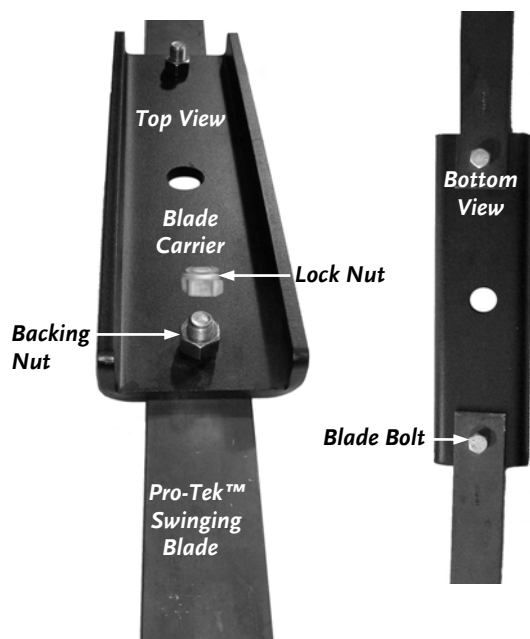

Figure 23

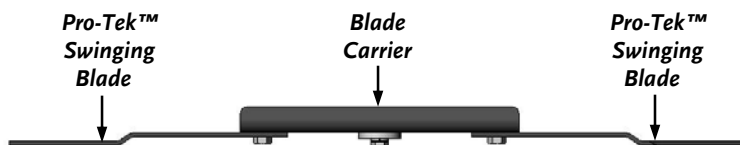

Figure 24

## Replacing the Wheels

### **! WARNING!**

When performing any adjustment or maintenance, you must first shut off the engine, wait five (5) minutes to allow parts to cool and disconnect the spark plug wire(s), keeping it away from the spark plug(s).

#### Tools needed:

- 9/16" Wrench or Socket
- Wheel – Part Number 222321

1. With the weight of the machine on the wheel, loosen (counterclockwise) the Axle Bolt (**Figure 25**) with a 9/16" Wrench or Socket.
2. Block the machine up off the ground so that the Wheel you are removing spins freely, remove the Axle Bolt, Lock Washer, Flat Washer, and Outer Bushing.
3. Slide the Wheel from the Axle.

**NOTE:** If the Inner Bushing should slip out when removing the Wheel, simply re-insert it on the Step & Mow™ Axle Shaft.

4. Replace the Wheel and hardware in the reverse order.

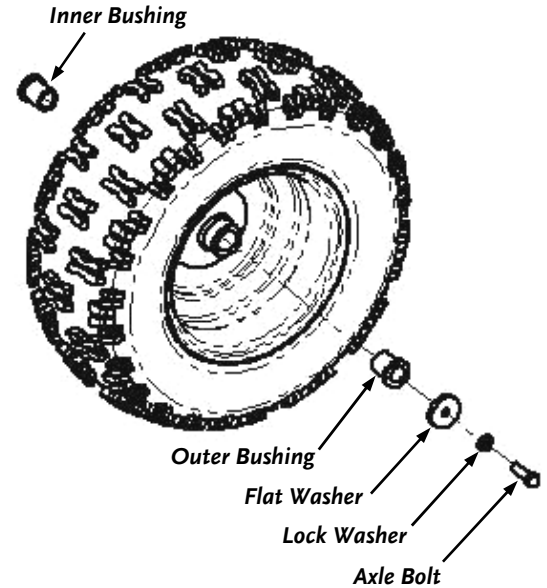

Figure 25

## Debris Guard Replacement

The purpose for this section is to be sure the operator of the TOW-BEHIND DR FIELD and BRUSH MOWER is aware of the potential unsafe condition of operating the machine with a damaged Debris Guard.

### **! WARNING!**

- When performing any adjustment or maintenance, you must first shut off the engine, wait five (5) minutes to allow parts to cool and disconnect the spark plug wire(s), keeping it away from the spark plug(s).
- Do not operate your TOW-BEHIND DR FIELD and BRUSH MOWER with a damaged debris guard. Failure to replace the damaged debris guard can result in thrown objects hitting the operator, which can cause severe injury.

- Inspect the Debris Guard before each use and often during use. If you notice damage to the Debris Guard, DO NOT continue to use your machine.
- Consider a Debris Guard (**Figure 26**) damaged when a flap is missing or torn.
- If your Debris Guard is damaged call us Toll-Free at 1-800-DR-OWNER (376-9637) and we will ship a replacement at no cost to you.
- If you have any questions, please call Toll-Free at 1-800-DR-OWNER (376-9637). Our Technical Service Support Staff is available between 8:30 am and 5:00 pm Eastern Time, Monday through Saturday.

## Battery Care

Proper care can extend the life of a Battery. Follow these recommendations to ensure your Battery's best performance and long life:

- Do not allow the Battery charge to get too low. If the machine is not used, charge the Battery every 4 – 6 weeks. Operate the Engine for at least 45 minutes to maintain proper Battery charge.
- Store an unused Battery in a dry area that does not freeze.

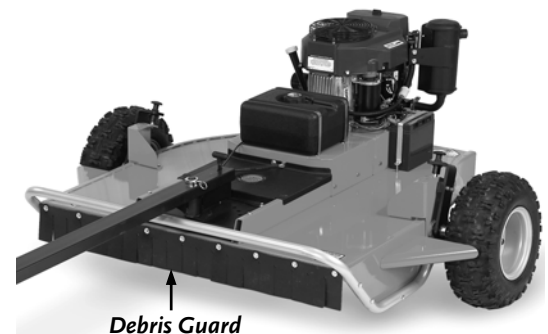

Figure 26

- Do not charge an already charged Battery. In theory, you cannot overcharge our Battery with a trickle charger; however, when a Battery is fully charged and the charger is still on, it generates heat that could be harmful to the Battery. A fully charged Battery will read 12V-13.2V with a voltmeter.
- Do not continue to crank the Engine when the Battery charge is low.



## Chapter 5: Troubleshooting

Most problems are easy to fix. Consult the Troubleshooting Table below for common problems and their solutions. If you continue to experience problems, contact us at [www.DRpower.com](http://www.DRpower.com) or call toll-free 1-800-DR-OWNER (376-9637) for support.



When performing any adjustment or maintenance, you must first shut off the engine, wait five (5) minutes to allow parts to cool and disconnect the spark plug wire(s), keeping it away from the spark plug(s).

### Troubleshooting Table

SYMPTOM	POSSIBLE CAUSE
<p><i>The Engine will not start.</i></p> <p><i>(Please refer to the Engine Owner's Manual for Engine-specific procedures.)</i></p>	<ul style="list-style-type: none"> <li>⇒ Check all the items under the section called “Starting” on page 15.</li> <li>⇒ Check that the Blade Control Knob is DOWN in the Disengaged position.</li> <li>⇒ Make sure the Spark Plug wire(s) is attached.</li> <li>⇒ If the Engine is cold, make sure the Throttle is in the CHOKE position. See “Starting” on page 15.</li> <li>⇒ The gas must be fresh and clean. If the gas is old, change it. Use a fuel stabilizer if you keep gas longer than one month.</li> <li>⇒ Check the Throttle adjustment and travel. See page 12.</li> <li>⇒ The Spark Plug(s) may be dirty or cracked, change it.</li> <li>⇒ If the Spark Plug(s) is oily, leave it out, hold a rag over the Plug hole(s) and crank the Engine over a couple of times using the Electric Starter to blow out any oil in the Cylinder(s), then wipe off the Plug(s) and reinsert it.</li> <li>⇒ The Air Filter may be dirty, change it following the procedure in the Engine Owner’s Manual.</li> <li>⇒ There are two Fuses in the Wiring Harness. Check the Fuses and replace if needed.</li> <li>⇒ Check the wire connections—especially the ground connection, the large green wire coming from the Battery, where it connects to the Engine.</li> <li>⇒ The Battery may not be charged. Check the voltage yourself or at a service station. If it is low, charge it with a 12-volt, 1 to 2-amp trickle charger. If you do not use your machine for at least 45 minutes at a time, the Battery may need to be periodically charged. See the “Battery Care” section on page 23.</li> <li>⇒ If the Battery is charged and your DR TOW-BEHIND FIELD &amp; BRUSH MOWER still will not start, visit our website at <a href="http://www.DRpower.com">www.DRpower.com</a> or call 1-800-DR-OWNER (376-9637) for assistance.</li> </ul>
<p><i>The Engine lacks power or is not running smoothly.</i></p> <p><i>(Please refer to the Engine Owner's Manual for Engine-specific procedures.)</i></p>	<ul style="list-style-type: none"> <li>⇒ Check the Throttle Lever travel and adjustment. Make sure the Throttle Lever is in the Run position.</li> <li>⇒ The Air Filter may be dirty, change it following the procedure in the Engine Owner’s Manual.</li> <li>⇒ The Spark Plug(s) may be dirty or cracked, change it.</li> <li>⇒ If the Spark Plug(s) is oily, leave it out, hold a rag over the Plug hole(s) and crank the Engine over a couple of times using the Electric Starter to blow out any oil in the Cylinder(s), then wipe off the Plug(s) and reinsert it.</li> <li>⇒ The gas must be fresh and clean. If the gas is old, change it. Use a fuel stabilizer if you keep gas longer than one month.</li> <li>⇒ The Engine may not have the right amount of clean oil. If it is dirty, change it following the procedure on page 19.</li> <li>⇒ If the Engine still lacks power, visit our website at <a href="http://www.DRpower.com">www.DRpower.com</a> or call 1-800-DR-OWNER (376-9637) for assistance.</li> </ul>

**! WARNING!**

When performing any adjustment or maintenance, you must first shut off the engine, wait five (5) minutes to allow parts to cool and disconnect the spark plug wire(s), keeping it away from the spark plug(s).

**Troubleshooting Table (Continued)**

SYMPTOM	POSSIBLE CAUSE
<i>Engine smokes.</i>	<ul style="list-style-type: none"> <li>⇒ Check the oil level and adjust as needed.</li> <li>⇒ You may be operating the machine on too great an incline. See “Slopes and Uneven Terrain” on page 18.</li> <li>⇒ Check the Air Filter(s) and clean or replace if needed.</li> <li>⇒ You may be using the wrong oil—too light for the temperature. Refer to your Engine Owner’s Manual for detailed information.</li> <li>⇒ Clean the Cooling Fins and the Carburetor housing if they are dirty.</li> <li>⇒ If the Engine still smokes, visit our website at <a href="http://www.DRPower.com">www.DRPower.com</a> for assistance</li> </ul>
<i>The Belt frays or rolls over the Pulley.</i>	<ul style="list-style-type: none"> <li>⇒ There may be a nick in a Pulley groove. Check the Belt for wear and hard spots. File off any nicks on the Pulley.</li> <li>⇒ The Belt may be stretched; replace it. See page 20.</li> </ul>
<i>Blades vibrate when engaged.</i>	<ul style="list-style-type: none"> <li>⇒ The Blade Carrier Mounting Bolt may not be tight enough. Tighten the Bolt as tight as possible by hand with at least a 1ft long 13/16" Wrench.</li> <li>⇒ A Swinging Blade may be too loose on the Blade Carrier. Re-tighten the Swinging Blade mounting hardware. See page 22. Be sure to turn OFF the Engine and remove the Spark Plug wire(s) before performing this operation.</li> <li>⇒ Replace a Swinging Blade if it is chipped, bent, or broken.</li> <li>⇒ The Spindle Bearings may be damaged or the Spindle Shaft is bent.</li> <li>⇒ Call 1-800-DR-OWNER (376-9637) for assistance.</li> </ul>
<i>The Blades are not cutting or are loose.</i>	<ul style="list-style-type: none"> <li>⇒ The Blade Carrier Mounting Bolt may not be tight enough. Tighten the Bolt as tight as possible by hand with at least a 1ft long 13/16" Wrench.</li> <li>⇒ A Swinging Blade may be too loose on the Blade Carrier. Re-tighten the Swinging Blade mounting hardware. See page 22. Be sure to turn OFF the Engine and remove the Spark Plug wire(s) before performing this operation.</li> <li>⇒ Sharpen the Swinging Blades; they may be dull or nicked.</li> </ul>
<i>The Blades will not Engage and/or Disengage.</i>	<ul style="list-style-type: none"> <li>⇒ Faulty Blade Control Switch. Remove and replace the Switch on the Remote Control Panel.</li> <li>⇒ Faulty Electric Clutch. Call 1-800-DR-OWNER (376-9637) for assistance.</li> </ul>
<i>Uneven cut.</i>	<ul style="list-style-type: none"> <li>⇒ The Step &amp; Mow™ Height Adjuster and Versa-Hitch™ position are out of sync. Adjust the cutting height or Versa-Hitch™ position so that the Out-Rigger™ Tow Bar is level with the ground.</li> <li>⇒ Left and Right Step &amp; Mow™ Height Adjusters are not at the same setting.</li> </ul>
<i>Clogging at discharge.</i>	<ul style="list-style-type: none"> <li>⇒ The Step &amp; Mow™ Height Adjuster and Versa-Hitch™ position are out of sync. Adjust the cutting height or Versa-Hitch™ position so that the Out-Rigger™ Tow Bar is level with the ground.</li> </ul>
<i>Excessive Engine stalling.</i>	<ul style="list-style-type: none"> <li>⇒ The brush or grass is too heavy at the current cutting height or at the current Tow Vehicle speed. Raise the cutting height and drive slower when cutting.</li> </ul>

## Chapter 6: Parts Lists, Schematic Diagrams And Warranty

### Parts List - Deck and Drive Assembly

**NOTE:** Part numbers listed are available through DR Power Equipment.

Ref#	Part#	Description	Ref#	Part#	Description
01	229501	Deck w/Labels	38	221411	Anti-Rotation Bracket
02	221361	Support, Deck	39	123211	Bolt, 5/16"-18 x .75", HCS, GR5, ZP
03	222131	Bolt, 5/16"-18 x 3.62", HCS, GR5, ZP	40	221331	Belt, BP51, 5/8" x 53.8"
04	112411	Washer, Flat, 5/16", USS, ZP	41	222201	Idler Arm
05	110761	Nut, Nylon Lock, 5/16"-18, ZP	42	222211	Bushing, .390" ID x .625" OD x .78"
06	222451	Valve, 3/8" NPT, Oil Drain (B&S only)	43	119851	Bolt, 3/8"-16 x 1.5", HCS, GR5, ZP
07	221381	Mount, Tow Bar, Deck	44	112391	Washer, Flat, 3/8", USS, ZP
08	222461	Bolt, 3/8"-16 x .75", HCS, GR8, ZP, YZP	45	151271	Pulley, Flat Idler, 4", 3/8" Bore
09	222471	Bolt, 3/8"-16 x 2.25", HCS, GR8, ZP, YZP	46	150691	Bolt, 3/8"-16 x 2.5", HCS, GR5
10	222531	Washer, Lock, 3/8", Split, GR8, YZP	47	150941	Spring, Ext., .75" OD x 5.0" L
11	221291	Spindle, Housing	48	179261	Bolt, 3/8"-16 x 3.5", HCS, GR5, ZP, Full Thread
12	228881	Bolt, 3/8"-16 x 1", HCS, GR8, ZP, YZP	49	222251	Wire Harness, Solenoid, B&S
13	110751	Nut, Nylon Lock, 3/8"-16, ZP		222491	Wire Harness, Solenoid, Kawasaki
14	221301	Shaft, Spindle, w/Key & Bearing	50	152501	Bolt, 1/4"-20 x .75", HCS, w/Flange
15	221311	Bearing, Ball, 30mm Bore	51	101811	Washer, Lock, 1/4", Split, ZP
16	221321	Pulley, 12.00" EOD, 1.00" Bore	52	112381	Washer, Flat, 1/4", USS, ZP
17	157451	Washer, Flat, 5/8", USS, ZP	53	230811	Strain Relief, 1/2" Cord
18	221261	Nut, Nylon Lock, 5/8"-18, Low Profile, ZP	54	104831	Battery, 12V, 17Ah
19	212401	Spindle Hub, 30mm Bore	55	124511	Clamp, Battery, 7.12" X 5.5"
20	221221	Blade Carrier	56	111481	Bolt, 1/4"-20 x 1.75", HCS, GR5, ZP
21	101771	Washer, .64" ID x 2.25" OD x 3/8", ZP	57	110731	Nut, Nylon Lock, 1/4"-20, ZP
22	212581	Washer, Lock, 5/8", Split, Heavy Duty, YZP	58	150141	Wire, Ground, 16"
23	212411	Bolt, 5/8"-18 x 1.75", HCS, GR8, ZP, YZP	59	235301	Mount, Fuel Tank, 2.5 Gal.
24	221211	Blade, Swinging, 16.5" x 2.5"	60	222381	Fuel Tank Assy, 2.5 Gal., w/Elbow
25	221251	Nut, Hex, 5/8"-18, GR8, ZP, YZP	61	222371	Strap, 2.5 Gal. Fuel Tank
26	221371	Mount, Engine	62	110701	Nut, Hex, 1/4"-20, ZP
27	222181	Engine, 13HP, B&S, E/S, w/Fuel Pump	63	222441	Grommet, 1/2" ID x .12" Mount, Rubber
	235421	Engine, 17HP, Kawasaki, E/S	64	112431	Washer, Lock, 5/16", Split, ZP
28	228851	Bolt, 5/16"-18 x 1.5", HCS, GR8, ZP	65	247261	Cover, Belt w/Label
29	229271	Bolt, 5/16"-18 x 1.75", HCS	66	229521	Cover, Clutch Access w/Label
30	110691	Nut, Hex, 5/16"-18, ZP	67	100661	Clamp, Fuel Line
36	222521	Washer, Lock, 7/16", Heavy Duty	68	222391	Valve, Fuel Shutoff
37	222141	Bolt, 7/16"-20 x 2.25", Locking, HCS, GR8, YZP	69	112481	Washer, Lock, 1/4"

<b>Ref#</b>	<b>Part#</b>	<b>Description</b>
70	211661	Hose, Fuel, CA Certified
71	234021	Bolt, 5/8"-18 x 1.5", GR8, ZP
72	240541	Strain Relief, .5" Cord
73	230941	Spring, E, .31" OD x 1.25" (B&S only)
	153651	Spring, E, .31" OD x 2.00" (Kawasaki only)
74	164131	Nut, Nylon Lock, 3/8-16, Low Profile
75	222451	Valve, 3/8" NPT, Oil Drain (B&S only)

**Items Not Illustrated**

140021	Tubing, Oil Drain
235131	Guard, Engine Front (Kawasaki only)
230801	Screw, 6MM x 12 MM, SHCS, (Kawasaki Guard only)

142201	Fuse, 20 Amp, Type AGC
229001	Fuse, 7 Amp, Type AGC
112141	Cable Tie, 7.5" L
153531	Conduit, Split, 7/16" (Kawasaki Guard only)
222451	Muffler (Kawasaki only)

**Safety and Information Labels**

222671	Label, DR TOW-BEHIND FIELD & BRUSH MOWER
240531	Label, DR, 4" Round
124371	Label, American Flag
136491	Label, Danger
136831	Label, Caution Hot Surface
137581	Label, Check Oil
230901	Label, Serial Number

# Schematic – Deck and Drive Assembly

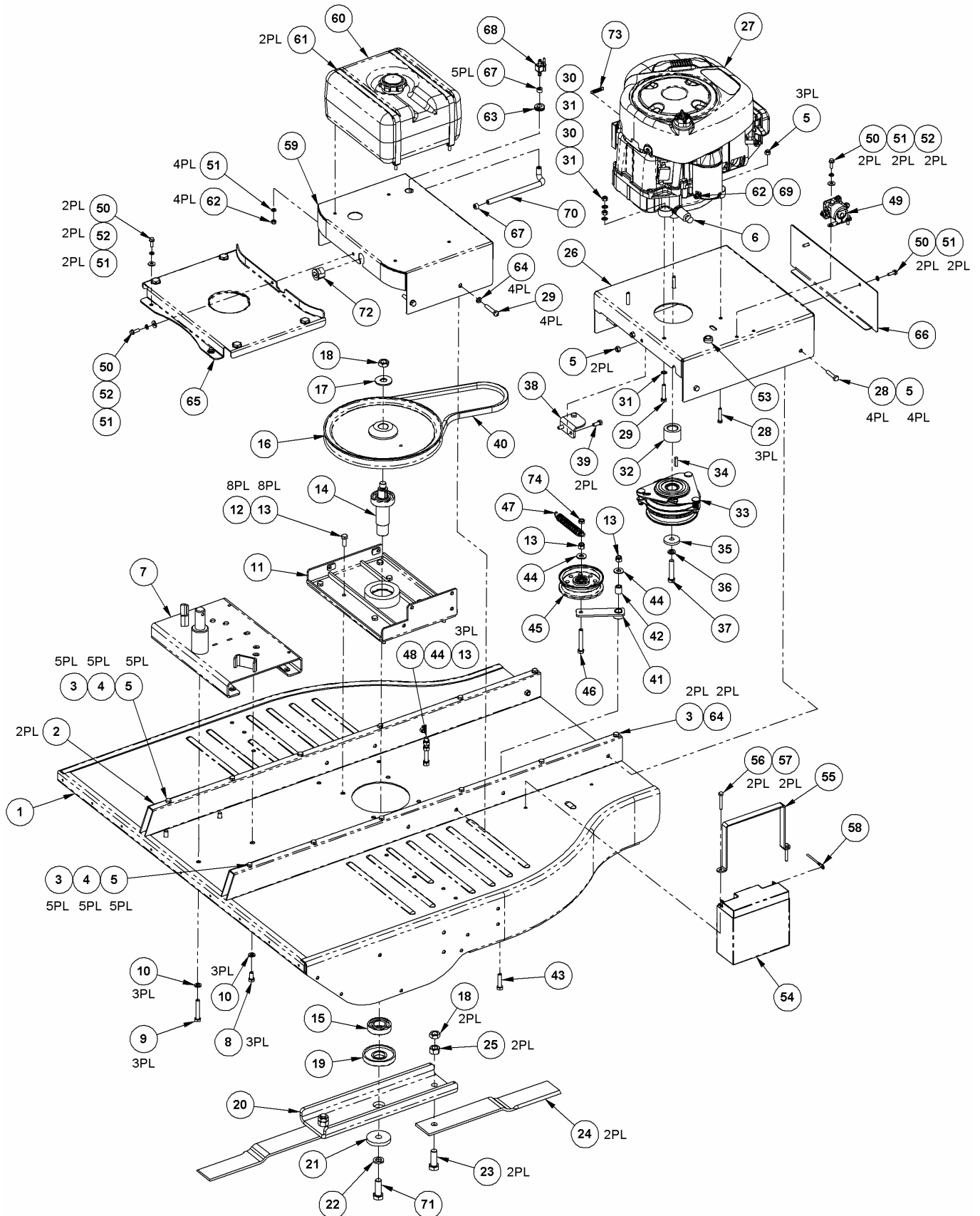

## Parts List – Wheels and Push Bar Assembly

**NOTE:** Part numbers listed are available through DR Power Equipment.

<u>Ref#</u>	<u>Part#</u>	<u>Description</u>	<u>Ref#</u>	<u>Part#</u>	<u>Description</u>
01	240251	Support, Axle Pivot, LH	15	222321	Wheel, 18" x 6.5-8, 1.0" Bore x 3.0" Long
02	240241	Support, Axle Pivot, RH	16	221511	Bushing, .75" ID x 1.00" OD x 1.25", Flange
03	123211	Bolt, 5/16"-18 x .75", HCS, GR5, ZP	17	240351	Deflector, Wheel, LH
04	110761	Nut, Nylon Lock, 5/16"-18, ZP	18	240341	Deflector, Wheel, RH
05	240231	Axle, Adjustable, LH	19	222461	Bolt, 3/8"-16 x .75", HCS, GR8, ZP
06	240221	Axle, Adjustable, RH	20	221341	Push Bar
07	221501	Bushing, 1.00" ID x 1.25" OD x 1.00"	21	229271	Bolt, 5/16"-18 x 1.75", HCS, ZP
08	228861	Bolt, 3/8"-16 x 1.25", HCS, GR8, ZP	22	222271	Guard, Deck Front
09	222531	Washer, Lock, 3/8", Split, GR8, ZP	23	152501	Bolt, 1/4"-20 x .75" w/Flange, HCS
10	228871	Washer, .385" ID x 1.50" OD x .25", ZP	24	112381	Washer, Flat, 1/4", USS, ZP
11	221591	Pin Assy, 1/2", w/Spring	25	101811	Washer, Lock, 1/4", Split, ZP
12	230821	Spacer, 2.5" x 1.25" x .75", Nylon	26	111581	Bolt, 5/16"-18 x 1", HCS, GR5, ZP
13	160861	Bolt, 1/4"-20 x 1.25", HCS, ZP	27	151401	Screw, Tri-Lobe, 1/4"-20 x .75", Flanged, GR2
14	110731	Nut, Nylon Lock, 1/4"-20, ZP			

# Schematic – Wheels and Push Bar Assembly

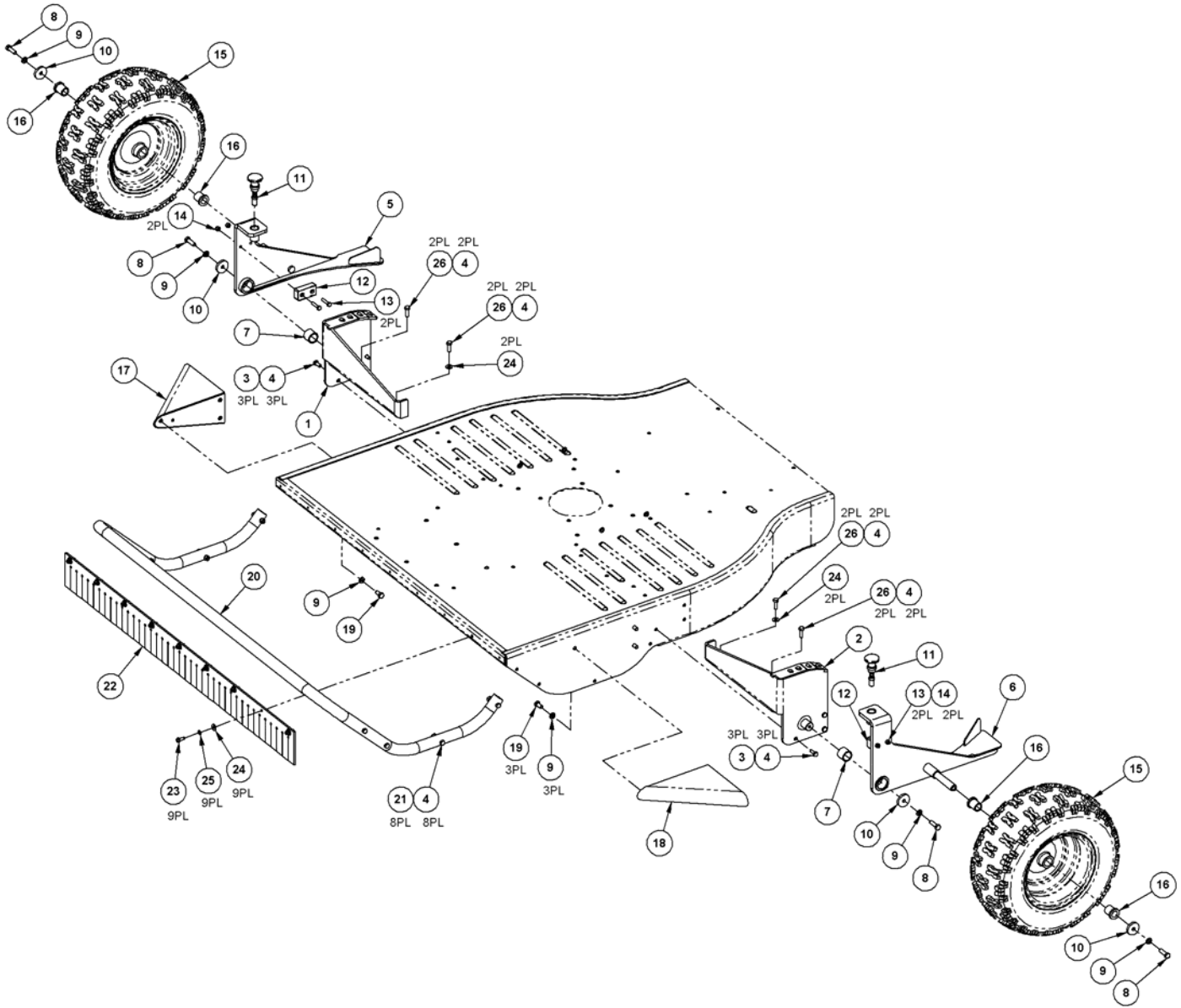

## Parts List – Tow Bar and Remote Control Panel Assembly

**NOTE:** Part numbers listed are available through DR Power Equipment.

<u>Ref#</u>	<u>Part#</u>	<u>Description</u>	<u>Ref#</u>	<u>Part#</u>	<u>Description</u>
01	221471	Tow Bar	21	157201	Key, Ignition Switch
02	221561	Bushing, 1.75" ID x 2.00" OD x 2.75", Teflon	22	191231	Switch, Push/Pull, TPDT
03	221491	Washer, 1.00" ID x 1.62" OD, w/Pin Hole	23	222241	Cable & Lever, Throttle, 154" (B&S)
04	150461	Pin, Detent, 1/4" x 2", ZP		222481	Cable & Lever, Throttle, 170" (Kawasaki)
05	234981	Pin, Pivot, Tow Bar	24	230911	Knob, 3/8"-24, Mount, 1.12" OD
06	221541	Pin, Spring, 1/8" x 1", ZP	25	114781	Screw, 10-24 x 5/8", Phil Pan, ZP
07	221551	Knob, 3/8"-16, 2.5" Long x 7/8" Wide T	26	118731	Nut, Nylon Lock, 10-24, ZP
08	126831	Nut, Hex, 3/8"-16, ZP	27	222261	Wire Harness, Control
09	213481	Spring, C, .660" OD x .067" Wire x 2.0"	28	230811	Strain Relief, 1/2" Cord
10	234991	Washer, .53" ID x 1.06" OD x .095", ZP	29	235001	Pin, Cotter, 7/16" x 1", ZP
11	221461	Pivot, Tow Bar	30	164841	Bolt, 3/8"-16 x 2-1/2", HCS, ZP
12	221571	Bushing, .386" ID x .623" OD x 1.915"	31	254761	Tongue, TB1 Hitch
13	123371	Bolt, 3/8"-16 x 2.75", HCS, GR5, ZP	<b><u>Items Not Illustrated</u></b>		
14	112391	Washer, Flat, 3/8", USS, ZP		191651	Strap, Hook and Loop
15	110751	Nut, Nylon Lock, 3/8"-16, ZP		111581	Bolt, 5/16"-18 x 1", HCS, GR5, ZP
16	211551	Pin, Quick Release, 3/8" x 2.5"	<b><u>Safety and Information Labels</u></b>		
17	211541	Pin, Clevis, 1/2" x 3.5" L, ZP		222221	Label, Control Panel
18	160031	Pin, Hitch Clip, 1/2" to 9/16"		127811	Label, Warning, Add Oil
19	213251	Control Panel			
20	222231	Switch, Snap-In, Electric Start			



# Tow Bar and Remote Control Panel Assembly

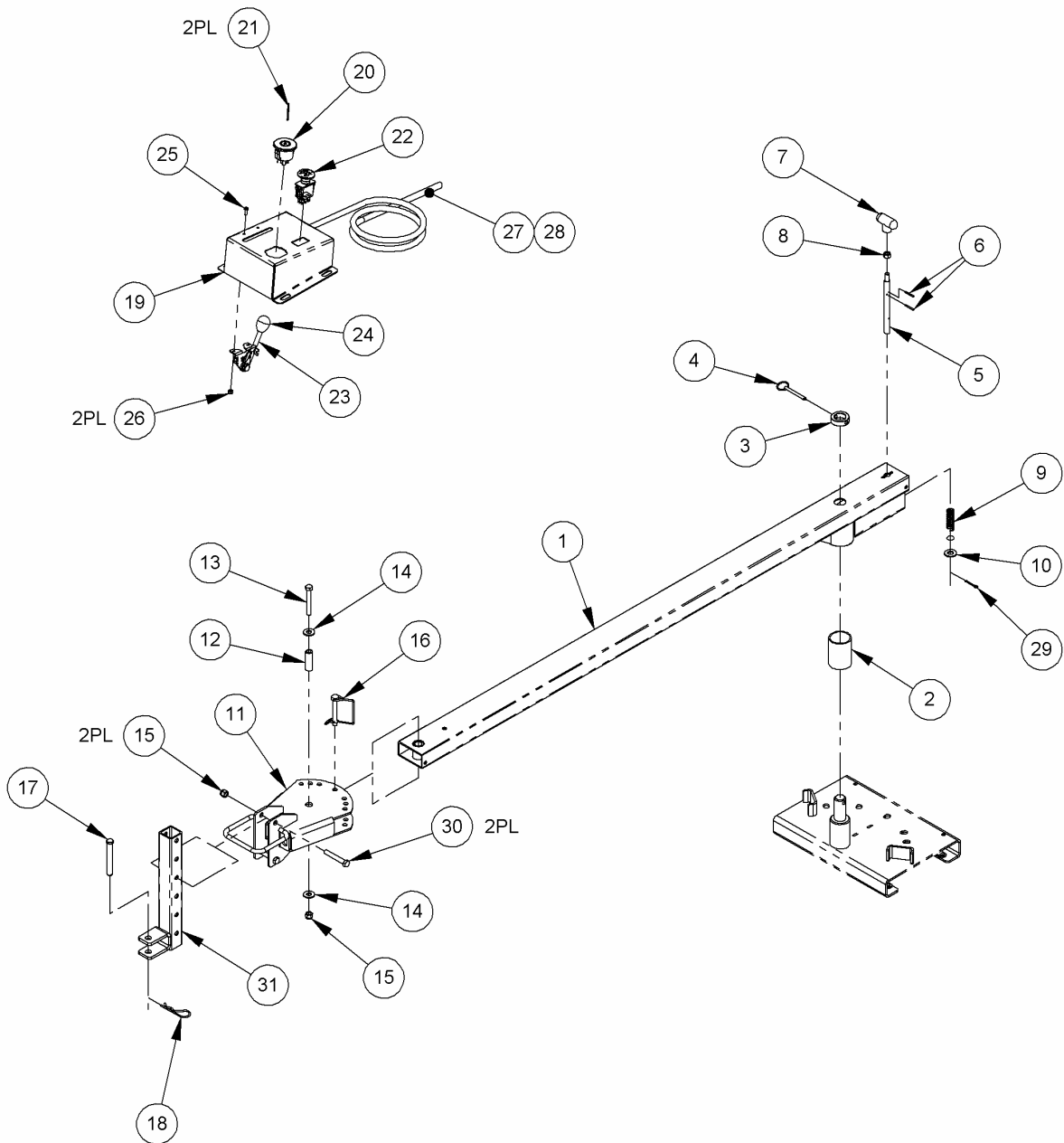

**Notes:**

# TOW-BEHIND DR<sup>®</sup> FIELD and BRUSH MOWER



## 2-Year Limited Warranty

### Terms and Conditions

The TOW-BEHIND DR<sup>®</sup> FIELD and BRUSH MOWER is warranted for two (2) years against defects in materials or workmanship when put to ordinary and normal consumer use; ninety (90) days for any other use. The Engine manufacturer warrants the Engine separately. The Battery is warranted for one (1) year.

For the purposes of all the above warranties, "ordinary and normal consumer use" refers to non-commercial residential use and does not include misuse, accidents, or damage due to inadequate maintenance.

DR<sup>®</sup> Power Equipment certifies that the TOW-BEHIND DR<sup>®</sup> FIELD and BRUSH MOWER is fit for ordinary purposes for which a product of this type is used. DR<sup>®</sup> Power Equipment however, limits the implied warranties of merchantability and fitness in duration to a period of two (2) years in consumer use, ninety (90) days for any other use.

The 2-Year Limited Warranty on the TOW-BEHIND DR<sup>®</sup> FIELD and BRUSH MOWER starts on the date the machine ships from our factory. The 2-Year Limited Warranty is applicable only to the original owner.

The warranty holder is responsible for the performance of the required maintenance as defined by the manufacturer's owner's manuals. The warranty holder is responsible for replacement of normally wearing parts such as the Debris Guard, Drive Belts, Blades, Tires, Filters, and Spark Plug(s). This warranty does not cover attachments and accessories to the machine.

During the warranty period, the warranty holder is responsible for the machine transportation charges, if required. During the warranty period, warranty parts will ship by standard method at no charge to the warranty holder. Expedited shipping of warranty parts is the responsibility of the warranty holder.

**SOME STATES DO NOT ALLOW LIMITATIONS ON THE LENGTH OF IMPLIED WARRANTIES, SO THE ABOVE LIMITATIONS MAY NOT APPLY TO YOU.**

DR<sup>®</sup> Power Equipment shall not be liable under any circumstances for any **incidental or consequential damages or expenses** of any kind, including, but not limited to, cost of equipment rentals, loss of profit, or cost of hiring services to perform tasks normally performed by the TOW-BEHIND DR<sup>®</sup> FIELD and BRUSH MOWER.

**SOME STATES DO NOT ALLOW THE EXCLUSION OR LIMITATION OF INCIDENTAL OR CONSEQUENTIAL DAMAGES, SO THE ABOVE LIMITATIONS MAY NOT APPLY TO YOU.**

**THIS WARRANTY GIVES YOU SPECIFIC LEGAL RIGHTS, AND YOU HAVE OTHER RIGHTS, WHICH VARY FROM STATE TO STATE.**

## Daily Checklist for the TOW-BEHIND DR FIELD and BRUSH MOWER

To help maintain your **TOW-BEHIND DR FIELD and BRUSH MOWER** for optimum performance, we recommend you follow this checklist each time you use your machine.

---

### **WARNING!**

When performing any adjustment or maintenance, you must first shut off the engine, wait five (5) minutes to allow parts to cool and disconnect the spark plug wire(s), keeping it away from the spark plug(s).

---

- Check the engine oil and Gas Tank level.
- Check that Engine is clean of debris.
- Check the general condition of the Mower, e.g.; nuts, bolts, welds, etc.
- Check Tire Pressure and wear.
- Check the Frame for wear and damage.
- Check the Blades and Spindle for tightness, nicks, cracks, wear or debris that has wrapped around.
- Check that the Remote Control Panel is secure.
- Check the Debris Guard for wear or damage.

### End of Season and Storage

---

### **WARNING!**

When performing any adjustment or maintenance, you must first shut off the engine, wait five (5) minutes to allow parts to cool and disconnect the spark plug wire(s), keeping it away from the spark plug(s).

---

**NOTE:** Please refer to the Engine Owner's Manual for Engine-specific procedures.

- Change the Engine oil and Oil Filter and replace the Fuel Filter.
- Remove the Spark Plug(s) and pour about 1 ounce of motor oil into the Cylinder hole. Replace the Plug(s) and crank the Engine over a couple of times using the Electric Starter. This will coat the pistons and seat the valves to prevent moisture buildup.
- Clean or replace the Air Filter(s).
- Clean dirt and debris from the Cylinder Head Cooling Fins, Blower Housing, Debris Screen, and Muffler area of the Engine.
- If your TOW-BEHIND DR FIELD and BRUSH MOWER will be idle for more than 30 days, we recommend using a gas stabilizer. This will prevent sediment from gumming up the Carburetor. If there is dirt or moisture in the gas or tank, remove it by draining the tank. Completely fill the tank with fresh, unleaded gas and add the appropriate amount of stabilizer or gasoline additive. Run the Engine for a short time to allow the additive to circulate.
- Remove any wrapped weeds from the Blades Carrier Housing. Clean grass and debris from the top and underneath the mower Deck with a stiff brush.
- Check the Blades for nicks and wear. Remove the Blades and sharpen them, or have them professionally sharpened if needed.
- Touch-up all rusted or chipped paint surfaces. Sand them lightly before painting.
- Be sure all nuts, bolts, and screws are securely fastened.
- Inspect moving parts and the Blades' Drive Belt for damage and wear; replace if necessary.
- Store the Battery in a dry area that will not freeze. If you will not use the machine over a long period, charge the Battery every four to six weeks.
- If possible, store your TOW-BEHIND DR FIELD and BRUSH MOWER inside, but not near an open flame or spark such as found in a water heater.
- After the TOW-BEHIND DR FIELD and BRUSH MOWER has cooled, cover the machine with a suitable protective cover that does not retain moisture. Do not use plastic as this material cannot breathe; it also allows condensation to form, which will cause your machine to rust.



---

75 MEIGS ROAD, P.O. BOX 25, VERGENNES, VERMONT 05491