

DR[®] 20-Ton WOOD SPLITTER

Safety & Operating Instructions

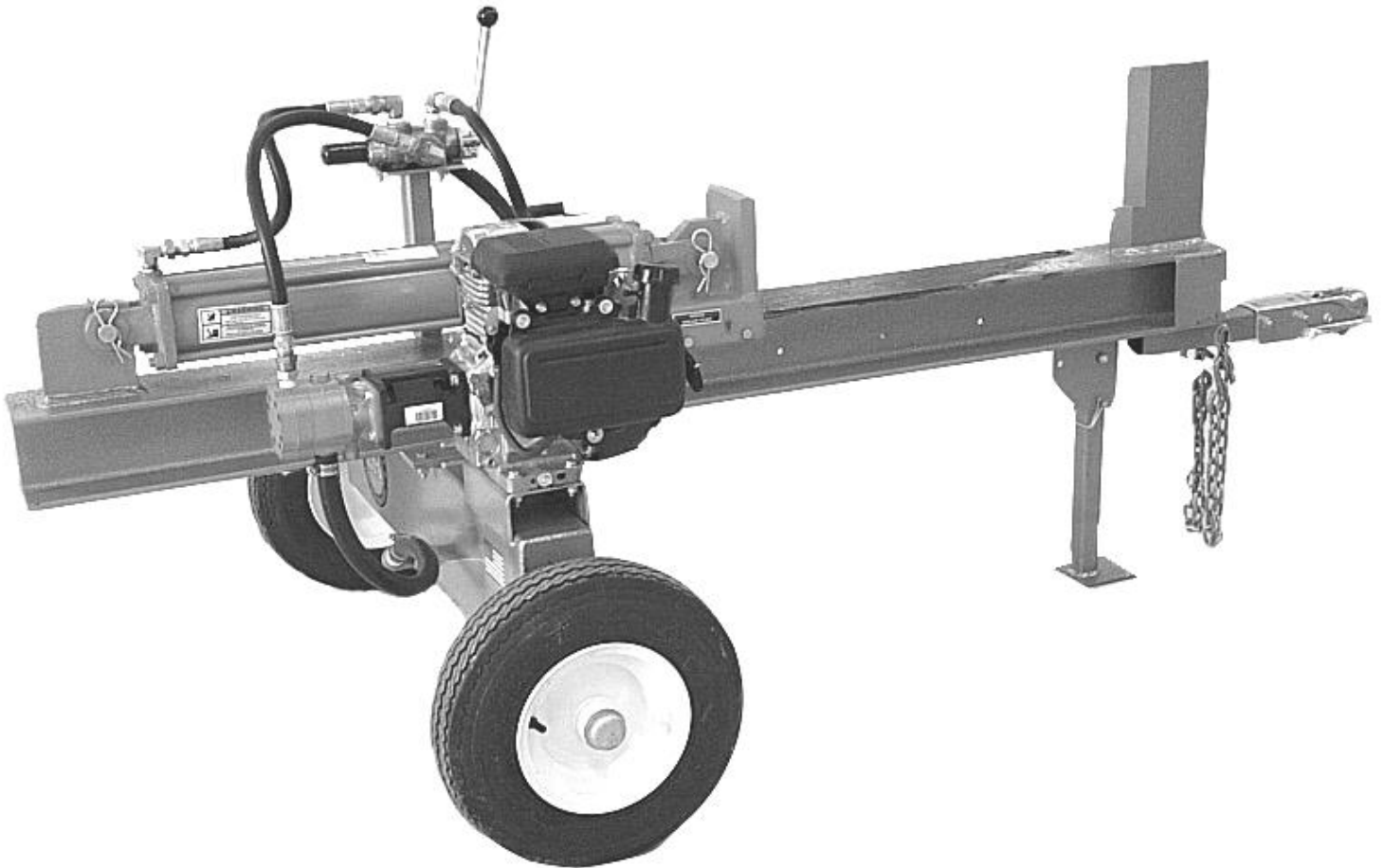

Please read instructions before operating machine

THANK YOU!

And congratulations on your purchase of a new DR 20-Ton WOOD SPLITTER!

We have done our utmost to ensure that your DR 20-Ton WOOD SPLITTER will be one of the most trouble-free and satisfying pieces of equipment you have ever owned. Please let us know of any questions or problems you may have. We want to answer or correct them as quickly as possible. (When you do call or write, please have your serial number and/or order number handy—it will speed things up!) We also hope to hear from you on how much you like your new helper.

And, please tell your friends about your new DR 20-Ton WOOD SPLITTER! Having DR Owners spread the word about our products and our way of doing business is the best advertising we can have, and the best way to help us provide even better service in the years to come.

Thanks once again!



for all of us at
Country Home Products, Inc.®

SALES MANAGER

COPYRIGHT

©2004 Country Home Products, Inc. All rights reserved.



Country Home Products, Inc.
Meigs Road
P.O. Box 25
Vergennes, VT 05491

Toll-free phone: 1-800-DR-OWNER (376-9637)

Fax: 1-802-877-1213

Web site: www.dr-owner.com

E-mail: info@chp.com

Table of Contents

Chapter 1: Introducing the DR 20-Ton WOOD SPLITTER.....	1
Conventions used in this manual.....	1
Chapter 2: Safety Considerations.....	3
Preparing to Use the DR 20-Ton WOOD SPLITTER	3
Safety Information Labels.....	3
Protecting Yourself	5
Operating the Machine Safely	5
Safety with Gasoline-Powered Machines	6
Hydraulic Safety	7
A Note to All Users	8
Additional Information and Potential Changes.....	8
Chapter 3: Setting Up Your DR 20-Ton WOOD SPLITTER.....	9
DR 20-Ton WOOD SPLITTER Controls and Features.....	9
Unpacking the Splitter and Installing the Wheels	10
Check the Tire Pressure.....	11
Log Cradle Installation (Optional).....	12
Manual Log Lift Installation (Optional).....	12
Table Grate Installation (Optional).....	14
Four-way, Reversible, Slip-on Wedge Installation (Optional)	15
Transporting the Splitter	16
Towing Safety.....	16
Checking the Engine Oil and Adding Gasoline.....	17
Chapter 4: Operating Your DR 20-Ton WOOD SPLITTER.....	19
Before Starting the Engine	19
Starting	19
Splitting Safety	20
Loading and Wedge Positioning.....	20
Operating the Wood Splitter	21
Chapter 5: Maintaining the DR 20-Ton WOOD SPLITTER	23
Regular Maintenance Checklist.....	23
Lubrication.....	24
Removing and Replacing the Engine Oil.....	25
Removing and Replacing the Hydraulic Fluid and Filter.....	26
Removing and Replacing the Hydraulic Hoses	28
Adjusting the Hydraulic Control Valve	29
End of Season & Storage.....	30
Chapter 6: Troubleshooting and Warranty	31
Troubleshooting Table.....	31

Chapter 1: Introducing the DR 20-Ton WOOD SPLITTER

This manual will help you set up and safely operate your new DR 20-Ton WOOD SPLITTER. Careful adherence to the safety and operating instructions in this manual will ensure many years of productive use.

Please let us know if you have any questions or problems by contacting Technical Support via our toll-free phone number. Our contact information is listed inside the front cover of this manual. When you call or write, please have your serial number or order number available so we can help you quickly.

Conventions used in this manual



WARNING! The exclamation point within a triangle alerts you to essential operating, safety, maintenance and servicing instructions.

Important! This information is important in the proper use of your machine. Failure to follow this instruction could result in injury to you and others or damage to your splitter.

Tip: This is a helpful hint to guide you in getting the most out of your splitter.

Tools Needed: This indicates you will need a special tool to perform a maintenance function on your machine.

Note: This information may be helpful to you.

If you are ever unsure about an action you are about to take, don't do it. Contact Country Home Products' toll-free support at 1-800-DR-OWNER (376-9637) for help or information.

Chapter 2: Safety Considerations

Taking the time to read and observe all safety instructions will ensure many years of productive use from your DR 20-Ton WOOD SPLITTER and help you avoid injury. Please take a few moments to read the following guidelines for safely operating your new machine.

Preparing to Use the DR 20-Ton WOOD SPLITTER

- Read these *Safety & Operating Instructions* and the engine owner manual before you use the DR 20-Ton WOOD SPLITTER. Become familiar with the controls, engine and service recommendations to ensure the best performance from your machine.
- Inspect the area in which you will be working. Locate the wood splitter only on firm, level ground. The site must be free of slippery surfaces and potentially hazardous obstacles.

Safety Information Labels

Take some time to become familiar with the following standard safety cautions applicable to your splitter. Replace damaged or missing safety labels immediately.



Keep combustible substances away from the engine when it is hot. (#136831)





Keep hands, feet, hair and clothing away from moving parts. (#199240)

⚠ DANGER

AVOID SERIOUS INJURY OR DEATH! - READ OWNER'S MANUAL!

ALWAYS place both handles in neutral position when starting engine!

- Do not use under the influence of drugs or alcohol.
- Keep bystanders, helpers, and children under 18 at least 10 feet away.
- Only one operator permitted. Adult who loads and holds log must be the one who operates control handle.
- NEVER handle firewood by the end.
- Stay clear of wedge area once the piece of firewood has entered splitting wedge.
- Keep hands away from splitter when push block is on the return stroke.

WHEN TRANSPORTING

- Make sure the front leg is retracted and pinned up before transporting.
- ALWAYS attach log splitter ball coupler to ball on tow vehicle.
- Make sure safety chains are securely attached.
- NEVER move log splitter with motor running.
- Make sure the fuel valve is in the "OFF" position.

This label reminds you about the importance of reading and understanding the Safety & Operating Instructions manual and of paying attention to the safety warnings. (#199250)

NOTICE

***HYDRAULIC OIL ONLY**

* REFER TO OWNER'S MANUAL FOR OIL SPECIFICATION.

This label cautions to use only hydraulic fluid. (#199230)

NOTICE

GREASE POINT

This label indicates a lubrication point. (#199200)

Protecting Yourself

- Always wear protective goggles while splitting wood to protect your eyes from possible thrown bits of wood.
- Wear shoes with non-slip treads when using your DR 20-Ton WOOD SPLITTER. If you have safety shoes, we recommend wearing them. Do not use the machine while barefoot or wearing open sandals.
- Wear long pants while splitting wood.
- Avoid wearing loose clothing or jewelry, which might be caught on the splitter's moving parts.
- Use hearing protection or earplugs to protect your hearing.
- We recommend wearing snug-fitting work gloves while splitting wood.

Operating the Machine Safely



WARNING! The items listed in this section will help you keep your DR 20-Ton WOOD SPLITTER running smoothly and, most importantly, prevent injury to yourself or others. Please review them carefully before starting your machine.

- To be safe, do not operate the machine near children or pets, and never allow children to operate the splitter.
- Keep your hands and feet clear of the splitting area while the push block is in motion.
- ALWAYS shut off the engine and remove the spark plug wire before adjusting the machine. If you have to stop to remove any debris from the machine, ALWAYS retract the ram and disconnect the spark plug wire first.
- The exhaust area on the engine becomes very hot with use. Allow the engine to cool before doing maintenance or making adjustments.
- Keep combustible substances away from the engine when it is hot.
- Use the machine only in daylight or good artificial light.
- Do not use in wet or slippery conditions.
- ALWAYS OPERATE THE SPLITTER FROM THE OPERATOR ZONE. (*Figure 19*) Never straddle or climb over the wood splitter at any time.
- Use only your hands to operate the splitter controls.
- Do not place your hands at pinch points where they can get caught between a log and the wedge, push block, or log cradle.
- Do not put any part of yourself, your clothing, or your personal protective equipment into a crack in a log that is being split; it might close suddenly with great force.

- Never split anything other than logs.
- Always cut the ends of the log to be split, as squarely as possible.
- Never split more than one log at a time unless the ram has been fully extended and a second log is needed to complete the split of the first log.
- Do not handle logs by their ends when you position them on the splitter.
- Do not put anything between the log cradle and the side of a log; logs spread as they are forced against the wedge.
- Do not move or reposition the wood splitter with the motor running.
- Do not, under any conditions, remove, bend, cut, fit, weld, or otherwise alter standard parts on the DR 20-Ton WOOD SPLITTER. Modifications to your machine could cause personal injuries and will void your warranty.
- While using the DR 20-Ton WOOD SPLITTER, don't hurry or take things for granted.
- Never team up with another person to operate the wood splitter controls – this is a one person job.
- Never allow people who are unfamiliar with these instructions to use the DR 20-Ton WOOD SPLITTER.
- Never leave the wood splitter unattended with its motor running.
- Do not operate the machine when under the influence of alcohol or medication.
- Always make certain nuts & bolts are tight to assure a safe working condition.



Safety with Gasoline-Powered Machines



WARNING! The items listed in this section will help you keep your DR 20-Ton WOOD SPLITTER running smoothly and, most importantly, prevent injury to yourself or others. Please review them carefully before starting your machine.

- Do not run the engine in an enclosed area or without proper ventilation.
- Store all fuel in containers specifically designed for this purpose.
- Fill the gasoline tank outdoors with the engine off. Don't handle gasoline if you or anyone nearby is smoking, or if you are near anything that could cause the gasoline to ignite or explode.
- If you spill gasoline, do not attempt to start the engine. Move the machine away from the area of the spill and avoid creating any source of ignition until the gas vapors have dissipated. Wipe up any spilled fuel to prevent a fire hazard and properly dispose of the waste.
- Allow the engine to cool completely before storing in any enclosure. Never store the machine near an open flame or spark with gasoline in the tank.
- Do not change the engine governor settings or modify the engine speed.

Hydraulic Safety



WARNING! The items listed in this section will help you keep your DR 20-Ton WOOD SPLITTER running smoothly and, most importantly, prevent injury to yourself or others. Please review them carefully before starting your machine.



WARNING! Escaping pressurized fluid from hydraulic system leaks can have enough force to penetrate skin and cause serious injury or death.

Hydraulic fluid can remain highly pressurized while the splitter motor is off.

- Never use your hand or any part of your body to check for hydraulic system leaks while the system is pressurized.
- Get professional medical help at once if hydraulic oil penetrates anyone's skin.
- Always release residual energy from pressurized hydraulic fluid and allow the fluid to cool before doing any maintenance or repair work on the log splitter.

- Inspect hydraulic hoses every day – check for worn, frayed, kinked, and cracked areas.
- Replace any damaged or worn hoses.
- Periodically check for hydraulic leaks by placing a sheet of cardboard under the splitter while the system is running.
- Please follow these steps to depressurize system and release residual hydraulic energy before starting any repairs.
 1. Shut off splitter motor and disconnect the spark plug wire.
 2. Move control valve handle back and forth, from one limit of travel to the other, at least four times and holding the valve for three seconds at each limit of travel. The ram should not move during the 4th cycle.
 3. Call **1(800) DR-OWNER (376-9637)**, or a qualified hydraulic mechanic, to replace worn components or for assistance.
- Do not make any adjustments to the pressure relief valve.
- Never remove cap from the hydraulic tank while motor is running or while tank is still warm after motor is shut off. Hot pressurized fluid can cause serious injury, so wait for hydraulic tank to cool before removing cap.

Important! Use only DR replacement connectors, valves, or fittings on your machine. They have been thoroughly tested and proven for many hours of use.

A Note to All Users

Under California law, and the laws of some other states, you are not permitted to operate an internal combustion engine using hydrocarbon fuels without an engine spark arrester. All DR 20-Ton WOOD SPLITTERS shipped to California and Washington State are provided with spark arresters. Failure of the owner / operator to maintain this equipment in compliance with state regulations is a misdemeanor under California law and may be in violation of other state and/or federal regulations. Contact your local fire marshal or forest service for specific information in your area.

Additional Information and Potential Changes

Country Home Products, Inc. reserves the right to discontinue, change, and improve its products at any time without notice or obligation to the purchaser. The descriptions and specifications contained in this manual were in effect at printing. Equipment described within this manual may be optional. Some illustrations may not be applicable to your machine.

Chapter 3: Setting Up Your DR 20-Ton WOOD SPLITTER

SPLITTER

This chapter outlines a few simple steps you will need to follow to set up your new machine before you use it. It may be helpful to familiarize yourself with the controls and features on your splitter by reviewing the picture below before beginning the steps outlined in this chapter.

DR 20-Ton WOOD SPLITTER Controls and Features

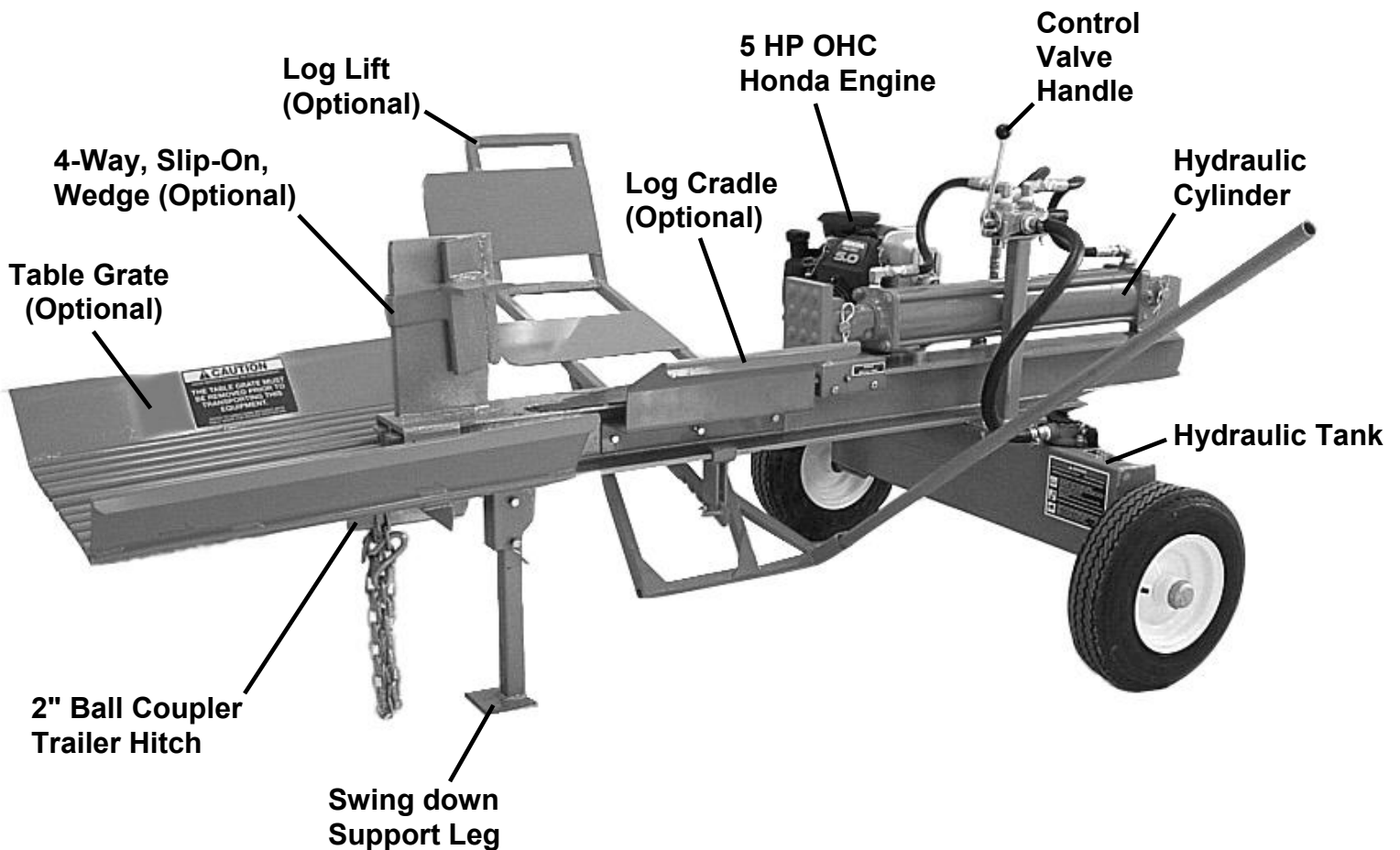

Figure 1

Unpacking the Splitter and Installing the Wheels

The DR 20-Ton WOOD SPLITTER is shipped from the factory with the wheels dismounted from the axles. The following instructions will detail how to unpack the machine and assemble the wheels to the axles prior to use.

Tools & Supplies Needed:

- Flat blade screwdriver
- Pliers
- Hammer
- Knife
- Gloves
- Eye protection
- Metal shears

Parts supplied in the plastic bag tied to the large hydraulic cylinder:

- (2) Slotted Retaining Nuts
- (2) Cotter Pins
- (2) Hub Caps

Two wheels with inner and outer bearings are strapped to the shipping pallet and pre-lubricated.



WARNING! Always wear eye protection when cutting the banding. The banding may have a lot of tension on it and may snap, striking you when cut. Always stand to one side when cutting the band.



WARNING! Always stabilize the splitter on flat terrain before attempting to unpack and install the wheels.

1. Stand to one side and cut the banding.
2. Remove the top of the carton. Separate the stapled vertical cardboard ends from the pallet to access the pallet straps. The staples are sharp so be careful.
3. Pry off the fasteners and cut any ties holding the splitter to the pallet.
4. Cut the straps holding the wheels to the pallet.

Note: The rear axle of the splitter has been raised to allow for installation of the wheels while the unit remains on the pallet.

5. With the valve stem facing out, slide the wheel on the axle, making certain the inside and outside bearings remain seated in place in the wheel hub (*Figure 2*).

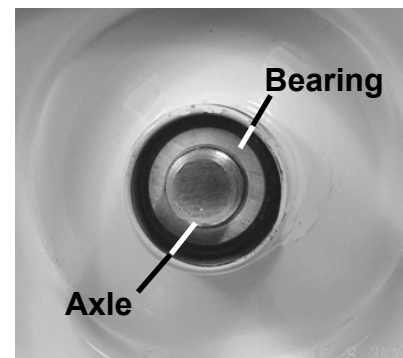

Figure 2

6. Install the retaining nut by hand. To tighten the nut, insert a screwdriver blade into a slot on the nut and tap gently with a hammer (*Figure 3*) until the nut is seated firmly against the bearing. Use care not to damage the axle threads. A slot in the nut must be aligned with the cotter pin hole in the axle. Either tighten slightly or loosen to align a slot with the hole. Check to be sure that the wheel spins freely.
7. Insert the cotter pin through the aligned slot and the hole in the axle (*Figure 4*).
8. Bend the top of the cotter pin over to retain it in the assembly (*Figure 4*). Tap the hubcap into place on the wheel hub.
9. Repeat steps 5 through 8 for the second wheel.
10. Do not discard your pallet and packaging material until you are fully satisfied with your machine.



Figure 3

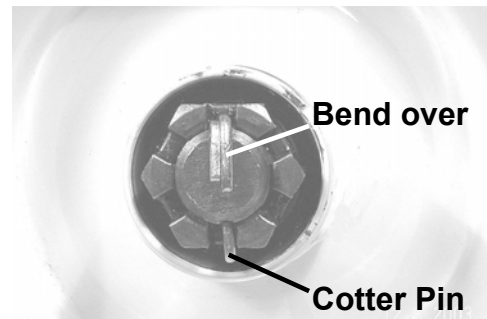



Figure 4

Check the Tire Pressure

There should be 60 psi in each tire.

Log Cradle Installation (Optional)

The following procedure includes all of the steps necessary for the installation of the optional Log Cradle on the DR 20-Ton WOOD SPLITTER.

 **WARNING!** Before performing any maintenance procedure, stop the engine and disconnect the spark plug wire.

Tool Needed:

- 9/16" wrench or socket
1. Mount the Log Cradle on the operators side of the wood splitter (*Figure 5*) and the Log Cradle retaining panel on the opposite side of the H-beam using the three 3/8" bolts and nuts. Tighten the bolts using the 9/16" socket.

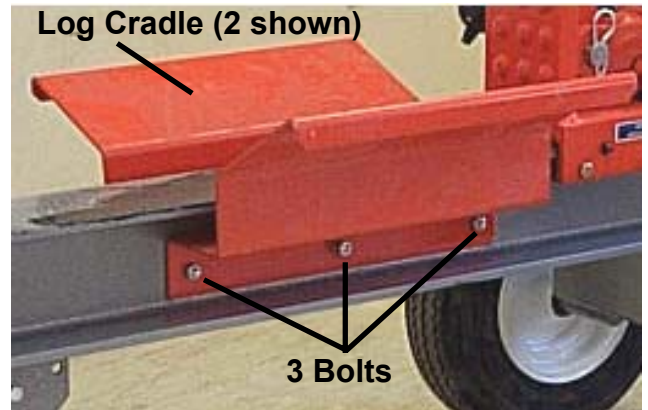

Figure 5

Manual Log Lift Installation (Optional)

The following procedure includes all of the steps necessary for the installation of the optional lever-action Manual Log Lift (*Figure 6*) on the DR 20-Ton WOOD SPLITTER.

Tools Needed:

- 1/2" wrench or socket
 - 9/16" wrench or socket
1. If the optional Log Cradle is employed, remove the three bolts that hold it on (*Figure 5*).
 2. Replace the Log Cradle retaining panel with the Log Lift mounting plate, then re-insert and tighten the three bolts and nuts. See *Figure 7* on page 13.

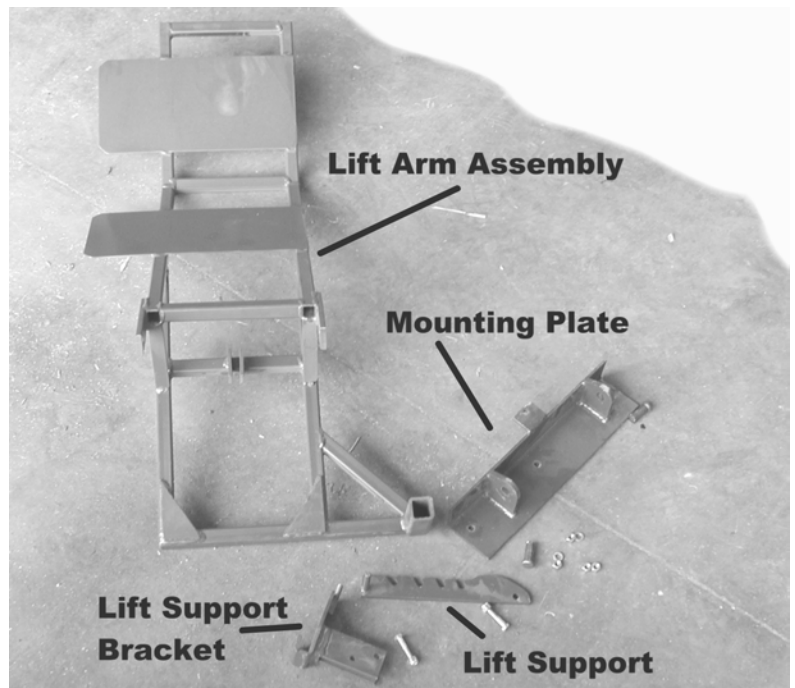

Figure 6

- Hook the Lift Support Bracket over the lower edge of the H-beam frame on the Operator's side and insert the bracket's threaded rod through the tab that extends down from the mounting plate (Figures 7 & 8). Secure with a nut using a 9/16" socket.

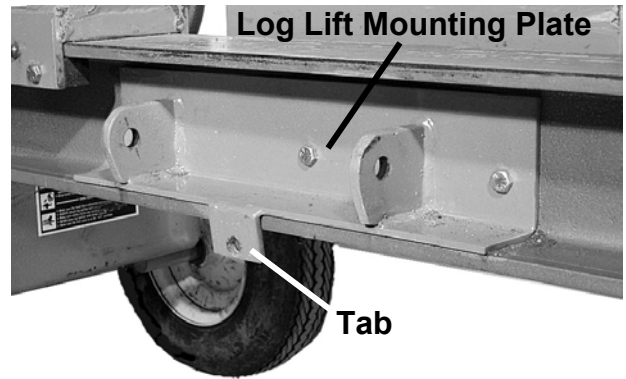

Figure 7

- Bolt left end of the multi-position Lift Support into the bracket on the Lift Arm Assembly's crosspiece using 5/16" bolts and 1/2" socket or wrench, making sure that the slots in the Lift Support face down (Figure 9).
- Attach the Lift Arm Assembly to the Mounting Plate using two retaining pins and spring clips (Figure 10).
- Hold the Lift Support up between the arms of the Lift Support Bracket and install a 5/16" bolt through the lower set of holes in the bracket below the right end of the Lift Support and tighten with a 1/2" socket (Figure 9).

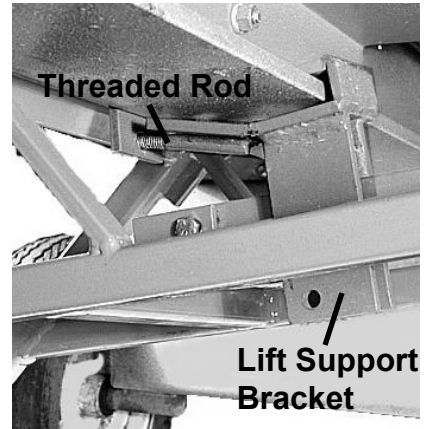

Figure 8

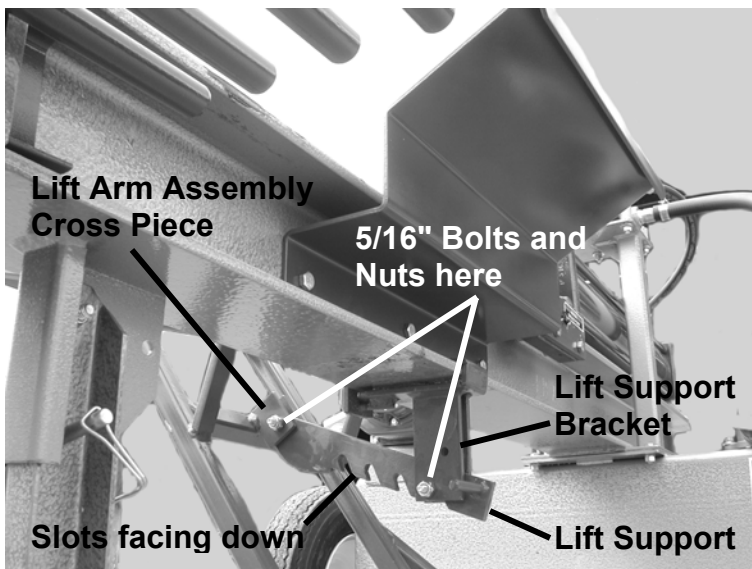

Figure 9

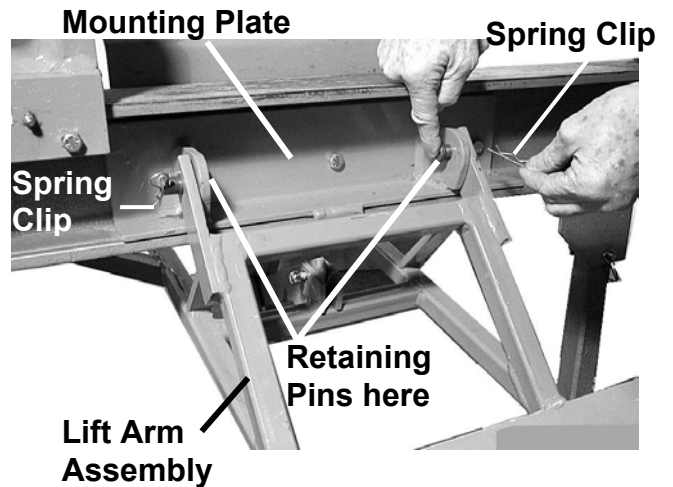

Figure 10

! WARNING! Always remove the Log Lift before transporting the splitter and never let anyone ride on the Log Lift.

Table Grate Installation (Optional)

The following procedure is for the installation of the optional Table Grate (*Figure 11*) on the DR 20-Ton WOOD SPLITTER.

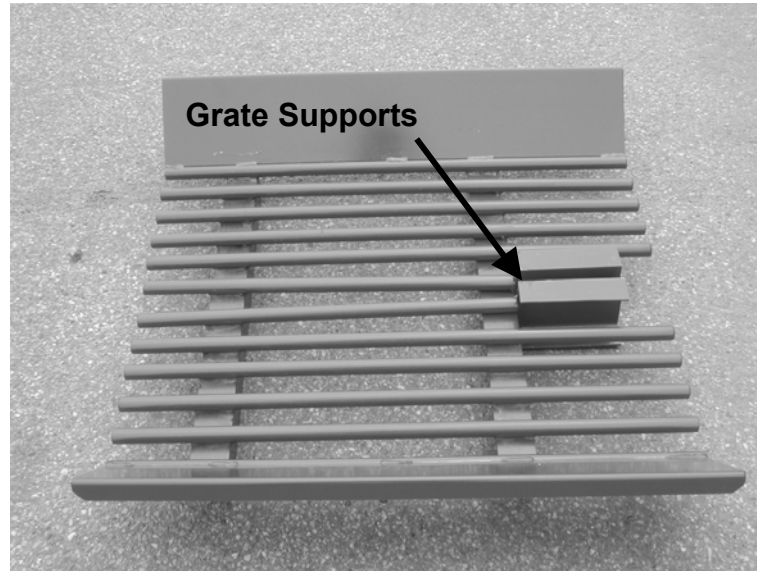

Figure 11

The tubular steel Table Grate installs behind the splitting wedge by simply sliding the box-shaped grate supports into the open end of the wood splitter frame (*Figure 12*). This enables convenient repositioning for the second pass on large pieces. Wood chips and debris will fall through the grate, providing a cleaner finished product.

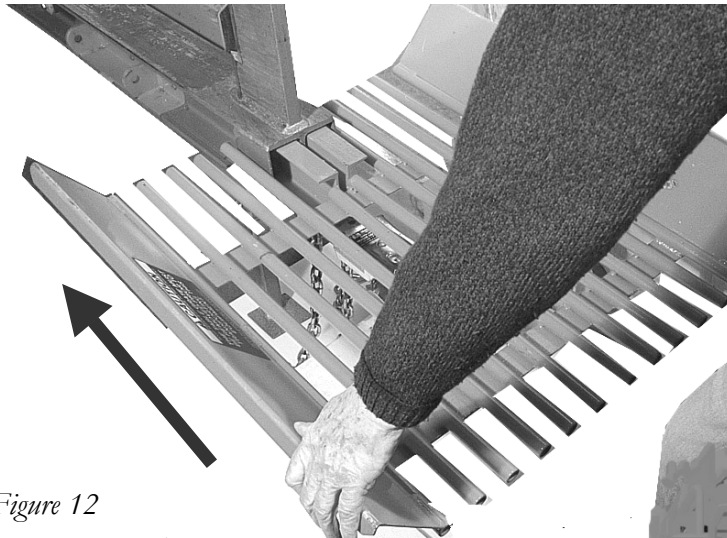

Figure 12

! WARNING! Always remove the Table Grate before transporting the splitter.

Four-way, Reversible, Slip-on Wedge Installation (Optional)

The following procedure is for the installation of the optional Four-Way Wedge (*Figure 13*) for the DR 20-Ton WOOD SPLITTER.

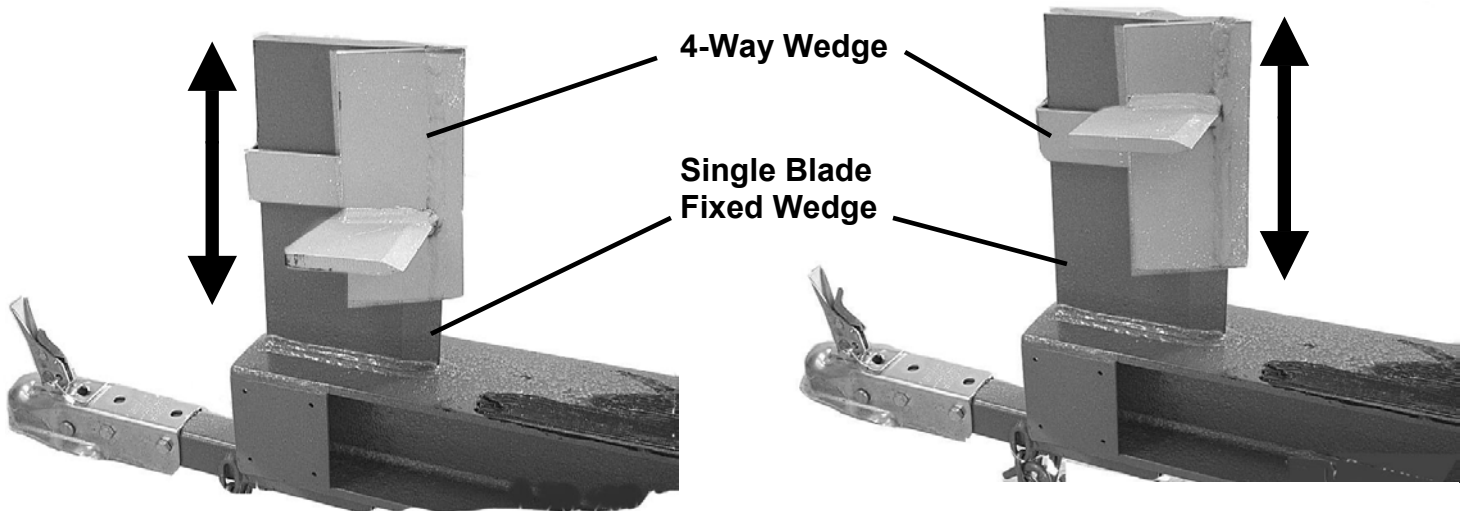

Figure 13

- Each DR 20-Ton WOOD SPLITTER has a permanently installed, 12 " single-blade, fixed wedge. The fixed wedge splits logs into two pieces.
- The fixed wedge also serves as a mounting for the optional Four-way Wedge (*Figure 13*).
- The optional Four-way Wedge will split a log (up to 24 inches in diameter) into 4 pieces on each push block cycle.
- To vary the size of the resulting split pieces of wood, simply turn the Four-way Wedge over and slip it back on the fixed wedge (*Figure 13*).

Important! Do not use a slip-on wedge with logs that have more than one knot or that have twisted grain.



WARNING! Always remove the Slip-on Wedge before transporting the splitter.

Transporting the Splitter



WARNING! NEVER move the wood splitter with the engine running.



WARNING! Do not rely on the Log Lift support to keep the Log Lift raised while transporting the wood splitter.

1. Remove the optional Four-Way Wedge, Table Grate, Log Lift (see Chapter 3) and transport them separately in the tow vehicle.
2. Make sure there are no loose parts or debris on the wood splitter that will fall off while the machine is being towed.
3. Never tow the wood splitter with a log on it.
4. Make sure the wood splitter's 2" ball coupler is firmly attached to the 2" ball on the tow vehicle hitch:
 - a.) Raise hitch latch to the unlocked position (*Figure 14*).
 - b.) Place the wood splitter hitch onto the 2" ball of the tow vehicle's trailer hitch.
 - c.) Lower the hitch latch into the locked position and secure with locking pin (*Figure 14*).
6. Make sure that the safety chains on the wood splitter's hitch are securely attached to your tow vehicle, with sufficient slack to allow for turning.
7. Make sure the front swing-down support leg is retracted and pinned up before transporting the wood splitter.

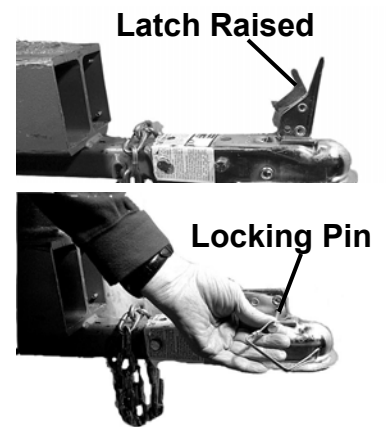

Figure 14

Towing Safety

- Never allow anyone to ride on the wood splitter.
- Never transport anything on the wood splitter.
- Obey local, state, and federal regulations when you tow the wood splitter on public roads and highways.

Note: Some states may require the wood splitter to be registered with the State Department of Motor Vehicles.

- Fenders and light kits, required in some states, are available from Country Home Products as optional equipment.
- Do not exceed 30 MPH while towing the wood splitter.
- Towing the wood splitter can affect handling:
 - The wood splitter might track at an angle the tow vehicle.
 - The wood splitter can turn tighter than the tow vehicle does.
- Never back up the tow vehicle with the wood splitter attached. The wood splitter can jackknife, causing damage to itself and/or the tow vehicle.
- Long distance towing is not recommended. The wood splitter does not have springs to absorb road shock. Extended towing can cause unnecessary wear.

Checking the Engine Oil and Adding Gasoline

The DR 20-Ton WOOD SPLITTER is shipped with the engine oil already added.

Important! To get an accurate reading when checking the engine oil; the machine should be on a level surface.

Capacities	
Honda 5.0 HP OHC Engine	SAE 10W-30W HD, .61 US qt. (0.58 L)
Gasoline Tank	Unleaded gasoline, .53 US gal. (2 L)

Tip: To avoid confusion, we recommend leaving the caps on the fuel and engine oil fills and only removing one cap each time when you are ready to pour gasoline or oil into the correct fill.

Use only SAE 10W-30W high detergent oil. Other types of oil could cause problems operating your machine. Please refer to your engine owner manual for detailed oil information.

1. To check the engine oil level, remove the oil filler cap/dipstick and wipe it clean.

2. Insert the oil filler cap/dipstick into the oil filler neck (*Figure 15*), but do not screw it in.

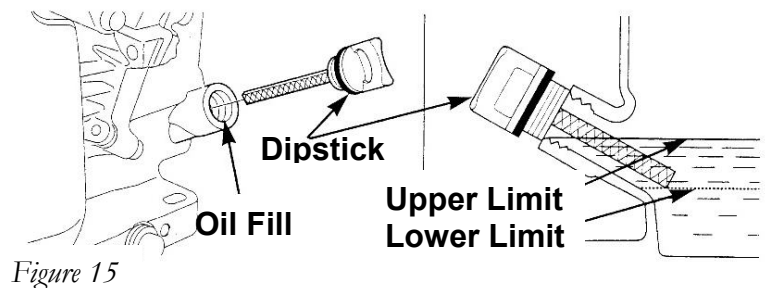

- Remove the dipstick and check the oil level. If the oil level is near or below the lower limit mark on the dipstick, add SAE 10W-30W high detergent oil (recommended by the engine manufacturer) to the upper limit mark (bottom edge of the oil fill hole). Be careful not to overfill (*Figure 15*).

3. Remove the fuel tank cap and add fresh, unleaded gas to the bottom of the fuel level limit in the neck of the fuel tank. Do not overfill (*Figure 16*). See your engine owner manual for more information.

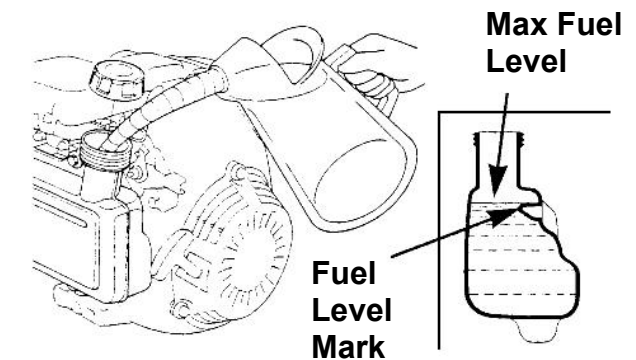

Chapter 4: Operating Your DR 20-Ton WOOD SPLITTER

This chapter covers the procedures for starting and stopping your new DR 20-Ton WOOD SPLITTER and also discusses basic operation features.

Before Starting the Engine

1. Inspect the area in which you will be working. Locate the wood splitter only on firm, level ground in a well lit and well ventilated spot. The site must be free of slippery surfaces and potentially hazardous obstacles. Also make sure there won't be people or animals in the area around the wood splitter.
2. Take out cotter pin holding the hitch support leg in the raised position, swing leg down, and insert cotter pin in the hole for the down position. (*Figure 1* on page 9)
3. Check the engine oil level every time you use the machine (See *Figure 15* on page 17).
4. Check the gasoline level (*Figure 16* on page 17).
5. Check the hydraulic fluid level. See page 26.

Starting

1. When starting a cold engine; pull the choke rod (*Figure 17*) to the Closed position.
2. Move the throttle lever (gray) up from the Stop position to about 1/3 of the way toward the Fast position (*Figure 18*).
3. Grasp the recoil starter handle and slowly pull until you feel resistance. Let the cord retract a little bit, then pull the cord rapidly to start the engine. One or two pulls usually starts the DR 20-Ton WOOD SPLITTER.
4. After the engine starts, return the choke to the Open (Run) position (*Figure 17*).
5. Allow the engine to run at idle for 10 to 15 minutes to let the hydraulic fluid warm up.
6. For best engine performance, it is recommended the engine be operated with the throttle in the Fast position (*Figure 18*).
7. To stop the engine, move the throttle to the Slow position allowing the engine to idle, then move the lever to Stop position.

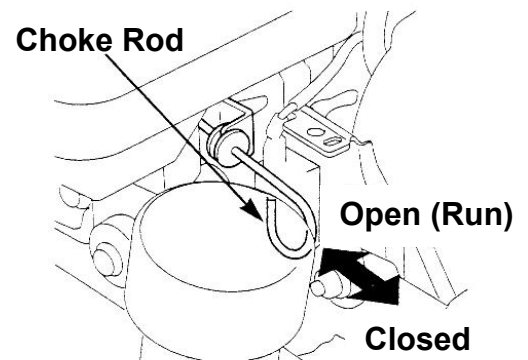

Figure 17

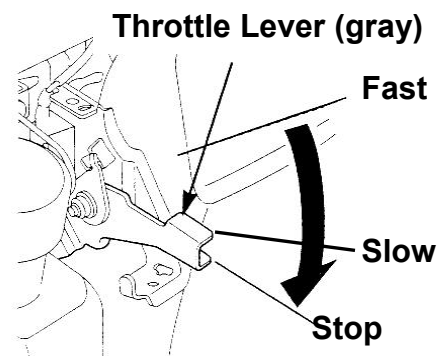

Figure 18

Splitting Safety

The DR 20-Ton WOOD SPLITTER has a push block with 20 tons of force and a 13-second cycle time.

Note: Always be sure to stand inside the **Operator Zone** to run the wood splitter (*Figure 19*). This is the area between the hydraulic tank and the optional Log Cradle. Never operate the wood splitter from anyplace else.

- Handle logs only from the sides, never by the ends.
- For best splitting results, place log on the beam with butt end toward hydraulic cylinder push block.
- Be very careful to keep arms and fingers away from the wedge and push block.
- Keep hands and fingers clear at **all** times. Many wood splitting accidents happen on the return portion of the stroke.
- Do not put any part of your body within the splitting area. Use a stick if you need to remove debris from the splitting area.

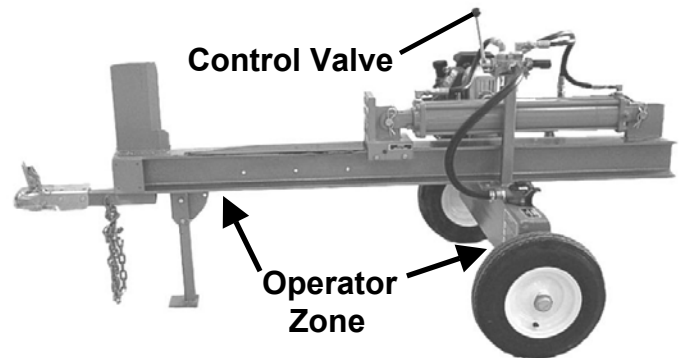

Figure 19

Loading and Wedge Positioning

1. The optional Four-Way Wedge can be installed with either end up. The installed position determines height of split cross pieces (*Figure 13* on page 15).
2. **Optional Manual Log Lift operation:** (*Figure 6* on page 12)
 - a.) With the lift fully lowered, go around the wood splitter and roll a log up to 200 lbs. MAX onto the lifting platform (*Figure 1* on page 9).
 - b.) Return to the “Operator Zone” and pull back on the Log Lift handle (*Figure 1*) to raise the lift until the log rolls onto the splitter H-beam. The Lift Support will engage in multiple positions as the Log Lift is raised (*Figure 9* on page 13).
 - c.) Keep lift raised until log is securely held between push block and wedge.
 - d.) Pull up and hold the support release while lowering Log Lift Handle.

Operating the Wood Splitter

1. To activate the control valve – push the handle forward and hold.

Note: The hydraulic control is a single handle valve (*Figure 20*). The Push Block travels forward only while valve handle is held in the forward position. The cylinder automatically completes return stroke when valve handle is pushed back to the locked (detent) position and released.

2. Put one hand on top of log, in the middle, to keep it steady until the log is held firmly between the Push Block and the wedge – then remove your hand from the log.
3. Keep holding the valve handle forward until the split pieces of the log fall away or Push Block reaches full extension, one or two inches from the wedge.

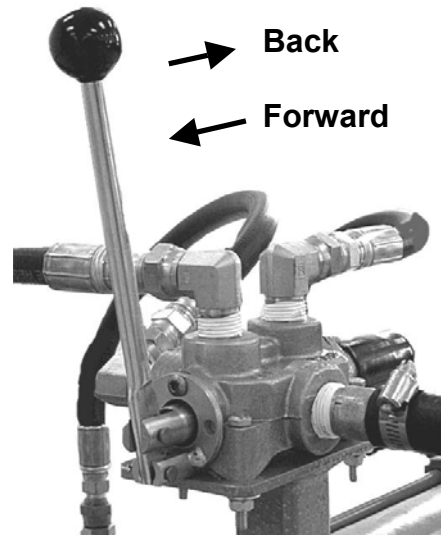

Figure 20

Note: The DR 20-Ton WOOD SPLITTER uses a two-stage hydraulic pump that normally moves the Push Block at high speed with low force and will shift automatically to low speed and high force when the wood splitter encounters more resistance. This shift in speed may occur two or three times while splitting some logs. If the two-stage hydraulic pump stays in one stage all the time, call **1(800) DR-OWNER (376-9637)** for assistance.

4. Before starting the return stroke, let the hydraulic system recover by moving the valve handle to the neutral position (straight up) for a moment.
5. Make sure nothing will interfere with the Push Block while it retracts.
6. Press the valve handle backward into the locked (detent) position and let go. The Push Block will return by itself.
7. The valve handle will stay in the locked position until the Push Block is fully retracted.

Note: To stop the Push Block or reverse direction:

- During the forward stroke, release the control valve handle.
- During the return stroke, pull the control valve handle forward to release it from the locked (detent) position.
- Operate the hydraulic control valve smoothly. Allow a short pause when reversing directions, then press lever firmly in direction you need to go. Rapidly or forcefully moving the control valve lever in either direction will cause the system to wear prematurely.

Chapter 5: Maintaining the DR 20-Ton WOOD SPLITTER

Regular maintenance is the way to ensure the best performance and long life of your splitter. Please refer to this manual and the engine owner manual for maintenance procedures. Service intervals listed in the checklist below supercede those listed in the engine owner manual.

 **WARNING!** When performing any maintenance, you must first shut off the engine, disconnect the spark plug wire, make sure the hydraulic system is depressurized and the fluid has cooled. Read the "Safety Considerations" section of this manual before performing any repairs or maintenance.

Regular Maintenance Checklist

Note: Service intervals shown are considered maximum under normal operating conditions. Increase frequencies under extremely dirty or dusty conditions.

Procedure	Before Each Use	Every 20 Hours	Every 50 Hours	Every 100 Hours	Every 200 Hours or Annually
Check Engine Oil Level	▲				
Check Hydraulic Fluid Level	▲				
Lubricate Push Block and H-beam	▲				
Check Wedge(s) for sharpness	▲				
Check Hydraulic Hoses for wear, fraying, kinking or abraded areas	▲				
Check the general condition of the splitter, e.g.; nuts, bolts, welds etc.	▲				
Check Tire Pressure		▲			
Clean Engine Air Filter		▲			
Change Engine Oil Note: 1 st time after 5 hours of operation		▲			
Change Hydraulic Fluid Note: If the hydraulic fluid becomes contaminated, change it immediately.					▲
Change Hydraulic Fluid Filter Note: 1 st time after 20 hours of operation, or if the pressure gauge indicates "Service Filter" (red area).			▲		
Clean Engine Exterior & Cooling Fins		▲			
Replace Spark Plug				▲	
Replace Engine Air Filter				▲	

Lubrication

Your DR 20-Ton WOOD SPLITTER was lubricated at the Factory. The operator needs to provide engine lubrication and lubricate the Push Block H-Beam periodically.

Tools & Supplies Needed:

- #2 Lithium Grease
- 9/16" wrench

! WARNING! Before performing any maintenance procedure, stop the engine and disconnect the spark plug wire.

1. The Push Block should be lubricated daily to reduce wear on the H-Beam and sides. Use #2 Lithium grease on the fittings, one on each side (*Figure 21*).

Note: Replace the Push Block Wear Plates (one on each side) if the Push Block can be raised more than 1/4" off the H-Beam. Use a 9/16" wrench to remove the retaining bolts (*Figure 21*).

2. The top of the H-Beam should be lubricated daily by coating it with #2 Lithium grease.
3. The wheel bearings should be lubricated (hand packed) with #2 Lithium grease annually or after any trip longer than 50 miles. Refer to section "Unpacking the Splitter and Installing the Wheels" on pages 10 & 11. Perform steps 5 thru 8 in the reverse order to remove the wheels. Slide out the inner and outer bearings and hand pack them with the #2 Lithium grease. Re-insert the bearings and replace the wheels per steps 5 thru 8 on pages 10 & 11.

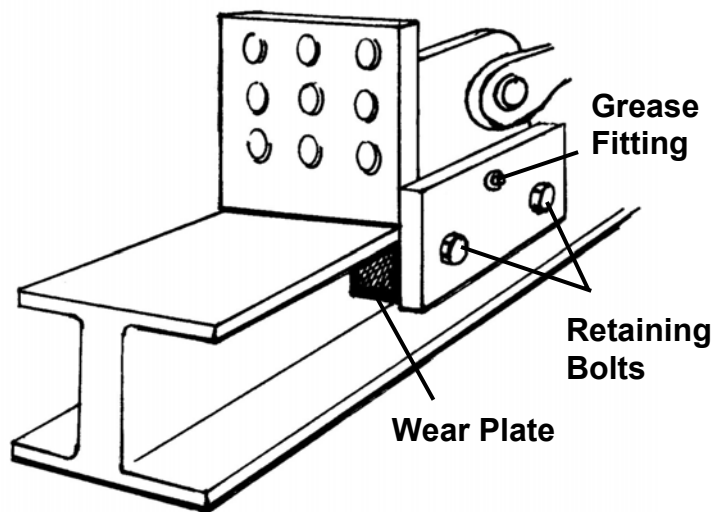

Figure 21

Removing and Replacing the Engine Oil

! WARNING! Before performing any maintenance procedure, stop the engine and disconnect the spark plug wire.

Tools & Supplies Recommended:

- 1/2" wrench
- SAE 10W-30W HD, .61 US qt. (0.58 L)
- CHP Liquid Vac Oil Drainer, item # 16145 (Optional)

Note: Drain the oil when the engine is warm. Warm oil drains quickly and completely.

1. Position a suitable oil receptacle under the engine oil drain and remove the engine oil filler cap (*Figure 22*).
2. Remove the engine oil drain plug using the 1/2" wrench (*Figure 22*).
3. Allow the used oil to drain completely, then reinstall the drain plug with washer and tighten securely.
4. Replace the engine oil using SAE 10W-30W HD oil. See page 17.

Optional Method

1. Remove the engine oil Fill Cap and vacuum the oil from the engine through the oil fill tube using the recommended CHP oil drainer.
2. Replace the engine oil using SAE 10W-30W HD oil. See page 17.

Note: If the oil is not to be reused, be sure to use environmentally safe disposal procedures in the disposing of the used oil.

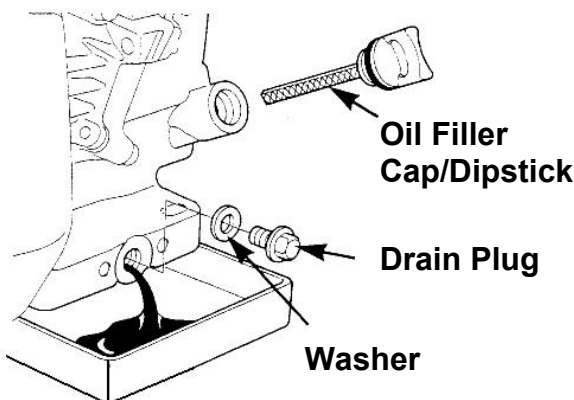



Figure 22

Important! Be certain to fill with oil before starting the engine. See Page 17.

Removing and Replacing the Hydraulic Fluid and Filter

 **WARNING!** Before performing any maintenance procedure, stop the engine and disconnect the spark plug wire.

 **WARNING!** Escaping pressurized fluid from hydraulic system leaks can have enough force to penetrate skin and cause serious injury or death. Hydraulic fluid can remain highly pressurized while the splitter motor is off.

- Never use your hand or any part of your body to check for hydraulic system leaks while the system is pressurized.
- Get professional medical help at once if hydraulic oil penetrates anyone's skin.
- Always release residual energy from pressurized hydraulic fluid and allow the fluid to cool before doing any maintenance or repair work on the log splitter.

Important! Use only Rando 46 (Texaco) hydraulic fluid or equivalent.

Tools & Supplies Needed:

- Rando 46 (Texaco) 4.5 gallons (17L)
- Pipe wrench
- Screwdriver
- Filter element, 198980

1. With the engine stopped, release any residual hydraulic pressure by moving the control lever back and forth a couple of times.
2. Remove the filler plug and then remove the filter element inside the filler opening (*Figure 23*).
3. Place a suitable container under the drain elbow of the hydraulic fluid tank (*Figure 24*).
4. Loosen the pump hose clamp from the pump hose (*Figure 24*), at the pump end, using the screwdriver. Then remove the hose from the nipple.
5. While holding the hose up, turn the tank drain elbow 180° counterclockwise using the pipe wrench and then lower the hose into the fluid container allowing the fluid in the tank to drain completely (*Figure 24*).
6. Turn the drain elbow 180° clockwise, reattach the hose to the pump connection nipple and tighten the clamp.

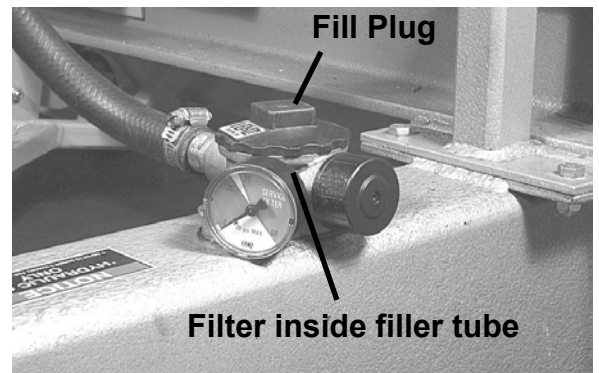

Figure 23

7. Fill the hydraulic tank with fresh fluid to about 1" from the top of the tank.
8. Insert a new filter element in the filler opening and replace the filler cap.
9. Start the splitter engine and operate the ram back and forth a couple of times to bleed the air from the hydraulic system.
10. The pressure gauge should now indicate a pressure in the "green" area of the pressure gauge dial (0-25 psi).
11. Recheck and adjust the hydraulic fluid level per step 7.

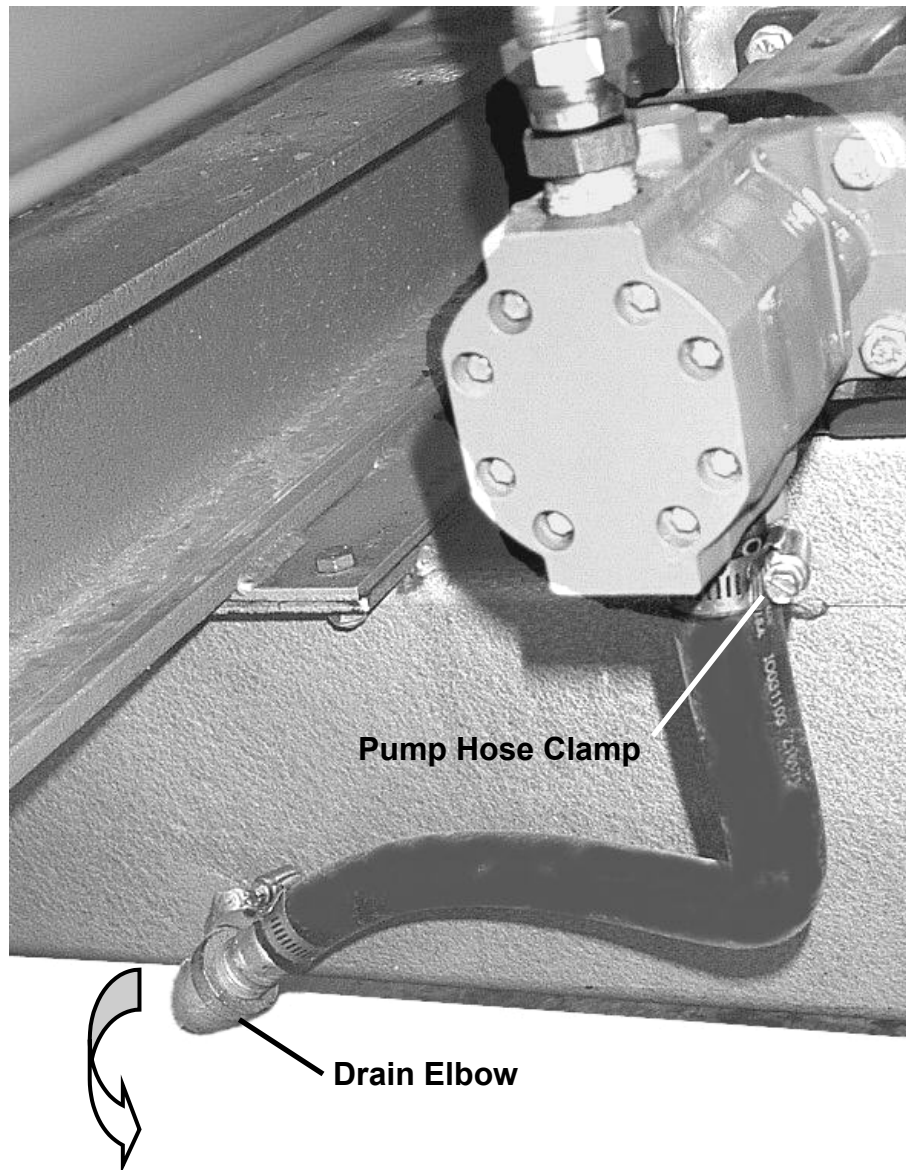

Figure 24

Removing and Replacing the Hydraulic Hoses

⚠ WARNING! Before performing any maintenance procedure, stop the engine and disconnect the spark plug wire.

⚠ WARNING! Escaping pressurized fluid from hydraulic system leaks can have enough force to penetrate skin and cause serious injury or death. Hydraulic fluid can remain highly pressurized while the splitter motor is off.

- Never use your hand or any part of your body to check for hydraulic system leaks while the system is pressurized.
- Get professional medical help at once if hydraulic oil penetrates anyone's skin.
- Always release residual energy from pressurized hydraulic fluid and allow the fluid to cool before doing any maintenance or repair work on the log splitter.

Important! Use only Rando 46 (Texaco) hydraulic fluid and DR replacement hoses, connectors, valves, or fittings on your machine. They have been thoroughly tested and proven for many hours of use.

Tools & Supplies Needed:

- 1" wrench (fitting)
- 7/8" wrench (hose)
- Rando 46 (Texaco) hydraulic fluid (approx. 1 qt. to refill)
- Screwdriver

1. With the engine stopped, release any residual hydraulic pressure by moving the control lever back and forth a couple of times.
2. Use the 7/8" wrench to hold the high pressure hose end being replaced while loosening the fitting with the 1" wrench. (*Figure 25*)
3. Install the new hose in the reverse order.
4. To replace a low pressure hose, loosen the hose clamp with a screwdriver and slip the hose off the connector nipple.
5. Install the new hose in the reverse order.

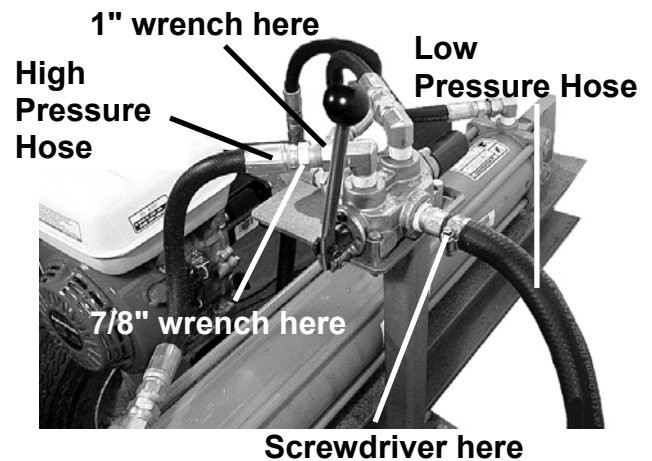

Figure 25

6. Check and adjust the hydraulic fluid to be about 1" from the top of the tank.
7. Start the splitter engine and operate the ram back and forth a couple of times to bleed any air from the hydraulic system.
8. The pressure gauge should indicate a pressure in the "green" area of the pressure gauge dial (0-25 psi).
9. Recheck and adjust the hydraulic fluid level per step 6.

Adjusting the Hydraulic Control Valve

Tools Needed:

- 7/16" wrench
- 1/8" (9mm) Hex wrench

If the hydraulic push ram will not return all the way back to its retracted position, the locked position (detent) on the right side (Operator's side) of the control valve may have to be adjusted.

1. Pull off the black protective cap (*Figure 26*) on the right side of the control valve and loosen the jam nut with the 7/16" wrench (*Figure 27*).
2. Using the Hex wrench, turn the screw on the control valve clockwise, a quarter turn at a time (*Figure 27*), until the push ram will return to its fully retracted position. Retighten the jam nut and replace the protective cap.

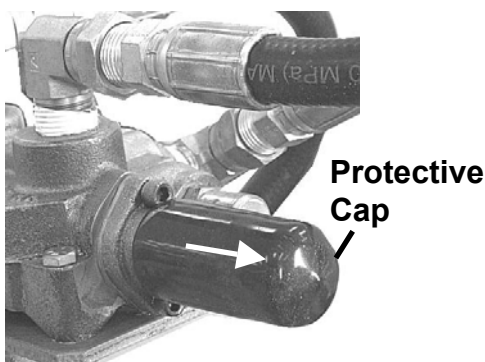

Figure 26

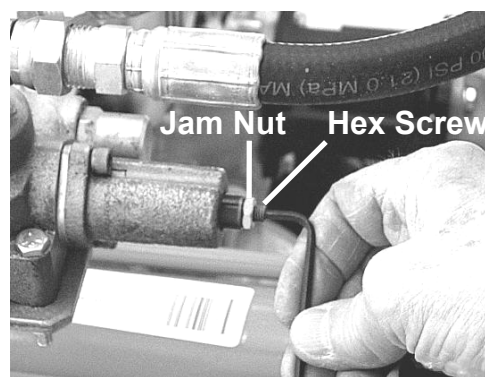

Figure 27

End of Season & Storage



WARNING! Before performing any maintenance procedure, stop the engine and disconnect the spark plug wire.

Note: Please refer to the engine owner manual for engine-specific procedures.

- Change the oil.
- If your DR 20-Ton WOOD SPLITTER will be idle for more than 30 days, we recommend using a gas stabilizer. This will prevent sediment from gumming up the carburetor. If there is dirt or moisture in the gas or tank, remove it by draining the tank. Completely fill the tank with fresh, unleaded gas and add the appropriate amount of stabilizer or gasoline additive. Run the engine for a short time to allow the additive to circulate.
- Remove the spark plug and pour about 1 ounce of motor oil into the cylinder hole. Replace the plug and pull the recoil starter rope until you feel strong resistance. This will coat the piston and seat the valves to prevent moisture buildup.
- Clean/replace the air filter.
- Clean dirt and debris from the cylinder head cooling fins, blower housing, debris screen and muffler area of the engine.

Chapter 6: Troubleshooting and Warranty

Most problems are easy to fix. Consult the troubleshooting table for common problems and their solutions. If you continue to experience problems, call Country Home Products, Inc. for support.

Troubleshooting Table



WARNING! Before performing any maintenance procedure, stop the engine and disconnect the spark plug wire.

SYMPTOM	POSSIBLE CAUSE
<i>Recoil will not pull out or is difficult to pull.</i>	<ul style="list-style-type: none"> ⇒ Check the engine oil level, the engine may be seized. ⇒ There may be an oil compression lock in the cylinder. Take out the spark plug, hold a rag over the spark plug hole and pull the recoil cord several times to blow out any oil in the cylinder. Wipe off the spark plug and reinsert it. ⇒ The recoil may be broken or jammed. Call 1(800) DR-OWNER (376-9637) for assistance.
<p><i>The engine won't start.</i></p> <p><i>(Please refer to the engine manufacturer's owner's manual for engine-specific procedures.)</i></p>	<ul style="list-style-type: none"> ⇒ Check the oil level. See page 17. ⇒ Are you using fresh, clean gas? If the gas is old, change it. Use a fuel stabilizer if you keep gas longer than one month. ⇒ Check the throttle adjustment and travel. See page 19. ⇒ Is the spark plug clean? If the spark plug is dirty or cracked, change it. If it's oily, leave it out, hold a rag over the plug hole and pull the recoil cord several times to blow out any oil in the cylinder, then wipe off the plug and reinsert it. ⇒ If your engine still won't start, call 1(800) DR-OWNER (376-9637) for assistance.

Symptom	Possible Cause
<p><i>The engine lacks power or is not running smoothly.</i></p> <p><i>(Please refer to the engine manufacturer's owner's manual for engine-specific procedures.)</i></p>	<ul style="list-style-type: none"> ⇒ Check the throttle travel. See page 19. ⇒ Is the choke pushed all the way in (Open)? See page 19. ⇒ Is the air filter clean? If it's dirty, change it following the procedure in the engine manufacturer's owner's manual. ⇒ Is the spark plug clean? If it's fouled or cracked, change it. If it's oily, leave it out, hold a rag over the plug hole and pull your recoil cord several times to blow out any oil in the cylinder, then wipe off the plug and reinsert it. ⇒ Are you using fresh, clean unleaded gas? If it's old, change it. Use a fuel stabilizer if you keep gas longer than one month. ⇒ Does your engine have the right amount of clean oil? If it's dirty, change it following the procedure in the engine manufacturer's owner's manual. ⇒ Check the oil level and adjust as needed. ⇒ If your engine still lacks power, call 1(800) DR-OWNER (376-9637) for assistance.
<p><i>Engine smokes.</i></p>	<ul style="list-style-type: none"> ⇒ Check the oil level and adjust as needed. ⇒ Check the air filter and clean or replace if needed. ⇒ You may be using the wrong oil—too light for the temperature. Refer to your Engine Manufacturer's Owner's Manual for detailed information. ⇒ Clean the cooling fins if they're dirty. ⇒ If the engine still smokes, call 1(800) DR-OWNER (376-9637) for assistance.
<p><i>Splitter wheels tracking left or right while being towed.</i></p>	<ul style="list-style-type: none"> ⇒ Check the tire pressure. There should be 60 psi in each tire.
<p><i>Push Ram will not move or is slow to respond.</i></p>	<ul style="list-style-type: none"> ⇒ The hydraulic fluid may be low. Check and adjust the level as required. See page 26. ⇒ The hydraulic fluid filter may be dirty or plugged. See page 26.

Notes

Notes

1-Year Limited Warranty

Terms and Conditions

The DR[®] 20-Ton WOOD SPLITTER is warranted for one (1) year against defects in materials or workmanship when put to ordinary and normal consumer use; ninety (90) days for any other use. The engine is warranted separately by the engine manufacturer.

For the purposes of all the above warranties, "ordinary and normal consumer use" refers to non-commercial residential use and does not include misuse, accidents or damage due to inadequate maintenance.

Country Home Products, Inc. certifies that the DR[®] 20-Ton WOOD SPLITTER is fit for ordinary purposes for which a product of this type is used. Country Home Products, Inc. however, limits the implied warranties of merchantability and fitness in duration to a period of one (1) year in consumer use, ninety (90) days for any other use.

The 1-Year Limited Warranty on the DR[®] 20-Ton WOOD SPLITTER starts on the date the machine ships from our factory. The 1-Year Limited Warranty is applicable only to the original owner.

The warranty holder is responsible for the performance of the required maintenance as defined by the manufacturer's owner's manuals. The warranty holder is responsible for replacement of normally wearing parts such as the hydraulic hoses, wear plates, and spark plug. Attachments and accessories to the machine are not covered by this warranty.

During the warranty period, the warranty holder is responsible for the machine transportation charges, if required. During the warranty period, warranty parts will be shipped by standard method at no charge to the warranty holder. Expedited shipping of warranty parts is the responsibility of the warranty holder.

SOME STATES DO NOT ALLOW LIMITATIONS ON THE LENGTH OF IMPLIED WARRANTIES, SO THE ABOVE LIMITATIONS MAY NOT APPLY TO YOU.

Country Home Products, Inc. shall not be liable under any circumstances for any **incidental or consequential damages or expenses** of any kind, including, but not limited to, cost of equipment rentals, loss of profit, or cost of hiring services to perform tasks normally performed by the DR[®] 20-Ton WOOD SPLITTER.

SOME STATES DO NOT ALLOW THE EXCLUSION OR LIMITATION OF INCIDENTAL OR CONSEQUENTIAL DAMAGES, SO THE ABOVE LIMITATIONS MAY NOT APPLY TO YOU.

Customer Service Hotline

Country Home Products, Inc.'s objective is to have 100% satisfied customers. For that reason, we operate a 6-day-a-week Technical Service Department for our Owners. You can access a Representative by dialing our TOLL-FREE Hotline at 1-800-DR-OWNER (376-9637). The sole job of our well-trained and friendly folks is to ensure that you get any help you need in a timely fashion. They are there to answer all your questions including: (1) inquiries on any of the above warranties, (2) inquiries about replacement parts, or (3) your questions regarding service, maintenance and operation.

Our Customer Service Representatives will also be happy to answer any of your questions regarding the separate warranties on all engines. However, to obtain service, repair or replacement of any engine within the time period covered by the manufacturer's limited warranty, follow the instructions and warranty information specifically pertaining to those items provided by their separate manufacturers.

THIS WARRANTY GIVES YOU SPECIFIC LEGAL RIGHTS, AND YOU ALSO HAVE OTHER RIGHTS, WHICH VARY FROM STATE TO STATE.

Daily Checklist for the DR 20-Ton WOOD SPLITTER

To help maintain your DR 20-Ton WOOD SPLITTER for optimum performance, we recommend you follow this checklist each time you use your machine.

- [] **OIL:** With the splitter on a level surface, remove the oil fill cap and check the oil level. Fill the reservoir according to the dipstick with SAE 10W-30W HD motor oil. (See page 17)
- [] **GAS:** Fill the gas tank with fresh, unleaded gasoline. See page 17.
- [] **ENGINE:** It is very important to keep the engine clean. Remove dirt and other debris from the engine cooling fins and debris guard. A dirty engine retains heat and can cause damage to internal engine components.
- [] **HARDWARE:** Check all nuts and bolts to be sure that the components are secure.
- [] **FRAME:** Check all welds to be sure that the frame is in tact and secure.
- [] **WEAR PLATES:** Make sure that the Wear Plates attached to the Push Block are firmly bolted into place. (See page 24)
- [] **GREASE:** Make sure that Push Block and the top of the H-Beam are well lubricated with grease. (See page 24)
- [] **HYDRAULIC HOSES:** Inspect the hydraulic hoses for frayed, worn, kinked, or abraded areas. Replace any damaged or worn hoses immediately. (See page 28)



COUNTRY HOME PRODUCTS, Inc.

MEIGS ROAD, P.O. BOX 25, VERGENNES, VERMONT 05491

1-800-DR-OWNER (376-9637) • www.dr-owner.com

©2004 CHP, Inc. 186501