



OPERATOR'S MANUAL

GENERAC® G10 KINETIC LOG SPLITTER



Serial No. _____

Order No. _____

Original Language

Generac Power Systems
Toll-free phone: 1-888-545-6576

WARNING

Read and understand this manual and all instructions before operating the KINETIC LOG SPLITTER.

Table of Contents

Chapter 1: General Safety Rules.....	3
Chapter 2: Setting Up The KINETIC LOG SPLITTER	7
Chapter 3: Operating The KINETIC LOG SPLITTER	9
Chapter 4: Maintaining The KINETIC LOG SPLITTER.....	12
Chapter 5: Troubleshooting	16
Chapter 6: Parts Lists and Schematic Diagrams.....	18

Conventions used in this manual

! WARNING

This indicates a hazardous situation, which, if not avoided, could result in death or serious injury.

! CAUTION

This indicates a hazardous situation, which, if not avoided, could result in minor or moderate injury.

NOTICE

This information is important in the proper use of your machine. Failure to follow this instruction could result in damage to your machine or property.

Serial Number and Order Number

A Serial Number is used to identify your machine and is located on the Serial Number Label on your machine. An Order Number is used to check and maintain your order history and is located on your packing slip. For your convenience and ready reference, enter the Serial Number and Order Number in the space provided on the front cover of this manual.

Additional Information and Potential Changes

Generac Power Systems reserves the right to discontinue, change, and improve its products at any time without notice or obligation to the purchaser. The descriptions and specifications contained in this manual were in effect at printing. Equipment described within this manual may be optional. Some illustrations may not be applicable to your machine.

Chapter 1: General Safety Rules

WARNING

Read this Safety & Operating Instructions manual before you use the KINETIC LOG SPLITTER. Become familiar with the operation and service recommendations to ensure the best performance from your machine. If you have any questions or need assistance, please contact us at 1-888-545-6576 and one of our Technical Support Representatives will be happy to help you.

Labels

Your KINETIC LOG SPLITTER carries prominent labels as reminders for its proper and safe use. Shown below are copies of all the Safety and Information labels that appear on the equipment. Take a moment to study them and make a note of their location on your LOG SPLITTER as you set up and before you operate the unit. Replace damaged or missing safety and information labels immediately.

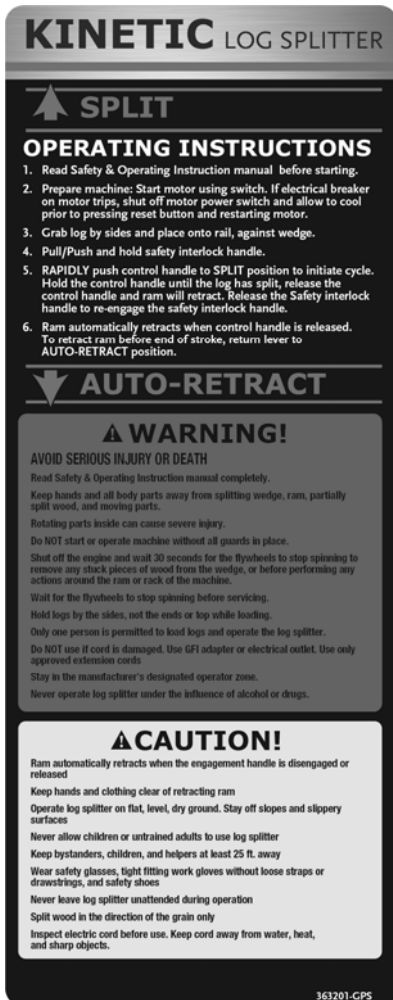

KINETIC LOG SPLITTER

 **SPLIT**

OPERATING INSTRUCTIONS

1. Read Safety & Operating Instruction manual before starting.
2. Prepare machine: Start motor using switch. If electrical breaker on motor trips, shut off motor power switch and allow to cool prior to pressing reset button and restarting motor.
3. Grab log by sides and place onto rail, against wedge.
4. Pull/Push and hold safety interlock handle.
5. **RAPIDLY** push control handle to **SPLIT** position to initiate cycle. Hold the control handle until the log has split, release the control handle and ram will retract. Release the Safety interlock handle to re-engage the safety interlock handle.
6. Ram automatically retracts when control handle is released. To retract ram before end of stroke, return lever to **AUTO-RETRACT** position.

 **AUTO-RETRACT**

⚠ WARNING!

AVOID SERIOUS INJURY OR DEATH

Read Safety & Operating Instruction manual completely.

Keep hands and all body parts away from splitting wedge, ram, partially split wood, and moving parts.

Rotating parts inside can cause severe injury.

Do NOT start or operate machine without all guards in place.

Shut off the engine and wait 30 seconds for the flywheels to stop spinning to remove any stack pieces of wood from the wedge, or before performing any actions around the ram or rack of the machine.

Wait for the flywheels to stop spinning before servicing.

Hold logs by the sides, not the ends or top while loading.

Only one person is permitted to load logs and operate the log splitter.

Do NOT use if cord is damaged. Use GFI adapter or electrical outlet. Use only approved extension cords.

Stay in the manufacturer's designated operator zone.

Never operate log splitter under the influence of alcohol or drugs.

⚠ CAUTION!

Ram automatically retracts when the engagement handle is disengaged or released

Keep hands and clothing clear of retracting ram

Operate log splitter on flat, level, dry ground. Stay off slopes and slippery surfaces

Never allow children or untrained adults to use log splitter

Keep bystanders, children, and helpers at least 25 ft. away

Wear safety glasses, tight fitting work gloves without loose straps or drawstrings, and safety shoes

Never leave log splitter unattended during operation

Split wood in the direction of the grain only

Inspect electric cord before use. Keep cord away from water, heat, and sharp objects.

363201-GPS

#36320



⚠ WARNING
PINCH POINT

#25044

Protecting Yourself and Those Around You

WARNING

This is a high-powered machine, with moving parts operating with high energy. You must operate the machine safely. Unsafe operation can create a number of hazards for you, as well as anyone else in the nearby area. Always take the following precautions when using this machine:

- Keep in mind that the operator or user is responsible for accidents or hazards occurring to other people, their property, and themselves.
 - Always wear protective goggles or safety glasses with side shields while using the Log Splitter to protect your eyes from possible thrown debris.
 - Avoid wearing loose clothing or jewelry, which can catch on moving parts.
 - We recommend wearing gloves while using the Log Splitter. Be sure your gloves fit properly and do not have loose cuffs or drawstrings.
 - Wear shoes with non-slip treads when using your Log Splitter. If you have safety shoes, we recommend wearing them. Do not use the machine while barefoot or wearing open toed sandals.
 - Wear long pants while operating the Log Splitter.
 - Use ear protectors or ear plugs rated for at least 20 dba to protect your hearing.
 - Keep bystanders at least 50 feet away from your work area at all times. Stop the motor when another person or pet approaches.
-

Safety for Children and Pets

WARNING

Tragic accidents can occur if the operator is not alert to the presence of children and pets. Children are often attracted to the machine and the splitting activity. *Never* assume that children will remain where you last saw them. Always follow these precautions:

- Keep children and pets at least 50 feet from the working area and ensure they are under the watchful care of a responsible adult.
 - Be alert and turn the machine off if children or pets enter the work area.
 - Never allow children to operate the Log Splitter.
-

Safety with Electric - Powered Machines

WARNING

Never overlook the hazards of electricity. Always follow these precautions:

- Never open the switch box or motor cover. Never attempt any electrical repairs yourself. If in doubt, consult a qualified electrician, or contact Generac Power Systems for toll-free support at: 1-888-545-6576 for help or information.
 - Never use an extension cord that is not rated for outdoor use.
 - Never operate the Log Splitter if there is an electrical hazard present.
 - Never operate the Log Splitter in wet conditions and always store under cover.
 - Never operate the Log Splitter with a damaged electrical cord or damaged extension cord.
 - Never pull on the electrical cord to move the machine.
 - Always grasp the electrical cord plug when unplugging the cord from the outlet; never pull the plug out by the cord. Make sure your fingers do not touch the metal prongs when plugging or unplugging.
 - Never operate the Log Splitter unless the electrical cord is plugged into a properly grounded GFCI protected electrical outlet, which supplies 110-120v power, and is protected by a 20-amp circuit breaker.
 - Never tamper with safety devices. Check their proper operation regularly.
 - If you are using an extension cord, keep the connection between the electrical cord and the extension cord well away from any water.
 - Never use an extension cord longer than 25 feet and smaller than 12 awg in diameter, or longer than 50 feet and smaller than 10 awg in diameter; the cord will produce a voltage drop that will prevent the motor from supplying full power and may cause damage to the motor. Use of a smaller diameter (larger awg number) extension cord could result in melting of the insulation or even create a fire.
 - Always keep the electrical cord and/or extension cord away from excessive heat, oil, and sharp objects.
-

General Safety

WARNING

Operating this Log Splitter safely is necessary to prevent or minimize the risk of death or serious injury. Unsafe operation can create a number of hazards for you. Always take the following precautions when operating this Log Splitter:

- Your Log Splitter is a powerful tool, not a plaything. Exercise extreme caution at all times. The machine is designed to split logs. Do not use it for any other purpose.
- Know how to stop the Log Splitter quickly; see “stopping the motor” in chapter 3.
- Never operate your unit on a slippery, wet, muddy, or icy surface. Exercise caution to avoid slipping or falling.
- See manufacturer’s instructions for proper operation and installation of accessories. Only use accessories approved by Generac Power Systems.
- Never use the machine without ensuring that all guards and shields are in place.
- Never, under any conditions, remove, bend, cut, fit, weld, or otherwise alter standard parts on the Log Splitter. This includes all shields and guards. Modifications to your machine could cause personal injuries and property damage and will void your warranty.
- Allow only one person to operate the Log Splitter at any time. This includes placing the log on the beam.
- If the machine should start making an unusual noise or vibration, shut off the Motor, Unplug the Power Cord, wait five minutes for machine to cool down then inspect for damage. Vibration is generally a warning of trouble. Check for damaged parts and clean, repair and replace as necessary.
- Never tamper with safety devices. Check their proper operation regularly.
- Before performing any maintenance or inspection procedure on the Log Splitter, shut off the Motor, unplug the Power Cord and wait five minutes for machine to cool down.
- Never allow people who are unfamiliar with these instructions to use the Log Splitter. Allow only responsible individuals who are familiar with these rules of safe operation to use your machine.
- Never overload or attempt to split logs beyond the recommendations listed in this manual. Personal injury or damage to the machine could result.
- While using the Log Splitter, don't hurry or take things for granted. When in doubt about the equipment or your surroundings stop the machine and take the time to look things over.
- Never operate the machine when under the influence of alcohol, drugs, or medication.
- Use the machine only in daylight.
- Stay alert for hidden hazards or traffic.
- Keep all nuts and bolts tight and keep the equipment in good operating condition.

California Proposition 65

WARNING

California Proposition 65:

- This product contains or emits chemicals known to the state of California to cause cancer, birth defects, and other reproductive harm.

A Note to All Users

No list of warnings and cautions can be all-inclusive. If situations occur that are not covered by this manual, the operator must apply common sense and operate this KINETIC LOG SPLITTER in a safe manner. Contact us at 1-888-545-6576 for assistance.

Chapter 2: Setting Up The KINETIC LOG SPLITTER

It may be helpful to familiarize yourself with the controls and features of your KINETIC LOG SPLITTER as shown in Figure 1 before beginning these procedures. If you have any questions at all, please feel free to contact us at 1-888-545-6576.

KINETIC LOG SPLITTER Controls and Features

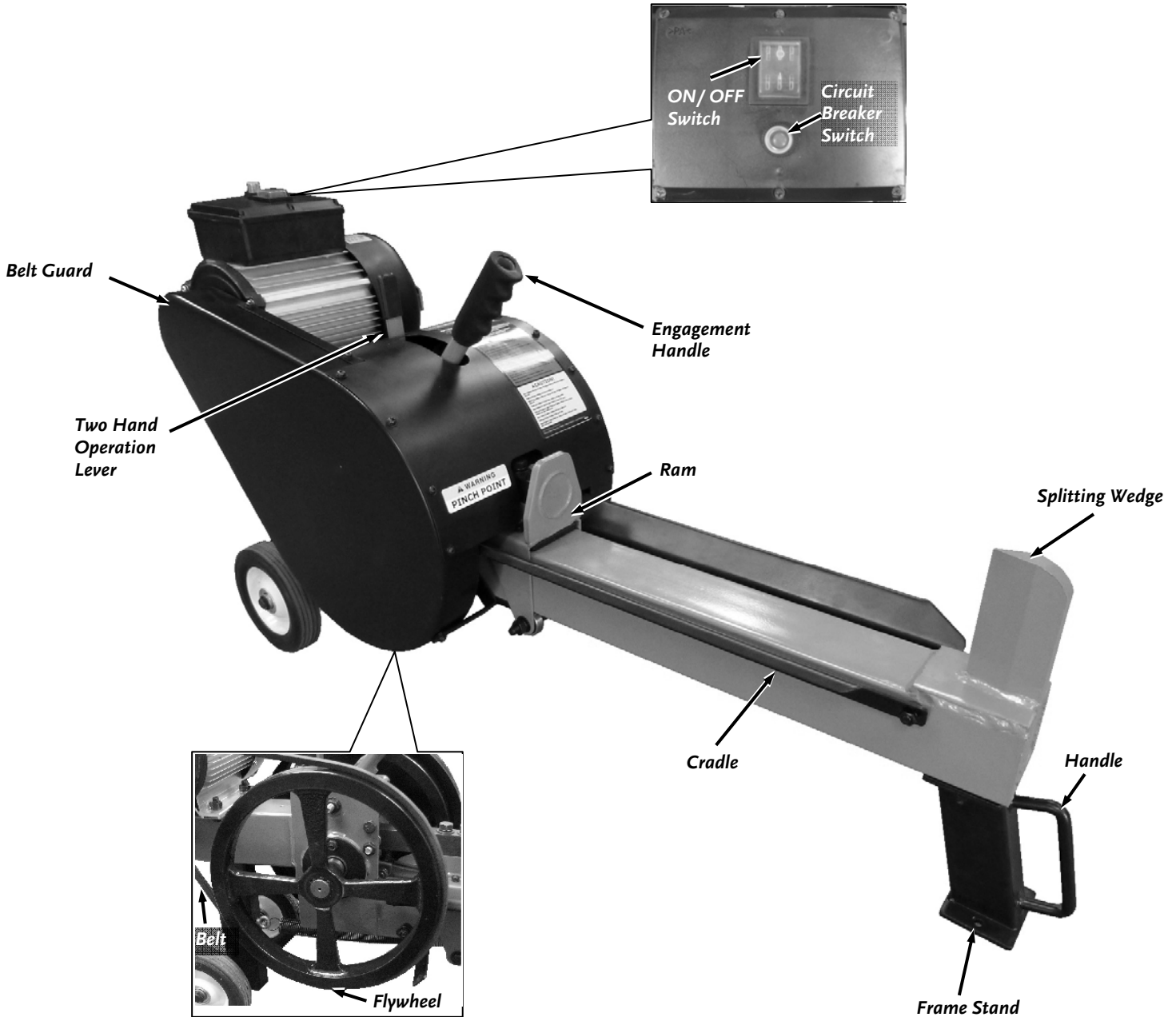

Figure 1

Specifications

HP	2
Output Torque	.025 in-lbs @ Full Load
Voltage	110
Full Load Current (Amps)	14.5
Power (Watts)	1060
Hertz	60
Phase	1
Overload Protection	Thermal Breaker
Outlet Cord	6'
Frame Gauge	3mm
Belt Size	A-1180
Flywheel Weight (lbs.)	13
Flywheel RPM	490
Maximum Log Length	16"
Maximum Log Diameter*	12"
Cycle Time (sec.)	1
Splitting Force	Out splits 5 ton Hydraulic
Wedge Height	5"
Wheel size	6"
Machine Height	24.5"
Machine Length	49"
Machine Width	11.875"
Weight	132

*The diameter listed is indicative of the maximum suggested size. A small log can be difficult to split when it contains knots or a particularly tough fiber. On the other hand, it may not be difficult to split logs with regular fibers even if its diameter exceeds the maximum indicated above.

Assembling the KINETIC LOG SPLITTER

Tools needed:

- 14mm Wrench (supplied with Splitter)

Note: The Frame Stand comes on the machine but needs to be rotated 180 degrees to be in the operating orientation.

1. Use a 14mm Wrench to remove the two Nuts and Lock Washers that hold the Frame Stand onto the Frame (**Figure 2**).
2. Remove the Frame Stand and rotate it 180 degrees. Reinstall it with the handle on the outside using the Nuts and Lock Washers removed in step 1 (**Figure 3**).

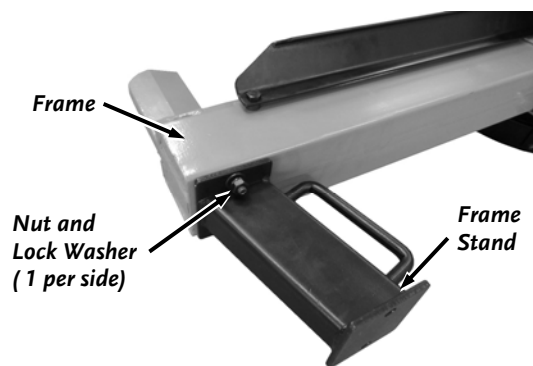

Figure 2

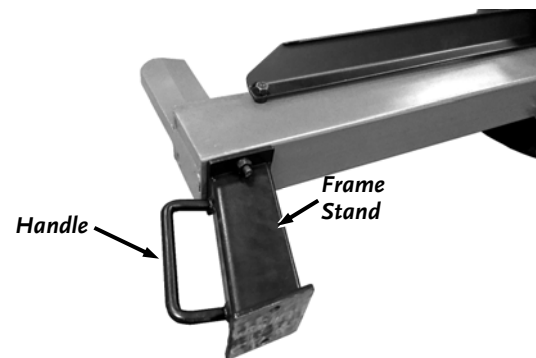

Figure 3

Chapter 3: Operating The KINETIC LOG SPLITTER

It may be helpful to better familiarize yourself with the features of your Log Splitter by reviewing **Figure 1** in Chapter 2 before beginning the steps outlined in this chapter.

WARNING

- Read and understand all instructions, safety precautions, and/or warnings listed in “Chapter 1 General Safety Rules” before operating this KINETIC LOG SPLITTER. If any doubt or question arises about the correct or safe method of performing anything found in this manual, please contact our Customer Service Representatives at our toll free number: 1-888-545-6576.
 - When operating the Log Splitter, make sure you are standing in the safe operating area (OPERATOR ZONE) as shown in **Figure 4**. You must stay in the safe operating area at all times when the ram is in motion (whether extending or retracting). Never place any part of your body into a position that causes an unsafe operating condition.
-

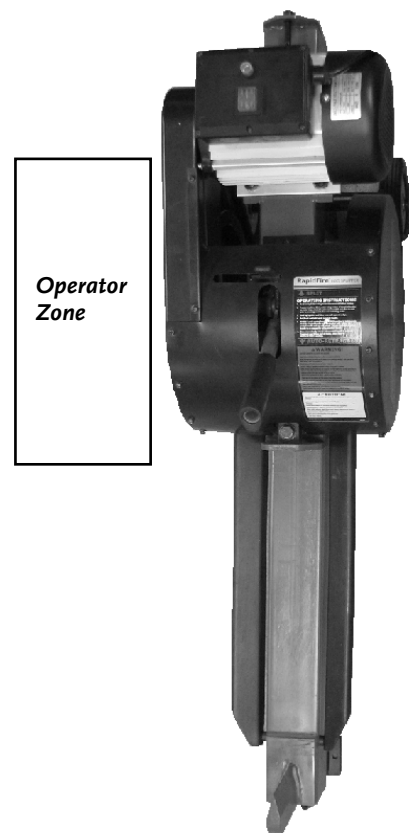

Figure 4

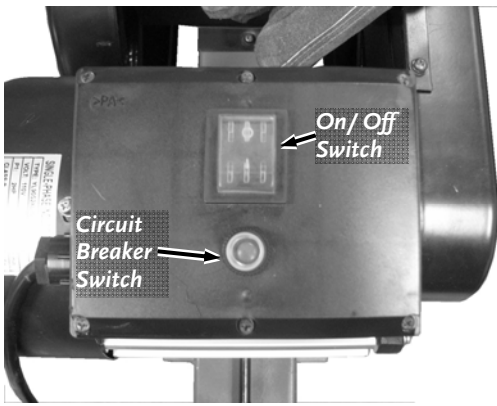

Figure 5

K 10 Operation

Refer to the “Safety with Electric - Powered Machines” section in Chapter 1 before using the Electric Motor for safety warnings and specific power and connection requirements.

Starting the Motor

1. Position your Log Splitter on a flat, dry surface and chock the Wheels or screw down the Frame Stand to prevent the Splitter from moving during use.
2. Make sure the Log Splitter is plugged into a properly grounded 20 Amp, GFCI protected outlet.
3. Push the red On/Off Switch to the On (I) position (**Figure 5**).

Stopping the Motor

1. Push the On/Off Switch to the Off (0) position to shut the Motor off (**Figure 5**).

Note: Unplug the Power Cord when not using the Splitter.

Resetting the Circuit Breaker

If the Motor will not run when the power Switch is turned on and power is connected to the machine, the Circuit Breaker Switch may need resetting. Read all instructions in the “Safety with Electric - Powered Machines” section in Chapter 1 to eliminate the typical causes for Circuit Breaker activation.

1. Push the Circuit Breaker Switch in to reset (**Figure 5**).



Figure 6

Splitting Logs

Note: All logs should be no longer than 16". Refer to the following photos for the correct and incorrect methods of splitting logs. Never split a log using an incorrect or unsafe method.



Figure 7

⚠ WARNING

- Do not place your hands on the ends of the log when loading the Log Splitter. This is a very UNSAFE method and could result in injury to your hands (**Figure 6**).
- Do not reach or step across the beam while the Log Splitter is running. This is a very UNSAFE method which could cause personal injury or even death.



Figure 8

⚠ CAUTION

- Never attempt to split wood across the grain (**Figure 7**). The Log Splitter was not designed for cross-grain splitting. Doing so could damage the Log Splitter and may cause personal injury.
- Make sure both ends of the log you are splitting are cut as square as possible (**Figure 8**). This will prevent the log from sliding out of position while under pressure.

NOTICE

THE KINETIC LOG SPLITTER OPERATES DIFFERENTLY THAN A HYDRAULIC SPLITTER. NOT OPERATING THE MACHINE PROPERLY WILL RESULT IN DAMAGE TO THE MACHINE. ALWAYS FOLLOW THESE NOTICES:

- Do not be timid. A rapid movement of the Engagement Handle is necessary for the Rack and Pinion to engage and disengage fully without damage.
- The Engagement Handle should never be stopped in any location between the fully forward or fully backward positions.
- Do not hold the Handle in the forward position when the Ram stops moving forward. Always pull the Engagement Handle RAPIDLY to the back (Auto-Retract) position as soon as the Log is split or when the Ram is at the end of the stroke or when the Ram stops moving forward due to a tough log.

1. Place the log on the Log Splitter. Grasp the log on the sides near the middle of the block (**Figure 9**). Center the log, side-to-side, on the rail of the Log Splitter, making sure that one end is against the Splitting Wedge.

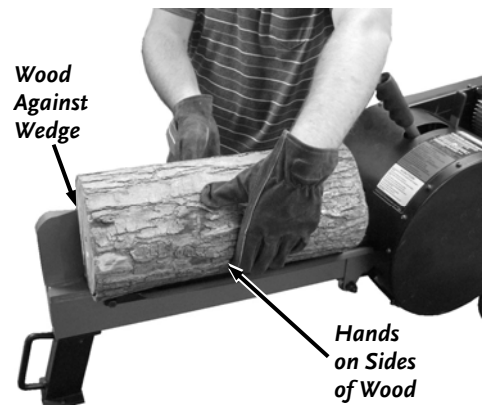

Figure 9

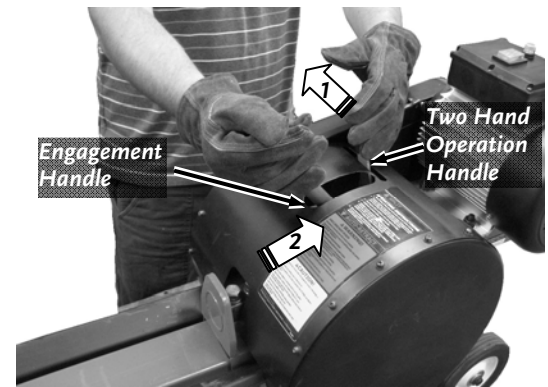

Figure 10

CAUTION

- The engagement Handle must be held fully in the Split Position against the hard stop when splitting. Failure to do so may result in kickback of the Handle.
2. With one hand, actuate and hold the Two Hand Operation Handle towards you, then **RAPIDLY** actuate the Engagement Handle fully towards the Motor until it contacts the hard stop and hold firmly until the Log is split (**Figure 10**).
 3. **IMMEDIATELY AFTER** the log is split, actuate and hold the Engagement Handle to the Auto-Retract position to allow the Ram to return. If the Ram stops before the end of the stroke while splitting a tough log, quickly actuate the Engagement Handle back to the Auto-Retract position.

Splitting Tough Logs

If the Ram stops before the end of the stroke while splitting a tough Log, quickly actuate the Engagement Handle back to the Auto-Retract position. Let the Ram return and allow the Flywheels to gain momentum for another full power split.

Chapter 4: Maintaining the KINETIC LOG SPLITTER

Regular maintenance is the way to ensure the best performance and long life of your machine. Please refer to this manual for proper maintenance procedures.

⚠ WARNING

Before performing any maintenance procedure or inspection, stop the motor, unplug the power cord and wait five minutes to allow all parts to cool.

Regular Maintenance Checklist

PROCEDURE	BEFORE EACH USE	EVERY 5 HOURS	EVERY 25 HOURS
Check General Equipment Condition	▲		
Perform Rail Maintenance	▲		
Check Belt	▲		
Check the condition of the electrical cord.	▲		
Grease Rack		▲	
Clean Motor Exterior and Cooling Fins			▲

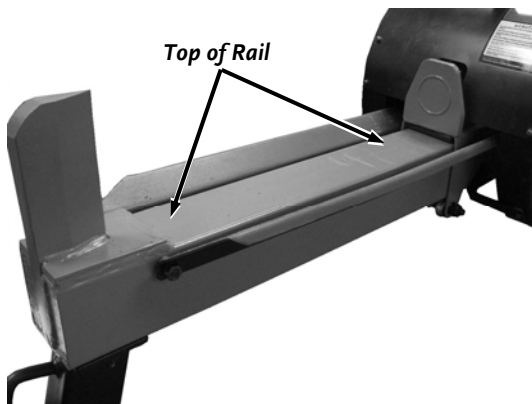

Figure 11

Lubrication

All Bearings of your Splitter are sealed units and should have sufficient lubricant to last the life of your machine with normal use. Perform machine lubrication per the following instructions.

Rail Maintenance

Between each use of the LOG SPLITTER, we recommend removing any debris caught on the Rail or Ram and applying a rust preventative (Fluid Film or equivalent) to any bare metal areas on the top of the Rail (**Figure 11**). This will assure the smoothest return action of the Ram.

Greasing the Rack

Note: It is important to grease the Rack every 5 hours for proper operation.

Tools and Supplies needed:

- General Purpose Grease
 - Clean Rags
 - Phillips Screwdriver
1. Use a Phillips Screwdriver to remove the 11 Guard Screws, Washers and Lock Washers that secure the Center Guard (**Figure 12**).
 2. Remove the Guard Screws, Washers and Lock Washers that secure the Flywheel and Belt Guard.

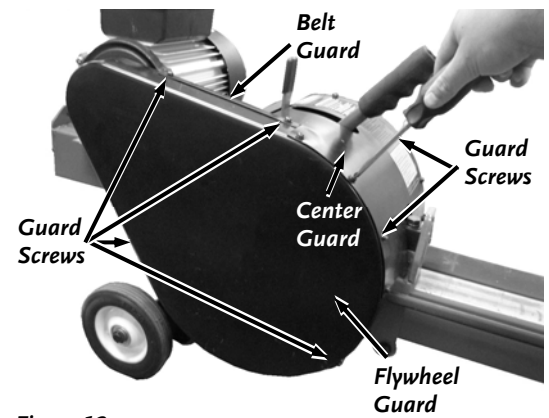

Figure 12

3. Disconnect the Return Spring from the Eye Bolt on the Frame (**Figure 13**).

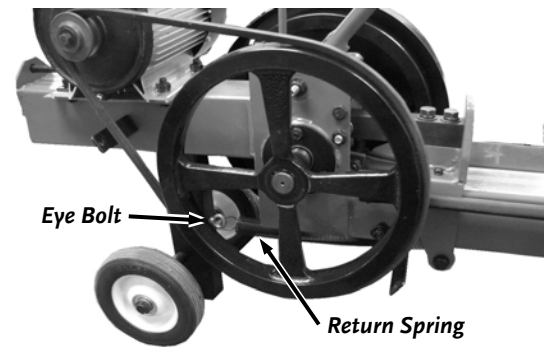

Figure 13

4. Pull the Rack out and grease the Rack Teeth, top side of the Rack and the Pinion (**Figure 14**).
5. Push the Rack back in and reinstall the Return Spring to the Eye Bolt when finished greasing.
6. Reinstall the Guards.

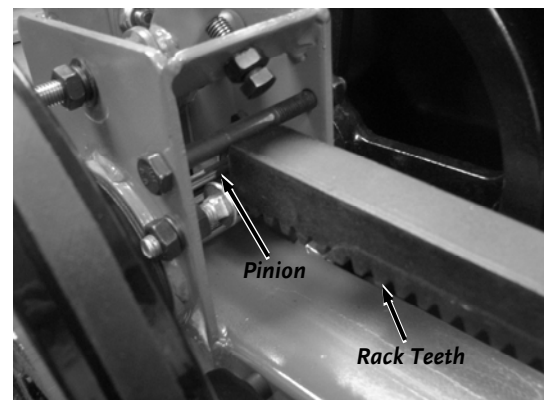

Figure 14

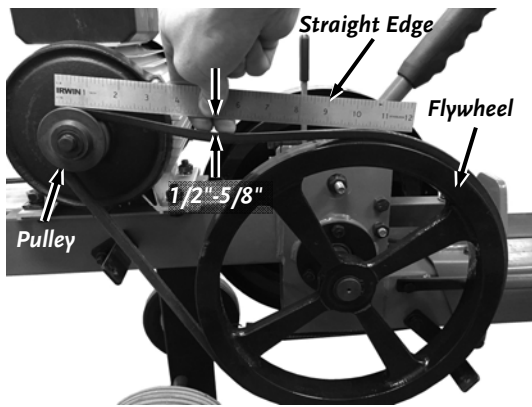

Figure 15

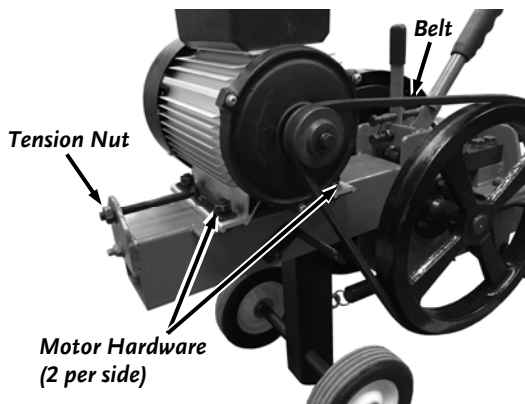

Figure 16

Adjusting and Replacing the Belt

Checking and Adjusting the Belt Tension

Note: The Belt performs best with a slight amount of slack as described below to allow for the belt to slip on the pulley when the Wedge encounters a tough log. Too much tension may stall the Motor.

Tools and Supplies needed:

- Phillips Screwdriver
- 14mm Wrench
- 17 mm Wrench

1. Remove the Center Guard, Flywheel Guard, and Belt Guard (see “Greasing the Rack” in this Chapter).
2. Place a Straight Edge across the top of the belt (**Figure 15**).
3. Push on the top of the Belt with about 10 pounds of pressure. The Belt should deflect approximately 1/2" to 5/8". If the distance is not between 1/2" and 5/8", adjust per the following directions.
4. Loosen the Motor Hardware using a 14mm Wrench on the bolt and a 17mm Wrench on the nut (**Figure 16**).
5. Use a 17mm Wrench to turn the Tension Nut in against the Frame to tighten (if Belt is too loose) or out to loosen (if Belt is too tight) for the correct Belt tension.
6. When the Belt is at the proper tension, tighten the Motor Hardware.
7. Reinstall the Guards.

Replacing the Belt

Tools and Supplies needed:

- Phillips Screwdriver
- 14mm Wrench
- 17 mm Wrench
- Belt: A1180

1. Remove the Center Guard, Flywheel Guard, and Belt Guard (see “Greasing the Rack” in this Chapter).
2. Loosen the Motor Hardware using a 14mm Wrench on the bolt and a 17mm Wrench on the nut (**Figure 16**).
3. Use a 17mm Wrench to loosen the Tension Nut until the Belt can be easily removed.
4. Install a new Belt onto the Pulley and Flywheel (**Figure 15**).
5. Tighten the Tension Nut against the Frame and follow the steps in the “Checking and Adjusting the Belt Tension” section to set the Belt tension.
6. Tighten the Motor Hardware.
7. Reinstall the Guards.

Adjusting the Steel Bushing Over Center

Tools needed:

- 14mm Wrench
- 17 mm Wrench
- Phillips Screwdriver

1. Remove the Center Guard, Flywheel Guard, and belt Guard (see “Greasing the Rack” in this Chapter).
2. Use a 17mm Wrench to remove the Nut and Lock Washer and a 14mm Wrench to remove the Stopping Bolt (**Figure 17**).

Note: Alternate loosening between the Nut and Stopping Bolt to remove them.

3. Move the Engagement Handle into the Split position (**Figure 18**).

Note: You May have to pull out on the Ram so that the Teeth on the Rack and Pinion line up.

4. Use a 17mm Wrench to loosen the Locking and Handle Retention Nuts on the Vertical Adjustment Bolt (**Figure 18**).

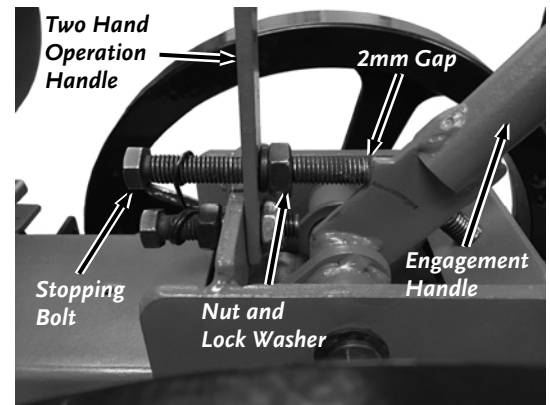

Figure 17

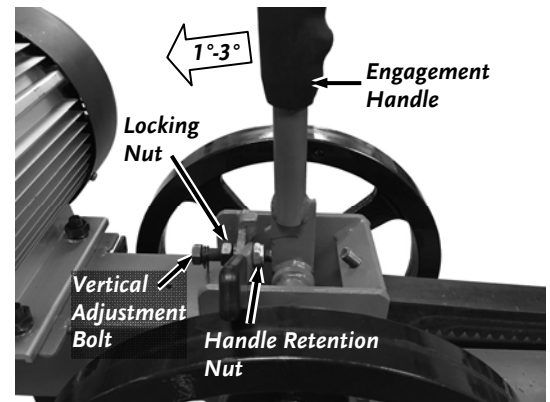

Figure 18

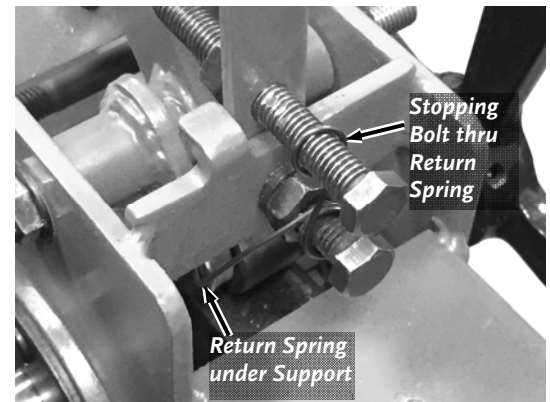

Figure 19

NOTICE

Do not adjust more than 1-1/4 revolutions when adjusting off center. Adjustments too far off center will not allow the Rack Teeth to engage fully and will cause damage to the Splitter.

5. Use a 14mm Wrench to adjust the Vertical Adjustment Bolt so the Engagement Handle is approximately 1 to 3 degrees off center towards the Vertical Adjustment Bolt.
6. Use a 17mm Wrench to tighten the Locking Nut and Handle Retention Nut. Make sure the Two Hand Operation Handle is able to move freely and return to the locked position. If the Handle cannot move freely, loosen the Handle Retention Nut 1/4 rotation at a time until it can move freely.

NOTICE

The Engagement Handle must move just past center as it contacts the Vertical Adjustment Bolt. If it is at the center position, or off center in the wrong direction, the force of splitting a log will be transferred through the Engagement Handle and could cause injury.

7. Push the Engagement Handle all the way to the Return Position then back into the Split Position to confirm the Steel Bushing is moving just past center.
8. Reinstall the Stopping Bolt, Nut and Lock Washer. Ensure that the Stopping Bolt goes through the Return Spring and that the Return Spring is anchored under the Frame Support (**Figure 19**). Leave a 2mm gap between the Stopping Bolt and the Engagement Handle (**Figure 17**).
9. Reinstall the Guards.

When using the Splitter for the first time after this adjustment, split smaller diameter logs with no knots to verify that the adjustments are correct before trying larger diameter tougher logs.

If you have any questions please contact us at 1-888-545-6576 for assistance.

Chapter 5: Troubleshooting

Most problems are easy to fix. Consult the Troubleshooting Table below for common problems and their solutions. If you continue to experience problems, contact us at 1-888-545-6576 for support.

WARNING

Before performing any maintenance procedure or inspection, stop the electric motor, wait five minutes to allow all parts to cool. Disconnect the power cord from the source of Electricity.

Troubleshooting Table

SYMPTOM	POSSIBLE CAUSE
<i>The Motor does not run</i>	<ul style="list-style-type: none"> ⇒ Splitter unplugged; plug Splitter in. ⇒ Splitter Cord may be damaged; call us at 1-888-545-6576 for assistance. ⇒ The Splitter motor circuit breaker has tripped; push the Reset Button. ⇒ If the above causes are not the problem, a circuit breaker of the electrical circuit you are plugged into might need to be reset; Reset Circuit Breaker. ⇒ If the Motor still does not run, call us at 1-888-545-6576 for assistance.
<i>Motor Reset continuously trips</i>	<ul style="list-style-type: none"> ⇒ Make sure the voltage at the outlet or extension cord connection to the Splitter is 110-120VAC. ⇒ If you are using an extension cord, make sure that the cord is no more than 25 feet long, is not smaller than 12 AWG wire or no more than 50 feet long, and is not smaller than 10 AWG wire. ⇒ The Belt is too tight. Check the Belt Tension and adjust to allow for slipping.
<i>Log fails to split.</i>	<ul style="list-style-type: none"> ⇒ Incorrect positioning of the log; re-position the log flat on the splitting beam with the end squarely against the Wedge. ⇒ Log exceeds permitted dimensions or the wood is too hard for the capacity of the machine. The maximum log length is 16" with a maximum diameter of 12" for the Splitter
<i>Rack returning very slow or not returning properly.</i>	<ul style="list-style-type: none"> ⇒ Check for wood chips or debris between ram and rail. Clean beam of built up/caked on debris. ⇒ Check rack lift bearing for alignment or damage. ⇒ Check interference between Ram and Tray. ⇒ Return spring is unhooked or damaged. Reconnect or replace as needed.
<i>Operator Lever snapping out of gear or not staying in gear.</i>	<ul style="list-style-type: none"> ⇒ Lever not all the way in the Split Position when rack comes under full load. Push lever quicker and more forcefully into the full Split Position. A hard stop should be felt at the end of the stroke when engaging the handle. ⇒ Vertical adjustment is not adjusted correctly. See the "Adjusting the Steel Bushing over Center" section in Chapter 4. ⇒ Ram has been overloaded at lower part of face. Check rack gear for straightness.
<i>With Motor running and the handle is pushed, the ram does not move or is slow to respond.</i>	<ul style="list-style-type: none"> ⇒ Make sure the voltage at the outlet or extension cord connection to the Splitter is 110-120VAC. ⇒ If you are using an extension cord, make sure that the cord is no more than 25 feet long, is not smaller than 12 AWG wire or no more than 50 feet long, and is not smaller than 10 AWG wire. ⇒ If the Wedge will still not move or is slow to respond, call us at 1-888-545-6576 for assistance

Troubleshooting Table (Continued)

WARNING

Before performing any maintenance procedure or inspection, stop the electric motor, wait five minutes to allow all parts to cool. Disconnect the power cord from the source of Electricity.

SYMPTOM	POSSIBLE CAUSE
<i>Rack slamming back too fast.</i>	⇒ Wedge end of machine too high. Must be almost level with ram end or just slightly higher. ⇒ Springs not operating properly. Fix or replace as needed.
<i>Machine does not seem to have full splitting power.</i>	⇒ The belt may be too loose. Adjust the belt as described in the “Checking and Adjusting the Belt Tension” section in Chapter 4.
<i>Operator Lever not engaging rack with pinion gear.</i>	⇒ Clean wood chips or other debris from under rack. ⇒ Clean accumulated dirt from frame where carriage assembly rests against rubber bumpers.
<i>Rack not disengaging from pinion when handle is released</i>	⇒ Belt must be loosened to allow for slipping while disengaging. Adjust belt as described in the “Checking and Adjusting the Belt Tension” section in Chapter 4.

Chapter 6: Parts Lists and Schematic Diagrams

Parts List – Flywheel and Guard Assembly

NOTE: Part numbers listed are available through Generac Power Systems.

Ref#	Part#	Description
72	353971	Leg Assembly
73	361031	Nut, Finish, M8, ZP
74	337431	Washer, Lock, M8
75	353931	Frame
76	364291	Bolt, HCS, M8 - 1.25 mm X 110 mm, CL 8.8, ZP
77	337431	Washer, Lock, M8
78	361031	Nut, Finish, M8, ZP
79	354051	Cradle, Log
80	354061	Spacer, Cradle, Log
81	302601	Bolt, HCS, M8-1.25 X 100 mm, CL 8.8, ZP
82	361031	Nut, Finish, M8, ZP
82-1	337431	Washer, Lock, M8
83	337031	Bolt, HCS, M8-1.25 X 25 mm, CL 8.8, ZP
83-1	337431	Washer, Lock, M8
83-2	361031	Nut, Finish, M8, ZP
84	354081	Key, Flywheel, 8 mm X 7 mm X 20 mm
85	353991	Pinion
86	354041	Cover, Flywheel, Left
87	337031	Bolt, HCS, M8-1.25 X 25 mm, CL 8.8, ZP
87-1	337431	Washer, Lock, M8
87-2	361031	Nut, Finish, M8, ZP
88	353911	Flange, Bearing
89	353921	Flywheel
89-1	363181	Screw, Set, M8 X 1.0 X 8mm
90	361011	Snap Ring, External, 24 mm X 1.2 mm
91	360931	Bearing, Roller, 30mm X 55mm X 13mm
92	363251	Screw, M5-.8 mm X 10 mm
93	364321	Washer, Flat, M5
93-1	364331	Washer, Split-Lock, M5
94	364271	Belt, A1180
95	354011	Cover, Center
96	364371	Cover, Belt, Right, Small
97	354001	Cover, Flywheel, Right
98	354031	Bracket, Cover

Schematic – Flywheel and Guard Assembly

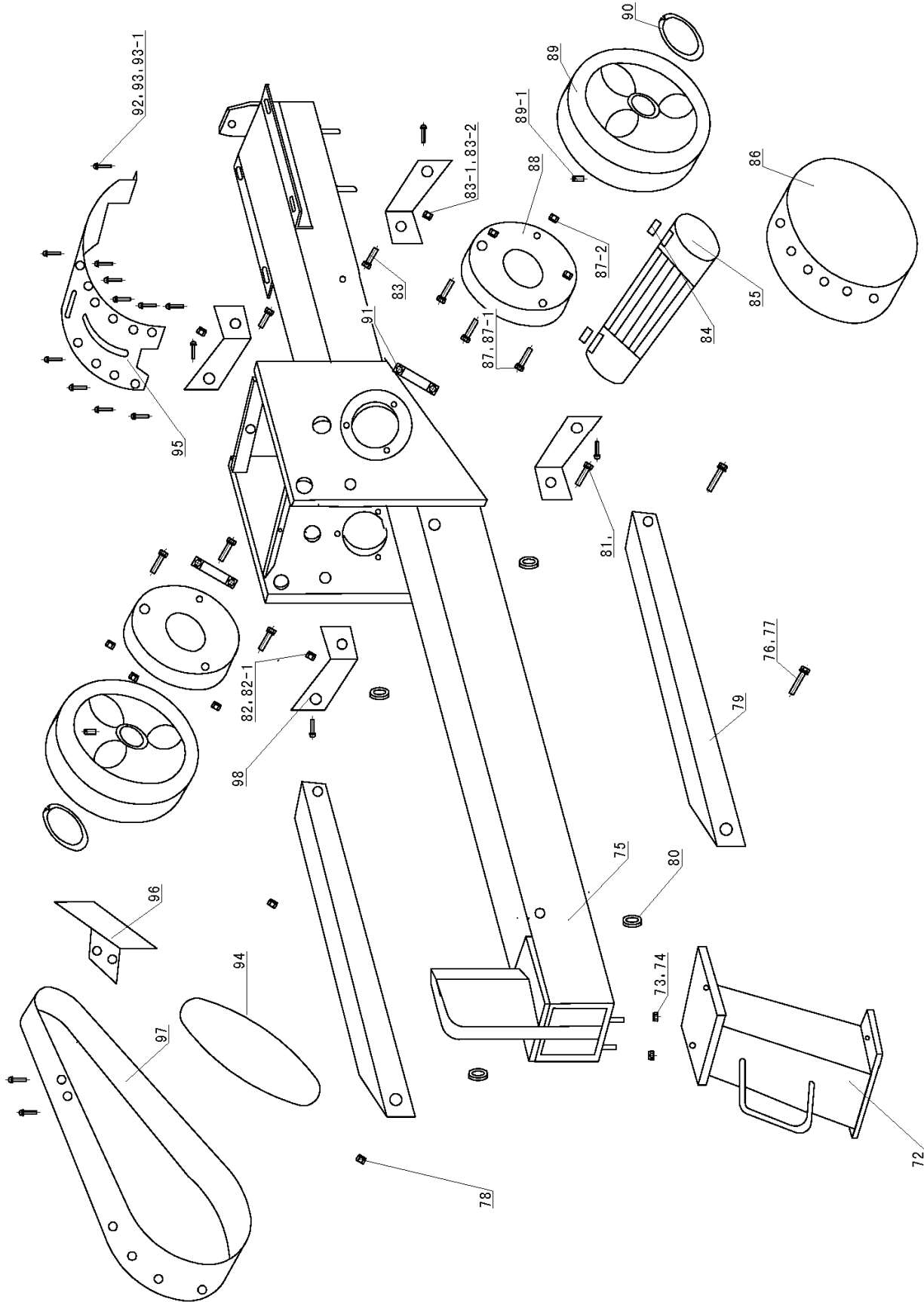

Parts List – Frame and Motor Assembly

NOTE: Part numbers listed are available through Generac Power Systems.

Ref#	Part#	Description	Ref#	Part#	Description
4	364221	Bolt, HCS, M10 - 1.50 mm X 30 mm, CL 8.8, ZP	42	302521	Washer, M12
5	302501	Washer, M10	43	354111	Ram Assembly
6	364231	Washer, Split-Lock, M10	44	364341	Nut, Finish, M5
7	303591	Nut, Hex, M10-1.5	45	364331	Washer, Split-Lock, M5
8	360911	Spring, Return, 2 Hand Op	45-1	364321	Washer, Flat, M5
9	364241	Bolt, HCS, M10 X 75mm, CL 8.8, ZP	46	354201	Slider
10	360871	Bolt, HCS, M10 X 50mm, CL 8.8, ZP	47	364311	Bolt, SH Counter Sink, M5-.8 mm X 20 mm, ZP
11	303591	Nut, Hex, M10-1.5	48	303591	Nut, Hex, M10-1.5
12	364231	Washer, Split-Lock, M10	49	302501	Washer, M10
13	302491	Nut, Locking, M10	49-1	364231	Washer, Split-Lock, M10
14	359811	Handle, Two-Hand Op	50	360861	Bearing, Roller, 10 mm X 25 mm X 11 mm
14-1	360891	Cover, Handle Grip, 2 Hand Op	51	302501	Washer, M10
15	360901	Cover, Handle Grip, Actuation	52	360961	Spacer, Ram
16	363191	Handle, Actuation	53	360991	Bolt, HCS, M10 - 1.50 mm X 110 mm, CL 12.9, ZP
19	303591	Nut, Hex, M10-1.5	54	363271	Pin, Roll, 3 mm X 20 mm
19-1	302501	Washer, M10	55	303611	Washer, Flat, M16
19-2	364231	Washer, Split-Lock, M10	56	354091	Wheel
20	360991	Bolt, HCS, M10 - 1.50 mm X 110 mm, CL 12.9, ZP	57	372011	Spring, Return
21	364251	Bolt, HCS, M12 - 1.75 mm X 50 mm, CL 8.8 ZP	58	353941	Mount Assembly, Axle
22	364351	Bushing, Handle	59	361051	Tension, Belt
23	302521	Washer, M12	60	303591	Nut, Hex, M10-1.5
24	303591	Nut, Hex, M10-1.5	61	337431	Washer, Lock, M8
25	363221	Nut, Finish, M12, ZP	62	361041	Bumper, Ram Stop
26	364221	Bolt, HCS, M10 - 1.50 mm X 30 mm, CL 8.8, ZP	63	361031	Nut, Finish, M8, ZP
27	303591	Nut, Hex, M10-1.5	64	292511	Washer, Flat, M8
28	364231	Washer, Split-Lock, M10	65	337431	Washer, Lock, M8
29	354121	Roller Assembly, Spring	67	302501	Washer, M10
31	361021	Bolt, Carriage, M10 - 1.50 mm X 50 mm, CL 8.8, ZP	68	303591	Nut, Hex, M10-1.5
32	303591	Nut, Hex, M10-1.5	51	302501	Washer, M10
33	364231	Washer, Split-Lock, M10	69	364231	Washer, Split-Lock, M10
34	363241	Bearing, Lift, 10 mm X 22 mm X 6 mm	99	361071	Pulley, Dual Belt, 55mm X 19mm
34-1	364211	Spacer, Bearing, Lift	100	360951	Motor, 1060w
35	364301	Bolt, Hcs, M10 - 1.50 mm X 35 mm, CL 8.8, ZP	101	361081	Key, 6mm X 6mm X 25mm
36	303591	Nut, Hex, M10-1.5	102	372021	Bolt, HCS, M8-1.25 mm X 15 mm, CL 8.8, ZP
36-1	364231	Washer, Split-Lock, M10	102-1	337431	Washer, Lock, M8
37	361061	Spring, Ram, Lifter	102-2	292511	Washer, Flat, M8
38	337031	Bolt, HCS, M8-1.25 X 25 mm, CL 8.8, ZP	105	364231	Washer, Split-Lock, M10
38-1	337431	Washer, Lock, M8	Not Illustrated		
38-2	361031	Nut, Finish, M8, ZP	363201	Label, Warning, Operator	
39	354151	Rack	363211	Label Branding	
40	364261	Bolt, HCS, M12 - 1.25 mm X 60 mm	250441	Label, Warning, Pinch Point, 3.5x1	
41	360981	Washer, Split-Lock, M12	351871	Label, 5"	

Schematic – Frame and Motor Assembly

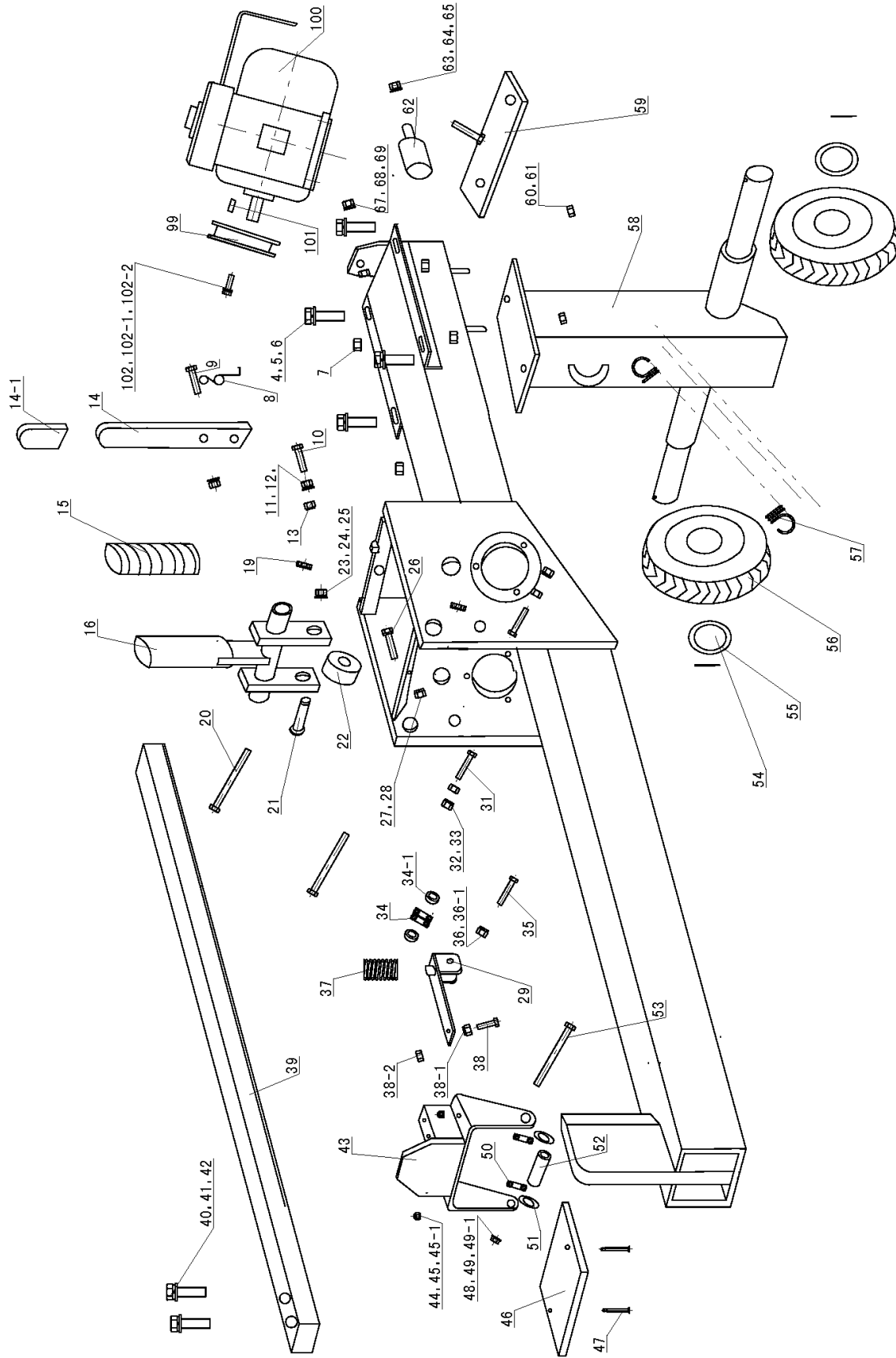

Notes:



GENERAC[®] KINETIC LOG SPLITTER

2-Year Limited Warranty

Terms and Conditions

The **GENERAC[®]** KINETIC LOG SPLITTER is warranted for two (2) years against defects in materials or workmanship when put to ordinary and normal consumer use; ninety (90) days for any other use.

For the purposes of all the above warranties, "ordinary and normal consumer use" refers to non-commercial residential use and does not include misuse, accidents or damage due to inadequate maintenance.

Generac Power Systems certifies that the **GENERAC[®]** KINETIC LOG SPLITTER is fit for ordinary purposes for which a product of this type is used. Generac Power Systems however, limits the implied warranties of merchantability and fitness in duration to a period of two (2) years in consumer use, ninety (90) days for any other use.

The 2-Year Limited Warranty on the **GENERAC[®]** KINETIC LOG SPLITTER starts on the date the machine ships from our factory. The 2-Year Limited Warranty is applicable only to the original owner.

The warranty holder is responsible for the performance of the required maintenance as defined by the manufacturer's owner's manuals. The warranty holder is responsible for replacement of normally wearing parts such as the Drive Belt. Accessories to the machine are not covered by this warranty.

During the warranty period, the warranty holder is responsible for the machine transportation charges, if required. During the warranty period, warranty parts will be shipped by standard method at no charge to the warranty holder. Expedited shipping of warranty parts is the responsibility of the warranty holder.

SOME STATES DO NOT ALLOW LIMITATIONS ON THE LENGTH OF IMPLIED WARRANTIES, SO THE ABOVE LIMITATIONS MAY NOT APPLY TO YOU.

Generac Power Systems shall not be liable under any circumstances for any **incidental or consequential damages or expenses** of any kind, including, but not limited to, cost of equipment rentals, loss of profit, or cost of hiring services to perform tasks normally performed by the **GENERAC[®]** KINETIC LOG SPLITTER.

SOME STATES DO NOT ALLOW THE EXCLUSION OR LIMITATION OF INCIDENTAL OR CONSEQUENTIAL DAMAGES, SO THE ABOVE LIMITATIONS MAY NOT APPLY TO YOU.

THIS WARRANTY GIVES YOU SPECIFIC LEGAL RIGHTS, AND YOU ALSO HAVE OTHER RIGHTS, WHICH VARY FROM STATE TO STATE.

Daily Checklist for the KINETIC LOG SPLITTER

To help maintain your KINETIC LOG SPLITTER for optimum performance, we recommend you follow this checklist each time you use your Log Splitter.

! WARNING

Before performing any maintenance procedure or inspection, stop the motor, wait five minutes to allow all parts to cool. Disconnect the power cord from the source of Electricity.

- Check that motor cooling fins are clean of debris.
- Check the general condition of the Log Splitter, e.g.; Nuts, Bolts, Welds, etc.
- Check the Frame for wear and damage.
- Check the Wedge for nicks and wear. Sharpen if needed.
- Apply a rust preventative (Fluid Film or equivalent) to any bare metal areas on the top of the Rail. This will assure the longest possible service life of the Wedge.

End of Season and Storage

! WARNING

Before performing any maintenance procedure or inspection, stop the motor, wait five minutes to allow all parts to cool. Disconnect the power cord from the source of Electricity.

- Check the Wedge for nicks and wear. Sharpen if needed.
- Apply Grease to the Rack and Pinion Teeth.
- Apply a rust preventative (Fluid Film or equivalent) to any bare metal areas on the top of the Rail.
- Clean the exterior of the unit to remove all dirt, grease, and any other foreign material. Clean dirt and debris from the motor cooling Fins. To prevent rust, touch up painted surfaces that have been scratched or chipped.
- Be sure all Nuts, Bolts, and Screws are securely fastened.
- If possible, store the Log Splitter in a dry, protected place. If it is necessary to store the Log Splitter outside, cover it with a protective material (especially the Motor).



75 MEIGS ROAD, P.O. BOX 25, VERGENNES, VERMONT 05491