

# DR<sup>®</sup> RAPIDFIRE™ LOG SPLITTER



## Tray Kit# 32130

These instructions are for installation of the Tray Kit. Please keep these instructions with your Splitter Safety and Operating Instructions manual for future reference.

### Parts Supplied in Tray Kit (Figure 1):

Item #	Part #	Description	Qty
1	313631	Table, Log (not shown)	1
2	321041	Bolt, Carriage, 3/8-16 X 1", GR5, ZP	4
3	333331	Nut, Nylon Lock, Flanged, 3/8-16	4
4	150431	Bolt, HHCS, 3/8-16 X 1-1/4", GR5	4
5	112411	Washer, Flat, 5/16", USS, ZP	4
6	180811	Washer, Lock, 3/8"	4

Compare the contents of the Tray Kit with the "Parts Supplied" list above. If you have any questions please contact us at [www.DRpower.com](http://www.DRpower.com) or call 1-800-DR-OWNER (376-9637) for assistance.

### **⚠ WARNING**

Before performing this kit installation, stop the engine, wait five minutes to allow all parts to cool. Disconnect the spark plug wire, keeping it away from the spark plug. Disconnect the Battery Terminals (Electric start only).

### Tools needed:

- Large Jack Stand or equivalent
- 9/16" Wrench

### Removing the Cradles

1. Support the end of the Beam with a Jack Stand or equivalent to position the Beam parallel with the ground.
2. Remove the three Carriage Bolts and Locknuts for each Cradle using a 9/16" Wrench and remove the Cradles (Figure 2).
3. Remove the four Bolts and Locknuts the front Cradle Bracket using two 9/16" Wrenches Install to the end of the Beam with (Figure 3).
4. Remove the four Bolts and Lock Washers securing the Tow Bar using two 9/16" Wrenches and remove the Tow Bar (Figure 4).

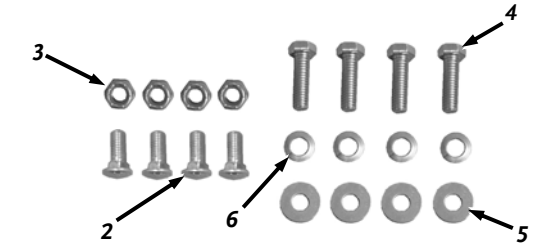

Figure 1

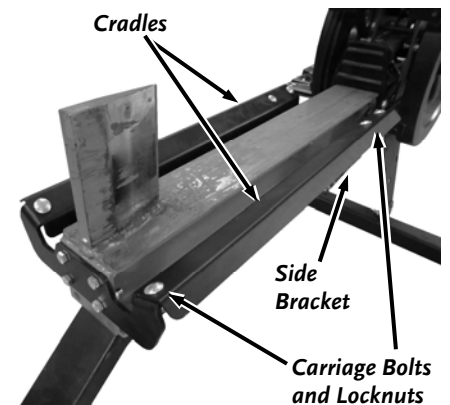

Figure 2

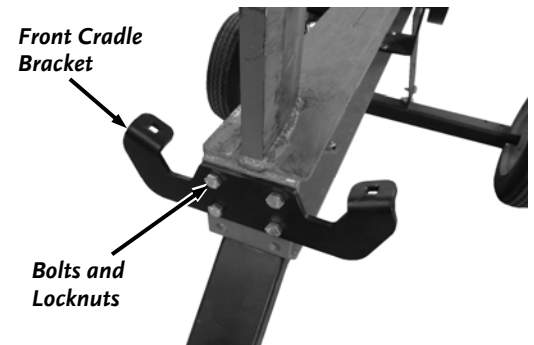

Figure 3

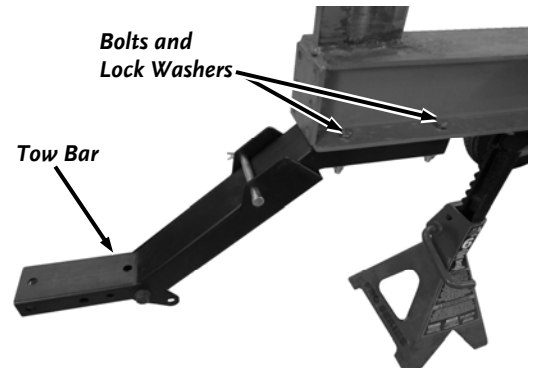

Figure 4

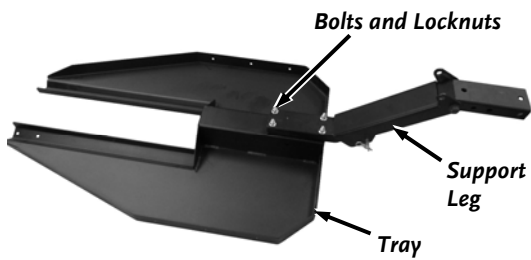

Figure 5

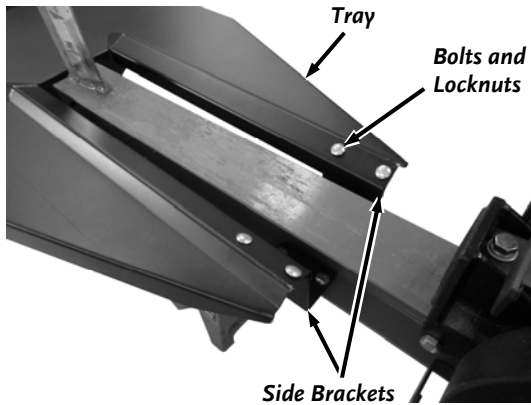

Figure 6

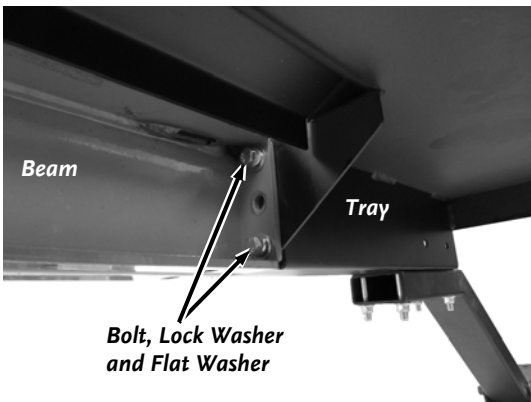

Figure 7

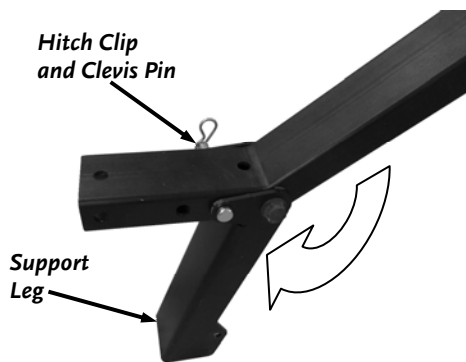

Figure 8

5. Install the Tow Bar to the end Tray with four Bolts and Lock Washers (from product package) using two 9/16" Wrenches (**Figure 5**).
6. For easier alignment in the following step, slightly loosen the Side Bracket Hardware using a 9/16" Wrench (**Figure 6**).
7. Position the Tray onto the Side Brackets and install the four Carriage Bolts and Locknuts (from the tray kit) by hand.
8. Install the four Bolts, Lock Washers and Flat Washers (from the tray kit) to secure the Tray to the end of the Beam using a 9/16" Wrench (**Figure 7**).
9. Tighten all remaining Tray hardware using a 9/16" Wrench.
10. The Leg may already be in the down position but if it is not then pull the Hitch Clip and Clevis Pin from the Leg and fold it to the down position. Align the holes and secure the Leg with the Clevis Pin and Hitch Clip (**Figure 8**).
11. Remove the Jack Stand and lower the Splitter onto the Support Leg.

If you have any questions please contact us at [www.DRpower.com](http://www.DRpower.com) or call 1-800-DR-OWNER (376-9637) for assistance.