

**DR<sup>®</sup> TRIMMER/MOWER™**



---

## SAFETY & OPERATING INSTRUCTIONS

Models: Premier, Pro, Pro-XL, Pro-XL Self-Propelled



Serial No. \_\_\_\_\_

Order No. \_\_\_\_\_

DR Power Equipment  
Toll-free phone: 1-800-DR-OWNER (376-9637)  
Fax: 1-802-877-1213  
Website: [www.DRpower.com](http://www.DRpower.com)

---

**⚠ WARNING**

Read and understand this manual and all instructions before operating the DR TRIMMER/MOWER.

---

# Table of Contents

Chapter 1: General Safety Rules..... 3  
Chapter 2: Setting Up The DR TRIMMER/MOWER ..... 6  
Chapter 3: Operating the DR TRIMMER/MOWER ..... 11  
Chapter 4: Maintaining The DR TRIMMER/MOWER..... 17  
Chapter 5: Troubleshooting ..... 28  
Chapter 6: Parts Lists and Schematic Diagrams..... 32

## Conventions used in this manual

### **WARNING**

This indicates a hazardous situation, which, if not avoided, could result in death or serious injury.

### **CAUTION**

This indicates a hazardous situation, which, if not avoided, could result in minor or moderate injury.

### **NOTICE**

This information is important in the proper use of your machine. Failure to follow this instruction could result in damage to your machine or property.

OUTDOOR POWER	
MODEL/MODELO	XXXXXXX
SERIAL NO	SERIAL #
N° DE SERIE	XXXXXXX
NU DE SERIE	XXXXXXX
POWER (KW)	XXXXXXX
WEIGHT (KG)	XXXXXXX
ITEM #	XXXXXXX
MANUFACTURED DATE	XXXXXXX
	
COUNTRY HOME PRODUCTS, INC. 75 MEIGS RD VERGENNES, VT 05491	
COUNTRY OF ORIGIN	XXXXXX
XXXXXX	

## Serial Number and Order Number

A Serial Number is used to identify your machine and is located on the Serial Number Label on your machine. An Order Number is used to check and maintain your order history and is located on the upper left portion of your packing slip. For your convenience and ready reference, enter the Serial Number and Order Number in the space provided on the front cover of this manual.

## Additional Information and Potential Changes

DR Power Equipment reserves the right to discontinue, change, and improve its products at any time without notice or obligation to the purchaser. The descriptions and specifications contained in this manual were in effect at printing. Equipment described within this manual may be optional. Some illustrations may not be applicable to your machine.

## California Proposition 65

 **WARNING**  
**CANCER AND REPRODUCTIVE HARM - [www.P65Warnings.ca.gov](http://www.P65Warnings.ca.gov).**

## Chapter 1: General Safety Rules

### **WARNING**

Read this safety & operating Instructions manual before you use the DR TRIMMER/MOWER. Become familiar with the operation and service recommendations to ensure the best performance from your machine. If you have any questions or need assistance, please contact us at [www.DRpower.com](http://www.DRpower.com) or call toll-free 1-800-DR-OWNER (376-9637) and one of our Technical Support Representatives will be happy to help you.

### Labels

Your DR TRIMMER/MOWER carries prominent labels as reminders for its proper and safe use. Shown below are copies of the Safety and Information labels that appear on the equipment. Take a moment to study them and make a note of their location on your DR TRIMMER/MOWER as you set up and before you operate the unit. Replace damaged or missing safety and information labels immediately.



#13649



#14823

**WARNING: Check Oil  
Before Starting Engine**

#13758

**VARIABLE SPEED DRIVE**

#32343

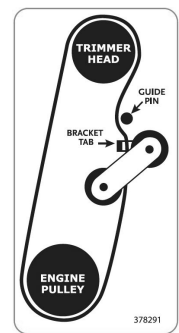

#37829

### Protecting Yourself and Those Around You

### **WARNING**

This is a high-powered machine, with moving parts operating with high energy at high speeds. You must operate the machine safely. Unsafe operation can create a number of hazards for you, as well as anyone else in the nearby area. Always take the following precautions when using this machine:

- Keep in mind that the operator or user is responsible for accidents or hazards occurring to other people, their property, and themselves.
- Always wear protective goggles or safety glasses with side shields while mowing to protect your eyes from possible thrown debris.
- Avoid wearing loose clothing or jewelry, which can catch on the mower's moving parts.
- We recommend wearing gloves while mowing. Be sure your gloves fit properly and do not have loose cuffs or drawstrings.
- Wear shoes with non-slip treads when using your DR TRIMMER/MOWER. If you have safety shoes, we recommend wearing them. Do not use the machine while barefoot or wearing sandals with exposed toes or heels.
- Wear long pants while operating the DR TRIMMER/MOWER.
- Use ear protectors or ear plugs rated for at least 20 dba to protect your hearing.
- Keep bystanders at least 50 feet away from your work area at all times. The tips of the cutting cords on the DR TRIMMER/MOWER can throw sticks, small stones, gravel, and bits of debris over long distances at great velocity. Do not travel over loose materials such as gravel or mulch with the trimmer head spinning. Doing so could cause personal injury or property damage from thrown objects. Release the bail bar to stop the spinning cords and shut off the engine when another person or pet approaches.
- Never tamper with safety devices. Check their proper operation regularly.
- Never operate the machine when under the influence of alcohol, drugs, or medication.
- In an emergency, to quickly stop the cutting cords, remove your hand from the bail bar.

## Operating the Mower Safely

### **WARNING**

This is a high-powered machine, with moving parts operating with high energy at high speeds. You must operate the machine safely. Unsafe operation can create a number of hazards for you, as well as anyone else in the nearby area. Always take the following precautions when using this machine:

- Never allow people who are unfamiliar with these instructions to use the DR TRIMMER/MOWER. Allow only responsible individuals who are familiar with these rules of safe operation to use your machine.
- Never place your hands, feet, or any part of your body on or under the mower deck in the path of the spinning cords, belt, pulleys, or near the discharge opening while the engine is running. Keep area of discharge clear of people, animals, buildings, glass, or anything else that will obstruct clear discharge, cause injury, or damage.
- Your DR Trimmer/Mower is a powerful tool, not a plaything. Exercise extreme caution at all times. The design of your machine is for trimming and mowing grass, weeds, and other growth as specified in this manual. Do not use it for any other purpose.
- Whenever you leave the operating position to make adjustments, change cords or if you have to remove grass or debris from the underside of the deck, always shut off the engine and wait five (5) minutes to allow parts to cool. Remove the key, if so equipped, and disconnect the spark plug wire and keep the wire away from the spark plug to prevent accidental starting.
- When operating over uneven terrain and slopes, use extreme caution to ensure solid and firm footing. Keep a firm hold on the handlebar and walk, never run.
- Stop the cutting cords when crossing gravel drives, walks, or roads.
- Never operate your unit on a slippery, wet, or muddy surface. Exercise caution to avoid slipping or falling.
- Always operate the mower from behind the handlebar. Never pass or stand on the discharge side of the machine when the engine is running or cutting cords are spinning.
- Never, under any conditions, remove, bend, cut, fit, weld, or otherwise alter standard parts on the DR TRIMMER/MOWER. This includes all shields and guards. Modifications to your machine could cause personal injuries and property damage and will void your warranty.
- If the cutting cords strike a foreign object or if your machine should start making an unusual noise or vibration, stop the engine and wait five (5) minutes for all moving parts to come to a complete stop and cool. Vibration is generally a warning of trouble. Disconnect the spark plug wire and inspect for damage. Clean and repair and/or replace damaged parts.
- While using the DR TRIMMER/MOWER, do not hurry or take things for granted. When in doubt about the equipment or your surroundings, stop the machine and take the time to look things over. Make sure that you have 100% control of the mower at all times.
- Watch for traffic when mowing near roadways.
- Use the machine only in daylight.
- Be cautious when using your DR TRIMMER/MOWER around fencing, wires, ropes, and hoses. It is possible that these and other debris can become wound around the line plates of the machine, potentially damaging the bearings or injuring you.
- Do not operate the DR TRIMMER/MOWER on slopes greater than 20 degrees.
- Keep all nuts and bolts tight and keep the equipment in good operating condition.

## Safety for Children and Pets

### **WARNING**

Tragic accidents can occur if the operator is not alert to the presence of children and pets. Children are often attracted to the machine and the mowing activity. *Never* assume that children will remain where you last saw them. Always follow these precautions:

- Keep children and pets out of the working area and under the watchful care of a responsible adult.
- Be alert and turn the machine off if children or pets enter the work area.
- Never allow children to operate the DR TRIMMER/MOWER.
- Use extra care when approaching blind corners, shrubs, trees, or other objects that may obscure your vision.

## Safety with Gasoline - Powered Machines

---

### **WARNING**

Gasoline is a highly flammable liquid. Gasoline also gives off flammable vapor that can be easily ignited and cause a fire or explosion. Never overlook the hazards of gasoline. Always follow these precautions:

- Never run the engine in an enclosed area or without proper ventilation as the exhaust from the engine contains carbon monoxide, which is an odorless, tasteless, and deadly poisonous gas.
  - Store all fuel and oil in containers specifically designed and approved for this purpose and keep away from heat and open flame, and out of the reach of children.
  - Replace rubber fuel lines and grommets when worn or damaged and after 5 years of use.
  - Fill the gasoline tank outdoors with the engine off and allow the engine to cool completely. Don't handle gasoline if you or anyone nearby is smoking, or if you're near anything that could cause it to ignite or explode. Reinstall the fuel tank Cap and fuel container cap securely.
  - If you spill gasoline, do not attempt to start the engine. Move the machine away from the area of the spill and avoid creating any source of ignition until the gas vapors have dissipated. Wipe up any spilled fuel to prevent a fire hazard and properly dispose of the waste.
  - Allow the engine to cool completely before storing in any enclosure. Never store a machine that has gas in the tank, or a fuel container, near an open flame or spark such as a water heater, space heater, clothes dryer or furnace.
  - Never make adjustments or repairs with the engine running. Shut down the engine, wait 5 minutes, disconnect the spark plug wire, keeping it away from the spark plug to prevent accidental starting before making adjustments or repairs.
  - Never tamper with the engine's governor setting. The governor controls the maximum safe operation speed and protects the engine. Over-speeding the engine is dangerous and will cause damage to the engine and to the other moving parts of the machine. If required, see your authorized dealer for engine governor adjustments.
  - Keep combustible substances away from the engine when it is hot.
  - Never cover the machine while the muffler is still hot.
  - Do not operate the engine with the air cleaner or cover over the carburetor air-intake removed, except for adjustment. Removal of such parts could create a fire hazard. Do not use flammable solutions to clean the air filter.
  - The muffler and engine become very hot with use and can cause a severe burn; do not touch. Allow the engine to cool before refueling, doing maintenance, or making adjustments.
  - Do not mow in the rain. Water on the spark plug may cause the engine to stall.
  - Keep combustible substances away from the engine when it is hot.
  - Never cover the machine while the muffler is still hot.
- 

### **A Note to All Users**

Under California law, and the laws of some other states, you are not permitted to operate an internal combustion engine using hydrocarbon fuels without an engine spark arrester. This also applies to operation on US Forest Lands. All DR<sup>®</sup> TRIMMER/MOWERS shipped to California, New Mexico and Washington State are provided with spark arresters. Failure of the owner or operator to maintain this equipment in compliance with state regulations is a misdemeanor under California law and may be in violation of other state and/or federal regulations. Contact your State Park Association or the appropriate state organization for specific information in your area.

No list of warnings and cautions can be all-inclusive. If situations occur that are not covered by this manual, the operator must apply common sense and operate this DR TRIMMER/MOWER in a safe manner. Contact us at [www.DRpower.com](http://www.DRpower.com) or call 1-800-DR-OWNER (376-9637) for assistance.

## Chapter 2: Setting Up The DR TRIMMER/MOWER

It may be helpful to familiarize yourself with the controls and features of your DR TRIMMER/MOWER as shown in **Figure 1** before beginning these procedures. If you have any questions at all, please feel free to contact us at [www.DRpower.com](http://www.DRpower.com).

### **DR TRIMMER/MOWER Controls and Features**

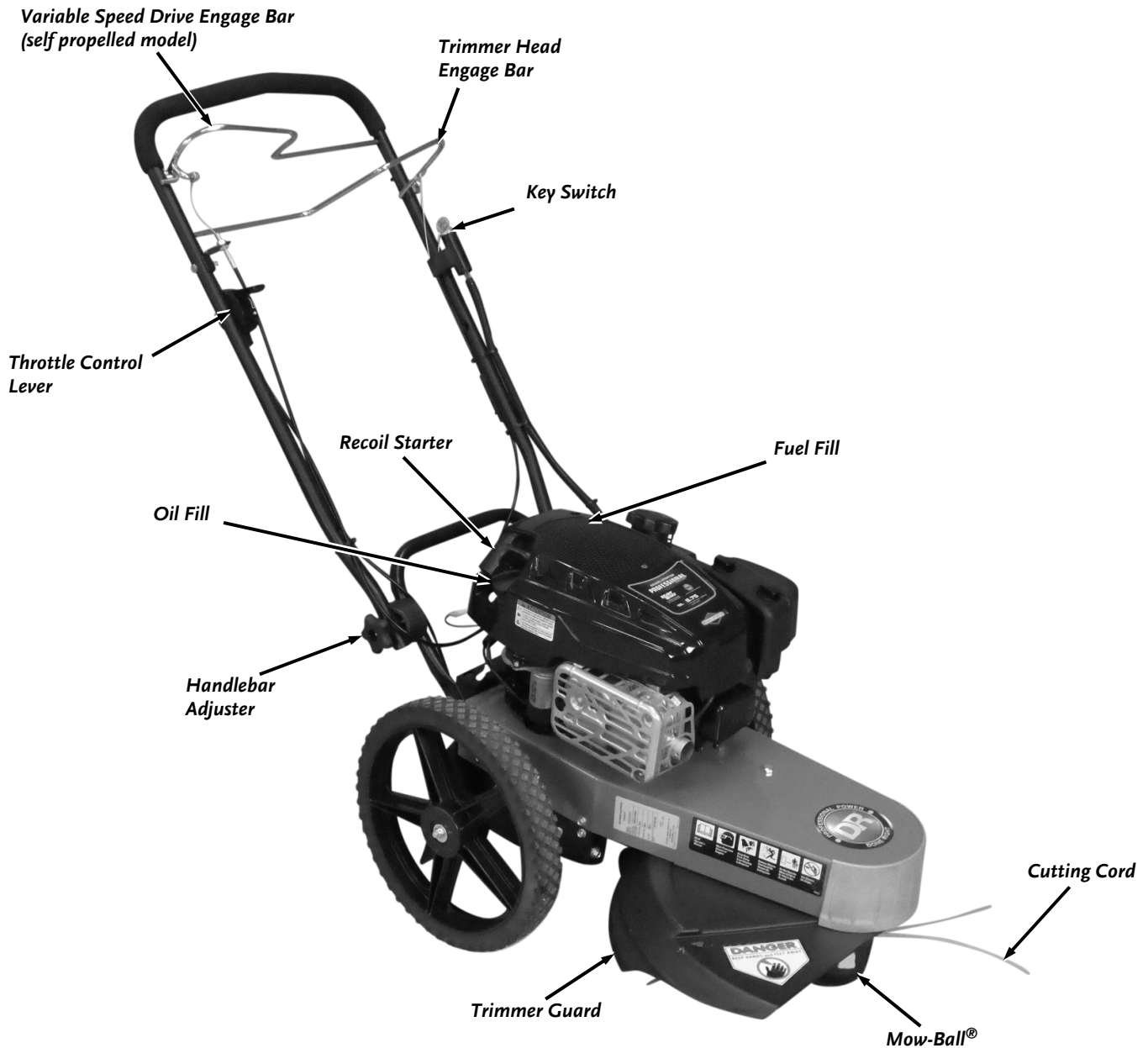

Figure 1

## Specifications

	Premier	Pro	Pro-XL	Pro-XL SP
<b>Engine</b>	Briggs and Stratton 6.75 EXi Manual or Electric Start. See Engine Owners Manual for details	Briggs and Stratton 7.25 EXi Manual or Electric Start. See Engine Owners Manual for details	Briggs and Stratton 8.75 Manual or Electric Start. See Engine Owners Manual for details	Briggs and Stratton 8.75 Electric Start. See Engine Owners Manual for details
<b>Engine Speed</b>	3500 rpm	3500 rpm	3500 rpm	3500 rpm
<b>Cutting Width</b>	22"	22"	22"	22"
<b>Cutting Height</b>	5 Heights, 1.5" to 3.5"	5 Heights, 1.5" to 3.5"	5 Heights, 1.5" to 3.5"	5 Heights, 1.5" to 3.5"
<b>Cutting Speed</b>	3800 RPM	3800 RPM	3800 RPM	3800 RPM
<b>Cord Size</b>	Green .155" Round, Blue .175" Spiral, 25" Long	Green .155" Round, Blue .175" Spiral, 25" Long	Green .155" Round, Blue .175" Spiral, 25" Long	Green .155" Round, Blue .175" Spiral, 25" Long
<b>Wheels</b>	14" x 1.75" Wide, Resin, Steel Bearings	16" x 1.75" Wide, Resin, Steel Bearings	16" x 1.75" Wide, Resin, Steel Bearings	14" x 1.75" Wide, Resin, Steel D-Bore
<b>Handlebars</b>	Straight	Ergonomic	Ergonomic	Ergonomic
<b>Frame</b>	14 Gage Steel	14 Gage Steel	14 Gage Steel	14 Gage Steel
<b>Mow-Ball</b>	4" Diameter, Super-Tough Nylon	4" Diameter, Super-Tough Nylon	4" Diameter, Super-Tough Nylon	4" Diameter, Super-Tough Nylon
<b>Drive Belt</b>	V-Belt, 3L, Gates PoweRated 6744, No Substitutions	V-Belt, 3L, Gates PoweRated 6744, No Substitutions	V-Belt, 3L, Gates PoweRated 6744, No Substitutions	V-Belt, 3L, Gates PoweRated 6744, No Substitutions
<b>Drivetrain</b>	N/A	N/A	N/A	Auto Clutching Transmission, Gates 1330 3L V-Belt, #35 Steel Chain, 10 Tooth to 40
<b>Machine Dimensions</b>	50.4" L x 21.5" W x 38.3" H	50.4" L x 21.5" W x 40" H	50.4" L x 21.5" W x 40" H	50.4" L x 21.5" W x 40.25" H
<b>Machine Weight</b>	57 Lbs Manual Start, 63 Lbs Electric Start	58 Lbs Manual Start, 65 Lbs Electric Start	60 Lbs Manual Start 67 Lbs Electric Start	79 Lbs Electric Start
<b>Accessories</b>	12" Beaver Blade, DR DuraBlade, TrimSafe Guard, and Weather Cover	12" Beaver Blade, DR DuraBlade, TrimSafe Guard, and Weather Cover	12" Beaver Blade, DR DuraBlade, TrimSafe Guard, and Weather Cover	12" Beaver Blade, DR DuraBlade, TrimSafe Guard, and Weather Cover

## Hardware Supplied in Hardware Bag

Part#	Description	Qty
15233	Nut, Nylon Lock, 7/16-20, LP *	2
16413	Nut, Nylon Lock, 3/8-16, LP **	2
11239	Washer, Flat, 3/8" USS **	2
32338	Washer, Flat, .510" X .875" X .1", ZP **	2

\* Non Self Propelled machines only

\*\* Self Propelled machines only

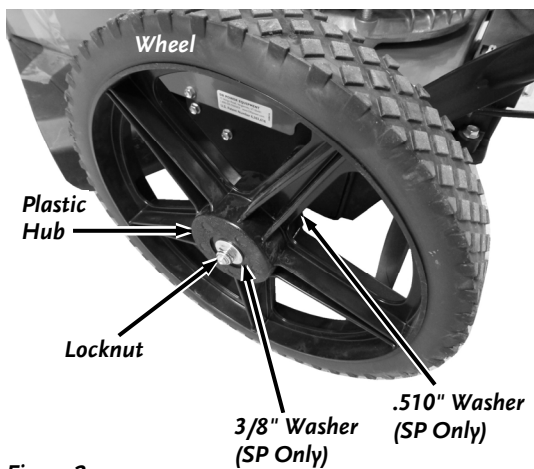

Figure 2

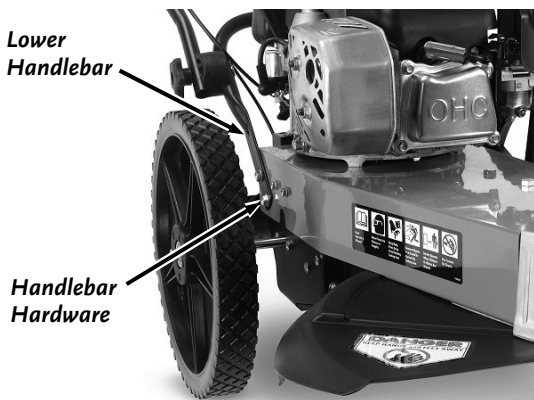

Figure 3

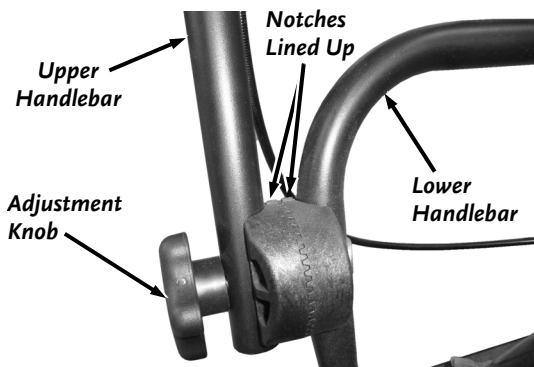

Figure 4

FOR PROPER SETUP OF YOUR NEW DR TRIMMER/MOWER PERFORM ALL THE FOLLOWING STEPS IN THIS CHAPTER.

### Installing the Wheels

Tool needed:

- 9/16" Wrench SP (Self Propelled)
- 5/8" Wrench Non SP (Non Self Propelled)

1. Remove the Locknuts (SP and Non SP) and washers (SP) from the Hardware Bag.
2. SP only: Insert a 5/16" X .875" X .1" Washer (#32338) onto the Axle (**Figure 2**).
3. Slide the wheel onto the axle with the plastic hub facing out.
4. SP only: Insert a 3/8" Washer onto the Axle against the outside of the Wheel.
5. Install a 7/16-20 Locknut with a 5/8" Wrench (#15233 Non SP) or a 3/8-16 Locknut with a 9/16" Wrench (#16413 SP).
6. Repeat for the other wheel.

### Adjusting the DR TRIMMER/MOWER Handlebar

#### NOTICE

The Lower Handlebar may have been loosened during shipping. Make sure that the Bolts attaching the Lower Handlebar to the Frame are tight.

Tool needed:

- 1/2" Wrench

Check the tightness of the four Bolts that secure the Lower Handlebar to the Frame using a 1/2" Wrench (**Figure 3**).

The Handlebar folds down for easy storage and the DR Trimmer/Mower is shipped to you with them folded.

**Note:** Ensure that the teeth of the Handlebar Adjusters mesh correctly as you tighten the Knobs in the following step.

1. Loosen both the Adjustment Knobs and move the Handlebar up or down until the Notches on the Adjusters are aligned on both sides and tighten the Knobs (**Figure 4**). This puts the Handlebar at a comfortable operating position for many people.

It is important to find a Handlebar height that allows the Mow-Ball® to comfortably hover just above the ground. When in use, proper adjustment is critical to best performance. You may find you like different Handlebar heights for different mowing conditions.

2. For other Handlebar height settings, loosen the Knobs, move the Handlebar up or down until you are comfortable, and then tighten the Adjustment Knobs securely. Take note of how many teeth you have moved away from the aligned notches to align both sides.



## Installing the Cutting Cords

There are two installation points on each Line Plate. Each point is 180 degrees apart. Always install two Cords, one opposite the other at the same height.

**Note:** Soaking the Cutting Cords and trimming the ends at an angle will make installation easier.

1. Insert the ends of the Cords into the side openings in the Line Plate (**Figure 5**).
2. Push the Cord through until the ends come out the center hole in the Line Plate. Adjust the Cords so the tips are even.
3. Pull the Cords under the loop and push the loop up into the Line Plate groove above them (**Figure 6**) and then pull the Cords tight.

### NOTICE

If the tips of the cords are not even, it can cause unbalance of the trimmer and will result in increased vibration.

**Figure 7** illustrates the Cords installation on the Line Plates. It shows the Line Plate from a top view. It may look complicated, but once you have done it a couple of times, it's easy. There are two installation points on each Line Plate. Each point is 180 degrees apart. Always install two Cords, one opposite the other.

## Extending Cutting Cord Life

- **STORE YOUR CORD OUT OF THE SUN.** UV can damage your cord causing premature wear.
- **KEEP YOUR CORD HYDRATED.** Soak your cord in water for at least 3 days before using.

## Adding Oil and Gasoline

**Note:** Refer to the Engine Manufacturers Manual for more detailed Engine information.

**Tip:** To avoid confusion, we recommend leaving the caps ON the Fuel and Oil Fills until you are ready to pour either gasoline or oil into the correct Fill.

**Note:** Use only SAE 30 high detergent oil classified "For Service SF, SG, SH, SJ" or higher. Do not use special additives. Other types of oil could cause problems with the operation of your machine. Please refer to your Engine Owner's Manual for detailed information on oil quantity and cold temperature oil specifications.

### NOTICE

- You must add oil before starting the engine. This machine is shipped without oil. Traces of oil may be in the reservoir from factory testing, but **you must add oil before starting the engine**. Fill the reservoir slowly, checking the level frequently to avoid overfilling.
- To get an accurate reading when checking the oil level:
  - the machine must be on a level surface with support under the Mow-Ball to ensure the Frame and Engine is level.
  - the dipstick must be screwed down to ensure an accurate oil level reading.

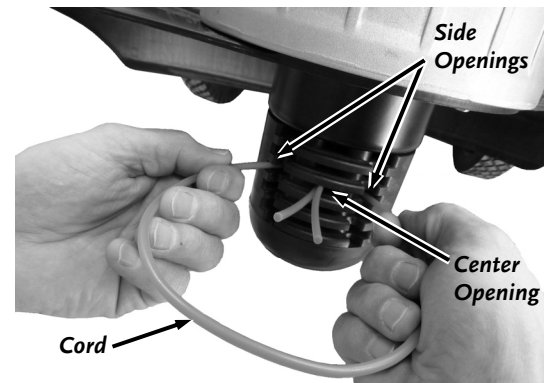

Figure 5

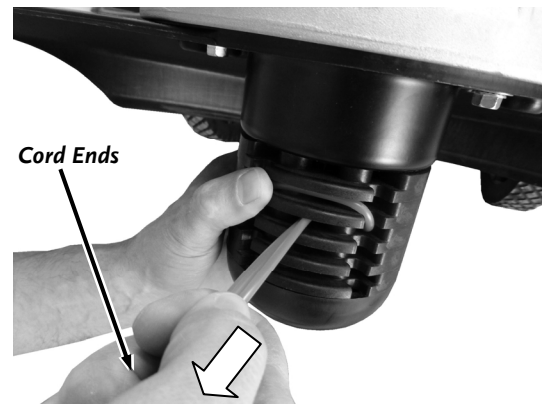

Figure 6

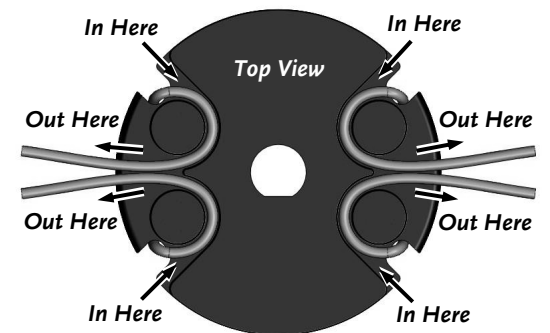

Figure 7

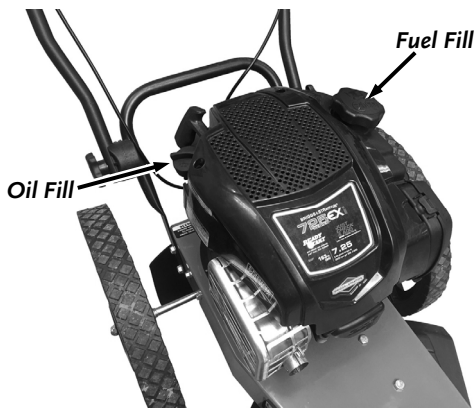

Figure 8

1. Position the machine on a level surface and Locate the Oil and Fuel Fills (Figure 8).

**Note:** Do not let the Mow-Ball rest on the ground because the Frame and Engine will be at too great an angle for a proper Oil level reading (Figure 9).

2. Place a support (wood block or similar) under the Mow-Ball so the Frame and Engine are level (Figure 10).
3. Open the Oil Fill Cap and initially add half of the recommended SAE 30 High Detergent oil into the Oil Fill and wait one minute for the oil to settle (Figure 8). See your Engine manual for recommended Oil amount.
4. Fully install the Dipstick and then remove it to recheck the Oil level (Figure 11). Continue adding a small amount of oil at a time, rechecking the Dipstick until the oil level is in middle of the hatched area (between the ADD and FULL holes in the Dipstick). Be careful not to overfill.

**PROPER LEVEL:** Middle Of Crosshatched Area between holes.

**LOW:** Only Add Oil If It Is Below The Lower (ADD) Dipstick Hole.

**HIGH:** Remove Oil If It Is On Or Above The Upper (MAX) Dipstick Hole.

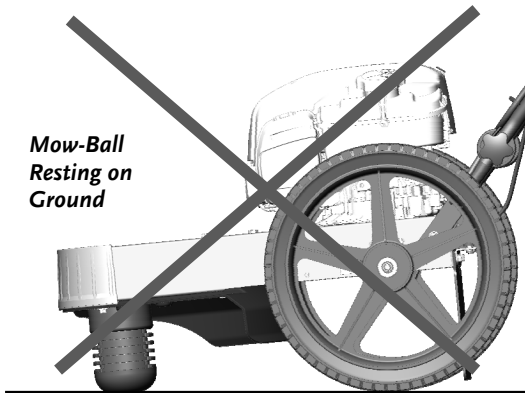

Figure 9: Not Level

### **! WARNING**

Fill the fuel tank outdoors or in a well-ventilated area, away from sparks, open flames, pilot lights, heat, and other ignition sources.

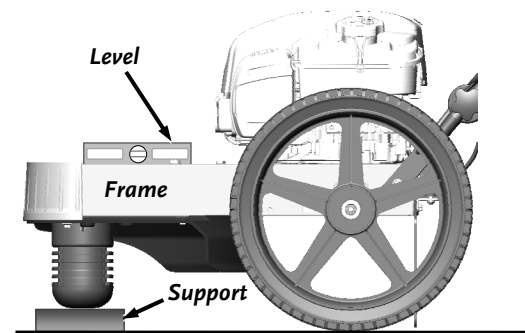

Figure 10: Level

5. Fill the Fuel Tank with fresh, unleaded gas (with a minimum of 85 Octane and no more than 10% Ethanol), to not more than 1/4" from the bottom of the Fill Neck to allow for Fuel expansion (Figure 8). Be careful not to overfill and reinstall the Cap before starting the Engine. See your Engine Owner's Manual for more information.

**Note:** To refill the Fuel Tank, turn the Engine OFF, and let the Engine cool at least two minutes before removing the Fuel Fill Cap.

### **Connecting the Battery Wire (Electric-Starting Models Only)**

We ship all Electric-Starting Trimmers with the negative Battery wire disconnected. This prevents the Battery from discharging during shipment. Before using your Trimmer, you must connect the Battery wire.

1. Connect the black wire by pushing the Connector onto the negative (-) Battery terminal (Figure 12).

**Note:** The red wire should already be attached to the positive terminal.

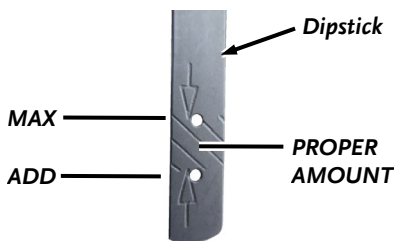

Figure 11

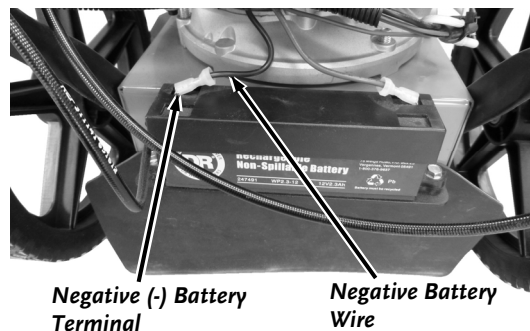

Figure 12

## Chapter 3: Operating the DR TRIMMER/MOWER

### **! WARNING**

- The design of your machine is for trimming and mowing grass, weeds, and other growth as specified in this manual. Do not use it for any other purpose as it could cause serious injury.
- Contact with internal rotating parts will cause serious personal injury. Never put hands, face, feet, or clothing under the mower deck or discharge opening at any time.
- Before performing any adjustments to the trimmer cords or any other procedure or inspection, stop the engine, wait five minutes to allow parts to cool. Disconnect the spark plug wire, keeping it away from the spark plug.

### **Before Starting the Engine**

1. Check the oil level every time you use the DR TRIMMER/MOWER (**Figure 13**).
2. Check the fuel level.
3. Remove any debris buildup from the top of the Engine and the underside of the machine.

### **! CAUTION**

It is important for proper operation to keep the top of the engine clear of grass and debris at all times so the engine can pull air through to stay cool. If the top of the engine is clogged then the engine could overheat causing engine damage.

**Note:** See the Engine Manual for more detailed and specific information on operating the Engine.

### **Manual Starting**

**Note:** You may use these starting methods with both Manual and Electric-Starting models.

1. Push the Throttle Control Lever all the way forward to the Run  position (**Figure 13**).
2. Grasp the Recoil Starter Handle and slowly pull until you feel resistance. Let the cord retract a little bit and then pull the cord rapidly to start the Engine. One or two pulls usually starts the DR TRIMMER/MOWER.

**Note:** Do not engage the Bail Bar (Trimmer Head Control) until after the Engine has started.

### **Electric Starting**

### **NOTICE**

- The 6.75 and 7.25 EXI Engines are not equipped with alternators. Running the Trimmer Engine will NOT recharge your Battery. Charge the Battery after each use by following the Instructions on page 25.
- If the engine fails to start after TEN (10) seconds of continuous cranking, turn the key to the off position and allow the starter motor to cool. Check the cause of hard starting; See Chapter 5 - Troubleshooting.

**Note:** Use the following steps with Electric-Starting models only.

1. Push the Throttle Control Lever all the way forward to the Run  position (**Figure 13**).
2. Turn the Key to the START position until the Engine starts, then release. The Key will snap back to the RUN position and the Engine will continue to run.

**Note:** Do not engage the Trimmer Head Engage Bar until after the Engine has started.

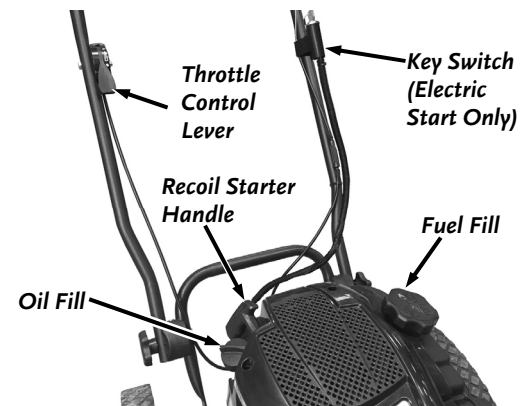

Figure 13

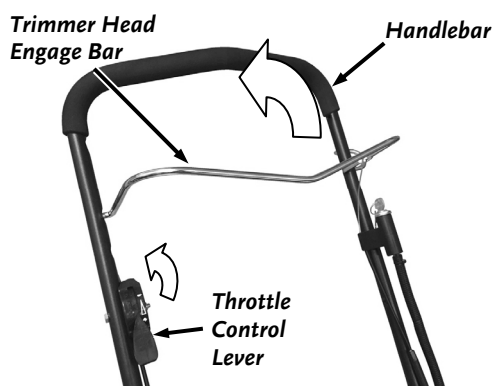

Figure 14

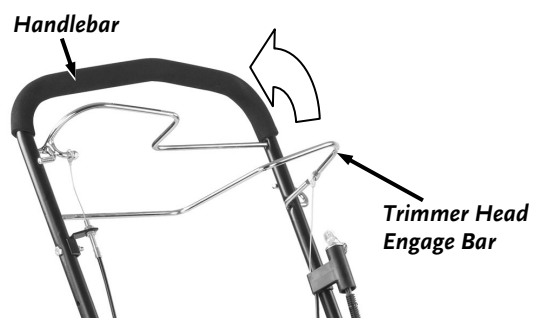

Figure 15

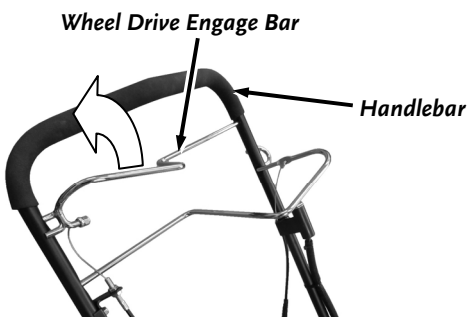

Figure 16

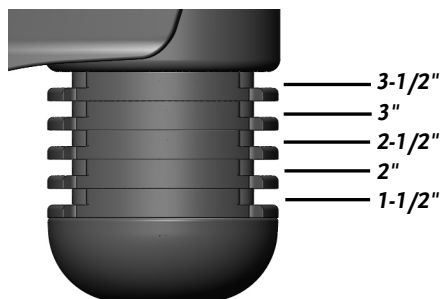



Figure 17

## Stopping the Engine

1. Move the Throttle Control Lever (**Figure 14**) all the way back past the Idle  position.

**Note:** If you have an Electric-Starting model, please note that the Key does not stop the Engine. You must follow these instructions to stop the Engine for both Electric and Manual-Starting models.

2. Remove the Key for safety. If the Key becomes difficult to remove, apply SAE 30 Oil into the Keyhole.

## Engaging the Trimmer Head

1. Bring the Trimmer Head Engage Bar toward you and grip it together with the Handlebar (non self propel **Figure 14**) (Self Propel **Figure 15**). Keep holding the Bar to the Handlebar. The Cutting Cords will rotate and will continue to rotate until you release the Bar.

**Note:** Before using your Trimmer for the first time or after you have installed a new Belt, engage the Trimmer Head Engage Bar 10 times and hold it for 3 seconds each time. This is required to wear in the Belt to ensure the best grip for trimming.

## Stopping the Cords from Spinning

1. Release the Trimmer Head Engage Bar from the Handlebar. The Trimmer Head will stop spinning while the Engine continues to run.

## Engaging the Self Propol Wheel Drive

1. Bring the Wheel Drive Engage Bar toward you and the Handlebar (**Figure 16**). The closer to the Handlebar you move the Bar the faster the machine will travel. The machine will continue to move forward until you release the Bar.
2. Push the Trimmer forward a little after releasing the Wheel Drive Engage Bar. This unlocks the Wheel Transmission Clutches so you can pull the Trimmer back easily.

## Setting the Cutting Height

Setting the Cutting Height is easy. Cutting heights range in 1/2-inch increments from 1-1/2 inches (minimum) when using the bottom Line Plate, to approximately 3-1/2 inches when using the top Line Plate (**Figure 17**).

Install the Cutting Cords in the Line Plate that gives you the desired cutting height.

## Installing the Cutting Cords

### WARNING

Before performing any adjustment, maintenance procedure or inspection, stop the engine, wait five minutes to allow parts to cool and disconnect the spark plug wire, keeping it away from the spark plug.

### NOTICE

Running the trimmer with only one cord installed, cords of unequal length or cords installed at other than 180 degrees apart can cause excessive vibration and may damage the machine.

For more detailed information refer to “Installing The Cutting Cords” section in Chapter 2.

**Note:** After you install the Cords, and before trimming, engage the Cutting Head with the Engine running to spin the new Cords for a few seconds so they pull tight and are set.

1. Insert the ends of the Cord into the side openings in the Line Plate (**Figure 18**).
2. Push the Cord through until the ends come out the center opening in the Line Plate. Adjust the ends so the tips are even.
3. Pull the ends of the Cord under the loop and push the loop up into the Line Plate groove above them (**Figure 19**) and then pull the ends tight.

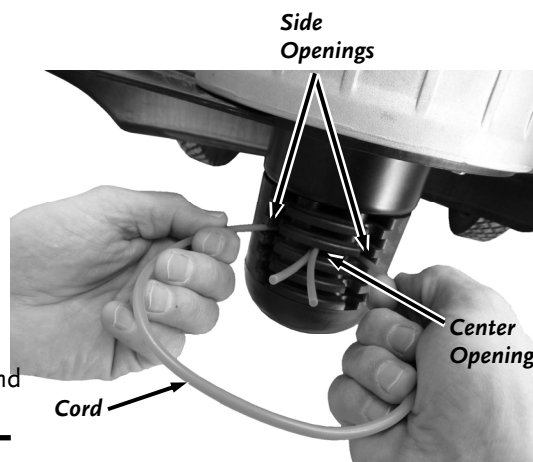

Figure 18

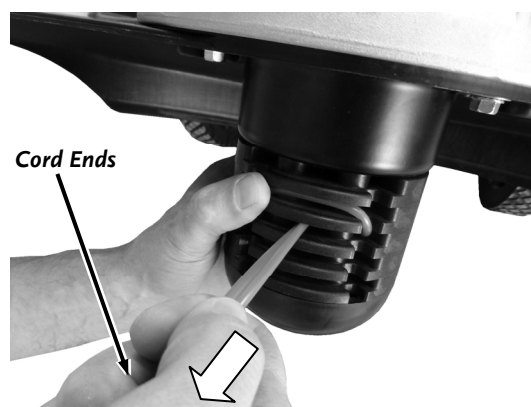

Figure 19

## **Cord Tips**

We ship two (2) thicknesses of Cutting Cord with your DR TRIMMER/MOWER.

The Cords are Blue (175-mil) and Green (155-mil). Because conditions and vegetation vary so much, you should experiment with Cord weights (diameters) to discover what works best for your particular mowing and trimming situations. Here are a few things to keep in mind:

- If you buy Cutting Cord in rolls, cut it in 25" lengths. Cut them at an angle so they will be easier to install.
- Soak your Cutting Cord in a bucket of room temperature water for a few days before use to make it more pliable. Storing the Cord in a plastic bag with a damp sponge or cloth will help keep it pliable
- Cord life depends on trimming conditions. Replace Cords when they become broken or frayed.
- The smallest diameter Cord capable of cutting the material at hand combined with the fastest Engine speed usually provides the best grass trimming performance. When you need more power for thicker growth such as berry canes, brambles, thistles, or ragweed, you may want to use the 175-mil Cord in combination with the highest Engine speed.
- Ease the ends of the Cord into heavy growth and move slowly through thick growth. If there are woody weeds in the material you are cutting, the cutting Cords may wrap around the stalks they cannot cut, and pull away from the Trimmer Head.
- Please note that installing more than two (2) Cords at a time does not improve trimming performance, in fact, it can lessen it. Adding additional Cords creates drag on the Trimmer Head, robs the Engine of power, and may cause wrapping. Installing two (2) Cords, 180 degrees apart, on the same line plate, is the best method for optimal trimming performance.
- When replacing Cords, do it one at a time and use the old Cord to mark the position for the new Cord that you are replacing.
- If the Cord breaks off flush at the Line Plate, use needle nose pliers to pull out the old Cord.
- UV light can degrade cord, store out of direct sunlight.



**Figure 20**

### ***The Mow-Ball®***

Allow the front end of the machine to rest lightly on the Mow-Ball® or keep the mow ball raised slightly above the ground as you are trimming. When mowing the Mow-Ball should glide on the ground as you maneuver the machine. To achieve the best and smoothest cut, do not lift up on the Handlebar while operating your DR TRIMMER/MOWER. Lifting the Handlebar will force weight down on the Mow-Ball®. This uses more energy, slows the cutting, and produces an unsatisfactory cut (**Figure 20**).

### ***Self Propel Wheel Drive***

- When trimming with an in and out "vacuum cleaner" motion, be sure to release the Wheel Engage Bar before pulling the Trimmer backwards.
- Push the trimmer forward a little after releasing the Wheel Drive Engage Bar. This unlocks the wheel transmission clutches so you can pull the Trimmer back easily.

## Obstacles

Dealing with obstacles in the terrain is easy with your new DR TRIMMER/MOWER. The following section explains how to approach most common obstacles.

### WARNING

The trimmer engine's power can easily throw stones, sticks, and other debris at great velocity, which could cause personal injury or property damage. Do not run the machine over gravel driveways or over loose stones or mulch with the trimmer head spinning.

**Tip:** The DR TRIMMER/MOWER discharges cut material to the right. Always try to cut and trim with the uncut tall grass or weeds on the left.

- Always check your work area before trimming and remove any debris that might tangle or damage the machine.
- If you do run into debris and the Trimmer becomes tangled, turn off the Engine and disconnect the Spark Plug wire before attempting to untangle the machine.
- For the neatest appearance, do your trimming first, discharging clippings away from borders and shrubs, then do your mowing.
- Many owners like to mow easy, open areas with their regular riding or walk-behind mower and finish trimming all the odd and hard-to-reach spots with the DR TRIMMER/MOWER (*Figure 21*).

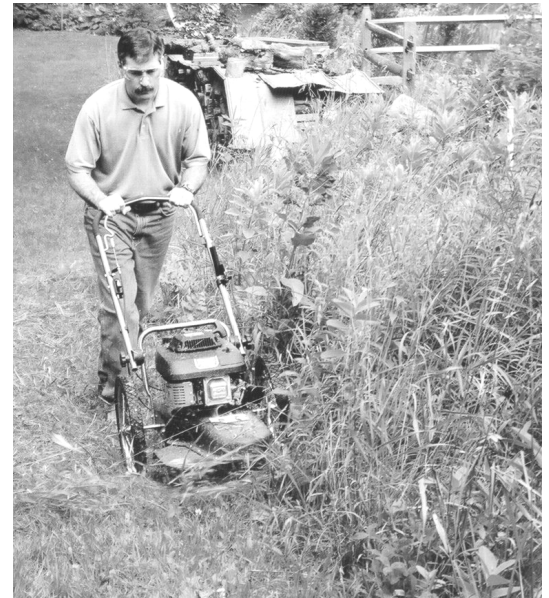

*Figure 21*

## Heavy Growth

- Take your time in heavy growth.
- Be sure to keep uncut material to your left, maintaining a clear discharge area to your right (*Figure 22*).
- If the machine cannot do it all in one pass, overlap half of the cutting swath.
- If the grass is very thick and heavy, try raising the Trimmer Head off the ground a few inches by pushing down on the Handlebar. Cut the material at this height, and then make a second pass with the Mow-Ball® close to the ground.
- Ease the DR TRIMMER/MOWER into denser growth. If the material is too tough or woody to cut, the Cutting Cords will wrap around it, wear down, or even break off.
- Sometimes the growth is so heavy, you cannot mow it in rows. Use a forward and back “vacuum cleaner” motion in these cases.

**Tip:** Use the “two pass”, one half overlap method, whenever possible.



*Figure 22*



Figure 23

### Wet Conditions

#### **CAUTION**

Make sure of your footing when operating in wet conditions.

Because there is no housing to restrict the flow of cut material, you can also use your DR TRIMMER/MOWER to mow wet or heavy growth. You can use the DR in damp conditions, after a rain, or in the early morning dew without clogging or stalling. You can also mow wet areas such as ditches and around ponds (**Figure 23**).

**Note:** NEVER mow in the rain. Water on the Spark Plug may cause the Engine to stall.

### Very Dry Conditions

#### **NOTICE**

Frequently remove debris from the recoil guard on top of the engine and the cooling fins on the front of the engine to prevent overheating and engine damage.

When trimming and mowing in very dry conditions, be extra cautious of cut grass, chaff, weeds, seeds, etc., accumulating on the Engine, especially around the Recoil-Starter Housing and Engine Cooling Fins. Please see the Engine Owner's Manual for more detailed information on cleaning the Air Intake, Air Filter, and Cooling System on the Engine.

### Slopes

#### **CAUTION**

Make sure of your footing when operating on slopes.

You can trim and mow on slopes up to 20 degrees. Continuous use on slopes steeper than 20 degrees may deprive the Engine of adequate lubrication, and damage components.

### Windrows

The DR TRIMMER/MOWER Cutting Cords cut even tall grass in just one pass, so you can collect clippings and leaves for mulch without raking. The machine ejects cut material to its right side, so you can use it like a lawn broom to make windrows for easy clean-up.

### Firebreaks

Use your Trimmer as a labor saving tool to cut material when creating firebreaks.

### Garden Clean-Up

The DR TRIMMER/MOWER is perfect for cutting down dead perennials, annuals, and wildflowers, saving you hours of hand pruning and deadheading. You can also re-cut downed material a second time to create mulch for garden beds.



## Chapter 4: Maintaining The DR TRIMMER/MOWER

Regular maintenance is the way to ensure the best performance and long life of your machine. Please refer to this manual and the engine manufacturer's owner's manual for maintenance procedures. Service intervals listed in the checklist below supersede those listed in the engine manufacturer's owner's manual.

### **⚠ WARNING**

Before performing any maintenance procedure or inspection, stop the engine, wait five (5) minutes to allow all parts to cool. Disconnect the spark plug wire, keeping it away from the spark plug.

### **Regular Maintenance Checklist**

**Note:** Consider that the service intervals shown are the maximum under normal operating conditions. Increase frequencies under extremely dirty or dusty conditions.

PROCEDURE	BEFORE EACH USE	EVERY 25 HOURS	EVERY 50 HOURS	EVERY 100 HOURS
Check Engine Oil Level and add as needed.	▲			
Clean Engine Exterior, Cooling Fins and remove collected grass trimmings.*	▲			
Check General Equipment Condition, e.g. Nuts, Bolts, Welds, etc.	▲			
Replace broken or frayed Cutting Cords.	▲			
Check the Mow-Ball® Line Plates for excessive wear.	▲			
Check the Trimmer Belt for stretching. Adjust the Drive Cable if necessary per "Adjusting the Trimmer Belt Tension through the Trimmer Control Cable" in this Chapter.	1 <sup>st</sup> time 2 hours	▲		
Lubricate Throttle Cable, Self Propel Cable and Trimmer Control Cable with SAE 30 Oil.		▲		
Replace the Engine Air Filter Cartridge and foam Pre Filter if equipped.		▲		
Remove the Trimmer Guard and clean out any collected debris		▲		
Check the Battery Voltage (Electric-Starting models)		▲		
Lubricate Chains (Self Propelled models)		▲		
Replace the Trimmer Belt			▲	
Replace the Self Propel Belt (Self Propelled models)			▲	
Replace the Spark Plug.				▲

\* Cleaning the top of the Engine during use is critical for proper air flow. Keeping the Engine clear of debris is necessary for optimum performance.

### **Replacing the Mow-Ball® or Line Plates**

#### **Tools and Supplies Needed:**

- Phillips head Screwdriver with at least a 6" shank
- Gloves

#### **Disassembly**

1. Align the hole in the Anti Wrap Canister with the hole in the internal housing at the location shown (**Figure 24**).
2. Insert a Philips Head Screwdriver into the hole in the Anti Wrap Canister and the hole in the internal Housing.
3. Rotate the Mow-Ball® Assembly until the Screw Driver slides into a hole in the shaft, locking it into place.

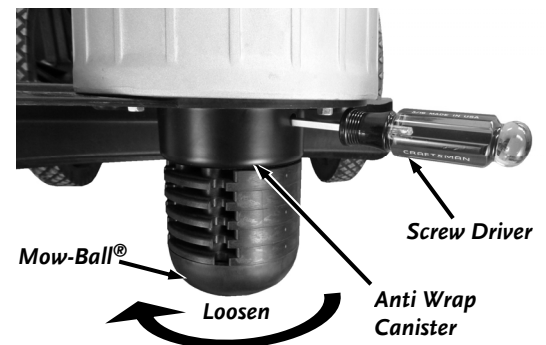

**Figure 24**

4. Looking down at the top of the Frame, turn the Mow-Ball® clockwise until it unscrews completely from the Bearing Housing.

**Note:** If the Mow-Ball® continues to turn, but does not come off, check to be sure that you locked the Screwdriver into the shaft.

If the Mow-Ball will not turn by hand a 9/16" Socket can be used on the Bolt (inside the bottom of the Mow-Ball) to loosen it. You may need to clean grass or debris out of the recess first.

5. Slide the Line Plates, Anti Wrap Canister and Spacer off the Shaft (**Figure 25**).

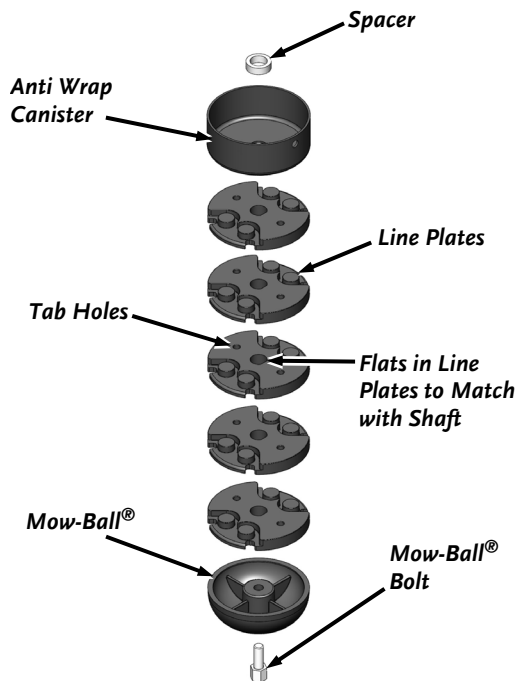

Figure 25

### Assembly

#### NOTICE

Improper installation can cause damage to the trimmer bearings. Follow these directions carefully to protect your machine from damage. Reassemble the components in the order shown in **figure 25**.

1. Place the Spacer and Anti Wrap Canister (with the lip facing up) onto the Shaft (**Figure 25**).
2. Ensure the Line Plates are facing top side up as shown. Align the flats at the center of the Line Plates with the flat on the shaft as you slide them onto the Shaft. Ensure the Tabs on the underside of the Line Plates are fully into the holes on the tops of the Line Plates so they will fit together tightly.
3. Place the head of the Mow-Ball® Bolt so it is sitting in the hex cavity at the bottom of the Mow-Ball®.
4. Looking down at the top of the Frame, hold the Bolt Head in place with your finger and turn the Mow-Ball® counterclockwise to start the Bolt into the Shaft.
5. Tighten the assembly securely by turning the Mow-Ball® counterclockwise when looking down on the top of the Frame.
6. Remove the Screwdriver.

**Note:** When finished there should be no gaps between any of the components.

#### ! WARNING

Always make sure you remove the screwdriver from the head assembly when finished. Failure to remove the screwdriver could cause injury when the head assembly is engaged.

## Replacing the Trimmer Head Belt (non Self Propelled models)

### NOTICE

Use only DR belts on your machine. Do not use hardware store variety belts.

#### Tools and Parts needed:

- 3/8" Wrench
- 9/16" Wrench

1. Tip the machine back to access the underside.
2. Remove the Trimmer Cords from the Head Assembly.
3. Remove the four Trimmer Guard Bolts and Flat Washers with a 3/8" Wrench. Remove the Trimmer Guard (**Figure 26**).
4. Remove the Locknut that secures the Washer Plate to the flat groove Idler Pulley using a 9/16" Wrench (**Figure 27**). Loosen the other Locknut to the V groove Idler Pulley using a 9/16" Wrench just enough so the Washer Plate can be rotated out of the way.
5. Remove the flat Idler Pulley and Spacer behind it.
6. Remove the Belt from around the Engine and Head Assembly Pulleys.

**Note:** You should be able to remove the Belt with the Engine Belt Guide in place, but if not, remove the Engine Belt Guide Bolts using a 9/16" Wrench to remove the Guide.

7. Install a new DR Drive Belt around the Engine and Head Assembly Pulleys.
8. Install the Engine Belt Guide if it was removed.
9. Install the small Spacer first, then the Flat Groove Idler Pulley with the Belt in the groove. Make sure you place the Belt correctly between the Idler Pulley, Bracket Tab, and Guide Pin (**Figure 28**).

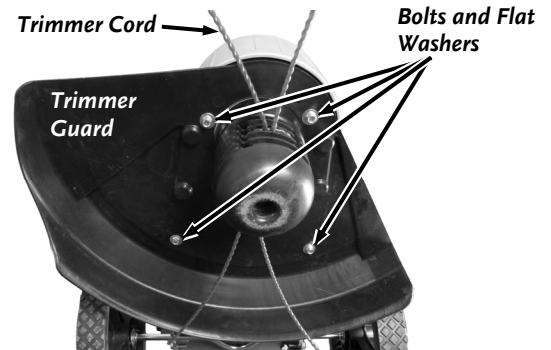

Figure 26

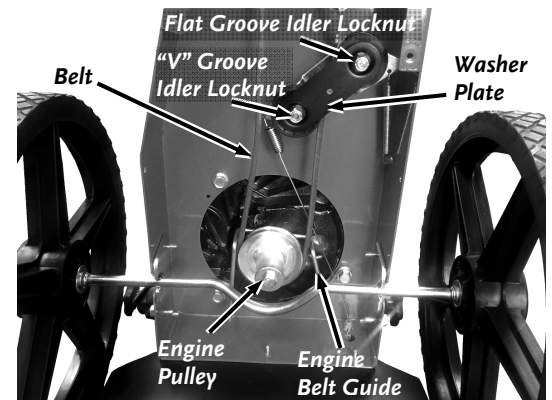

Figure 27

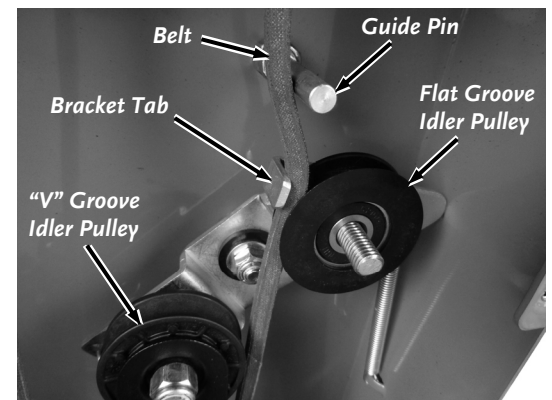

Figure 28

### CAUTION

The Belt must be installed on the inside of the guide Pin as shown in figure 25. If it is not installed on the inside the Trimmer Head will not function correctly.

10. Rotate the Washer Plate onto the Flat Groove Idler Stud and install the Locknut using a 9/16" Wrench (**Figure 27**). Tighten both Idler Locknuts using a 9/16" Wrench.
11. Position the Trimmer Guard and secure with the four Bolts and Flat Washers using the 3/8" Wrench (**Figure 26**).
12. Install the Trimmer Cord and tip the Trimmer down on the Head Assembly.
13. After installing the new Belt, be sure to adjust the tension properly by adjusting the In-Line Adjuster all the way in (refer to page 24). Proper tension will extend the life of the Belt.

**Note:** Before using your Trimmer for the first time or after you have installed a new Belt, engage the Trimmer Head Engage Bar 10 times and hold it for 3 seconds each time. This is required to wear in the Belt to ensure the best grip for trimming.

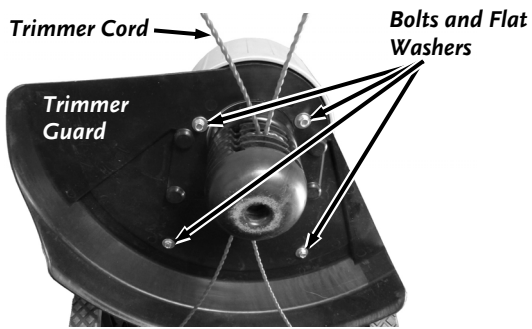

Figure 29

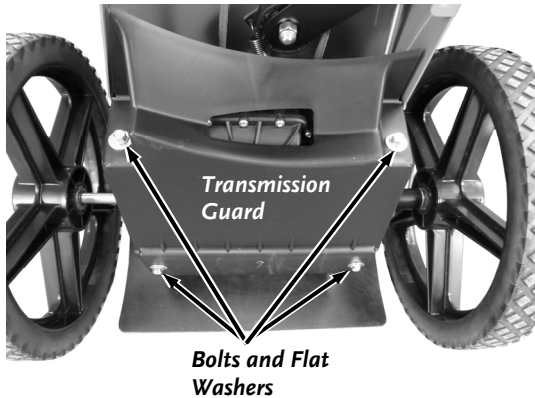

Figure 30

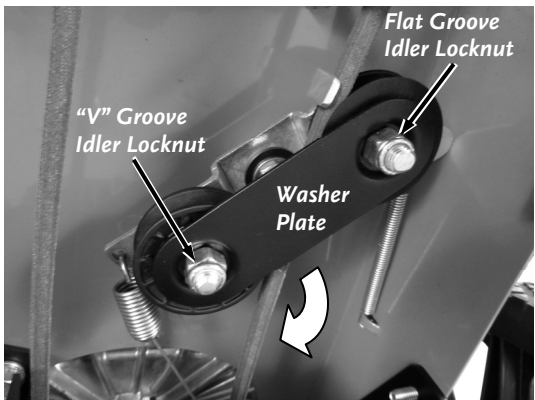

Figure 31

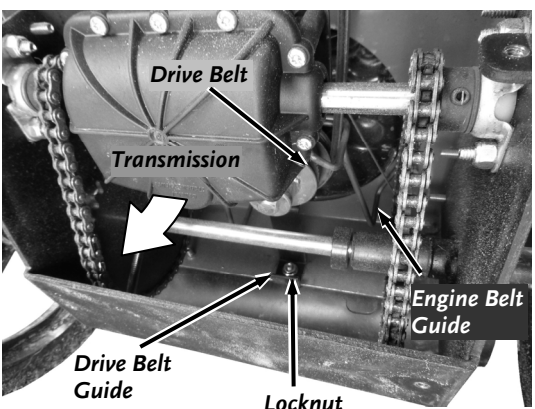

Figure 32

## Replacing the Trimmer Head Belt (Self Propelled model)

### Tools needed:

- 3/8" Wrench
- 7/16" Socket w/Ratchet
- 9/16" Wrench

1. Tip the machine back onto the handlebar to access the underside.
2. Remove the Trimmer Cords from the Head Assembly.
3. Remove the four Trimmer Guard Bolts and Flat Washers with a 3/8" Wrench. Remove the Trimmer Guard (**Figure 29**).
4. Remove the four Transmission Cover Bolts and Flat Washers with a 3/8" Wrench (**Figure 30**). Remove the Transmission Cover.
5. Remove the Locknut that secures the Washer Plate to the flat groove Idler Pulley using a 9/16" Wrench (**Figure 31**). Loosen the other Locknut to the V groove Idler Pulley using a 9/16" Wrench just enough so the Washer Plate can be rotated out of the way.
6. Loosen the Drive Belt Guide Locknut at the rear of the Frame using a 7/16" Socket w/Ratchet and rotate the Guide out of the way (**Figure 32**).
7. Rotate the Transmission down toward the back just enough to slide the small Drive Belt from the Engine Pulley
8. Remove the Trimmer Head Belt from around the Engine and Head Assembly Pulleys.
9. Install a new DR Trimmer Head Belt around the Engine and Head Assembly Pulleys.
10. Rotate the Transmission into position as you guide the Drive Belt into the Engine Drive Pulley groove.
11. Rotate the Drive Belt Guide at the rear of the Frame into position and tighten the Locknut with a 7/16" Socket w/Ratchet.

**Note:** Ensure that the Belts are positioned properly in reference to the Belt Guides (**Figure 33**).

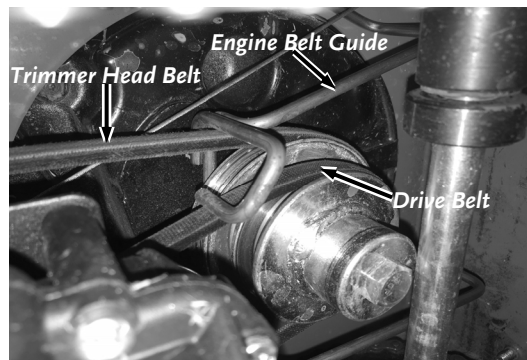

Figure 33

12. Install the small Spacer and flat Idler Pulley (**Figure 34**). Make sure you place the Belt correctly between the Idler Pulley, Bracket Tab, and Guide Pin.

### CAUTION

The Belt must be installed on the inside of the guide Pin as shown in figure 30. If it is not installed on the inside the Trimmer Head will not function correctly.

13. Rotate the Washer Plate onto the Flat Groove Idler Stud and install the Locknut using a 9/16" Wrench (**Figure 31**). Tighten the "V" Groove Idler Locknut using a 9/16" Wrench.
14. Install the Transmission Cover and secure with the four Transmission Cover Bolts and Flat Washers using a 3/8" Wrench (**Figure 30**).
15. Position the Trimmer Guard and secure with the four Bolts and Flat Washers using the 3/8" Wrench (**Figure 29**).
16. Install the Trimmer Cord and tip the Trimmer down on the Head Assembly.
17. After installing the new Belt, be sure to adjust the tension properly by adjusting the In-Line Adjuster all the way in (refer to page 24). Proper tension will extend the life of the Belt.

**Note:** Before using your Trimmer for the first time or after you have installed a new Belt, engage the Trimmer Head Engage Bar 10 times and hold it for 3 seconds each time. This is required to wear in the Belt to ensure the best grip for trimming.

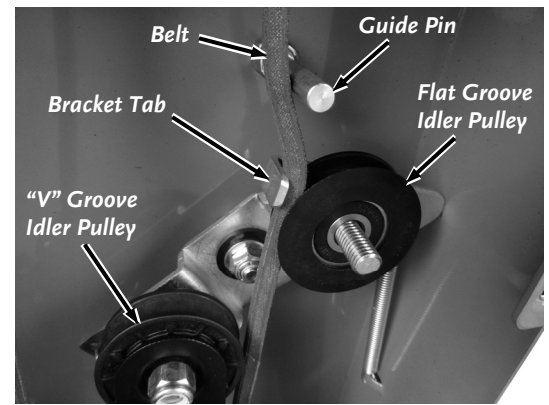

**Figure 34**

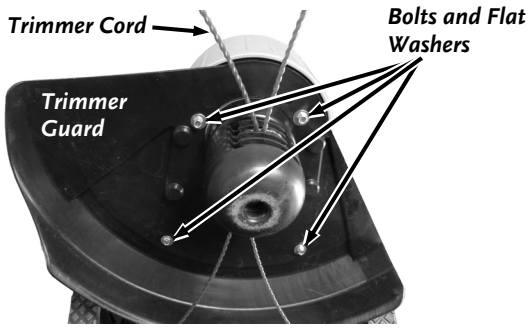

Figure 35

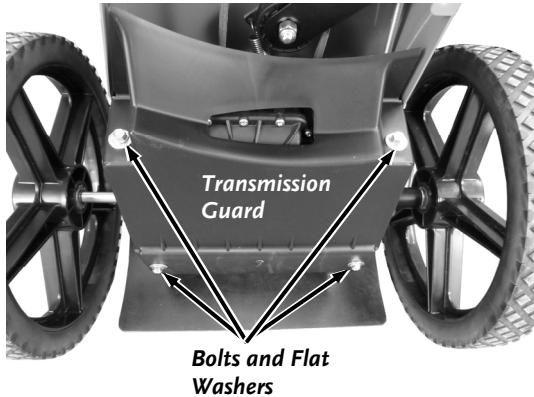

Figure 36

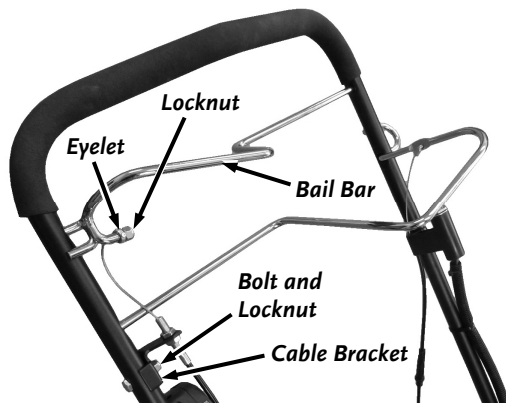

Figure 37

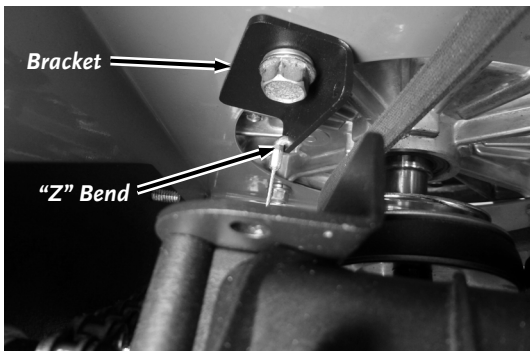

Figure 38

## Replacing the Drive Belt (Self Propelled model)

### Tools needed:

- 3/8" Wrench
- Two 7/16" Wrenches
- 7/16" Socket w/Ratchet
- Philips Head Screwdriver

1. Tip the machine back onto the handlebar to access the underside.
2. Remove the Trimmer Cords from the Head Assembly.
3. Remove the four Trimmer Guard Bolts and Flat Washers with a 3/8" Wrench. Remove the Trimmer Guard (Figure 35).
4. Remove the four Transmission Cover Bolts and Flat Washers with a 3/8" Wrench. Remove the Transmission Cover (Figure 36).
5. Remove the Locknut that is securing the Drive Cable Eyelet to the Bail Bar using a 7/16" Wrench and remove the Eyelet from the Bail Bar (Figure 37).
6. Remove the Cable Bracket from the Handlebar using two 7/16" Wrenches.
7. Disconnect the Z-bend end of the Drive Cable from the Bracket (Figure 38).
8. Loosen the rear Drive Belt Guide Locknut using a 7/16" Socket w/Ratchet and rotate the Guide out of the way (Figure 39).
9. Rotate the Transmission down toward the back enough to slide the small Drive Belt from the Engine Pulley groove.

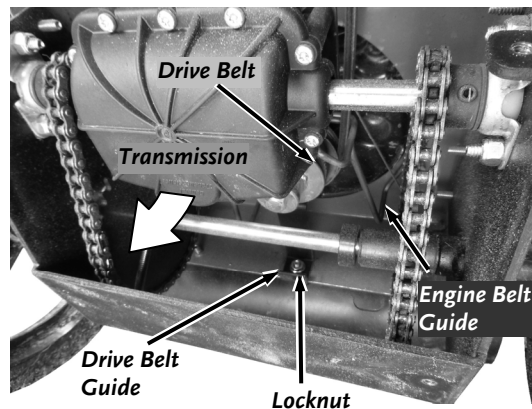

Figure 39

**Note:** Ensure that the Drive Cable does not kink or get over stressed during the following procedure.

The Belt Guide will interfere with the Transmission Housing and Belt when the Transmission is rotated. The Belt can be repositioned and the Belt Guide can be moved out of the way slightly as needed.

10. Continue to rotate the Transmission to gain access to the Belt retainers and Screws on the bottom of the Transmission (**Figure 40**).
11. Remove the two Retainer Screws where the Belt wraps around the Pulley and loosen the other two using a Philips Head Screwdriver.
12. Rotate the Belt retainers away from the Transmission Pulley and remove the Belt.
13. Install a new DR Drive Belt around the Transmission Pulley.
14. Rotate the Transmission Belt Retainers into position and secure with the two Screws you removed and tighten the other two using a Philips Head Screwdriver.
15. Rotate the Transmission and Belt up into the Trimmer and position the Drive Belt around the Engine Pulley.

**Note:** Ensure that the Belts are positioned properly in reference to the Belt Guides (**Figure 41**).

16. Rotate the rear Drive Belt Guide into position centered behind the Engine Pulley and tighten the Locknut with a 7/16" Socket w/Ratchet (**Figure 39**).
17. Reconnect the Z-bend end of the Drive Cable into the Bracket hole (**Figure 38**).
18. Reattach the Cable Bracket to the Handlebar using two 7/16" Wrenches (**Figure 37**).
19. Install the Drive Cable Eyelet to the Bail Bar using a 7/16" Wrench.
20. Install the Transmission Cover and secure with the four Bolts and Flat Washers using a 3/8" Wrench (**Figure 36**).
21. Position the Trimmer Guard and secure with the four Bolts and Flat Washers using the 3/8" Wrench (**Figure 35**).
22. Install the Trimmer Cord and tip the Trimmer down on the Head Assembly.
23. After installing the new Belt, be sure to adjust the Cable tension properly by adjusting the Jam Nuts (refer to page 25). Proper tension will extend the life of the Belt.

## Replacing the Wheels

**Tool needed:**

- 5/8" Wrench (non Self Propelled model)
- 9/16" Wrench (Self Propelled model)

1. Block and stabilize the machine so that the Wheels are off the ground.
2. Loosen and remove the Locknut with the required Wrench (**Figure 42**).

**Note:** The self propelled Wheel has a Flat Washer under the Locknut.

3. Slide the Wheel off the Axle.
4. Reverse the steps to install the new Wheel.

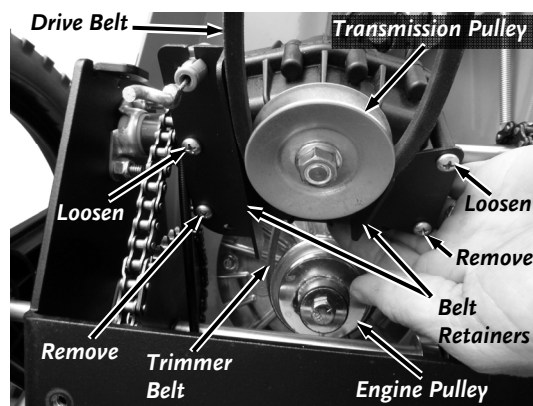

Figure 40

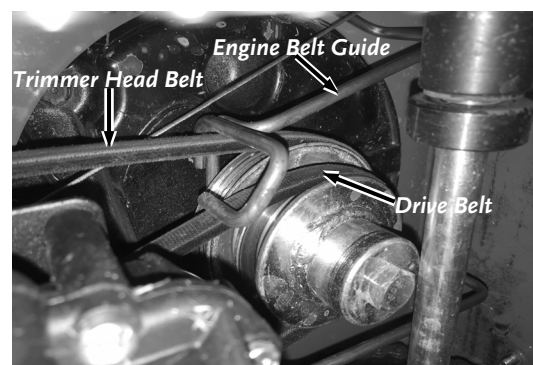

Figure 41

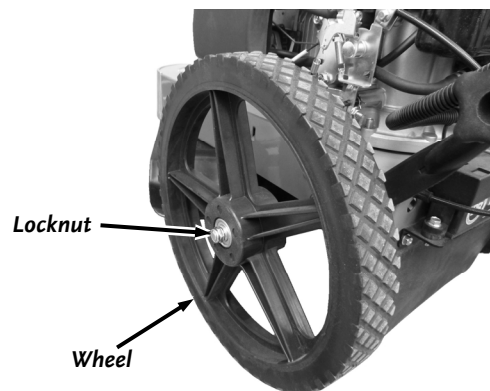

Figure 42

## Changing the Engine Oil

### Tools and Supplies needed:

- SAE 30 HD Oil (refer to your Engine Owner's Manual for quantity required)
- Suitable container for used oil
- Rags
- Wooden pallet or workbench

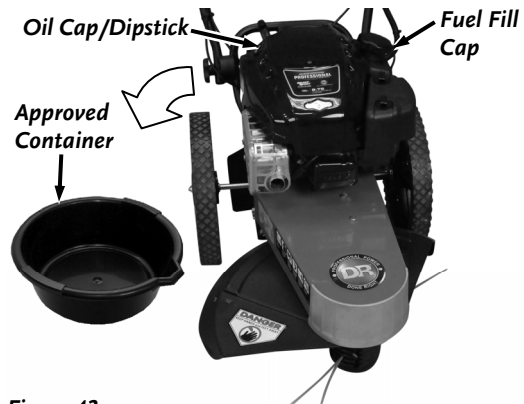

Figure 43

**Note:** The Briggs and Stratton 6.75 EXi, 7.25 EXi, and 8.75 Engines do not require a regular Oil Change. Check the Engine Oil before each use and add Oil as needed. Refer to the Engine Manufacturers Manual for more detailed Engine information.

**Note:** Drain the oil when the Engine is warm. Warm oil drains quickly and completely.

1. For convenience, place the machine up on a wooden pallet or workbench.
2. Remove the Oil Cap/Dipstick and position a suitable oil receptacle beside the Oil Fill Tube.
3. Make sure to securely tighten the Gas Fill Cap.
4. Using the handle of the DR TRIMMER/MOWER, tip the machine to drain the oil out through the Oil Filler Tube into a suitable receptacle (**Figure 43**).
5. Refill the Engine using SAE 30 HD oil to the level indicated on the Dipstick.

**Note:** Be sure to use environmentally safe disposal procedures in the disposing of the used oil.

## Adjusting the Trimmer Head Belt Tension through the Trimmer Control Cable

### NOTICE

Before adjusting the trimmer head belt tension cable, check that the belt is properly installed. Also make sure the Cable is attached to the bail bar.



Figure 44

The Belt will stretch a little when new, then more over time. If the Trimmer Head does not spin with the Trimmer Head Engage Bar engaged, adjust the Trimmer Control Cable to put more tension on it. The Adjuster is located on the Control Cable itself.

1. Locate the Trimmer Head Cable along the left Handlebar. There is an In-Line Adjuster to change the tension on the Cable (**Figure 44**).

**Note:** There are two different styles of In-Line Cable Adjusters. One has a hex at one end and the other has a hex at both ends. They both function the same as described in the next step.

2. You can take the slack out of the cable by holding the Hex Flat Section/s of the In-Line Adjuster and rotating the body of the In-Line Adjuster in the clockwise direction as you look down on the cable. If the Cable is too tight, you can loosen it by rotating the adjuster in the opposite direction.
3. If the In-Line Adjuster Cable is adjusted all the way out and more adjustment is needed, the Belt needs to be replaced.



## Adjusting the Transmission Belt Tension through the Drive Control Cable

The Drive Belt will stretch a little when new, then more over time. If the Trimmer does not move forward with the Wheel engagement Bar engaged, adjust the Trimmer Drive Cable to put more tension on it. The Adjustment Jam Nuts are located at the upper end of the Drive Cable itself.

1. Locate the end of the Drive Cable along the right Handlebar. There are Jam Nuts threaded onto the Cable Threads.
2. Adjust the Jam Nuts towards the end of the Cable to tighten the Belt tension or towards the sheathing of the Cable to loosen the tension of the Belt (**Figure 45**).

**Note:** The Drive Cable should be adjusted so the Bar will pull close to the Handlebar but not completely against it without feeling extreme tension.

## Battery Care (Electric-Start Models)

Proper care can extend the life of a battery. Follow these recommendations to ensure best performance and long life:

- Before charging the Battery, observe its external appearance and keep it clean and dry. Never charge or use a Battery that shows cracks, changes shape, leaks, or is otherwise obviously damaged.
- **Do not allow the Battery to run down completely before charging. Leaving the Battery discharged damages the Battery.** If the machine is not used, charge the Battery every 4 to 6 weeks.
- Store an unused Battery in a dry environment with temperatures between +40°F (5°C) and +95°F (+35°C). Make sure the storage temperatures will never be outside of these limits. The lower the storage temperature is within the specified temperature, the better as the battery will discharge more slowly at lower temperatures.
- Do not charge an already charged Battery. In theory, you cannot overcharge our Battery with a trickle charger; however, when a Battery is fully charged and the charger is still on, it generates heat that could be harmful to the Battery. A fully charged Battery will read 13V-13.8V with a voltmeter.
- Do not continue to crank the Engine when the Battery charge is low.
- If the Battery begins to leak, avoid contact with the leaking acid. Place the damaged Battery in a plastic bag, then dispose of it properly.

## **! WARNING**

If battery acid does contact your skin or eyes, flush with cool water for at least 15 minutes and call a physician. If you ingest acid, call a physician immediately.

## Charging the Battery

### 6.75 and 7.25 EXI Electric Start Models

**Note:** The Electric Start EXI Engines are not equipped with Alternators. Running the Trimmer Engine will NOT Charge the Battery. Charge your Battery after every use by following the instructions below.

- Charging times will vary based on the Battery Charge Level. The Battery on your Trimmer/Mower may need charging for as long as 4 Hours. Never leave the Charger on the Battery for longer than 24 Hrs.
  - You can charge the Battery many times. The Battery lasts longer if you charge it before it is fully drained. Keep it fully charged and at room temperature when not using your DR TRIMMER/MOWER.
  - A fully Charged Battery should read 13V – 13.8V with a Voltmeter.
1. Remove the Rubber Cap from the Charger Fitting located near the Key Switch (**Figure 46**).

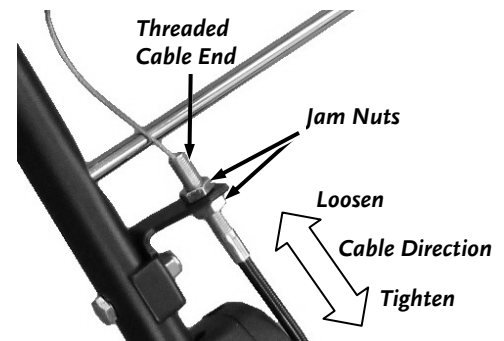

Figure 45

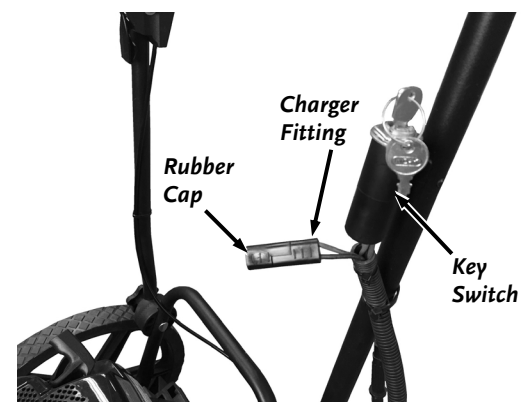

Figure 46

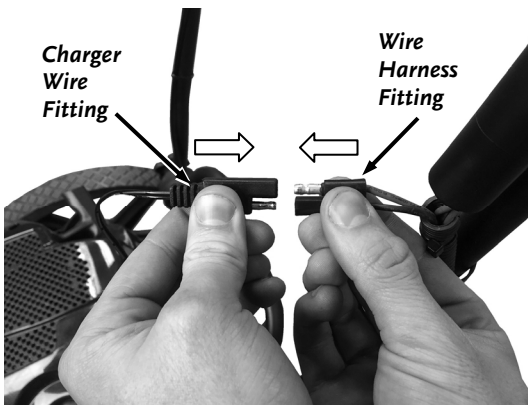

Figure 47

2. Line up the Fitting from the Charger Wire with the Fitting from the Trimmer Wire Harness and connect the Fittings together (**Figure 47**).
3. Plug the Charger into a standard 120V outlet. A Fully Drained Battery may take up to 4 hours to recharge. Do not leave the Charger on the Battery for longer than 24 Hrs.

### NOTICE

When you are finished charging the Battery, first disconnect the Charger from the Outlet, then disconnect the Battery Charger Wires from the Battery. If the Battery Charger Wires are left connected to the Battery, the Battery will discharge itself back into the Charger.

4. Reinstall the Rubber Cap to the Charger Fitting on the Trimmer Wire Harness.

### 8.75 Electric Start Models

Operate the Trimmer Engine for at least 45 minutes to maintain proper Battery charge. If the Battery loses its charge, you will need to charge it. We recommend using the DR Battery Charger (available for purchase) to recharge it. However, you may use a trickle Charger with an output of 14.4-15 volts at no more than 0.69 amps.

- Charging times will vary based on the charger used and the battery Level. At 0.69 amps, the Battery on your Trimmer/Mower may need charging for as long as 4 Hours.

**Note:** Using the recoil starter and then running the Engine will not recharge a dead or significantly discharged Battery.

To connect a Battery Charger to your DR TRIMMER/MOWER, follow the steps listed below.

1. Detach the two Battery wires going to the Battery on your DR TRIMMER/ MOWER.
  2. Attach the Black (-) alligator clipped wire from the Charger Adapter to the Negative (-) terminal of the Battery, then attach the Red (+) alligator clipped wire to the Positive (+) Battery terminal.
  3. Plug the Charger into a standard wall outlet.
- Typically, the Battery takes between 3 and 4 hours to fully charge. Do not leave the charger on the battery longer than 24 hours.
  - You can charge the Battery many times. The Battery lasts longer if you charge it before it is fully drained. Keep it fully charged and at room temperature when not using your DR TRIMMER/MOWER.
  - If the Battery does not hold its charge for very long under normal conditions or it simply won't hold a charge, then replace it. You can purchase replacement Batteries directly from us.

### NOTICE

When you are finished charging the battery, disconnect the charger from the outlet first, then disconnect the battery charger wires from the battery. If you leave the battery charger wires connected to the battery, the battery will discharge itself back into the charger.

### Disposing of the Battery Responsibly

The Battery is a sealed lead-acid Battery. Recycle or dispose of it in an environmentally sound way.

- Do not dispose of a lead-acid Battery in a fire; the Battery may explode or leak.
- Do not dispose of a lead-acid Battery in your regular, household trash. Law in most areas prohibits incinerating, disposing in a landfill, or mixing a sealed lead-acid Battery with household trash.

## ***Recycling a Used Battery***

Please dispose of your used Batteries responsibly by recycling them. Call your local Solid Waste Management District or your

---

### **NOTICE**

Please dispose of used batteries responsibly, according to your local hazardous materials regulations. Never throw away used batteries in your household trash.

---

local waste handler to locate the collection site nearest you. Some collection sites recycle Batteries year-round; others collect them periodically.

You can also visit the Web site of Earth 911 for more information [[www.earth911.com](http://www.earth911.com)]. Once there, click the “Find a Recycling Center” button and type “Waste Lead-acid Batteries - Non-automotive” in the “search for” box, and enter your zip code in the “Near” box. The site will show a list of recycling centers located near you.

For a fee, you can recycle your Batteries with the International Metals Reclamation Company. Visit them at [www.inmetco.com](http://www.inmetco.com) and click “Services” and then “Battery Recycling”; or contact them at One INMETCO Drive Ellwood City, PA 16117; Office (724) 758-2800; Fax (724) 758-2845; [sales@inmetco.com](mailto:sales@inmetco.com)

To learn more about hazardous waste recycling, visit the Web site for Battery Council International [[www.batterycouncil.org](http://www.batterycouncil.org)] or for the Environmental Protection Agency [[www.epa.gov](http://www.epa.gov)].

## Chapter 5: Troubleshooting

Most problems are easy to fix. Consult the Troubleshooting Table below for common problems and their solutions. If you continue to experience problems, contact us at [www.DRpower.com](http://www.DRpower.com) or call toll-free 1-800-DR-OWNER (376-9637) for support.

### **WARNING**

Before performing any maintenance procedure or inspection, stop the engine, wait five (5) minutes to allow all parts to cool. Disconnect the spark plug wire, keeping it away from the spark plug.

### Troubleshooting Table

SYMPTOM	POSSIBLE CAUSE
<i>Recoil will not pull out or is difficult to pull.</i>	<ul style="list-style-type: none"> <li>⇒ Check the Engine oil level, the Engine may be seized.</li> <li>⇒ There may be an oil compression lock in the Cylinder. Take out the Spark Plug; hold a rag over the Spark Plug hole and pull the Recoil Cord several times to blow out any oil in the Cylinder. Wipe off the Spark Plug and reinstall it.</li> <li>⇒ The Recoil may be broken or jammed. Try to turn the Engine pulley by hand, with the Spark Plug wire removed. If it turns, the Recoil is broken or jammed. Visit our web site at <a href="http://www.DRPower.com">www.DRPower.com</a> or call 1-800-DR-OWNER (376-9637) for assistance.</li> </ul>
<p><i>The Engine will not start manually.</i></p> <p><i>(Please refer to the Engine Owner's Manual for Engine-specific procedures.)</i></p>	<ul style="list-style-type: none"> <li>⇒ Check that the Throttle is in the most forward position (or RUN position when the engine is warm). Check the Throttle Cable and make sure that it is attached to the Engine and is moving freely.</li> <li>⇒ Check for proper attachment of the Spark Plug wire.</li> <li>⇒ Check that the Engine has the right amount of clean oil. If the oil is dirty, change it following the procedure on page 23.</li> <li>⇒ You should be using fresh, clean, unleaded gas with no more than 10% Ethanol. If the gas is old, change it. Use a fuel stabilizer if you keep gas longer than one month.</li> <li>⇒ Check the Fuel Filter (if equipped) to see if it is clear. Place a can under the Fuel Filter and remove the Fuel Line from the Engine side of the Filter. If gas flows freely, it is OK.</li> <li>⇒ Check that the Air Filter is clean. If it is dirty, change it following the procedure in the Engine Owner's Manual.</li> <li>⇒ Make sure that the Spark Plug is clean. If the Spark Plug is dirty or cracked, change it. If it's oily, leave it out, hold a rag over the Spark Plug hole and pull the Recoil Cord several times to blow out any oil in the Cylinder, then wipe off the Spark Plug and reinsert it.</li> <li>⇒ If the Engine still will not start, visit our web site at <a href="http://www.DRPower.com">www.DRPower.com</a> or call 1-800-DR-OWNER (376-9637) for assistance.</li> </ul>
<i>Engine smokes.</i>	<ul style="list-style-type: none"> <li>⇒ Check the oil level and adjust as needed.</li> <li>⇒ You may be operating the machine on too great an incline. (See Slopes on page 16)</li> <li>⇒ Check the Air Filter and clean or replace if needed.</li> <li>⇒ You may be using the wrong oil - too light for the temperature. Refer to your Engine Owner's Manual for detailed information.</li> <li>⇒ Clean the Engine cooling fins and the carburetor housing if they are dirty.</li> <li>⇒ If the Engine still smokes, visit our web site at <a href="http://www.DRPower.com">www.DRPower.com</a> or call 1-800-DR-OWNER (376-9637) for assistance.</li> </ul>

## Troubleshooting Table (Continued)

SYMPTOM	POSSIBLE CAUSE
<p><i>The Engine won't start using Electric-Start.</i></p> <p><i>(Please refer to the Engine Owner's manual for Engine-specific procedures.)</i></p>	<ul style="list-style-type: none"> <li>⇒ Check all of the items under the section called Electric Starting on page 12 and the previous section on Manual Starting.</li> <li>⇒ Check the wire connections - especially the ground connection, the large black wire coming from the Battery, where it connects to the Engine.</li> <li>⇒ Make sure the Battery is charged. Check the voltage yourself or at a service station. If it is low, charge it with a 12-volt, 1 to 2 Amp trickle charger. If you do not use your machine for at least 45 minutes at a time, the Battery may need to be periodically charged. See the Battery Care section on page 25.</li> <li>⇒ If your Battery is charged and your DR TRIMMER/MOWER still won't start, visit our web site at <a href="http://www.DRPower.com">www.DRPower.com</a> or call 1-800-DR-OWNER (376-9637) for assistance.</li> </ul>
<p><i>The Engine lacks power or is not running smoothly.</i></p> <p><i>(Please refer to the Engine Owner's Manual for Engine-specific procedures.)</i></p>	<ul style="list-style-type: none"> <li>⇒ Check the Throttle travel. The Throttle Lever should be in the most forward position (RUN position) when the engine is warm.</li> <li>⇒ Check for debris (hay seed, etc.) clogging the Air Filter Intake and clean out as required.</li> <li>⇒ The Engine's Blower Housing, Throttle Linkage, and Cooling Fins should be free of debris. Clean them following the instructions in the Engine Owner's Manual.</li> <li>⇒ Check that the Air Filter is clean. If it is dirty, change it following the procedure in the Engine Owner's Manual.</li> <li>⇒ Remove the Spark Plug wire and dry the connection with a rag.</li> <li>⇒ The Spark Plug may be dirty or cracked, change it. If it's oily, leave it out, hold a rag over the Spark Plug hole and pull the Recoil Cord several times to blow out any oil in the Cylinder, then wipe off the Spark Plug and reinsert it.</li> <li>⇒ You should be using fresh, clean, unleaded gas with no more than 10% Ethanol. If it is old, change it. Use a fuel stabilizer if you keep gas longer than one month.</li> <li>⇒ Check that the Engine has the right amount of clean oil. If it is dirty, change it following the procedure on page 23.</li> <li>⇒ If your Engine still lacks power, visit our web site at <a href="http://www.DRPower.com">www.DRPower.com</a> or call 1-800-DR-OWNER (376-9637) for assistance.</li> </ul>
<p><i>The Trimmer Head won't spin or lacks power.</i></p>	<ul style="list-style-type: none"> <li>⇒ Check for proper alignment of the V-Belt Idler assembly. Check it against Figure 28 in the "Replacing the Belt" section on page 19.</li> <li>⇒ The Belt may be worn or frayed; if so, replace it.</li> <li>⇒ If the Trimmer Head still will not spin, follow the procedure for "Adjusting the Trimmer Head Belt Tension through the Trimmer Control Cable" on page 24.</li> <li>⇒ If none of the above helps, visit our web site at <a href="http://www.DRPower.com">www.DRPower.com</a> or call 1-800-DR-OWNER (376-9637) for assistance.</li> </ul>
<p><i>The Trimmer Head keeps spinning or spins when you release the Engage Bar.</i></p>	<ul style="list-style-type: none"> <li>⇒ Check for proper alignment of the V-Belt Idler assembly. Check it against Figure 28 in the "Replacing the Belt" section on page 19.</li> <li>⇒ If you just installed a new belt, make sure you run it in by engaging the head at least 10 times.</li> <li>⇒ If the Trimmer Head keeps spinning when you release the Engage Bar, see "Adjusting the Trimmer Head Belt Tension through the Trimmer Control Cable" on page 24.</li> <li>⇒ If none of the above helps, visit our web site at <a href="http://www.DRPower.com">www.DRPower.com</a> or call 1-800-DR-OWNER (376-9637) for assistance.</li> </ul>

## Troubleshooting Table (Continued)

SYMPTOM	POSSIBLE CAUSE
<i>The cutting Cords are difficult to install.</i>	<ul style="list-style-type: none"> <li>⇒ The Cords may be dry. Soak them in a bucket of water for a few days before installing.</li> <li>⇒ The ends are too flat. Trim the ends of the Cord at an angle</li> </ul>
<i>The cutting Cords are breaking.</i>	<ul style="list-style-type: none"> <li>⇒ The Cords may be too dry. Store Cords in a plastic bag with a damp sponge or cloth to make them less prone to breaking or soak them in a bucket of water for a few days.</li> <li>⇒ You may be trying to do too much too fast. Ease into the material you are cutting; let the Cord tips do the work. Take small bites of tall or tough vegetation. Cut half a swath at a time, keeping the cut area to the discharge or right side of the Trimmer. Go over tall material twice, the first time with the Trimmer Head tilted up and back; the second time with the Mow-Ball® on the ground.</li> <li>⇒ Make sure that you are not hitting the Cords against a stone or a chain-link fence. The Cords won't last as long against obstacles as in the open. Work on controlling the cutting pattern. With practice, you'll learn to cut closer to obstacles without hitting them.</li> <li>⇒ If none of the above helps, visit our web site at <a href="http://www.DRPower.com">www.DRPower.com</a> or call 1-800-DR-OWNER (376-9637) for assistance.</li> </ul>
<i>The cutting Cords are pulling out.</i>	<ul style="list-style-type: none"> <li>⇒ You may be moving too fast into tough, woody growth. In doing so, the Cords may wrap on stalks and pull out. Check the operating tips in the section above on breaking Cords.</li> <li>⇒ Make sure that you are not trying to cut material too heavy for the Cord. The design of your Trimmer is to cut green material up to about the thickness of a pencil.</li> <li>⇒ If none of the above helps, visit our web site at <a href="http://www.DRPower.com">www.DRPower.com</a> or call 1-800-DR-OWNER (376-9637) for assistance.</li> </ul>
<i>The Mow-Ball® is wearing too quickly.</i>	<ul style="list-style-type: none"> <li>⇒ You may be pushing the Trimmer Head down into the ground. The DR TRIMMER/MOWER works best with a light touch, with the Mow-Ball® resting easily on the ground or slightly raised.</li> <li>⇒ You may be hitting the Mow-Ball® against rocks, concrete driveways or other hard obstacles. Try approaching them slowly, and from different directions, to avoid unnecessary wear.</li> <li>⇒ If none of the above helps, visit our web site at <a href="http://www.DRPower.com">www.DRPower.com</a> or call 1-800-DR-OWNER (376-9637) for assistance.</li> </ul>
<i>The Drive Wheels don't turn when backing up (Self Propelled model).</i>	<ul style="list-style-type: none"> <li>⇒ To release the clutches in the Transmission you must push the Trimmer forward a little before pulling back.</li> <li>⇒ The belt may be stretched so much it does not pull against the Transmission in the disengaged position. Replace the belt.</li> </ul>
<i>Self Propelled Wheel Drive is not functioning properly</i>	<ul style="list-style-type: none"> <li>⇒ The Drive Cable may be out of adjustment. Check the Wheel Engage Bar tension and adjust the cable if necessary. See procedures on page 24.</li> <li>⇒ The Drive Belt may be worn or frayed. If so replace it.</li> </ul>

**Notes:**

## Chapter 6: Parts Lists and Schematic Diagrams

### Parts List – Main Frame Assembly

**Note:** Part numbers listed are available through DR Power Equipment.

Ref#	Part#	Description	Ref#	Part#	Description
1	31130	Frame W/ Labels, TR4	25	14375	Washer, .505" ID X 1" OD
2	36979	Kit, Engine, B&S, 6.75 EXi, M/S	26	11076	Nut, Nylon Lock, 5/16-18, ZP
	36980	Engine w/Labels, B&S, 6.75, E/S	27	27660	Pin, Belt Guide
	36981	Kit, Engine, B&S, 7.25 EXi, M/S	28	11239	Washer, Flat, 3/8" USS
	34355	Engine w/Labels, B&S, 7.25, E/S	29	31096	Spindle, TR4
	A0000023103	Engine w/Labels, B&S, 8.75, M/S	30	31131	Guard W/ Labels, TR4
	A0000023104	Engine w/Labels, B&S, 8.75, E/S	31	31099	Spacer, .680" X .984" X .310", ZP
3	37589	Screw, TF, Taptite 3/8-16 X 1-1/4"	32	31098	Can, Anti-Wrap
4	18081	Washer, Lock, 3/8", Split	33	34454	Plate, Line Spacer, D Bore
5	31105	Guard, Debris	34	31101	Mow Ball, Hex Recess
6	31117	Screw, HWH, 1/4-20 X .75", ZP	35	31301	Bolt, HCS, 3/8-16 X 1", GR5, ZP, High HD
7	11238	Washer, Flat, 1/4" USS	36	31296	Bracket, Battery (E/S Only)
8	31087	Pulley, Drive, 3L V-Belt, 7/8" Shaft	37	14386	Pad, Battery, 1.38" X 7.0" (E/S Only)
	32157	Pulley, Drive, Double, 7/8 Shaft (SP Only)	38	24749	Battery, 2.3Ah, 12V (E/S Only)
9	11155	Bolt, HCS, 3/8-24 X 3/4", ZP	39	14385	Clamp, Battery (E/S Only)
10	31088	Belt, V, 3L, Gates 6744	40	36559	Guide, Belt, Engine (Non Self Propelled Only)
11	31094	Pulley, Drive, 3L V-Belt, .67" Shaft		38905	Guide, Belt, Engine (Self Propelled Only)
12	11914	Key, Square, 3/16" X 3/4"			
13	12697	Washer, Fender, 1/4" X 1", ZP			
14	18013	Bolt, Tri, 1/4-20 X 1" (E/S Only)			
15	32160	Bracket, Cable, Self Propel (SP Only)			
16	31089	Bracket, Idler			
17	31092	Pulley, Idler, 3L V-Belt, 2.0" OD			
18	31093	Pulley, Idler, Flat, 1.99" OD			
19	31091	Spacer, .385" X .62" X .219", ZP			
20	31281	Strap, Belt Retainer			
21	11075	Nut, Nylon Lock, 3/8-16, ZP			
22	31090	Spring, E, .30" OD, .035" Wire, 3.0" L			
23	12336	Bolt, HCS, 5/16-18 X 1-1/4", GR5, ZP			
24	14360	Standoff, Clutch Arm			

#### Not shown on Illustration:

31102	Cord Pack, 25", 12 Piece
19202	Label, DR Logo, 4" Round
13649	Label, Danger
13758	Label, Check Oil
14823	Label, Safety Icons
37829	Label, Belt Routing
37853	Charger, Battery, TR4 (E/S, B&S EXI Models only)
24064	Label, Trimmer Patent #
24139	Label, DR logo, 4", 4 color



# Schematic – Main Frame Assembly

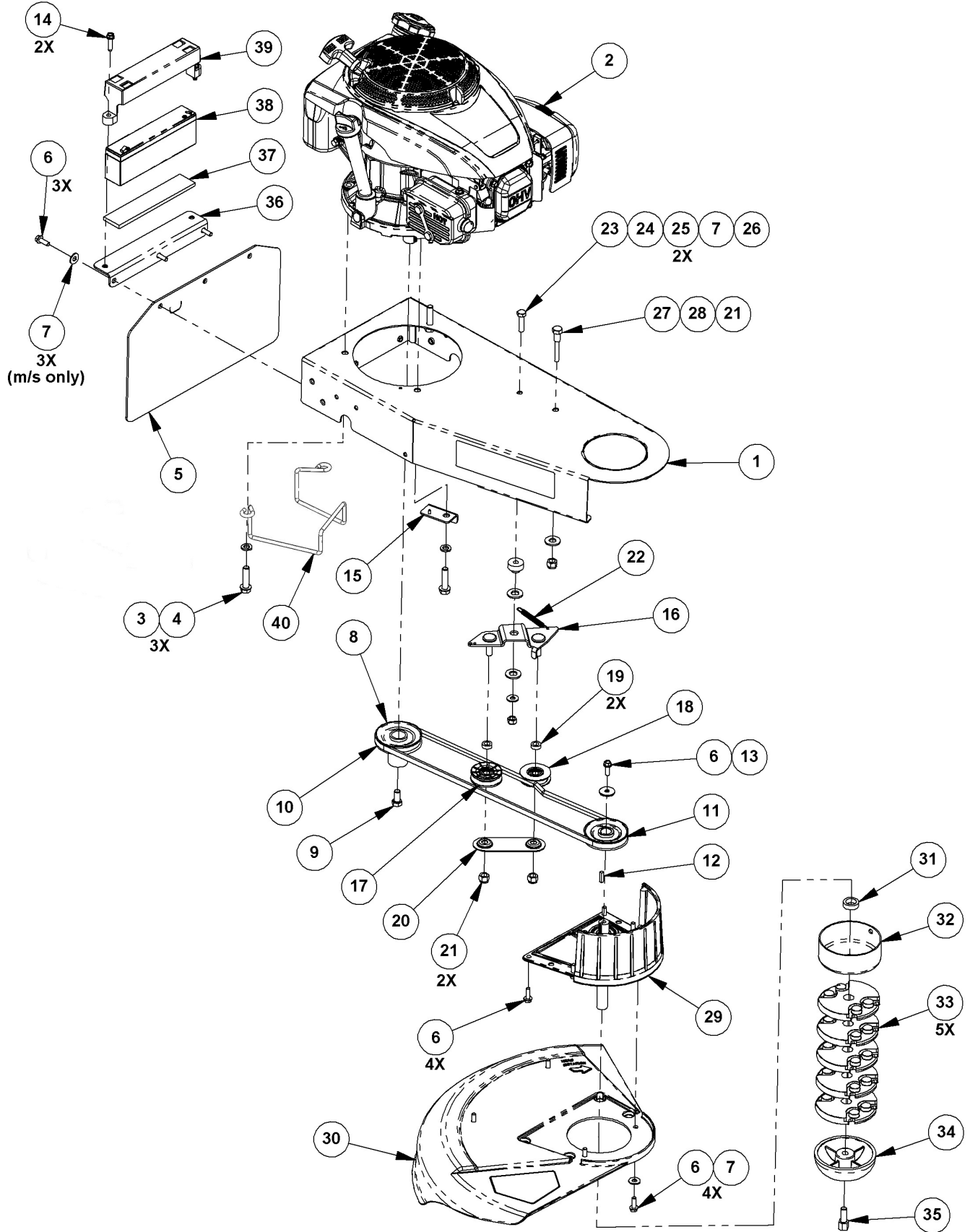

## Parts List – Handlebar and Axle Assembly (Non Self Propelled Model)

**Note:** Part numbers listed are available through DR Power Equipment.

<u>Ref#</u>	<u>Part#</u>	<u>Description</u>	<u>Ref#</u>	<u>Part#</u>	<u>Description</u>
1	31107	Axle, Welded	13	31112	Knob, 2.25" Dia, 5/16-18 Insert
2	31117	Screw, HWH, 1/4-20 X .75", Taptite	14	31114	Cable, PTO, Snap-On
3	31108	Wheel, 14", 5 Spoke (Premier Only)		31297	Cable, PTO, Snap-On, Switch Mount (E/S Only)
	31290	Wheel, 16", 5 Spoke		11308	Switch, W/ Key & Hardware, 2 Pos (E/S Only)
4	15233	Nut, Nylon Lock, 7/16-20, LP	15	11308	Switch, W/ Key & Hardware, 2 Pos (E/S Only)
5	37178	Handlebar, Upper (Premier Only)	16	31299	Wire Harness, TR4, B&S (8.75 E/S Only)
	31287	Handlebar W/Grip, Upper, Ergonomic		37801	Wire Harness, TR4, B&S, EXI (6.75 + 7.25 E/S Only)
6	31110	Handlebar, Lower	17	14397	Cable, Throttle
7	37179	Bail Bar, Straight (Premier Only)	18	11456	Bolt, HCS, 1/4-20 X 2", GR2, ZP
	31288	Bail Bar, Ergonomic	19	11238	Washer, Flat, 1/4" USS
8	19135	Adjuster, Handlebar, Inside	20	11073	Nut, Nylon Lock, 1/4-20, ZP
9	14373	Adjuster, Handlebar, Outside	21	11214	Cable Tie, 7-1/2" L
10	14393	Spring, C, .720" OD, .063" Wire, .63", ZP			
11	14464	Bolt, C-Head, 5/16-18 X 3"			
12	31116	Screw, HWH, 5/16-18 X .75", Taptite			

**Schematic – Handlebar and Axle Assembly (Non Self Propelled Model)**

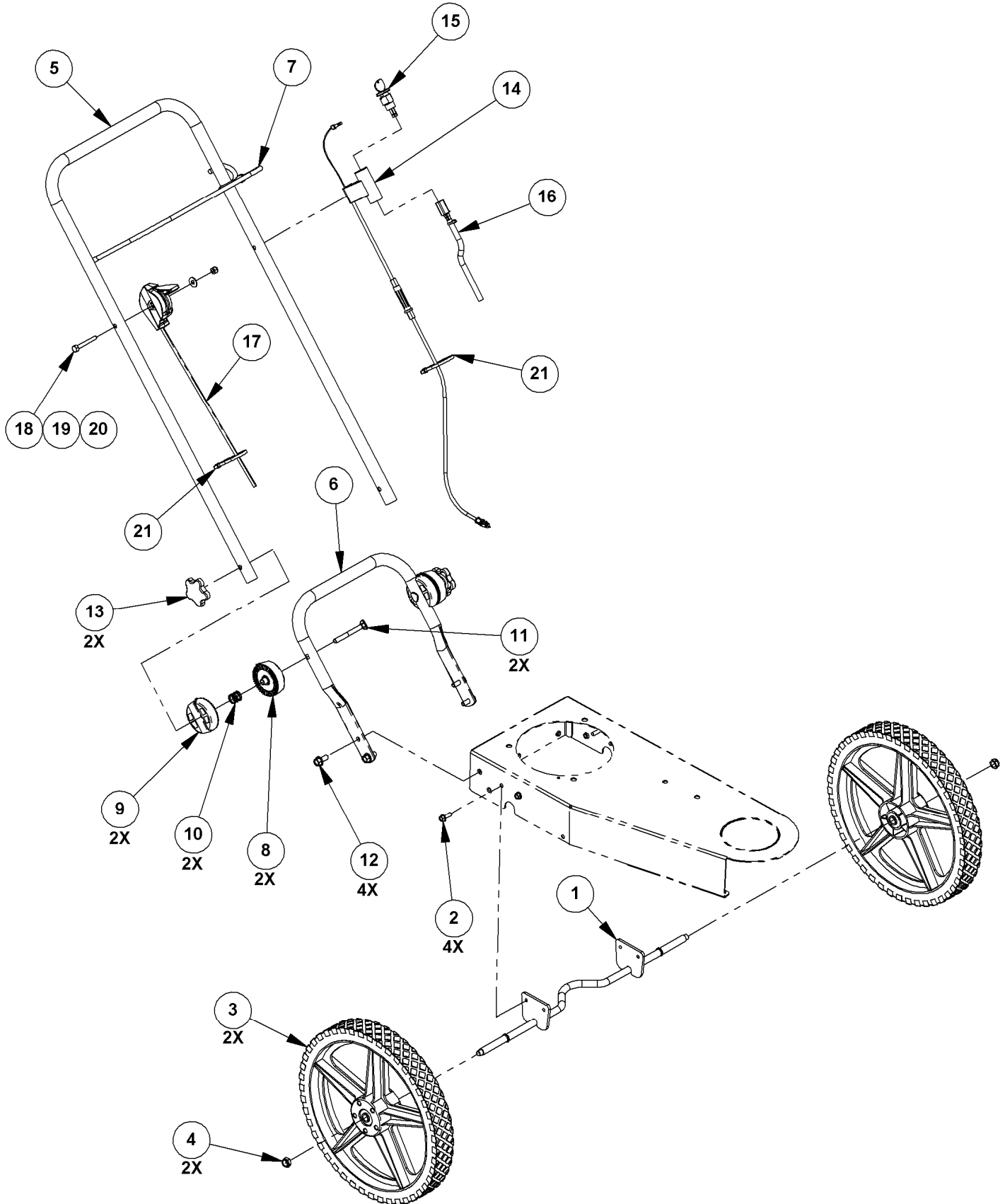

## Parts List – Handlebar and Axle Assembly (Self Propelled Model)

**Note:** Part numbers listed are available through DR Power Equipment.

<u>Ref#</u>	<u>Part#</u>	<u>Description</u>	<u>Ref#</u>	<u>Part#</u>	<u>Description</u>
1	32339	Drivetrain	17	32169	Bail Bar, Ergonomic, LH Half
2	31117	Screw, HWH, 1/4-20 X .75", Taptite	18	32521	Bail Bar W/ Label, Self Propel
3	32337	Cover, Bottom, Self Propel	19	32161	Cable, Self Propel
4	11238	Washer, Flat, 1/4", USS	20	14368	Bracket, Cable
5	32171	Wheel, 14", 5 Spoke, D Bore	21	10145	Bolt, HCSs, 1/4-20 X 1-1/2", GR2, ZP
6	32338	Washer, Flat, .510" X .875" X .1", ZP	22	11073	Nut, Nylon Lock, 1/4-20, ZP
7	16413	Nut, Nylon Lock, 3/8-16, LP	23	14397	Cable, Throttle
8	11239	Washer, Flat, 3/8" USS	24	11456	Bolt, HCS, 1/4-20 X 2", GR2, ZP
9	31287	Handlebar W/Grip, Upper, Ergonomic	25	31297	Cable, PTO, Snap-On, Switch Mount
10	31110	Handlebar, Lower	26	11308	Switch, W/ Key & Hardware, 2 Pos
11	19135	Adjuster, Handlebar, Inside	27	31299	Wire Harness, TR4, B&S (E/S Only)
12	14373	Adjuster, Handlebar, Outside	28	11214	Cable Tie, 7-1/2" L
13	14393	Spring, C, .720" Od, .063" Wire, .63", ZP	29	36558	Guide, Drive Belt, Self Propel
14	14464	Bolt, C-Head, 5/16-18 X 3"	30	31283	Nut, Lock, 1/4-20, Serrated Flange
15	31112	Knob, 2.25" Dia, 5/16-18 Insert	31	11238	Washer, Flat, 1/4", USS
16	31116	Screw, HWH, 5/16-18 X .75", Taptite			

# Schematic – Handlebar and Axle Assembly (Self Propelled Model)

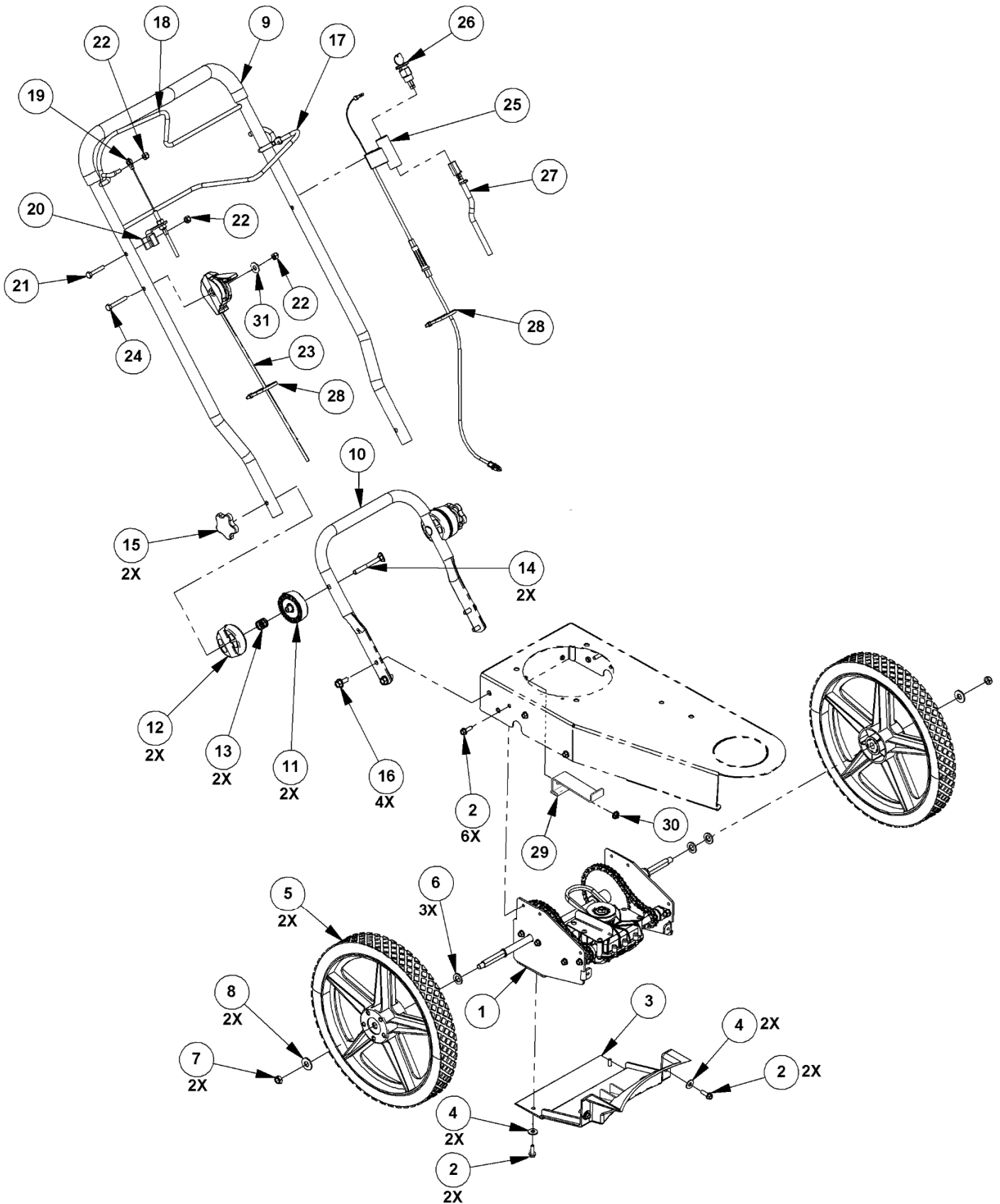

## Parts List – Drive train Assembly (Self Propelled Model)

**Note:** Part numbers listed are available through DR Power Equipment.

<u>Ref#</u>	<u>Part#</u>	<u>Description</u>	<u>Ref#</u>	<u>Part#</u>	<u>Description</u>
1	32162	Support, Drive, Self Propel	11	32341	Collar, Shaft, 1/2", Clamp-On
2	32167	Bearing Sleeve, 1/2" X 3/4" X 3/4"	12	32168	Chain, #35, 51 Link & Master
3	32164	Axle, LH, Self Propel	13	31117	Screw, HWH, 1/4-20 X 3/4", Taptite
4	18975	Retaining Ring, .468" I.D.	14	11073	Nut, Nylon Lock, 1/4-20, ZP
5	21318	Key, Woodruff, 1/8" X 1/2"	15	31313	Transmission, 10.5:1
6	32166	Sprocket, #35, 40 Tooth, 2 Hub	16	31100	Belt, V, 31 X 13, Wrapped
7	32338	Washer, Flat, .510" X .875" X .10", ZP	17	32159	Bracket, Transmission, Cable
8	32163	Axle, RH, Self Propel	18	32158	Bracket, Transmission
9	32165	Sprocket, #35, 40 Tooth, 1/2" Bore	19	32342	Screw, 10-14 X 5/8", Plastite, 48-2
10	17955	Bearing W/Flange	20	19381	Sprocket, No.35, 10 Tooth
			21	33560	Shim, .516 ID x .99 OD x .05

# Schematic – Drive train Assembly (Self Propelled Model)

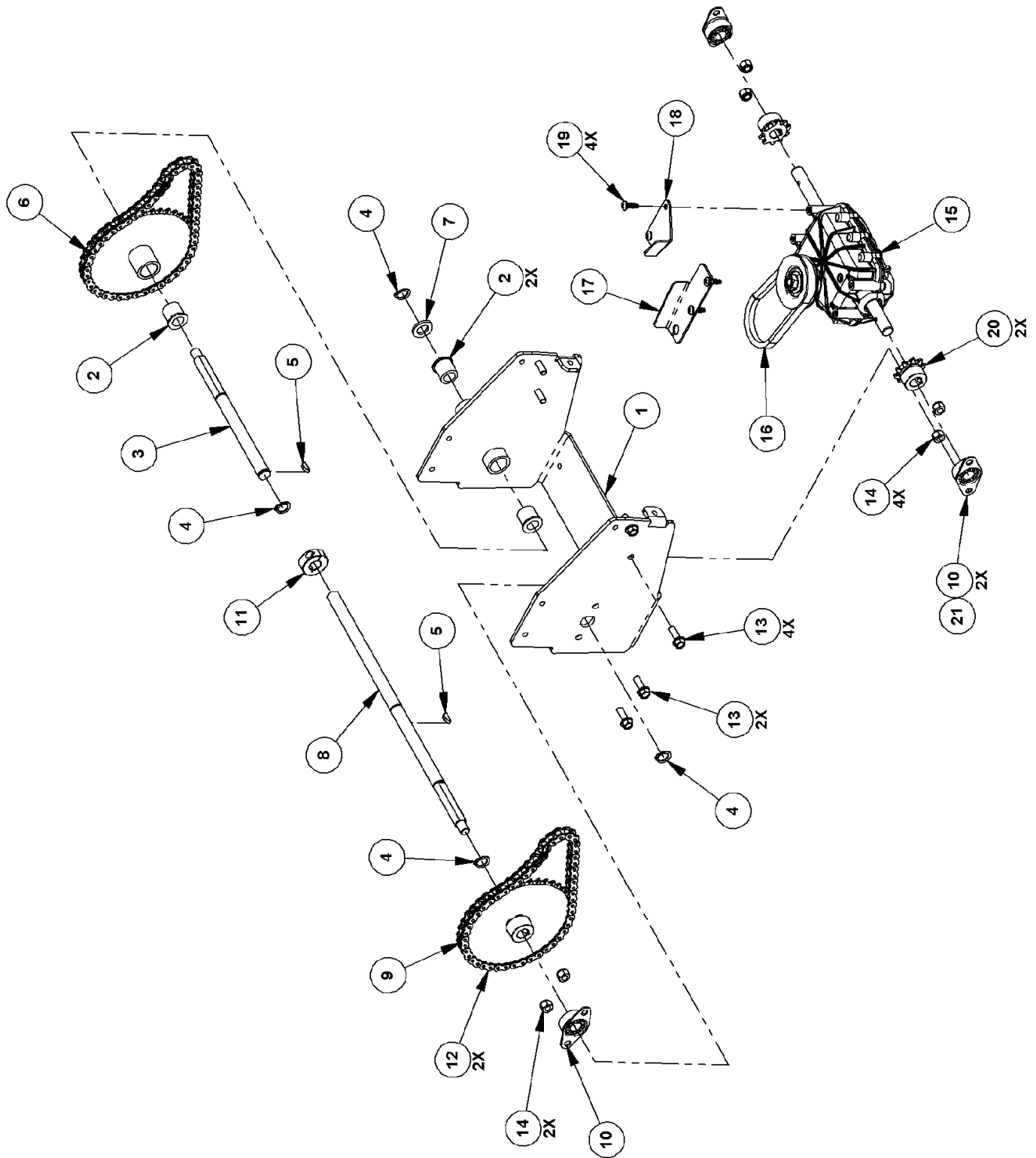

## Daily Checklist for the DR TRIMMER/MOWER

To help maintain your DR TRIMMER/MOWER for optimum performance, we recommend you follow this checklist each time you use your machine.

### WARNING

Before performing any maintenance procedure or inspection, stop the engine, wait five (5) minutes to allow all parts to cool. Disconnect the spark plug wire, keeping it away from the spark plug.

- [ ] OIL: With the machine on a level surface, check the Engine oil level with the Dipstick and add more if necessary (only add oil to the level indicated on the Dipstick - do not overfill). Use SAE 30 high detergent motor oil.
- [ ] GAS: Fill the Fuel Tank with clean, fresh, unleaded gasoline with no more than 10% Ethanol.
- [ ] ENGINE AIR COOLING SYSTEM: It is very important to keep the Engine clean of debris. Remove grass and other built-up materials from the Air Intake Screen before, during, and after you mow. Regularly remove debris from the Blower Housing and Cooling Fins. A dirty Engine retains heat and can cause damage to the internal Engine parts.
- [ ] CUTTING CORDS: Replace broken or frayed Cords.
- [ ] MOW-BALL® and LINE PLATES: Check the Mow-Ball® and Line Plates for wear and replace as needed.
- [ ] GENERAL CONDITION: Check the general condition of the machine, e.g.; nuts, bolts, welds etc.

## End of Season and Storage

**NOTE:** Please refer to the Engine Owner's Manual for engine-specific procedures.

### WARNING

- Before performing any maintenance procedure or inspection, stop the engine, wait five (5) minutes to allow all parts to cool. Disconnect the spark plug wire, keeping it away from the spark plug.
- Never store the DR Trimmer/Mower with fuel in the fuel tank inside a building where ignition sources are present, such as hot water and space heaters, clothes dryers and the like. If you are going to drain the fuel tank, do this outdoors. Allow the engine to cool before storing in any enclosure.
- When not in use, your DR Trimmer/Mower should be stored out of the reach of children and in a dry location.

- Check the Belt for wear.
- Change the Engine oil. This will help to eliminate sludge and acids in the Engine.
- Remove the Spark Plug and pour about 1 ounce of motor oil into the cylinder hole. Reinstall the Plug and pull the Recoil Starter Rope until you feel strong resistance. This will coat the piston and seat the valves to prevent moisture buildup.
- Clean or replace the Engine Air Filter.
- Clean any dirt and debris from the cylinder head cooling fins, carburetor linkage, blower housing, debris screen, and muffler area of the Engine.
- Remove any wrapped weeds from the Mow-Ball®, Wheel Spokes, and Axle. Clean grass and debris from the top and underneath the Trimmer Frame.
- Check to make sure the operator controls are moving freely. Lubricate the Throttle.
- If your Engine has a Fuel Filter, replace it.
- If your DR TRIMMER/MOWER will be idle for more than 30 days, we recommend using a gas stabilizer. This will prevent sediment from gumming up the Carburetor. If there is dirt or moisture in the gas or Tank, remove it by draining the Tank. Completely fill the Tank with fresh, unleaded gas with no more than 10% Ethanol and add the appropriate amount of stabilizer or gasoline additive. Run the Engine for a short time to allow the additive to circulate.



75 MEIGS ROAD, P.O. BOX 25, VERGENNES, VERMONT 05491