

# DR<sup>®</sup> FIELD and BRUSH MOWER SAFETY & OPERATING INSTRUCTIONS



## Models:

PRO 26 (10.5HP)  
PRO 26 (14.5HP & 15.5HP)  
PRO XL30 (16.5HP & 17.5HP)  
PRO XL30 (20.0HP & 27HP)  
PRO MAX34 (20.0HP)

Serial No. \_\_\_\_\_

Order No. \_\_\_\_\_

DR Power Equipment  
Toll-free phone: 1-800-DR-OWNER (376-9637)  
Website: [www.DRpower.com](http://www.DRpower.com)

## **WARNING**

Read and understand this manual and all instructions before operating the DR FIELD and BRUSH MOWER.

# Table of Contents

Chapter 1: General Safety Rules..... 3

Chapter 2: Setting Up the DR FIELD and BRUSH MOWER ..... 7

Chapter 3: Operating the DR FIELD and BRUSH MOWER ..... 12

Chapter 4: Maintaining the DR FIELD and BRUSH MOWER..... 19

Chapter 5: Troubleshooting ..... 25

Chapter 6: Parts Lists and Schematic Diagrams ..... 27

## Conventions used in this manual

### **WARNING**

This indicates a hazardous situation, which, if not avoided, **could** result in death or serious injury.

### **CAUTION**

This indicates a hazardous situation, which, if not avoided, **could** result in minor or moderate injury.

### **NOTICE**

This information is important in the proper use of your machine. Failure to follow this instruction could result in damage to your machine or property.

## Serial Number and Order Number

A Serial Number is used to identify your machine and is located on the Serial Number Label on your machine (**Figure 1**). An Order Number is used to check and maintain your order history and is located on your packing slip. For your convenience and ready reference, enter the Serial Number and Order Number in the space provided on the front cover of this manual.

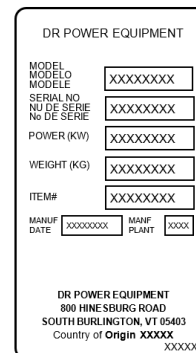

Figure 1

## Additional Information and Potential Changes

DR Power Equipment reserves the right to discontinue, change, and improve its products at any time without notice or obligation to the purchaser. The descriptions and specifications contained in this manual were in effect at printing. Equipment described within this manual may be optional. Some illustrations may not be applicable to your machine.

## California Proposition 65

 **WARNING**

**CANCER AND REPRODUCTIVE HARM - [www.P65Warnings.ca.gov](http://www.P65Warnings.ca.gov).**











## Chapter 1: General Safety Rules

### **WARNING**

Read this safety & operating instructions manual before you use the DR FIELD and BRUSH MOWER. Become familiar with the operation and service recommendations to ensure the best performance from your machine. If you have any questions or need assistance, please contact us at [www.DRpower.com](http://www.DRpower.com) or call toll-free 1-800-DR-OWNER (376-9637) and one of our Technical Support Representatives will be happy to help you.

### Labels

The DR FIELD and BRUSH MOWER carries prominent labels as reminders for its proper and safe use. Shown below are copies of all the Safety and Information labels that appear on the equipment. Take a moment to study them and make a note of their location on your mower as you set up and before you operate the unit. Replace damaged or missing safety and information labels immediately.













 1-800-DR-OWNER DRpower.com	<b>TO START ENGINE</b> 1. Shift WHEEL SPEED to NEUTRAL 2. Move THROTTLE to  3. Push PTO KNOB  4. Rotate KEY to  (Electric start) Rotate KEY to  (Manual Start) 5. Pull RECOIL on engine (Manual Start) 6. Move THROTTLE to 	<b>PTO OPERATION</b> 1. Depress OPERATOR PRESENCE LEVER (RED)  2. Pull PTO KNOB to engage  3. Push PTO KNOB to stop 	<b>WHEEL DRIVE</b> 1. Select desired WHEEL SPEED 2. Depress TRACTION DRIVE LEVER to drive. 3. Release TRACTION DRIVE LEVER to stop.	<b>TO SHUT OFF ENGINE</b> 1. Move THROTTLE to  2. Turn KEY to  <b>Note:</b> Releasing OPERATOR PRESENCE LEVER (RED) while PTO is engaged will shut off the engine.
	<b>For models with Power Steering:</b> Squeeze BRAKE LEVER to steer in corresponding direction. If wheel spins, squeeze corresponding BRAKE LEVER to slow spinning wheel. Power will be automatically applied to stationary wheel.			

#352761



### **WARNING**

#### AVOID SERIOUS INJURY OR DEATH

- Read and understand the operator's manual
- Remove objects that could be thrown by the blade
- Keep bystanders at least 100 feet from work area
- Always keep hands and feet clear of blade and other moving parts
- Keep safety devices in place and working

 1-800-DR-OWNER DRpower.com 	<b>TO START ENGINE</b> 1. Shift WHEEL SPEED to NEUTRAL 2. Move THROTTLE to  or Pull CHOKE KNOB (if equipped) 3. Push PTO KNOB  4. Rotate KEY to  (Electric start) Rotate KEY to  (Manual Start) 5. Pull RECOIL on engine (Manual Start) 6. Push CHOKE KNOB (if equipped) 7. Move THROTTLE to 	<b>PTO OPERATION</b> 1. Depress OPERATOR PRESENCE LEVER (RED)  2. Pull PTO KNOB to engage  3. Push PTO KNOB to stop 	<b>WHEEL DRIVE</b> 1. Select desired WHEEL SPEED 2. Depress TRACTION DRIVE LEVER to drive 3. Release TRACTION DRIVE LEVER to stop	<b>TO SHUT OFF ENGINE</b> 1. Move THROTTLE to  2. Turn KEY to  <b>Note:</b> Releasing OPERATOR PRESENCE LEVER (RED) while PTO is engaged will shut off the engine.
	<b>For models with Power Steering:</b> Squeeze BRAKE LEVER to steer in corresponding direction. If wheel spins, squeeze corresponding BRAKE LEVER to slow spinning wheel. Power will be automatically applied to stationary wheel.			

#A0006776178 (27HP)

 <b>WARNING!</b>	<b>AVOID SERIOUS INJURY OR DEATH</b>
	Read and understand the operator's manual.  <ul style="list-style-type: none"> <li>• Remove objects that could be thrown by the blade.</li> <li>• Keep bystanders at least 100 feet from work area.</li> <li>• Always keep hands and feet clear of blade and other moving parts.</li> <li>• Keep safety devices in place and working</li> </ul>

#363721



#136491



#136831



#137581

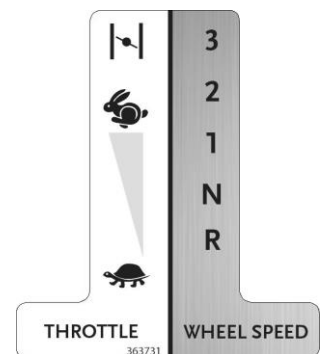

#363731

## **Warnings, Cautions, and Notices**

### **General Safety**

---

#### **WARNING**

Safe operation of the DR FIELD and BRUSH MOWER is necessary to prevent death or serious injury. Always take the following precautions when operating this machine:

- The DR FIELD and BRUSH MOWER is designed to mow grass and brush. Do not use it for any other purpose.
  - If the machine makes an unusual noise or vibration or if there are obstructions underneath the machine, shut off the DR FIELD and BRUSH MOWER engine. Wait five minutes for the engine to cool. Disconnect the spark plug wire(s) and then inspect the machine for clogs or loose parts. Clear any obstructions and repair and/or replace damaged parts.
  - The mower blades are sharp. Wrap the blades or wear gloves and use extra caution when servicing.
  - Always keep the machine in good, safe operating condition. Always make certain nuts and bolts are tight. Do not use substitute hardware.
  - See manufacturer's instructions for proper operation and installation of accessories. Only use accessories approved by DR Power Equipment.
-

## General Safety (Continued)

---

### **WARNING**

- Use the DR FIELD and BRUSH MOWER only in daylight or very well lit work areas.
  - Be sure all blade and wheel controls are disengaged before attempting to start the engine. Engage and disengage the blade a few times to get used to it before mowing.
  - Always give undivided attention to the machine and your surroundings. Watch for traffic when mowing near roadways.
  - Disengage the mower blades and exercise extreme caution when on or crossing drives, walks, or roads.
  - In an emergency, to quickly stop the cutting blade and shut off the engine, remove your hand from the operator presence lever on the left handlebar.
  - Always shut off the engine whenever you leave the machine.
  - When operating over uneven and/or slippery terrain, use extreme caution to ensure solid and firm footing. Keep a firm hold on the handlebars and walk, never run.
  - Do not operate the machine when under the influence of drugs, alcohol, or medication.
- 

## Protecting Yourself and Those around You

---

### **WARNING**

This is a high-powered machine with moving parts operating at high speeds. Always take the following precautions when operating this machine:

- Always wear protective goggles or safety glasses with side shields.
  - Wear sturdy shoes with non-slip treads.
  - Wear long pants while operating the mower.
  - Avoid wearing loose clothing or jewelry which can catch on moving parts
  - Use ear protectors or ear plugs.
  - We recommend wearing gloves while mowing. Be sure your gloves fit properly and do not have loose cuffs or drawstrings.
  - Allow only responsible adults who are familiar with these safety rules and operating instructions to use your DR FIELD and BRUSH MOWER.
  - Keep your hands and feet away from the blades, belt, pulley, and concealed areas while the engine is running.
  - Keep people and pets away from your machine and out of the work area at all times. Disengage the blade and stop the engine if a person or pet is within 100 feet of the machine.
  - Children are often attracted to the machine and the mowing activity. Never assume that children will remain where you last saw them.
  - Never allow people to ride on the mower.
  - Before mowing, clear the area of objects such as rocks, toys, wire, bones, sticks, etc.
  - Never remove or alter standard parts or add anything to the DR FIELD and BRUSH MOWER especially all shields and guards.
  - Before and while moving backwards, look behind, and down, for small children.
  - Use extra care when approaching blind corners, shrubs, trees, or other objects that may obscure your vision.
  - Use caution when mowing close to fences, buildings, and trees so as not to hit the handle bar. You could injure your hand or lose control of the machine.
- 

## Slope Operation

---

### **WARNING**

Slopes are a major factor related to slip and fall accidents. All slopes require caution. If you feel uneasy on a slope, do not mow it. Always take the following precautions when using this machine on slopes:

- Always mow across the face of slopes. Exercise extreme caution when changing direction on slopes.
  - Never operate near drop-offs, ditches, or embankments, or on slopes greater than 20 degrees
  - Never operate on wet or slippery slopes.
-

## ***Safety with Gasoline - Powered Machines***

### **! WARNING**

Gasoline is a highly flammable liquid that gives off flammable vapor that can be ignited and cause a fire or explosion. Always follow these precautions:

- Never run the engine in an enclosed area or without proper ventilation as the exhaust contains carbon monoxide, an odorless, tasteless, and poisonous gas.
- Store all fuel and oil in containers specifically designed and approved for this purpose. Keep away from heat and open flame and out of the reach of children.
- Replace rubber fuel lines and grommets when worn or damaged or after 5 years of use, whichever comes first.
- Fill the gasoline tank outdoors with the engine off and after the engine has cooled completely. Do not handle gasoline if you or anyone nearby is smoking.
- If you spill gasoline do not start the engine. Move the machine away from the area until the gas vapors have dissipated.
- Before performing engine maintenance or repairs; shut down the engine, disconnect the spark plug wire(s), and wait 5 minutes for the engine to cool.
- Never change the engine governor settings or modify the engine speed.
- Never check for an ignition spark with the spark plug or spark plug wire(s) removed. Always use an approved spark tester.
- Never tamper with safety devices. Regularly check their proper operation.
- Allow the engine to cool completely before storing in any enclosed area.
- Keep combustible substances away from the engine when it is hot. Never cover the machine while the muffler is still hot.
- To reduce fire hazard, keep the engine and muffler free of debris build-up.
- Do not operate the engine with the air cleaner or the carburetor air intake cover removed.
- Do not use flammable solutions to clean the air filter.
- Never operate the engine without the muffler and deflector, if so equipped. Inspect the muffler and deflector periodically and replace if necessary.
- The muffler and engine become very hot and can cause a severe burn. Do not touch.

### ***A Note to All Users***

Under California law, and the laws of some other states, you are not permitted to operate an internal combustion engine using hydrocarbon fuels without an engine spark arrester. This also applies to operation on US Forest Lands. All DR® FIELD and BRUSH MOWERS shipped to California, New Mexico and Washington State are provided with spark arresters. Failure of the owner or operator to maintain this equipment in compliance with state regulations is a misdemeanor under California law and may be in violation of other state and/or federal regulations. Contact your appropriate local or state organization for specific information in your area.

No list of warnings and cautions can be all-inclusive. If situations occur that are not covered by this manual, the operator must apply common sense and operate this DR FIELD and BRUSH MOWER in a safe manner. Contact us at [www.DRpower.com](http://www.DRpower.com) or call 1-800-DR-OWNER (376-9637) for assistance.

## Chapter 2: Setting Up the DR FIELD and BRUSH MOWER

It may be helpful to familiarize yourself with the controls and features of your DR FIELD and BRUSH MOWER as shown in **Figure 2** before beginning these procedures. If you have any questions at all, please feel free to contact us at [www.DRpower.com](http://www.DRpower.com).

### DR FIELD and BRUSH MOWER Controls and Features

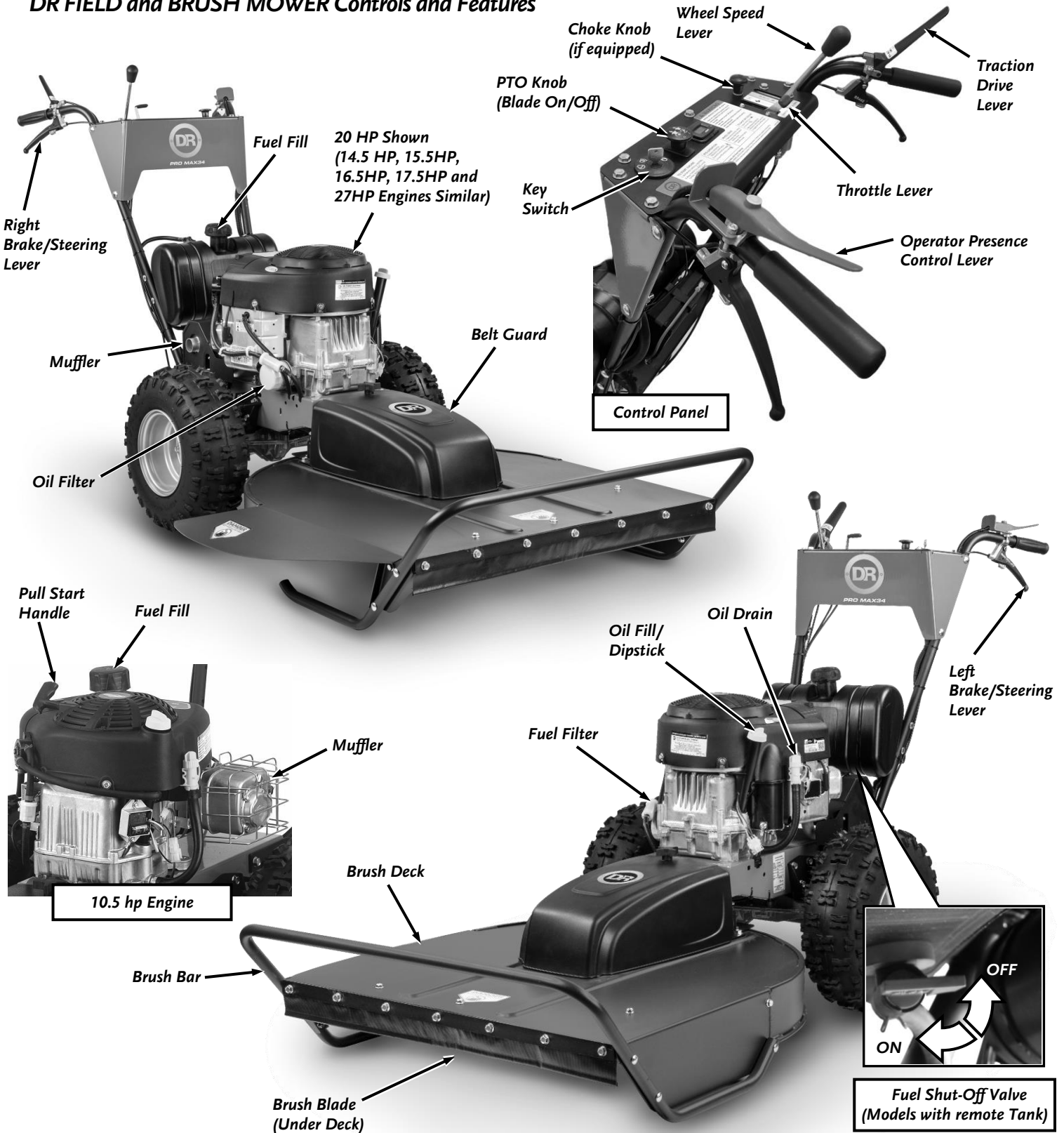

Figure 2

## Specifications

	10.5HP PRO 26	14.5HP & 15.5HP PRO 26	16.5HP & 17.5HP PRO XL30	20.0HP PRO XL30	20.0HP PRO MAX34	27.0HP PRO XL30
<b>Engine</b>	See Engine Owner's Manual	See Engine Owner's Manual	See Engine Owner's Manual	See Engine Owner's Manual	See Engine Owner's Manual	See Engine Owner's Manual
<b>Fuel Capacity</b>	3 Quarts	2 Gal. (7.57 L)	2 Gal. (7.57 L)	2 Gal. (7.57 L)	2 Gal. (7.57 L)	2 Gal. (7.57 L)
<b>Cutting Capacity</b>	4' Tall Grass 8' Tall Brush 2" Thick Saplings	4' Tall Grass 8' Tall Brush 2-1/2" Thick Saplings	6' Tall Grass 8' Tall Brush 2-1/2" Thick Saplings	6' Tall Grass 8' Tall Brush 3" Thick Saplings	6' Tall Grass 8' Tall Brush 3" Thick Saplings	6' Tall Grass 8' Tall Brush 3" Thick Saplings
<b>Cutting Width</b>	26"	26"	30"	30"	34"	30"
<b>Cutting Height</b>	4"	4"	4"	4"	4"	4"
<b>Speeds</b>	3 Forward 1 Reverse	3 Forward 1 Reverse	3 Forward 1 Reverse	3 Forward 1 Reverse	3 Forward 1 Reverse	3 Forward 1 Reverse
<b>Power Steering</b>	No	Yes	Yes	Yes	Yes	Yes
<b>Tires</b>	18" x 6-1/2" x 8" All Terrain Sealant Filled	18" x 6-1/2" x 8" All Terrain Sealant Filled	18" x 6-1/2" x 8" All Terrain Sealant Filled	18" x 6-1/2" x 8" All Terrain Sealant Filled	18" x 6-1/2" x 8" All Terrain Sealant Filled	18" x 6-1/2" x 8" All Terrain Sealant Filled
<b>Machine Dimensions</b>	80.5" L 30.25" W 48.2" H	80.5" L 30.25" W 48.2" H	83" L 33" W 48.2" H	83" L 33" W 48.2" H	84.5" L 38" W 48.2" H	84.5" L 38" W 48.2" H
<b>Machine Weight</b>	268 lbs.	290 lbs.	303 lbs.	325 lbs.	339 lbs.	325 lbs.

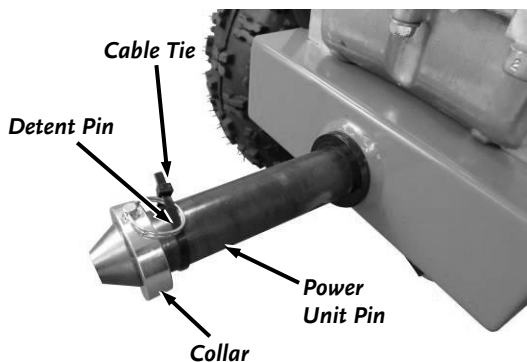

Figure 3

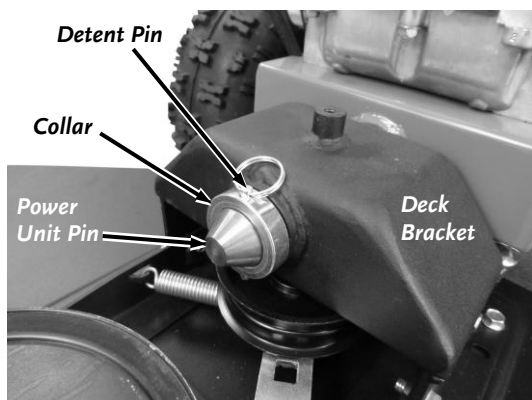

Figure 4

### SETUP for DR FIELD and BRUSH MOWER ATTACHMENTS:

The DR FIELD and BRUSH MOWER is shipped with a Brush Deck. It will also accept other attachments including the DR SNOWTHROWER, DR CHIPPER ATTACHMENT, DR LAWNDECK and DR SNOW/GRAVEL BLADE. Setup of these attachments is quick and easy. Instructions to install and remove the individual attachments can be found in their user manuals.

### Installing the Brush Deck

#### Tools and Supplies Needed:

- Gloves
- Wire Cutters

1. Cut Cable Tie and remove Detent Pin and Collar from Power Unit (**Figure 3**).
2. Slide the Power Unit Pin into the Deck Bracket and install the Collar and Detent Pin (**Figure 4**).
3. Remove the Belt from the Product Package.

4. Insert the belt over the Tensioner Spring and through the inside of the Deck Pivot Bracket (**Figure 5**).
5. Wrap the Belt around the Clutch Pulley under the Power Unit (**Figure 6**).

**⚠ CAUTION**

Your hands could get pinched when installing the Belt onto the Deck Pulley. Wear Gloves to prevent injury.

6. Start the Belt into the groove of the Deck Pulley and turn the Pulley as you guide the Belt around and into the Pulley groove (**Figure 7**).
7. Install the Belt Guard that was shipped with the machine and secure with the Knob from the product package (**Figure 8**).

**Connecting the Battery Wire (electric Start Models)**

We ship all Electric-Starting Mowers with the negative terminal Battery wire disconnected. This prevents the Battery from discharging during shipment. Before using your Mower, you must connect the Battery wire.

1. Connect the negative (black) wire to the negative terminal on the Battery by sliding the Connector onto the Terminal (**Figure 9**).

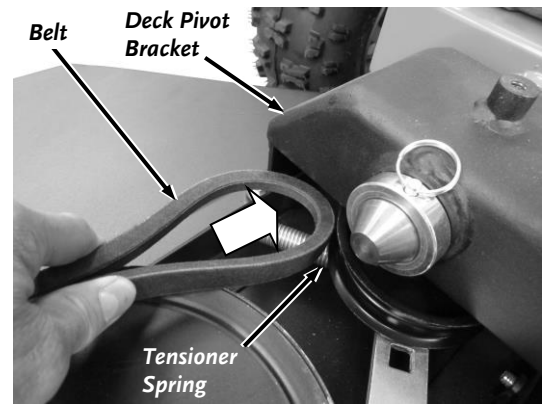

Figure 5

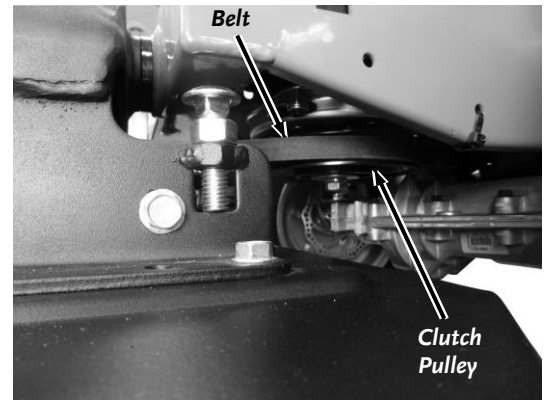

Figure 6

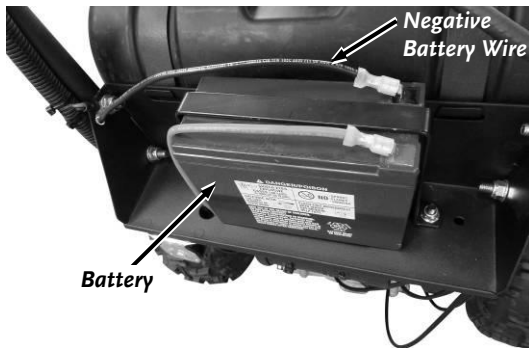

Figure 9

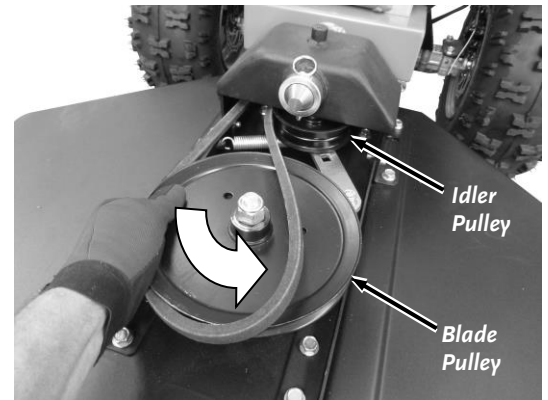

Figure 7

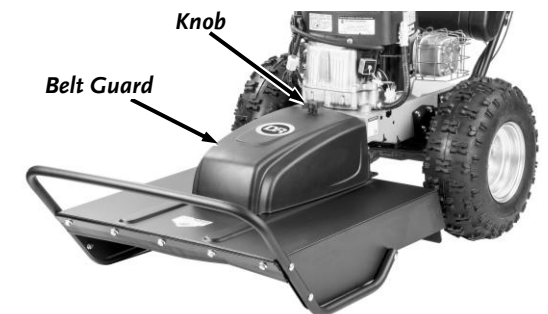

Figure 8



Figure 10: Electric Start Machines



Figure 11: Manual Start Machines

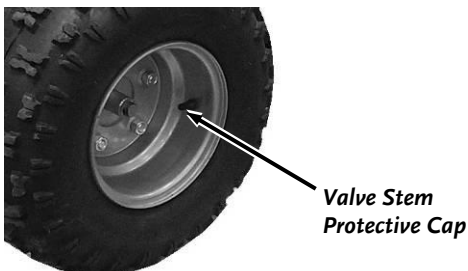

Figure 12

## Adding Oil and Gasoline

**Note:** Please refer to your Engine Owner's Manual for detailed oil information regarding Oil weight based on ambient temperature

1. Place the machine on a level surface and initially add 1/2 of oil recommended by the Engine manufacturer into the Oil Fill (**Figure 10, Electric Start Machines**) or (**Figure 11, Manual Start Machines**).
2. Wait one minute for the oil to settle and check the Dipstick. Continue adding a few ounces of oil at a time, rechecking the Dipstick until the oil reaches the full mark. Be careful not to overfill.

### **! WARNING**

Before filling the Fuel Tank; turn the Engine OFF, and let it cool at least five minutes before removing the Gas Fill Cap

3. Fill the Fuel Tank to not more than 1/4" from the bottom of the Fill Neck with fresh, unleaded gas. See your Engine Owner's Manual for more information.

### **NOTICE**

- **You must add Oil before starting the engine.** This machine is shipped without oil. Traces of oil may be in the reservoir from factory testing, but you must add oil before starting the engine. Fill the reservoir slowly, checking the level frequently to avoid overfilling.
- To get an accurate reading when checking the oil level:
  - The machine should be on a level surface.
  - The Dipstick SHOULD be screwed down on Briggs & Stratton Engines to ensure an accurate oil level reading.

## Check the Tire Pressure

**Tools Needed:**

- Tire Pressure Gauge
- Air Compressor

1. Remove the Valve Stem Protective Cap (**Figure 12**) and check the tire pressure with a Tire Pressure Gauge.
2. Compare the tire pressure reading from step 1 with the manufacturer's recommended tire pressure stamped on the side of the tire.
3. If the pressure is too low, add air through the Valve Stem with an air hose.

### **! WARNING**

Do not over inflate the tires. Inflate to the manufacturers recommended pressure found on the tires.

4. Replace the Valve Stem Protective Cap when finished.

## Handlebar Height Adjustment

We ship all DR Field and Brush Mowers with the handlebars in the highest position setting. If you would like to lower the handlebars to the Low position please follow these steps:

### Tools Needed:

- 9/16" Wrench
1. Remove Rear Handlebar Bolt with a 9/16" Wrench from both handlebars (**Figure 13**).
  2. Loosen Front Handlebar Bolt on both handlebars but do not remove.
  3. Align Handlebar Rear hole to Handlebar Low Position hole in the Frame.
  4. Reinstall Rear Bolts on both handlebars.
  5. Tighten Front and Rear Bolts on both handlebars.

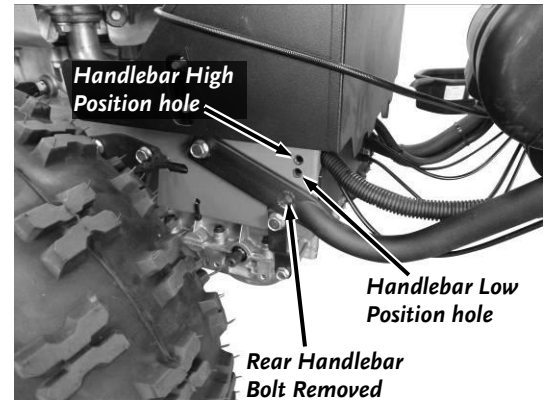

Figure 13

## Deck Pivot Bolt Check/Adjustment

There are two Deck Pivot Carriage Bolts on your DR Field and Brush Mower Deck. The machine should have been shipped with both Bolts in the lowest position (**Figure 14**). If they are not both in the lowest position, perform the following procedures.

**Note:** The Carriage Bolts should be adjusted all the way down for easy to moderate mowing. For aggressive mowing see "Cutting Brush and Saplings" in Chapter 3.

1. Loosen both Locknuts using a 3/4" Wrench as you hold the square portion of the Carriage Bolts using a 1/2" Wrench (**Figure 14**). Turn the Locknut up against the Bolt Head.
2. Turn the Carriage Bolts down using a 1/2" Wrench until the threaded end is contacting the Deck Bracket.
3. Turn the Locknut down against Deck Bracket and hold the Carriage Bolt as you tighten the Locknut.

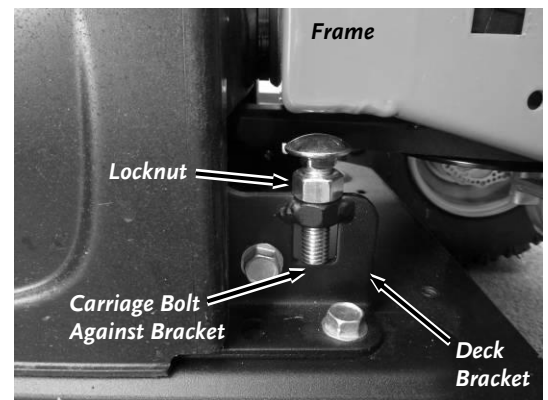

Figure 14

## Chapter 3: Operating the DR FIELD and BRUSH MOWER

---

You may find it helpful to review the DR FIELD and BRUSH MOWER Controls and Features in **Figure 2** on page 7 before reading this chapter.

Steering Brake Burnishing and Clutch Burnishing are very important procedures that must be done prior to using the Brush Mower to ensure optimum performance. Please read the following section to understand how to carry out these procedures before starting the machine and perform these procedures as soon as you get the machine started.

### ***Steering Brake Break-in (Burnishing)***

If your DR Field and Brush Mower is equipped with Steering Brakes, the Brake Pads and Rotors need to be broken in (burnished) during the first use to ensure the best performance. Please complete the following steps before using your machine and after you have read through Chapter 3:

---

#### **CAUTION**

Avoid contact with the Brake Calipers and Rotors during and after this procedure because the Brake rotors will become very hot and may burn you.

---

1. Refer to Chapter 3 to start the machine and shift into second gear.
2. Engage the Traction Drive Lever to drive the machine forward.
3. Apply both brakes equally with moderate force and hold the brakes on for 100 feet.
4. Release the brakes for 25 feet.
5. Re-Apply both brakes equally with moderate force and hold the brakes on for another 100 feet.

### ***Clutch Break-in (Burnishing)***

---

#### **NOTICE**

This machine must have the Clutch “Burnished” before initial use to ensure that the Clutch performs at its full potential. The longevity and efficiency of the Clutch will be compromised if this procedure is not performed.

---

The Blade Clutch on your machine should be burnished before use. This will ensure that the optimum engaging and braking action can be achieved. This procedure should be performed when the Clutch is new and before you use the machine for the first time.

1. The machine must be fully assembled and set up as detailed in this manual before performing the following burnishing procedures. Use these instructions along with the “Starting” and “Operating” sections of your manual.
2. Start the Engine and set the machine to half Throttle.
3. Engage the Blade Clutch for 2 seconds, disengage and let it cool down for 10 seconds.
4. Repeat step 3 for 50 cycles to fully burnish the Clutch.

## Before Starting the Engine

1. Check the Engine Oil level every time before you use the machine (**Figure 10/11** on page 10).
2. Check the gas level (**Figure 10/11** on page 10).
3. Ensure that the Fuel Shut-Off Valve located under the Fuel Tank is open (**Figure 15**).

## Starting



### ELECTRIC STARTING

1. Move the Wheel Speed Lever to Neutral **N** (**Figure 16**).

**Note:** The Wheel Speed Lever must be in Neutral and the Blade Control Knob pushed down (OFF), or the Engine will not start.

2. Check that the Neutral Safety Switch at the rear of the Transaxle is connected in case it has loosened during shipping (**Figure 17**).
3. Move the Throttle Lever to Choke , or pull up on the Choke Knob (if equipped) **Figure 16**.

**Note:** Move the throttle Lever to Fast  if the Engine is already warm.

4. Rotate Key to the Start position  until the Engine starts, then release.  
The Key will return to the Run  position and the Engine will continue to run.
5. After the Engine starts, push down the Choke Knob (if equipped) and move the Throttle Lever to the Fast  position.

### MANUAL STARTING (10.5HP MODEL)

1. Move the Shift Lever to Neutral **N** (**Figure 16**).

**Note:** The Wheel Speed Lever must be in Neutral and the Blade Control Switch pushed down (OFF), or the Engine will not start.

2. Move the Throttle to Choke 

**Note:** Move the Throttle Lever to Fast  if the Engine is already warm.

3. Rotate Key to the Run  position.

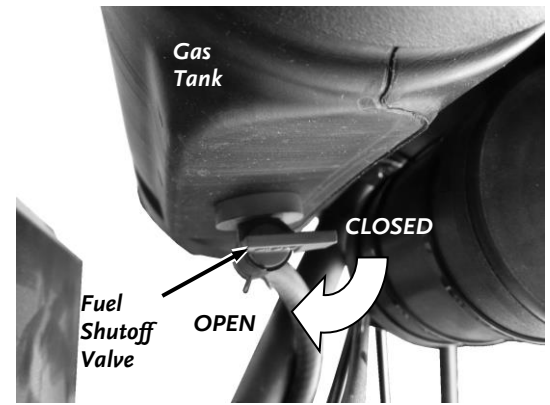

Figure 15

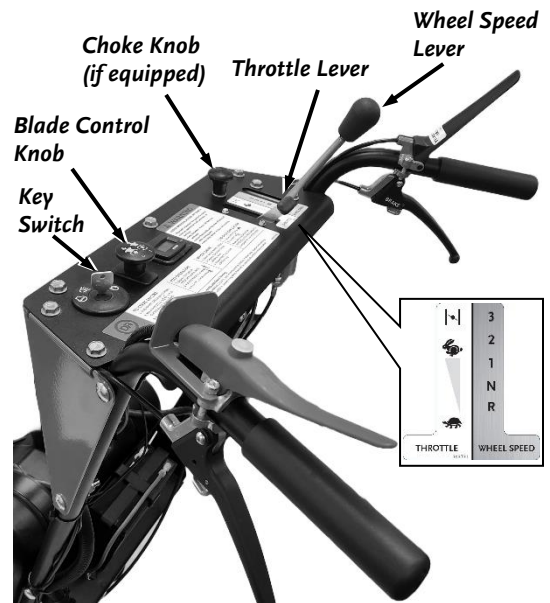

Figure 16

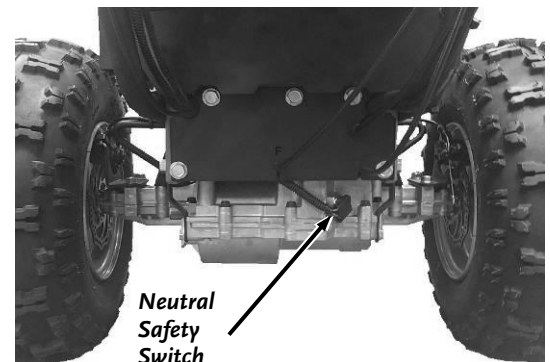



Figure 17

Pull Start Handle



Figure 18

- Grasp the Recoil Starter Handle and slowly pull until you feel resistance (**Figure 18**). Let the Cord retract a little bit, and then pull the Cord rapidly to start the Engine.
- When the Engine starts, move the Throttle to the Fast  position (**Figure 16**).

### Engaging the Wheel Drive

The DR FIELD and BRUSH MOWER has a three-speed Forward, single-speed Reverse Transmission. Speeds are generally used as follows:

- 1<sup>st</sup> Gear: Thick, woody vegetation.
  - 2<sup>nd</sup> Gear: Stalky material or Field Mowing.
  - 3<sup>rd</sup> Gear: Lighter Mowing or Transport mode.
- Reverse Gear is ideal for maneuvering in tight spots.

- While transporting the machine in 3rd Gear the Throttle can be used to adjust speed.
- When mowing the throttle should always be in the Fast Position.
- Mowing Speed may impact cutting performance. Mowing in a slower gear will improve cut quality.
- For best operator control of the DR Field and Brush Mower, always select a drive speed that matches the conditions. For example, use a slower speed when operating in wet, heavy growth, slippery, and/or steeply sloped areas.

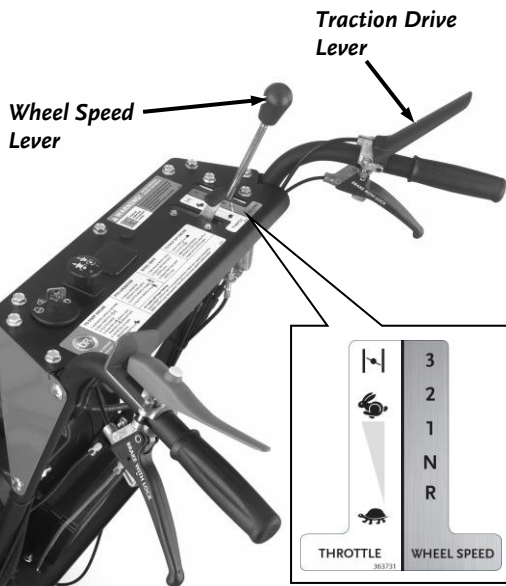

Figure 19

### NOTICE

Always release the Traction Drive Lever before shifting gears to prevent damage to the Transmission.

- Move the Wheel Speed Lever to the desired gear (**Figure 19**).
- Gently push down the Traction Drive Lever to engage the Wheels.
- Release the Traction Drive Lever if you need to slow down or stop.

### CAUTION

The steering brakes WILL NOT STOP the machine if the machine is in gear and Traction Drive Lever is engaged.

**Note:** If you have trouble shifting while on a hill or against an obstacle; lifting one tire off the ground will release the stress in the drivetrain and ease shifting.

### Engaging the Blade

- Push down the Operator Presence Lever against the Handlebar Grip (**Figure 20**).

- Engage the Blade by pulling up  on the Blade Control Knob.

**Note:** If you pull up on the Blade Control Knob before holding down the Operator Presence Lever, the Engine will shut off.

### CAUTION

Always disengage the blade of the DR FIELD and BRUSH MOWER before shifting into reverse.

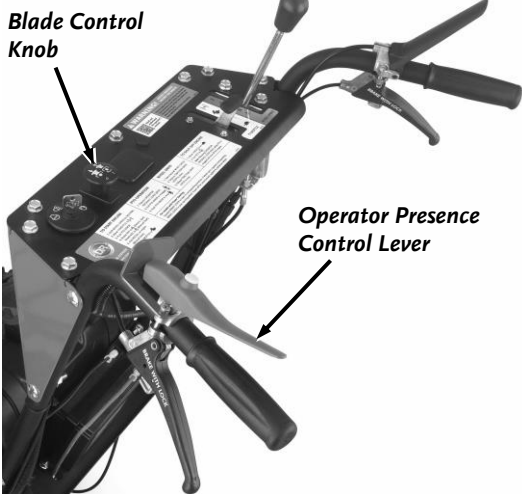

Figure 20

## Stopping the Blade

1. Stop the Blade by pushing down  on the Blade Control Knob (Figure 21).

**Note:** Releasing the Operator Presence Lever to disengage the Blade will cause the Engine to shut off.

## Stopping the Engine

1. Disengage the Blade by pushing DOWN  on the Blade Control Knob (Figure 21).

2. Move the Throttle Control to the IDLE  position.

3. Turn the Key to the Stop  position and remove it for safety.

**Note:** If your machine is equipped with a Fuel Shut-Off Valve, close it when transporting or storing the Mower.

## Obstacle Tips

Dealing with obstacles in the terrain is easy with your new DR FIELD and BRUSH MOWER. The following section explains how to approach most common obstacles.

### WARNING

The mower's blade can easily throw stones, sticks, and other debris at great velocity, which could cause personal injury or property damage. Do not run the machine over gravel driveways or over loose stones or mulch with the mower blade spinning.

- Always check your work area before mowing and remove any debris that might tangle or damage the machine.
- If you do run into debris and the mower becomes tangled, turn off the Engine, allow the engine to cool for 5 minutes and disconnect the Spark Plug wire(s) before attempting to untangle the machine.

## Operating the Steering Brakes (if equipped):

Steering brakes can assist the operator in:

- Shifting the drive power from one wheel to the other to improve traction.
- Keeping the mower driving straight on side slopes.
- Turning the machine left or right.

The brakes apply a stopping force to the wheel on the same side as the brake lever. For example, when the left lever is squeezed the brake slows or stops the left wheel and transfers transaxle power over to the right wheel.

## Steering with Brake Assist:

1. Select a Gear most applicable to the situation (see “Engaging Wheel Drive” on previous page).
2. Press down on the Traction Drive Lever to drive the machine (Figure 22).
3. Turn the machine to the left by squeezing the Left Brake Lever.
4. Turn the machine to the right by squeezing the Right Brake Lever.

**Note:** the machine must be driving for the brakes to assist with steering.

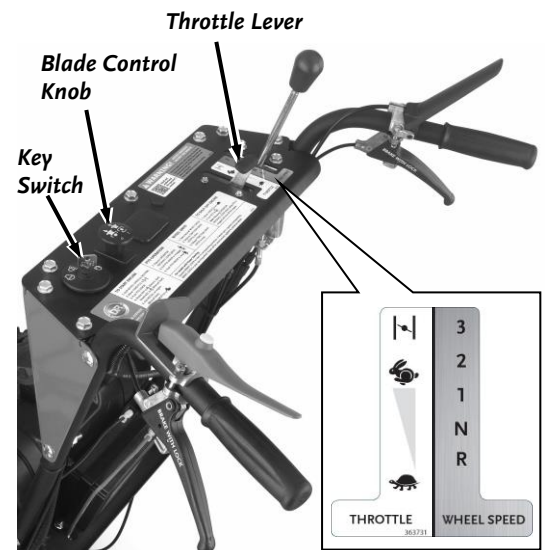

Figure 21

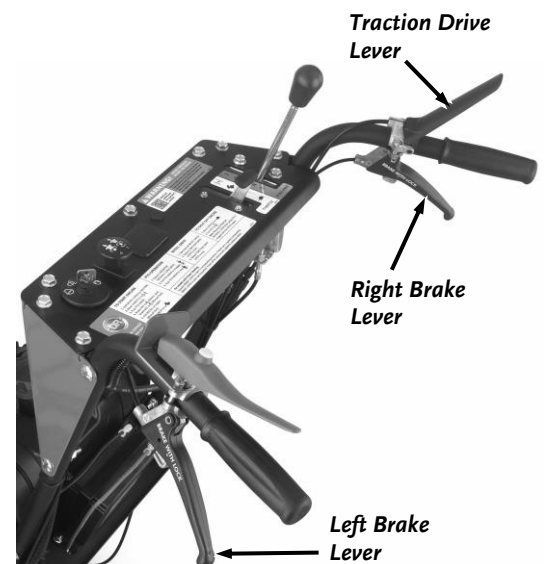



Figure 22

## Traction Control with Brakes:

Occasionally, the machine may lose traction on one or both wheels. To gain traction, perform the following steps:

1. Stop the Blade by pushing down  on the PTO Knob (**Figure 21**)
2. Apply the brake to the spinning wheel and the power will be directed to the wheel that has more traction.
3. If both wheels are spinning try alternating the brakes left and right to maneuver the machine through the obstacle.

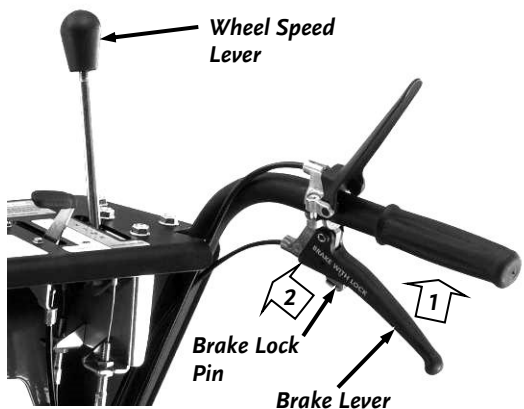

Figure 23

## Setting the Parking Brakes:

For machines equipped with Steering Brakes. Machines without Brakes should be put in 1st gear and parked on a level surface.

1. Shift the Wheel Speed Lever to Neutral **N** (**Figure 23**)
2. Squeeze one of the Brake levers and push the Brake Lock Pin forward to set the brake. The Brake Lever will stay up when locked properly.
3. Repeat step 2 for the other Brake.

## Mowing on Slopes

### **WARNING**

Slopes are a major factor related to slip and fall accidents. All slopes require caution. If you feel uneasy on a slope, do not mow it. Always take the following precautions when using this machine on slopes:

- Always mow across the face of slopes. Exercise extreme caution when changing direction on slopes.
- Never operate near drop-offs, ditches, or embankments, or on slopes greater than 20 degrees
- Never operate on wet or slippery slopes.
- When operating the DR FIELD and BRUSH MOWER over uneven terrain or slopes, use extreme caution not to tip the machine over.
- Do not use the DR FIELD and BRUSH MOWER on slopes greater than 20 degrees. Doing so could result in serious injury or damage to your machine.
- Do not shift while on a slope, doing so could result in a “free-wheel” condition.
- Be very careful of your footing when operating the machine in reverse. Know what's behind you and take your time.
- Disengage the Blade before shifting into reverse. Mow in the Forward gears only, using Reverse for maneuvering.

1. While mowing on sloped terrain, mow across the face of the slope. Do not mow up and down.
2. To avoid excessive speed, shift into a lower gear before going down a slope.

**Tip:** For machines equipped with steering brakes: When mowing on sidehills, feather the uphill brake to get the machine to steer up the hill slightly. This should keep the machine moving in a straighter line without additional operator effort.

## If the machine gets hung up

1. Disengage the Blade. Do not try to free the machine from stumps or debris with the Blade engaged.
2. Push down on the Handlebars to lift the Mowing Deck over the obstacle.
3. Shift the machine in reverse and try backing away from the obstacle.

## Cutting Brush and Saplings

### WARNING

If you need to leave the operating position to clear debris from the deck, stop the engine, wait five minutes to allow all parts to cool. Disconnect the spark plug wire(s), keeping it away from the spark plug(s).

#### DECK PIVOT BOLT ADJUSTMENT (aggressive mowing conditions)

For aggressive mowing (Brush and Saplings) the Deck can be held stationary so the Blade cuts with more stability.

**Note:** The Carriage Bolts should be adjusted all the way up for aggressive mowing. The entire machine must be on a flat surface for the following procedures.

#### Tools Needed:

- 1/2" Wrench
- 3/4" Wrench

1. Loosen both Locknuts using a 3/4" Wrench as you hold the square portion of the Carriage Bolts using a 1/2" Wrench (**Figure 24**).
  2. Turn the Carriage Bolts up using a 1/2" Wrench until the round heads are contacting the Deck Bracket.
  3. Turn the Locknut down against Deck Bracket and hold the Carriage Bolt as you tighten the Locknut.
- When cutting woody material, small saplings, etc., allow the machine to ride up and over material slowly. Adjust your forward speed to varying conditions.
  - After cutting brush, etc., you may want to mow over it again to remove any remaining branches. It works best to mow from the trunk end toward the top as brush lies on the ground.

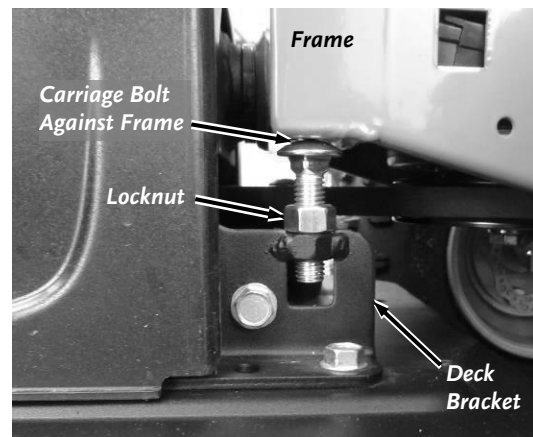

Figure 24

## Removing the Brush Deck

It is recommended that the deck only be removed when installing other attachments or performing maintenance.

### NOTICE

The Power Unit should always have an Attachment installed for stability.

#### Tools and Supplies Needed:

- Gloves
- Flat Head Screwdriver

1. Unscrew the Knob that secures the Belt Guard to the Deck and remove the Guard (**Figure 25**).
2. Place a screw driver between Blade Pulley and Belt.

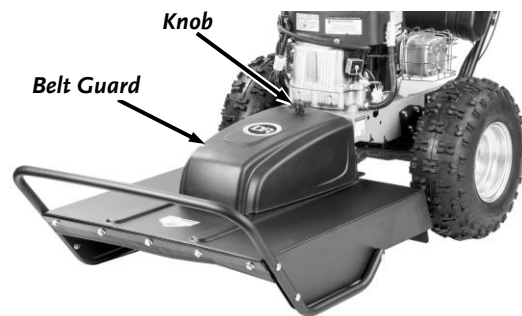

Figure 25

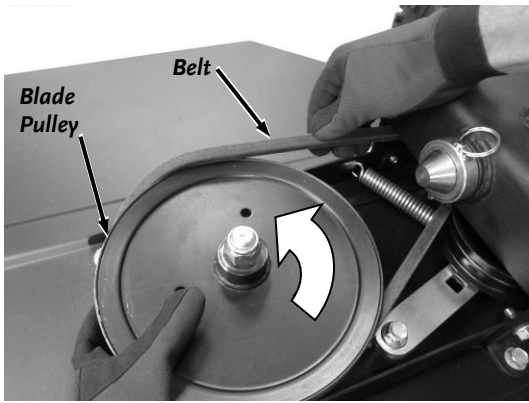

Figure 26

3. Rotate the Blade Pulley as you roll the belt off (**Figure 26**).
4. Push the belt in toward the Power Unit and the belt will fall off the Clutch Pulley (**Figure 27**).
5. Pull the belt toward the deck to remove the Belt entirely.
6. Remove the Collar and Detent pin (**Figure 28**).
7. Shift the Wheel Speed Lever into Neutral.
8. Pull the Power unit back to release the Power Unit Pin out of the Deck Pivot Bracket.

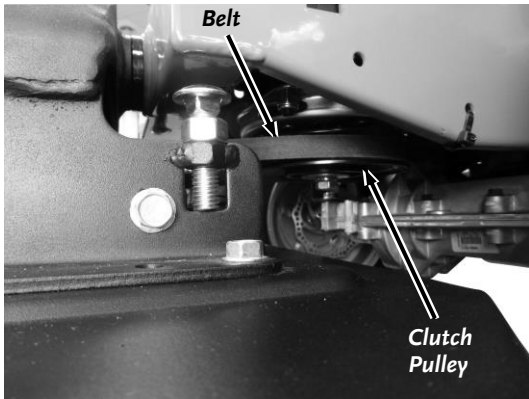

Figure 27

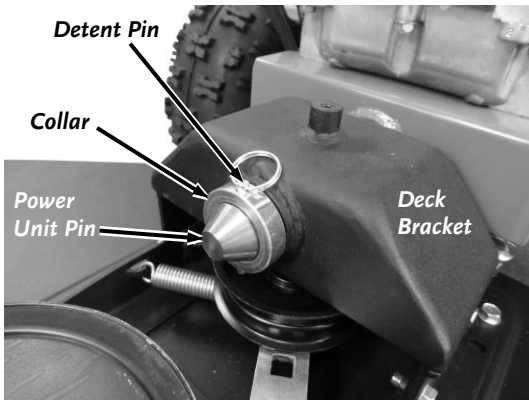

Figure 28

## Chapter 4: Maintaining the DR FIELD and BRUSH MOWER

Regular maintenance will ensure the best performance and long life of your machine. Please refer to this manual and the engine manufacturer's owner's manual for maintenance procedures. Service intervals listed in the checklist below supersede those listed in the engine manufacturer's owner's manual.

### **! WARNING**

- Before performing any maintenance procedure or inspection, stop the engine, wait five minutes to allow all parts to cool. Remove the Key and disconnect the spark plug wire(s), keeping it away from the spark plug(s)
- Always wear gloves when performing maintenance on the machine.

### Regular Maintenance Checklist

PROCEDURE	BEFORE EACH USE	EVERY 25 HOURS	EVERY 100 HOURS
Check Operator Presence Switch	▲		
Check Engine Oil Level	▲		
Check General Equipment Condition	▲		
Check Blade for Sharpness	▲		
Clean Engine Exterior and Cooling Fins	▲		
Check Blade Belt Condition (replace if damaged)	▲		
Check Brake Cables (adjust if needed)		▲	
Lubricate Grease Fittings		▲	
Lubricate Cables		▲	
Check Tire Pressures		▲	
Change Engine Oil and Filter**	1 <sup>st</sup> time 5 hours	▲ (10.5-17.5HP)	▲ (27HP CXI)
Check the Battery charge		▲	
Check cable connections		▲	
Replace Air Filter and Pre-cleaner**			▲
Replace Spark Plug(s)			▲
Replace Fuel Filter			▲

\*\* The Engine on your machine may not have a Pre-cleaner or Oil Filter.

## LUBRICATION

### Replacing Engine Oil and Filter

**Note:** Drain the oil when the Engine is warm. Warm oil drains quickly and completely.

#### Tools & Supplies Needed:

- Oil Filter Wrench (obtainable from a local auto parts or hardware store)
  - Oil (Refer To Engine Operator Manual for Oil info and Capacity)
  - Rags and an approved oil container
1. Position an approved oil container near the Oil Drain Hose.
  2. Turn the Oil Drain Cap a quarter turn counterclockwise and open the end of the Drain Hose Assembly (**Figure 29**).
  3. Remove the Oil Drain Hose Assembly from its stowed position and lower the drain end over the Oil Container to drain.

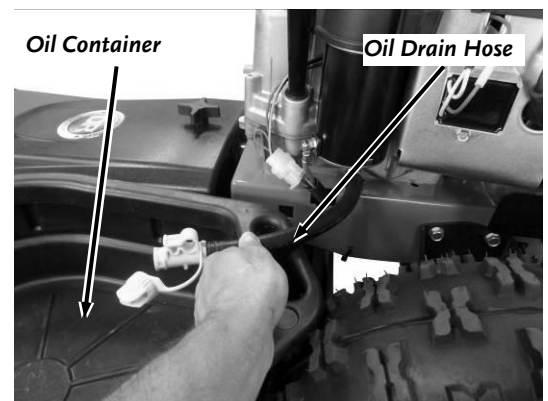

Figure 29

- If the engine has an oil filter, remove the old Oil Filter with an Oil Filter Wrench and replace with a new Oil Filter as described in the Engine Operator Manual.
- Replace the Oil Drain Hose Assembly onto the Storage Hook and close the Oil Drain Cap (Refer to “Adding Oil and Gasoline” on page 10).

## Cable lubrication

### Supplies Needed:

- Multi-purpose Teflon Aerosol Lubricant

Lubricate the Traction Drive Cable, Shift Cables, Throttle Cable and Brake Cables where the Cable goes into the Sheathing with a Multi-purpose Teflon Aerosol Lubricant

- Spray the lubricant into the Cable Housing while working the Cable back and forth a few times. Perform this lubrication more often in dry and dusty environments.

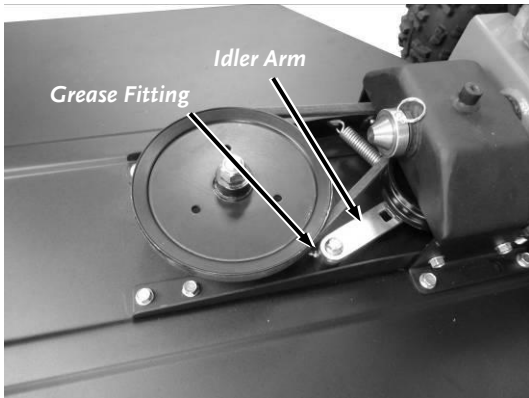

Figure 30

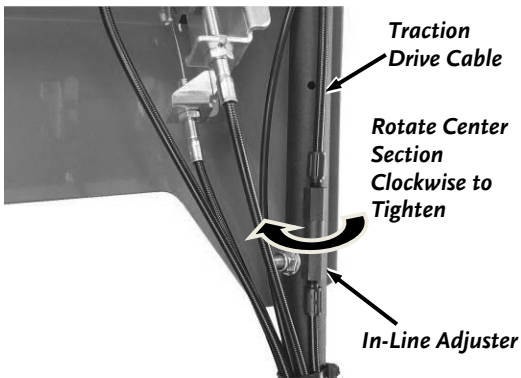

Figure 31

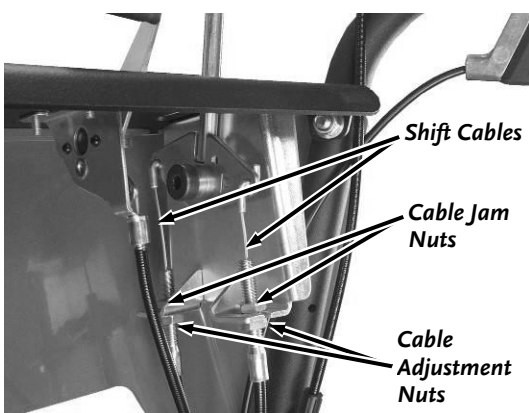

Figure 32

## Idler Arm Lubrication

### Tools & Supplies Needed:

- Grease Gun w/General Purpose Grease

There is one Grease Fitting below the black Belt Guard to lubricate (**Figure 30**) With the Blade Belt removed (Refer to “Removing the Brush Deck” on page 17), move the idler arm to make sure it rotates freely. If resistance is felt when pivoting the arm please lubricate as follows:

- Remove the knob and belt guard from the deck.
- Locate the Grease Fitting on the idler arm.
- Using the grease gun add a small amount of grease (1-2 pumps or until slight resistance).

**Note:** Over greasing may cause grease to leak onto the Mower Drive Belt.

- Reinstall the Belt (if removed) and Belt Guard.

## Adjusting the Traction Drive Cable

**Note:** When properly adjusted, tension on the Traction Drive Lever should increase when the Lever is about parallel to (almost touching) the Handlebar Grip.

- Locate the Traction Drive Cable along the right Handlebar (**Figure 31**). There is an In-Line Adjuster to change the length of the Cable.
- Rotate the center portion clockwise while holding the ends stationary to expand the In-Line Adjuster and remove slack from the cable.

## Adjusting the Shift Cables

If there is a lot of “play” in the Wheel Speed Lever or if the lever is no longer aligned with the Wheel Speed Label, you may need to adjust the Shift Cables.

### Tools needed:

- Two 13mm Wrenches

- Locate the Shift Cable Adjustment Nuts on the Shift Lever end of the cable (**Figure 32**).
- Loosen one of the Cable Jam Nuts on the cable using two 13mm Wrenches.
- Pull down slightly on the cable just enough to pull out the slack and then tighten the Cable Adjustment Nut to hold the cable housing in tension. You may need to tension one cable while loosening the other to realign the Lever.

**Note:** Do not over tighten the cable. It will create a spongy feel in the shift lever.

## Removing and Replacing the Blade Belt

### Supplies needed:

- Gloves

1. Unscrew the Hand Knob and remove the Belt Guard (*Figure 38*).

### **CAUTION**

Your hands could get pinched when removing or installing the Belt onto the Belt Pulley. Wear Gloves to prevent injury.

2. Turn the Belt Pulley with one hand while using the other hand to work the belt out of the Pulley groove (*Figure 39*).
3. Push the belt in toward the Power Unit and the belt will fall off the Clutch Pulley (*Figure 40*).
4. Pull the Belt toward the Deck to remove the Belt completely.
5. To install a new Belt insert the belt over the Tensioner Spring and through the inside of the Deck Pivot Bracket (*Figure 41*).
6. Wrap the Belt around the Clutch Pulley under the Power Unit (*Figure 40*).
7. Start the Belt into the groove of the Blade Pulley and turn the Pulley as you guide the Belt around and into the Pulley groove (*Figure 42*).
8. Install the Belt Guard back over the Belt and secure it with the Hand Knob (*Figure 38*).

## Drive Belt

The Drive Belt should not need replacing under typical working conditions. If it does become necessary to replace the Drive Belt due to unexpected damage, please contact us at [DRpower.com](http://DRpower.com) or call toll-free 1-800-DR-OWNER (376-9637) and one of our Technical Support Representatives will be happy to help you.

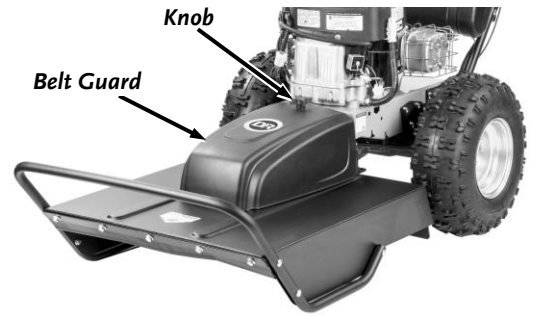

Figure 38

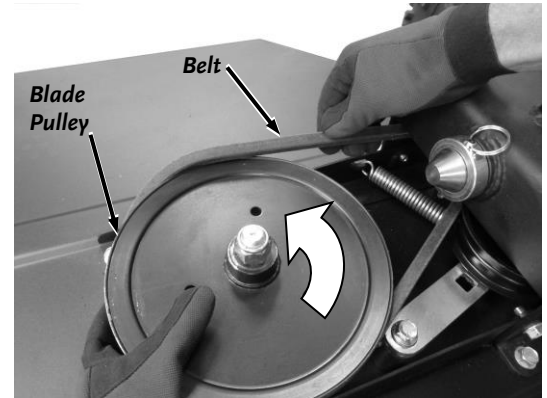

Figure 39

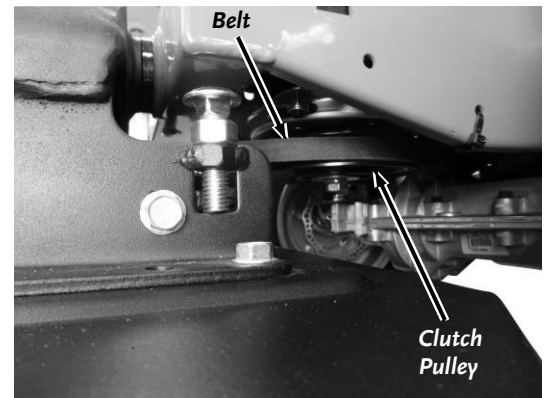

Figure 40

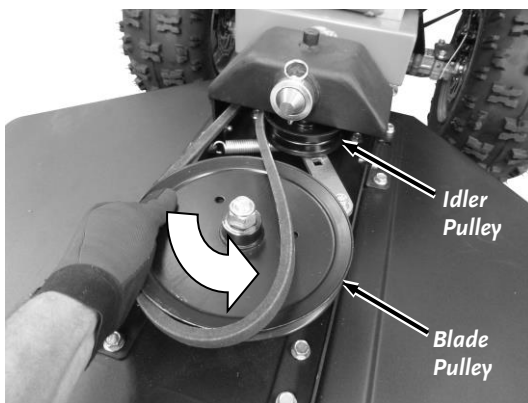

Figure 42

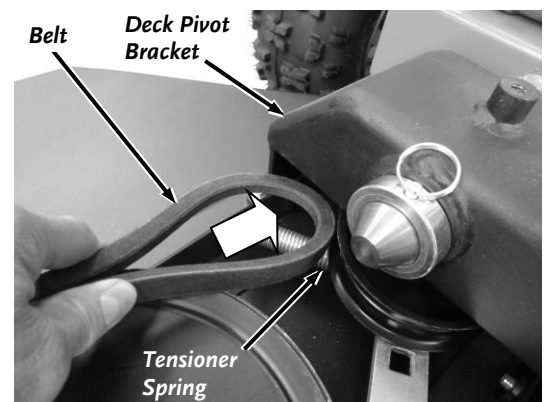

Figure 41

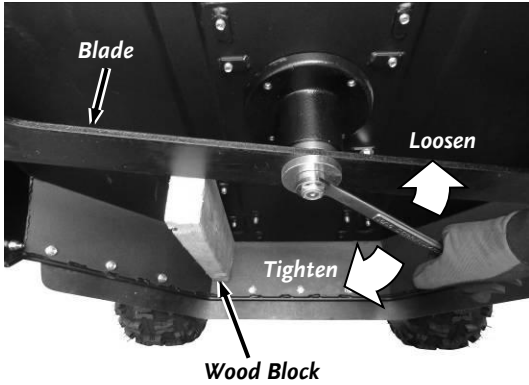

Figure 43

## Removing and Replacing the Blade

Replace the Blade when worn or damaged, but do not use it for over five years.

### Tools and Supplies needed:

- 15/16" Wrench or Socket
- Torque Wrench (optional)
- Gloves
- 2" x 4" to brace the Blade

1. Block the Blade with a piece of wood between the Blade and the Skid on the side of the Deck (**Figure 43**).
2. Remove the Blade Lock Nut (standard, right-hand thread) and Washer.
3. Remove the Blade.
4. Mount the new Blade, Washer, and Lock Nut and tighten securely (Torque to 100 ft-lbs.). If the Locknut is removed and installed more than once, it should be replaced with a new one.

**NOTE:** Be sure to seat the Blade completely over the small ridge in the Spindle Hub before tightening the Lock Nut.

## Removing the Wheels

### Tools and Supplies needed:

- 3/4" Socket with extension

1. Loosen the Wheel Nuts a couple of turns with the Wheel on the ground.
2. Block the machine so the Wheel you are removing is off the ground.
3. Remove the Five Nuts and slide the Wheel off.
4. Replace the Wheel and finger-tighten the Wheel Nuts before unblocking the machine.
5. Tighten the Wheel Nuts with the Wheel resting on the ground.

## Replacing the Blade Pulley

The Bladed Pulley is designed to protect the drive system of the machine. If the machine is overloaded the hub and pulley may fail. Please follow these instructions to replace

### Tools and Supplies Needed:

- 15/16" Wrench

1. Unscrew the Hand Knob and remove the Belt Guard (**Figure 44**).
2. Remove the Belt from the Pulley (Refer to "Removing and Replacing the Blade Belt," above).
3. Block the blade with a piece of wood (**Figure 43**) as you remove the Locknut using a 15/16" Wrench (**Figure 45**).
4. Remove the damaged Pulley and replace with a new Pulley.
5. Secure the Pulley with the Locknut and torque to 50lb-ft (68N-m).
6. Install the Belt (Refer to "Installing the Brush Deck" on page 8).
7. Replace the Belt Guard and Hand Knob.

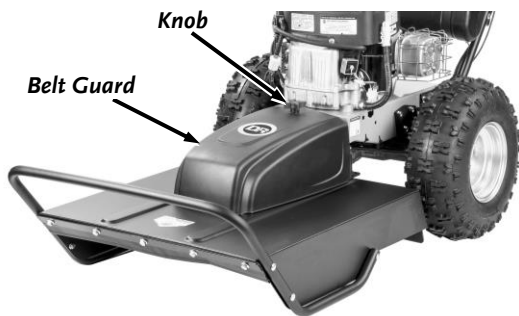

Figure 44

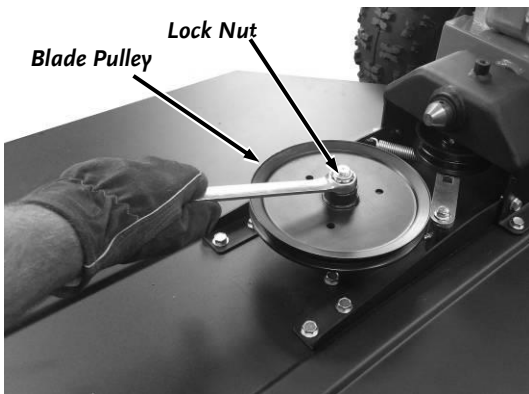

Figure 45

## Adjusting the Brake Cables

### Tools needed:

- 5.5mm Allen Wrench

On each brake caliper there is a tool free Micro Adjust Knob (**Figure 46**). For most maintenance this knob can be unscrewed and will tension the cable.

Once the Micro Adjust Knob is close to the end of its thread travel, it is recommended to do a full adjustment.

**Note:** Although not mandatory, it is recommended that the wheel be removed before completing a full adjustment.

1. Screw the Micro Adjust Knob all the way back into the caliper.
2. Using the 5.5mm Allen Wrench, loosen the Cable Clamp.
3. Pull the cable through the clamp removing and slack in the cable.
4. While holding tension on the cable, retighten the Cable Clamp with the 5.5mm Allen wrench.

## Adjusting the Brake Pads

### Tools needed:

- 5.5mm Allen Wrench

**Note:** Brake Pads may need adjustment after the pads wear significantly

1. Remove the wheel from the side that needs adjusting.
2. Locate the Pad Adjustment Screw on the outboard side of the caliper (**Figure 47**).
3. Tighten the adjustment screw using the 5.5mm Allen wrench until just before the Brake Pad just touches the Brake Rotor.

## Adjusting the Caliper Alignment

### Tools needed:

- 5.5mm Allen Wrench

**Note:** Caliper Alignment should only be done after the Brake Pads have been adjusted

1. Remove the wheel from the side that needs adjusting.
2. Using the 5.5mm Allen Wrench, loosen the Caliper Mounting Bolts 1 turn (**Figure 48**).
3. While manually squeezing the caliper closed on the Brake Rotor, Retighten the Caliper mounting Bolts.

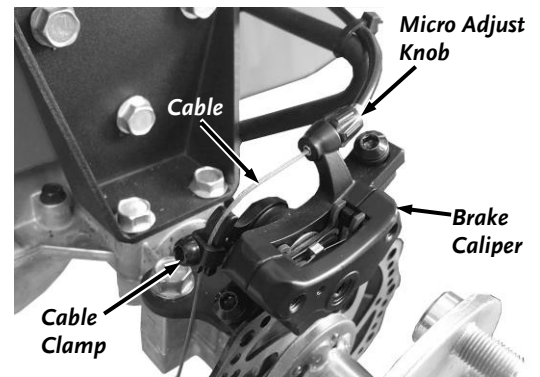

Figure 46

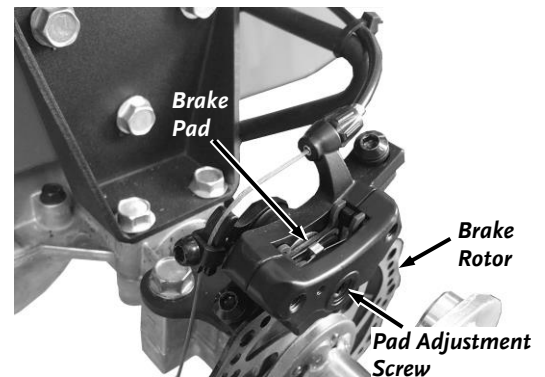

Figure 47

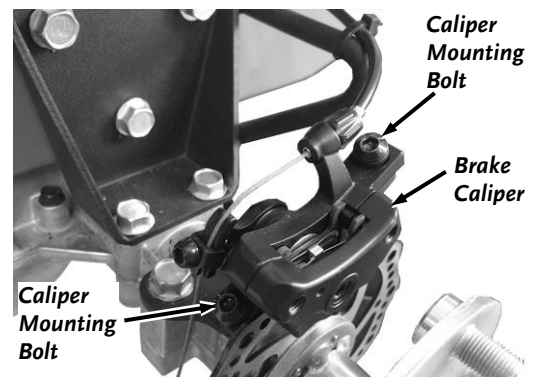

Figure 48

## **Battery Care (electric start machines only)**

Proper care can extend the life of a Battery. Follow these recommendations to ensure your Battery's best performance and long life:

- Do not allow the Battery charge to get too low. If the machine is not used, charge the Battery every 4 – 6 weeks. Operate the Engine for at least 45 minutes to maintain proper Battery charge.
- Store an unused Battery in a dry area that does not freeze.
- Do not charge an already charged Battery. In theory, you cannot overcharge our Battery with a trickle Charger; however, when a Battery is fully charged and the Charger is still on, it generates heat that could be harmful to the Battery. A fully charged Battery will read 12V-13.2V with a Voltmeter.
- Do not continue to crank the Engine when the Battery charge is low.

## **Charging the Battery**

Operate the Mower Engine for at least 45 minutes to maintain proper Battery charge. If the Battery loses its charge, you'll need to use a trickle Charger (like the DR Battery Charger) to recharge it. The Charger should have an output of 12 volts at no more than 2 amps.

**Note:** *The charging system of a running engine is designed to maintain a battery's present charge. Starting a machine that has a significantly discharged or dead Battery using the Recoil Starter or Jumper Cables will not recharge the Battery.*

To connect a Battery Charger to your DR FIELD and BRUSH MOWER, follow the steps listed below.

1. Detach the two Battery wires going to the Battery on your DR FIELD and BRUSH MOWER.
2. Attach the black (-) Battery Charger wire to the Battery negative (-) terminal, and attach the red (+) Battery Charger wire to the Battery positive (+) terminal.
3. Plug the Battery Charger into an outlet.
4. Charge until Battery Charger indicates that it is charged or Battery measures to 12-14V.
  - At 1 amp, you may have to charge the Battery for as long as 24 hours.
  - At 2 amps, you may have to charge the Battery for as long as 12 hours.
5. Once Charged, disconnect Charger from outlet.
6. Disconnect Battery from the Charger.

## **Disposing of the Battery Responsibly**

The Battery is a sealed lead-acid Battery. Recycle or dispose of it in an environmentally sound way.

- Do not dispose of a lead-acid Battery in a fire; the Battery may explode or leak.
- Do not dispose of a lead-acid Battery in your regular, household trash. Laws in most areas prohibit incinerating, disposing in a landfill, or mixing a sealed lead-acid Battery with household trash.

---

### **NOTICE**

Please dispose of used batteries responsibly, according to your local hazardous materials regulations. Never throw away used batteries in your household trash.

---

## **Recycling a Used Battery**

Please dispose of your used Batteries responsibly by recycling them. Call your local Solid Waste Management District or your local waste handler to locate the collection site nearest you. Some collection sites recycle Batteries year-round; others collect them periodically.

You can also visit the Web site of Earth 911 for more information [[www.earth911.org](http://www.earth911.org)]. Once there, click the Municipal HHW link under Hazardous Household Waste, and enter your zip code. The site lists recycling centers located near you.

For a fee, you can recycle your Batteries with the International Metals Reclamation Company. Visit them at [www.inmetco.com](http://www.inmetco.com) and click Services; or contact them at: INMETCO, PO Box 720, 245 Portersville Road, Ellwood City, PA 16117, (724) 758-2825; fax (724) 758-2845.

To learn more about hazardous waste recycling, visit the Web site for Battery Council International [[www.batterycouncil.org](http://www.batterycouncil.org)] or for the Environmental Protection Agency [[www.epa.gov](http://www.epa.gov)].

## Chapter 5: Troubleshooting

Most problems are easy to fix. Consult the Troubleshooting Table below for common problems and their solutions. If you continue to experience problems, contact us at [www.DRpower.com](http://www.DRpower.com) or call toll-free 1-800-DR-OWNER (376-9637) for support.

### **WARNING**

Before performing any maintenance procedure or inspection, stop the engine, wait five minutes to allow all parts to cool. Disconnect the spark plug wire(s), keeping it away from the spark plug(s).

### Troubleshooting Table

SYMPTOM	POSSIBLE CAUSE
<i>Engine Starter Won't Crank</i>	<ul style="list-style-type: none"> <li>⇒ Check all of the items under the section called "Starting" on page 13. Especially, - that the Transmission is in (N) and the PTO switch is in the depressed position</li> <li>⇒ Check that the Plug for the Neutral Safety Switch is connected</li> <li>⇒ Check the fuse located under the battery</li> <li>⇒ Check the battery is more than 12V- Refer to Battery Care Section</li> <li>⇒ Check all wire connections—especially the ground connections located on the handlebar and all of the connections on the solenoid. Disconnect the green Battery ground wire first to avoid sparks. Check to be sure that all of the connections are clean and tight. Reconnect the Battery ground wire.</li> </ul>
<i>Engine Starter Cranks but Engine won't start</i>	<ul style="list-style-type: none"> <li>⇒ Check that the gas tank is at least half full and that the fuel shut off is in the ON position</li> <li>⇒ Check that the fuel solenoid switch on the carburetor bowl is connected</li> <li>⇒ Try starting with the throttle in the CHOKE position; if this doesn't work try the RUN position.</li> </ul>
<i>The Engine lacks power or is not running smoothly.</i> <i>(Please refer to the Engine Owner's Manual for engine-specific procedures.)</i>	<ul style="list-style-type: none"> <li>⇒ Check the Throttle Lever travel and adjustment. Make sure the Throttle Lever is in the Run position.</li> <li>⇒ Check that the Air Filter is clean. If it is dirty, change it following the procedure in the Engine Owner's Manual.</li> <li>⇒ The Spark Plug(s) may be dirty or cracked, change it. If it's oily, leave it out, hold a rag over the Plug Hole(s) and crank the Engine several times to blow out any oil in the Cylinder(s), then wipe off the Plug(s) and reinsert it.</li> <li>⇒ The gas may be old, change it. Use a fuel stabilizer if you keep gas longer than one month.</li> <li>⇒ Check the Fuel Filter, it may be clogged. Replace if necessary.</li> <li>⇒ Check to make sure that your Engine has the right amount of clean oil. If it is dirty, change it following the procedure in the Engine Owner's Manual.</li> </ul>
<i>Engine smokes.</i>	<ul style="list-style-type: none"> <li>⇒ Check the oil level and adjust as needed.</li> <li>⇒ You may be operating the machine on too great an incline. See "Mowing on Slopes" on page 16.</li> <li>⇒ Check the Air Filter and clean or replace if needed.</li> <li>⇒ You may be using the wrong oil—too light for the temperature. Refer to your Engine Owner's Manual for detailed information.</li> <li>⇒ Clean the Cooling Fins if they are dirty.</li> <li>⇒ If the Engine still smokes, visit our web site at <a href="http://www.DRpower.com">www.DRpower.com</a> for assistance.</li> </ul>
<i>Traction Drive does not Engage</i>	<ul style="list-style-type: none"> <li>⇒ The Drive Belt is broken or out of adjustment. See page 21.</li> <li>⇒ Traction Drive Cable may need adjusting</li> </ul>

## Troubleshooting Table (Cont.)

SYMPTOM	POSSIBLE CAUSE
<i>Machine is difficult to shift</i>	<ul style="list-style-type: none"> <li>⇒ There may be added resistance from the driveline when trying to shift on a slope or while pressing against an obstacle. Lifting one tire will relieve any residual load in the driveline and shifting should become much easier.</li> <li>⇒ If there is resistance between all gears, the shift cables may be overly tight. Loosen 1 cable slightly and shifting feel should improve.</li> </ul>
<i>A Belt frays or rolls over the Pulley.</i>	<ul style="list-style-type: none"> <li>⇒ A Pulley groove may be rusty or have a nick in it. Clean the pulley with steel wool or file off any nicks.</li> <li>⇒ Check the Belt for wear and hard spots.</li> <li>⇒ The Belt may be stretched, replace it.</li> </ul>
<i>Excessive vibration when engaging the Blade.</i>	<ul style="list-style-type: none"> <li>⇒ Check the Blade for nicks and wear. Replace or sharpen and balance the Blade if they become dull, or have them professionally sharpened if needed. Never try to straighten a bent Blade. Be sure to replace the Blade in the proper orientation. See page 22.</li> <li>⇒ May have debris wrapped around Blade (wire, etc.), Remove debris from Blade.</li> <li>⇒ The Blade may not be seated properly on the Hub. Loosen the Blade Nut, reseal the Blade, and tighten the Nut. Be sure to turn OFF the Engine and remove the Spark Plug wire(s) before performing this operation.</li> <li>⇒ Check and retighten all of the fasteners as required.</li> </ul>
<i>The Blade is not cutting or is loose.</i>	<ul style="list-style-type: none"> <li>⇒ The Blade may not be seated properly on the Hub. Loosen the Blade Nut, reseal the Blade, and tighten the Nut. Be sure to turn OFF the Engine and remove the Spark Plug wire(s) before performing this operation.</li> <li>⇒ Sharpen the Blade; it may be dull or nicked. Be sure to replace the Blade in the proper orientation. See page 22.</li> </ul>
<i>The Blade will not Engage and/or Disengage.</i>	<ul style="list-style-type: none"> <li>⇒ Be sure you are holding down on the Operator Presence Lever.</li> <li>⇒ Be sure that all electrical plugs are connected (Both plugs at the control panel and plug to electric clutch)</li> </ul>
<i>Wheels pulling left or right.</i>	<ul style="list-style-type: none"> <li>⇒ Check the Wheel Tire pressures against the manufacturer's recommendation listed on the side of the Tires.</li> </ul>
<i>Bad Brake Performance</i>	<ul style="list-style-type: none"> <li>⇒ Be sure that all cables are adjusted properly and that cables are not kinked</li> <li>⇒ Caliper may not be adjusted properly, Refer to page 23 for caliper adjustments.</li> <li>⇒ Pads and Rotors may not be aligned properly.</li> <li>⇒ Pads and Rotors may not be burnished properly, Refer to page 12 for burnishing procedure</li> <li>⇒ Pads/Rotors may have oil contamination. Clean rotor with Brake Cleaner, and re-burnish the Brake Pads/Rotors. If problem persists replace Brake Pads.</li> </ul>
<i>Levers are hard to moved during cold weather operation</i>	<ul style="list-style-type: none"> <li>⇒ Moisture is getting into the Cable housing(s) and freezing. Using a lubricating syringe, inject "dry gas" into the Cable-Housing opening to absorb the moisture. Tip the machine forward slightly so the "dry gas" will flow down the inside of the Housing. After the ice blockage has thawed, lubricate the cable(s) with SAE 30 oil. See page 20.</li> </ul>

## Chapter 6: Parts Lists and Schematic Diagrams

### Parts List - Handlebar Assembly

**Note:** Part numbers listed are available through DR Power Equipment.

Ref#	Part#	Description	Ref#	Part#	Description
1	139051	Cable, Throttle, 50"	26	A0004764080	Grip, 1 In Id X 5.1 In L, Black
	353171	Cable, Throttle, 61" (10.5HP Only)	27	A0004170642	Lever Assembly, Traction Drive
2	* 352831	Tank, Gas, Assembly, EPA/CARB	28	351181	Cable, Traction Drive
3	* 344321	Bracket, Battery	29	10000037796	Control Panel, AT4
4	* 344431	Strap, Tank	30	A0000166161	Label, PRO 26
5	* 333321	Nut, Nylon Lock, Flanged, 5/16-18		A0000166162	Label, PRO XL30
6	* 385301	Carbon Canister, 300cc, 3/16" Ports		A0000166156	Label, PRO MAX34
7	* A0004114794	Strap, Battery 10AH	31	111731	Bolt, HCS, Serrated Flange, 5/16-18 X .50"
8	* 134471	Battery, 12v, 9Ah	32	351311	Cable, Shift
9	* 312831	Nut, Lock, 1/4-20, Serrated Flange	33	150361	Knob, PTO Clutch Cable
10	* 350331	Bolt, Carr, 5/16-18 X 1.75", GR5, ZP	34	164971	Guard, Switch, Magura
11	* 127971	Cable Tie, 17", # 50	35	352771	Panel, Control, With Label
12	* 351151	Cable, Brake		A0006923782	Panel, Control, With Labels (27HP)
13	A0004170631	Lever Assembly, Brake W/Lock	36	352761	Label, Control Panel, Top
	370511	Bracket, Lever Control (10.5HP only)		A0006776178	Label-Control Panel Operation AT4 (27HP)
14	112141	Cable Tie, 7-1/2" Long	37	363721	Label, Warning
15	352811	Bolt, Hex, Flange, Tri Lobe, 3/8-16 X 3/4", GR5, ZP	38	363731	Label, Wheel Speed and Throttle
16	A0006813651	Harness, Wire, ES, B&S	39	151311	Plug, Hour Meter Hole, 2" X 1-1/4"
	359821	Harness, Wire, MS, B&S	40	352901	Bolt Shoulder, 1/2" X 5/8", 3/8-16
17	344281	Handlebar, Left	41	150491	Screw 8-32 x 1/2"
18	344291	Handlebar, Right	42	190031	Plug, Plastic, 1/2" Hole
19	165191	Switch, Snap-In, E/S	43	179231	Screw, SHCS, M6 X 25mm
20	157201	Key, Ignition Switch	44	363531	Harness, Ground
21	191231	Switch, Push/Pull	45	deleted	
22	333331	Nut, Nylon Lock, Flanged, 3/8-16	46	112491	Washer, Star, Internal, 3/8", ZP
23	A0000253527	Lever, Shift	47	* A0000313387	Clamp, Fuel Line
24	A0000253528	Mount, Lever, Shift	48	* 265811	Clamp, Vapor Line
25	A0004170644	Lever Assembly, Operator Presence	49	* A0000522190	Hose, Fuel, CA Cert
			50	* 10000040536	Hose, Vapor, 3/16

#### Items Not Illustrated:

A0006776084 Cable-Choke-B&S 27hp  
(27HP Model)

# Schematic – Handlebar Assembly

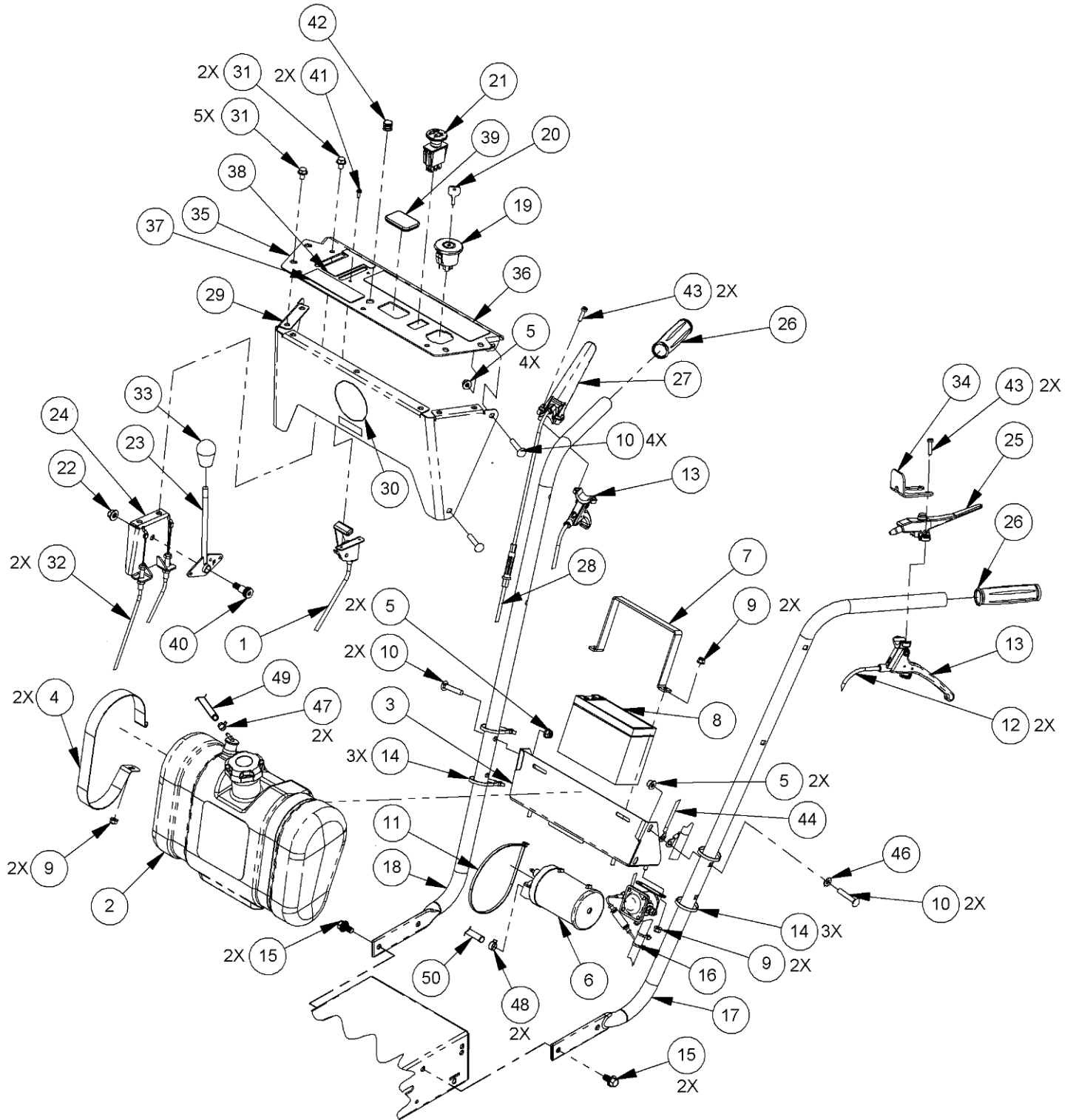

## Parts List – Power Assembly

**Note:** Part numbers listed are available through DR Power Equipment.

Ref#	Part#	Description	Ref#	Part#	Description
1	A0000862359	Frame, Main AT4	27	344231	Pulley, Keyed, A V-Belt, 2.5" OD, 1" Shaft
2	112411	Washer, Flat, 5/16" USS (20 & 27HP Only)	28	151381	Pivot Washer, 1.375"ID, 2.0"OD
3	344481	Engine B&S, 20HP V-Twin, ES, w/ Labels and Horizontal Exhaust	29	A0000757044	Bracket, Axle Mount, Left
	A0006924348	Engine B&S, 27HP V-Twin, ES, w/ Labels and Horizontal Exhaust		A0000757054	Bracket, Axle Mount, Right
	A0003207565	Engine, B&S 17.5HP Intek, ES w/Labels	30	344361	Pulley, Transaxle
	A0003207567	Engine, B&S 15.5HP Intek, ES w/Labels	31	111241	Snap Ring, External, 5/8"
	370681	Engine, B&S, 10.5HP Power Built, MS, 6Pin w/ Labels	32	247391	Idler Arm, Drive, FBP
4	A0001276226	Muffler, BS 20HP Horizontal (20 & 27HP Only)	33	151111	Bushing, 0.390" ID X 0.620" OD X 1.585"
5	341301	Gasket, Exhaust, Briggs, 20HP V-Twin (20 & 27HP Only)	34	108501	Pulley, Flat Idler, 3"
6	350561	Bolt, Muffler, B&S, (20 & 27HP Only)	35	333331	Nut, Nylon Lock, Flanged, 3/8-16
7	110761	Nut, Nylon Lock, 5/16-18 (20 & 27HP Only)	36	333481	Bolt, Hex, Flange, 3/8-16 X 2.5"
8	A0006792954	Guard, Exhaust, B&S V-Twin (20 & 27HP Only)	37	351101	Belt, AK32, 1/2" X 34"
9	363611	U-bolt, 1-1/8" ID, 1/4-20 x 1" (20 & 27HP Only)	38	A0000159802	Bracket, Shift, Transmission w/Washer
10	312831	Nut, Lock, 1/4-20, Serrated Flange (20 & 27HP Only)	39	A0000757072	Hanger, Rear Transaxle, Left
11	363561	Transaxle, 3spd, w/ Switch, Peerless		A0000757074	Hanger, Rear Transaxle, Right
12	333321	Nut, Nylon Lock, Flanged, 5/16-18	40	111731	Bolt, HCS, Serrated Flange, 5/16-18 X .50"
13	192891	Wheel, 18 X 6.5-8, Terrain, 5 Lug	41	351371	Support, Frame, Rear, Peerless
14	165221	Nut, Lug 1/2-20	42	A0000253469	Washer, 1.38"ID 2.0"OD .5"L
15	A0000253509	Hub, Wheel	43	150461	Pin, Detent, 1/4" X 2"
16	* 344461	Caliper, Mechanical Disc with Pads	44	353031	Guide, Belt, Traction Drive
17	* 344371	Mount, Brake	45	A0000367010	Washer, Lock, 7/16", Split, ZP
18	* 344471	Rotor, 140mm	46	191301	Washer, Flat, .469" X 1.62" X .25"
19	* 352721	Bolt, Torx, BHCS, M5-0.8 X 10mm, Cl8.8, ZP	47	A0001572401	Bracket, Anti Rotation, Ogura Clutch, AT4
20	* 112141	Cable Tie, 7-1/2" Long	48	352611	Spring, Extension
21	* 352811	Bolt, Hex, Flange, Tri Lobe, 3/8-16 X 3/4", GR5 ZP	49	101191	Key, Square, 3/16" X 2"
22	* 363591	Washer, Alignment, Female, M6	50	129691	Shim, .75"ID, 1.125"OD, .06"L, ZP
23	* 363581	Washer, Alignment, Male, M6	51	A0000313388	Ring, Retaining, 3/4" E-Clip
24	* 363601	Bolt, Alignment, M6-1 X 25, w/ Locking Patch	52	157121	Bolt, HCS, 3/8-16 X 2-1/4", GR5, ZP
25	370501	Clutch, Electric	53	370701	Key, Square, 1/4" X .75"
26	364381	Harness, Safety, Neutral	54	A0000929782	Hanger, Exhaust, 4.51" (20 & 27HP Only)
			55	111501	Bolt, SHCS, 1/4-18 X 3/4", Black Oxide
			56	A0000366994	Bolt, HCS, 7/16-20 x 2.25", GR8, ZP
			57	350511	Spacer, Idler
			58	112491	Washer, Star, Internal, 3/8", ZP
			59	111581	Bolt, HCS, 5/16-18 X 1", GR5, ZP (20 & 27HP Only)
			60	A0000757081	Guide, Belt, Transaxle
			61	311161	Bolt, HWH, 5/16-18 X .75", Taptite, ZP
			62	A0000929783	Hanger, Exhaust, 5.31" (20 & 27HP Only)

\* Items Not Applicable to the PRO 26 (10.5 HP MODEL)

# Schematic – Drivetrain Assembly

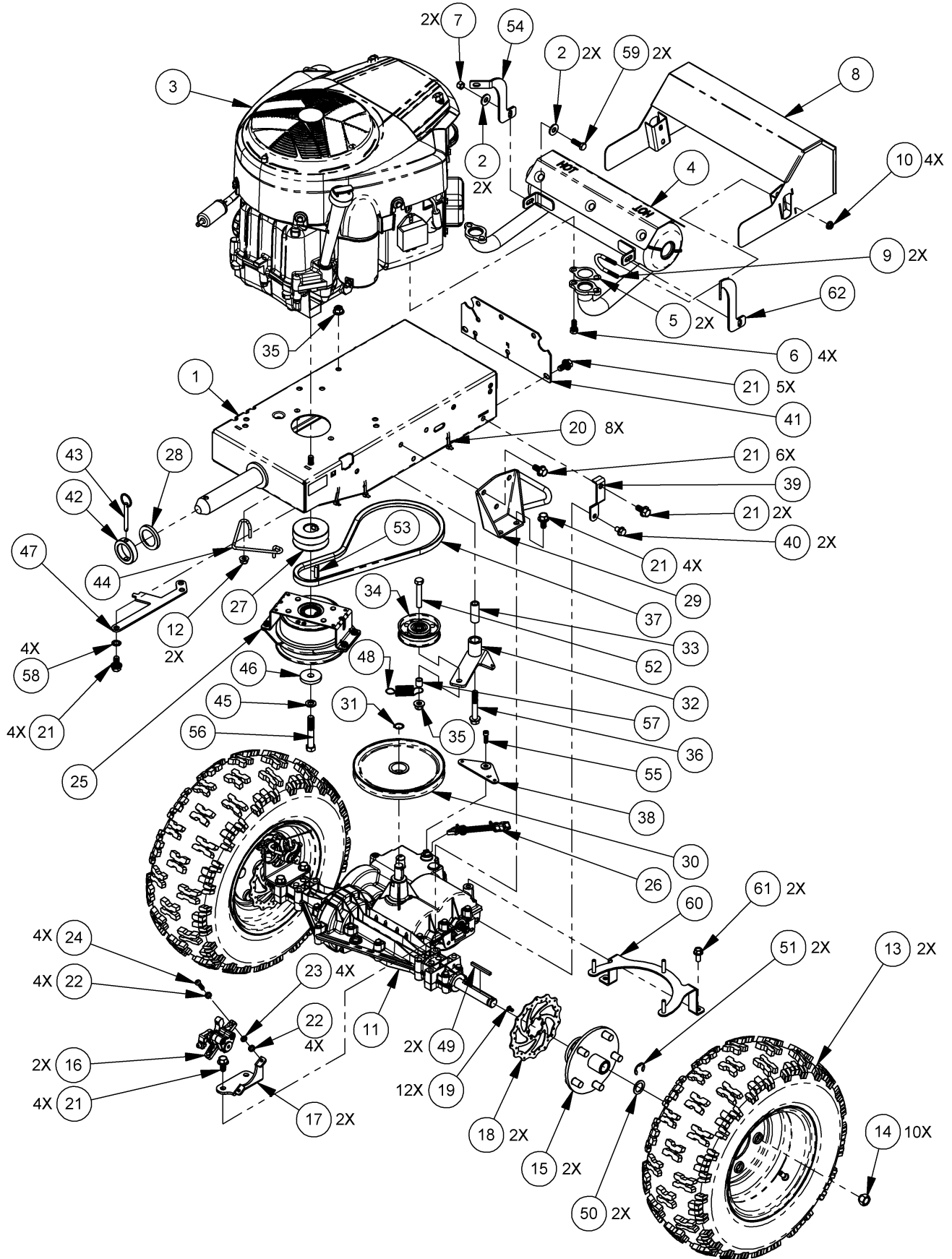

## Parts List – Brush Deck Assembly

**Note:** Part numbers listed are available through DR Power Equipment.

Ref#	Part#	Description	Ref#	Part#	Description
1	333321	Nut, Nylon Lock, Flanged, 5/16-18	22	164451	Pulley, V, 8.5" OD 5I or B Belt
2	109131	Bolt, Carr, 5/16-18 X 1.5", ZP	23	352881	Knob, 2.5", Stud, 3/8-16 X 3/4"
3	352811	Bolt, Hex, Flange, Tri Lobe, 3/8-16 X 3/4", GR5 ZP	24	352911	Bracket, Deck, Stiffener, Right
4	G064101	Nut, Hex, Fl Whiz, 3/8-16 (30" and 34" Models)	25	352921	Bracket, Deck, Stiffener, Left
5	344251	Brush Bar (26" Model)	26	150721	Bushing 1.385" ID X 1.629" OD X 1.50" L
	394671	Brush Bar (34" Model)	27	353011	Bolt, Carriage, 1/2-13 X 2", GR5, ZP
	394741	Brush Bar (30" Model)	28	345171	Bolt, Hex, Flange, 3/8-16 X 3.5", FT
6	364181	Skirt, Front (26" Model)	29	119141	Key, Square, 3/16 X .75"
	364201	Skirt, Front (34" Model)	30	151271	Pulley, Flat Idler, 4"
	364191	Skirt, Front (30" Model)	31	363391	Guard, Belt, AT4 w/ Labels
7	363401	Deck, 26" AT4 w/ Labels (26" Model)	32	A0000166145	Label, DR Logo, 4"
	10000032668	Deck, 34" AT4 w/ Labels, (34" Model)	33	229101	Nut, Finish, 1/2-13, GR5, ZP
	10000032706	Deck, 30" AT4 w/ Labels, (30" Model)	34	333321	Nut, Nylon Lock, Flanged, 5/16-18 (34" Model)
8	136491	Label, Danger, Blade	35	366161	Strap, Skirt, Mounting (26" Model)
9	136491	Label, Danger, Blade (34" Model)		366141	Strap, Skirt, Mounting (34" Model)
10	100481	Blade, 26", Air Tip (26" Model)		366151	Strap, Skirt, Mounting (30" Model)
	160891	Blade, 30", Air Tip (30" Model)	36	364171	Guard, Debris, Deck
	352961	Blade, 34", Air Tip (34" Model)	37	350511	Spacer, Idler
11	344261	Pivot, Deck, Bracket	38	350331	Bolt, Carr, 5/16-18 X 1.75", GR5, ZP
12	344381	Spindle, Assembly	39	394711	Baffle, 34" (34" Model)
13	352851	Belt, Brush Deck, BK56, 5/8" X 58.8"	40	394701	Guard, Anti-Wrap (30" and 34" Models)
14	101771	Washer, Blade	41	352811	Bolt, Hex, Flange, Tri Lobe, 3/8-16 X 3/4", GR5, ZP (26" Model)
15	A0002459381	Nut, Nylon Lock, 5/8-18, GR5, ZP		344071	Bolt, Hex, Flange, 3/8-16 X 1.5" GR5, ZP (30" and 34" Models)
16	A0000253515	Idler Arm, Brush Deck	42	350231	Bolt, Hex, Flange, 5/16-18 X .75"
17	333331	Nut, Nylon Lock, Flanged, 3/8-16	<b>Not Shown:</b>		
18	150941	Spring E .750" OD X .112" Wire	A0000253559	Plate, Stud, Rear Guard (26" Model)	
19	351431	Bushing, Idler, Brush Deck	353161	Guard, Deck, Rear, Rubber (26" Model)	
20	333481	Bolt, Hex, Flange, 3/8-16 X 2.5"			
21	A0000332299	Grease Fitting, 1/4-28, Straight			

**Schematic – Brush Deck Assembly**

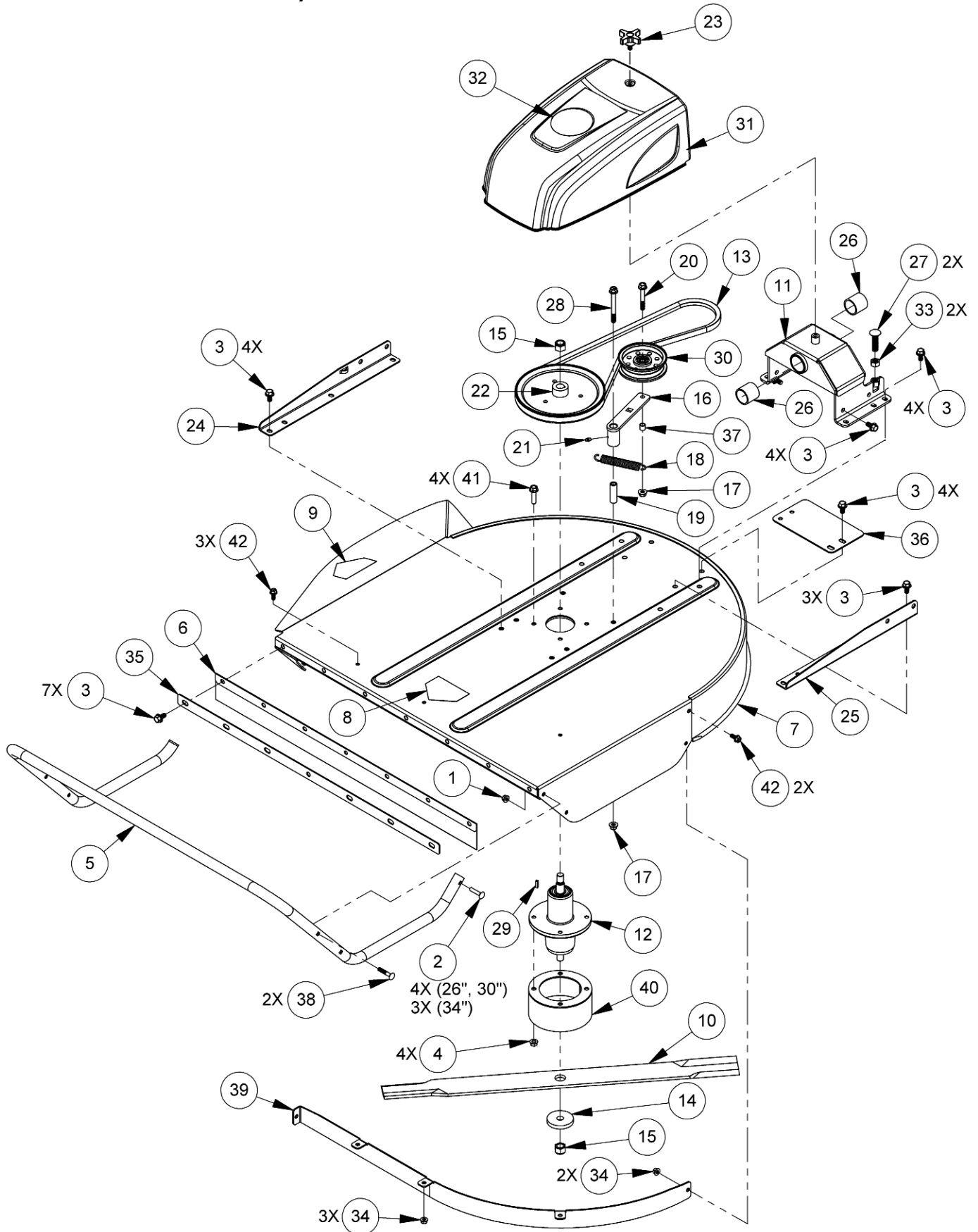

## Wiring Diagram –Electric Start

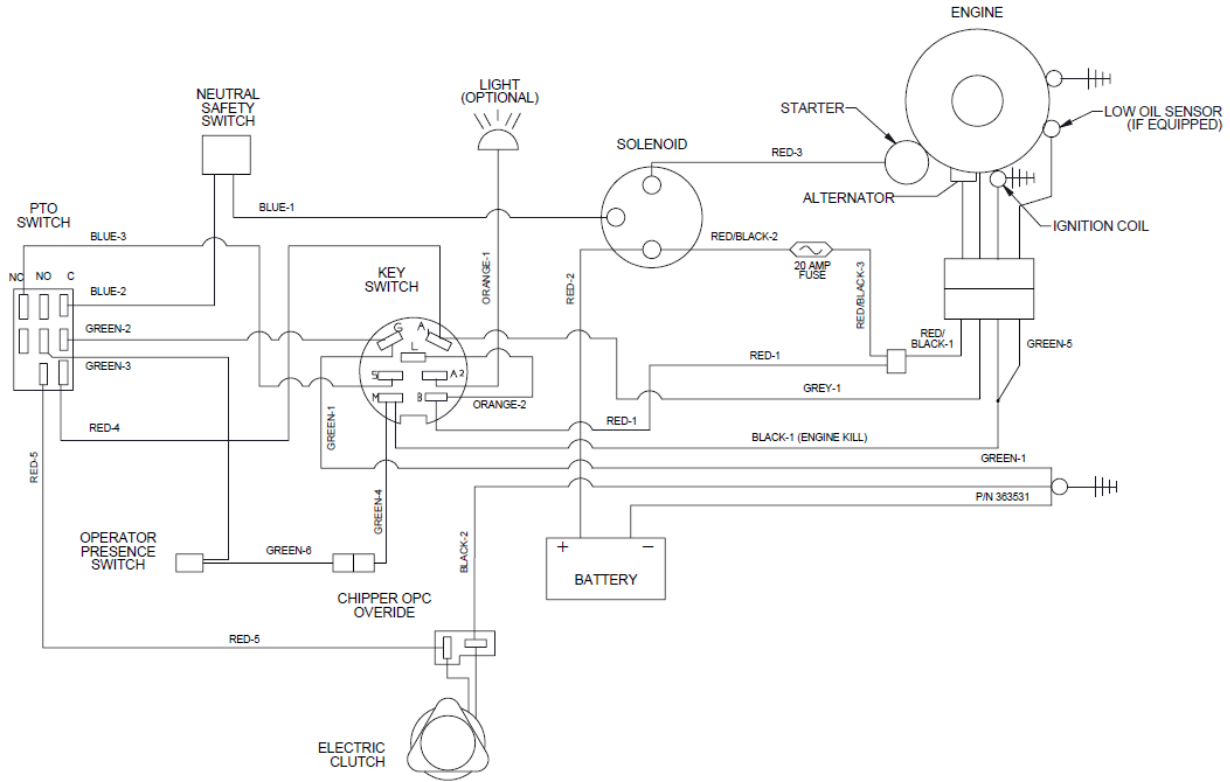

## Wiring Diagram –Manual Start

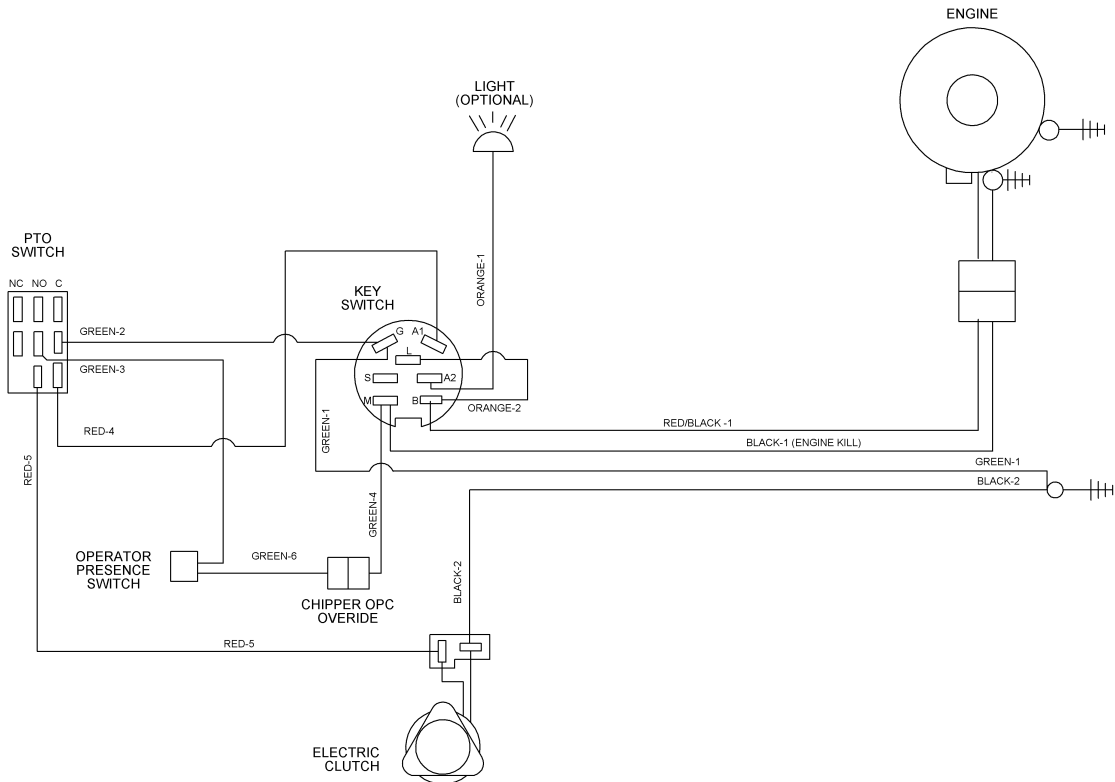

**Notes:**

**DR<sup>®</sup>** FIELD and BRUSH MOWER



## 2-Year Limited Warranty

### Terms and Conditions

The **DR<sup>®</sup>** FIELD and BRUSH MOWER is warranted for two (2) years against defects in materials or workmanship when put to ordinary and normal consumer use; ninety (90) days for any other use.

For the purposes of all the above warranties, "ordinary and normal consumer use" refers to non-commercial residential use and does not include misuse, accidents or damage due to inadequate maintenance.

DR Power Equipment certifies that the **DR<sup>®</sup>** FIELD and BRUSH MOWER is fit for ordinary purposes for which a product of this type is used. DR Power Equipment however, limits the implied warranties of merchantability and fitness in duration to a period of two (2) years in consumer use, ninety (90) days for any other use except all emission related components. DR Power Equipment limits the implied warranties of merchantability and fitness in duration to a period of two (2) years for all emissions related components. The Engine manufacturer warrants the Engine separately.

The 2-Year Limited Warranty on the **DR<sup>®</sup>** FIELD and BRUSH MOWER starts on the date the machine ships from our factory. The 2-Year Limited Warranty is applicable only to the original owner.

The warranty holder is responsible for the performance of the required maintenance as defined by the manufacturer's owner's manuals. The warranty holder is responsible for replacement of normally wearing parts such as the Drive Belts, Blade, Filters, Spark Plug(s), Brake Components and Battery. Accessories to the machine are not covered by this warranty.

During the warranty period, the warranty holder is responsible for the machine transportation charges, if required. During the warranty period, warranty parts will be shipped by standard method at no charge to the warranty holder. Expedited shipping of warranty parts is the responsibility of the warranty holder.

SOME STATES DO NOT ALLOW LIMITATIONS ON THE LENGTH OF IMPLIED WARRANTIES, SO THE ABOVE LIMITATIONS MAY NOT APPLY TO YOU.

DR Power Equipment shall not be liable under any circumstances for any **incidental or consequential damages or expenses** of any kind, including, but not limited to, cost of equipment rentals, loss of profit, or cost of hiring services to perform tasks normally performed by the **DR<sup>®</sup>** FIELD and BRUSH MOWER.

SOME STATES DO NOT ALLOW THE EXCLUSION OR LIMITATION OF INCIDENTAL OR CONSEQUENTIAL DAMAGES, SO THE ABOVE LIMITATIONS MAY NOT APPLY TO YOU.

THIS WARRANTY GIVES YOU SPECIFIC LEGAL RIGHTS, AND YOU ALSO HAVE OTHER RIGHTS, WHICH VARY FROM STATE TO STATE.

## Daily Checklist for the DR FIELD and BRUSH MOWER

To help maintain your DR FIELD and BRUSH MOWER for optimum performance, we recommend you follow this checklist each time you use your machine.

---

### WARNING

Before performing any maintenance procedure or inspection, stop the engine, wait five (5) minutes to allow all parts to cool. Disconnect the spark plug wire(s), keeping it away from the spark plug(s).

---

- Check the engine oil level.
- Check the gas Level
- Check the general condition of the Mower, e.g.; nuts, bolts, welds, etc.
- Check Tire Pressure
- Check belts for wear, proper alignment and tension.
- Check the Blade for tightness, nicks and wear. Remove any wrapped weeds and grass from the Blade Bearing Housing to prevent buildup.
- Check that the engine air cooling system is clean of debris.

---

### WARNING

Before performing any maintenance procedure or inspection, stop the engine, wait five (5) minutes to allow all parts to cool and disconnect Spark Plug(s)

---

## End of Season and Storage

**Note:** Please refer to the Engine Owner's Manual for engine-specific procedures.

- Change the oil (and oil filter, if applicable). For winter use, use SAE 5W – 30 HD.
- Remove the Spark Plug(s) and pour about 1 ounce of motor oil into the Cylinder hole. Replace the Plug(s) and crank the Engine a couple of times. This will coat the piston(s) and seat the valves to prevent moisture buildup.
- Clean/replace the Air Filters.
- Clean dirt and debris from the Cylinder Head Cooling Fins, Blower Housing, Debris Screen, and Muffler area of the Engine.
- If your Engine has a Fuel Filter, replace it.
- If your DR FIELD and BRUSH MOWER will be idle for more than 30 days, we recommend using a gas stabilizer. This will prevent sediment from gumming up the Carburetor. If there is dirt or moisture in the gas or Tank, remove it by draining the Tank. Completely fill the Tank with fresh, unleaded gas and add the appropriate amount of stabilizer or gasoline additive. Run the Engine for a short time to allow the additive to circulate. Close the Fuel Shut-Off Valve, if your machine is equipped with one, to prevent Carburetor overflow and leakage.
- Store the Battery in a dry area that will not freeze. If you will not use the machine over a long period, charge the Battery every four to six weeks.
- Remove any wrapped weeds from the Blade Bearing Housing. Clean grass and debris from the top and underneath the Mower Deck with a stiff brush.
- Check the Blade for nicks and wear. Remove the Blade and sharpen, or have it professionally sharpened if needed.
- Perform the lubrication as outlined starting on page 19.

**Note:** For winter use, please refer to the attachment instructions.



---

800 HINESBURG ROAD, SOUTH BURLINGTON, VERMONT 05403