

# DR<sup>®</sup> 48" LANDSCAPE RAKE



## SAFETY & OPERATING INSTRUCTIONS



Serial No. \_\_\_\_\_

Order No. \_\_\_\_\_

**Original Language**

DR Power Equipment  
Toll-free phone: 1-800-DR-OWNER (376-9637)  
Fax: 1-802-877-1213  
Website: [www.DRpower.com](http://www.DRpower.com)

### **! WARNING**

Read and understand this manual and all instructions before operating the DR 48" LANDSCAPE RAKE.

## Table of Contents

Chapter 1: General Safety Rules.....	3
Chapter 2: Setting Up the DR 48" LANDSCAPE RAKE .....	5
Chapter 3: Operating The DR 48" LANDSCAPE RAKE .....	8
Chapter 4: Maintaining The DR 48" LANDSCAPE RAKE .....	10
Chapter 5: Parts Lists, Schematic Diagrams and Warranty.....	12

### *Conventions used in this manual*

---

#### **WARNING**

This indicates a hazardous situation which, if not avoided, **could** result in death or serious injury.

---

#### **CAUTION**

This indicates a hazardous situation which, if not avoided, **could** result in minor or moderate injury.

---

#### **NOTICE**

This information is important in the proper use of your machine. Failure to follow this instruction could result in damage to your machine or property.

---

### *Serial Number and Order Number*

A Serial Number is used to identify your machine and is located on the Serial Number Label on your machine. An Order Number is used to check and maintain your order history and is located on the upper left portion of your packing slip. For your convenience and ready reference, enter the Serial Number and Order Number in the space provided on the front cover of this manual.

### *Additional Information and Potential Changes*

DR Power Equipment reserves the right to discontinue, change, and improve its products at any time without notice or obligation to the purchaser. The descriptions and specifications contained in this manual were in effect at printing. Equipment described within this manual may be optional. Some illustrations may not be applicable to your machine.

## Chapter 1: General Safety Rules

---

### **WARNING**

Read this safety & operating Instructions manual before you use the DR 48" LANDSCAPE RAKE. Become familiar with the operation and service recommendations to ensure the best performance from your machine. If you have any questions or need assistance, please contact us at [www.DRpower.com](http://www.DRpower.com) or call toll-free 1-800-DR-OWNER (376-9637) and one of our Technical Support Representatives will be happy to help you.

---

### **Labels**

Your DR 48" LANDSCAPE RAKE carries prominent labels as reminders for its proper and safe use. Shown below are copies of all the Safety and Information labels that appear on the equipment. Take a moment to study them and make a note of their location on your LANDSCAPE RAKE as you set up and before you operate the unit. Replace damaged or missing safety and information labels immediately.

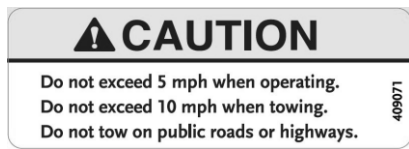

#40907



#25044

### **Protecting Yourself and Those Around You**

---

#### **WARNING**

Always take the following precautions when operating this Landscape Rake:

- Always wear protective goggles or safety glasses with side shields while operating to protect your eyes from possible thrown bits of dirt or gravel.
  - Wear shoes with non-slip treads when using your DR Landscape Rake. If you have safety shoes, we recommend wearing them. Do not use the Landscape Rake while barefoot or wearing open sandals.
  - Wear a helmet when operating an ATV.
- 

### **Safety for Children and Pets**

---

#### **WARNING**

Tragic accidents can occur if the operator is not alert to the presence of children and pets. **Never** assume that children or pets will remain where you last saw them.

- Keep children out of the working area and under the watchful care of a responsible adult.
  - Be alert, stop and turn the tow vehicle off if children or pets enter the work area.
  - Never allow children to operate the DR Landscape Rake.
  - Never allow children or pets to ride on the tow vehicle or the DR Landscape Rake.
-

## Operating the DR 48" LANDSCAPE RAKE Safely

---

### **WARNING**

You must operate the Landscape Rake safely. Unsafe operation can create a number of hazards for you. Always take the following precautions when using this Landscape Rake:

- Read, understand, and follow all instructions in this manual. Be thoroughly familiar with the controls and the proper use of your Landscape Rake before using.
  - Thoroughly inspect the area where your Landscape Rake will be used, and remove all stones, sticks, wire, pet supplies, or lawn toys, and any other foreign objects that you could run over. Also, note the location of stumps, and other possible hazards that you should avoid during operation.
  - Watch for traffic when operating near roadways. Pay extra attention when operating near public roadways.
  - Be aware of your surroundings when operating the DR Landscape Rake, e.g. ditches, culverts, drop-offs, and hills.
  - Never allow people who are unfamiliar with these instructions to use the DR Landscape Rake.
  - To be safe, do not operate the Landscape Rake near small children or pets, and never allow children to operate the Landscape Rake. Stop the operation when another person or pet approaches.
  - Do not allow people to ride on the Landscape Rake.
  - If you have to stop to remove any debris from the Landscape Rake, always shut off the tow vehicle's engine and set the parking brake.
  - Do not, under any conditions, remove, bend, cut, fit, weld, or otherwise alter standard parts on the DR Landscape Rake. Modifications to your machine could cause personal injuries and will void your warranty.
  - While using the DR Landscape Rake, don't hurry or take things for granted.
  - Do not operate the Landscape Rake when under the influence of alcohol or medication.
  - Use the DR Landscape Rake only in daylight or good artificial light.
- 

### **CAUTION**

The DR Landscape Rake must be operated safely to prevent or minimize the risk of minor or moderate injury. Unsafe operation can create a number of hazards for you. Always take the following precautions when operating this Landscape Rake:

- Keep in mind that the operator or user is responsible for accidents or hazards occurring to other people, their property, and themselves.
  - Do not use the DR Landscape Rake to drag, tow, or carry items.
  - Never operate the DR Landscape Rake with a truck (2wd or 4wd); doing so will void the DR Landscape Rake warranty.
  - Never leave the DR Landscape Rake unattended. If you leave the area, shut off the tow vehicle, and remove the key.
  - Keep all nuts and bolts tight and keep the equipment and attachments in good operating condition.
  - Use only manufacturer-recommended replacement parts.
  - Do not use the DR Landscape Rake in a manner not in accordance with these instructions.
- 

## California Proposition 65

### **WARNING**

California Proposition 65:

- This product contains or emits chemicals known to the State of California to cause cancer, birth defects, and other reproductive harm.
- 

## A Note to All Users

No list of warnings and cautions can be all-inclusive. If situations occur that are not covered by this manual, the operator must apply common sense and operate this DR LANDSCAPE RAKE in a safe manner. Contact us at [www.DRpower.com](http://www.DRpower.com) or call 1-800-DR-OWNER (376-9637) for assistance.

## Chapter 2: Setting Up the DR 48" LANDSCAPE RAKE

It may be helpful to familiarize yourself with the features of your DR 48" LANDSCAPE RAKE as shown in Figure 2 before beginning these procedures. If you have any questions at all, please feel free to contact us at [www.DRpower.com](http://www.DRpower.com).

### DR LANDSCAPE RAKE Features

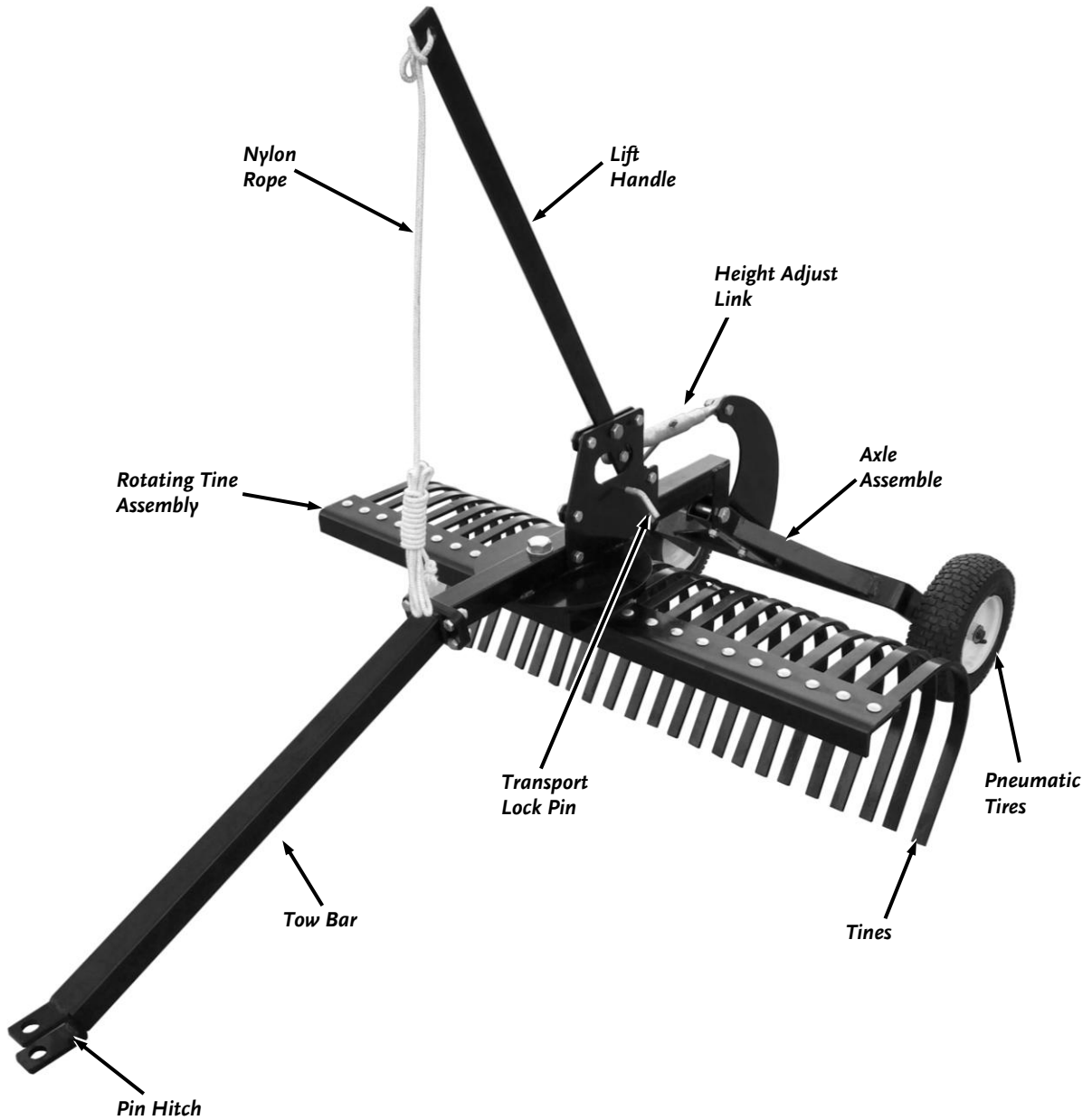

Figure 1

# Specifications

Tine QTY	24
Wheels	Pneumatic, 12" Diameter
Working Width	48"
Hitch Type	Pin

## Assembling the DR 48" Landscape Rake

### Parts Supplied in Hardware Bag (Figure 2):

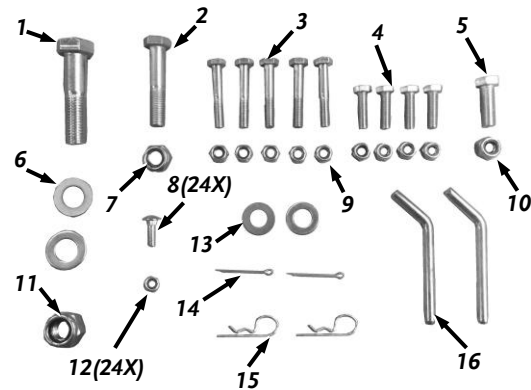

Figure 2

Item #	Part #	Description	Qty
1	40945	Bolt, Hex, M24 X 100	1
2	40971	Bolt, Hex, M18 X 90	1
3	40955	Bolt, Hex, M12 X 70	5
4	40942	Bolt, Hex, M12 X 40	4
5	40961	Bolt, Hex, M16 X 45	1
6	40946	Washer, Flat, M24	2
7	40972	Nut, Nylon Lock, M18	1
8	40948	Bolt, Carriage, M10 X 30	24
9	40943	Nut, Nylon Lock, M12	9
10	40962	Nut, Nylon Lock, M16	1
11	40947	Nut, Nylon Lock, M24	1
12	40952	Nut, Nylon Lock, M10	24
13	40976	Washer, Flat, M20	2
14	40977	Pin, Cotter, 4 X 50	2
15	40954	Pin, Retaining	2
16	40953	Pin, Hitch	2

Compare the contents of the Hardware Bag with the "Parts Supplied" list above. If you have any questions please contact us at [www.DRpower.com](http://www.DRpower.com) or call 1-800-DR-OWNER (376-9637) for assistance.

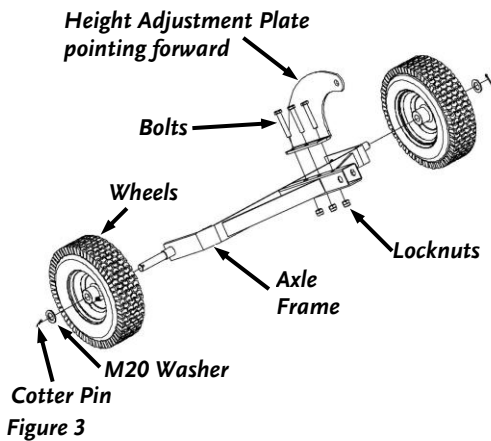

Figure 3

### Tools Needed:

- 17mm Wrench
- 18mm Wrench
- Two 19mm Wrenches
- Two 24mm Wrenches
- Two 27mm Wrenches
- Two 36mm Wrenches

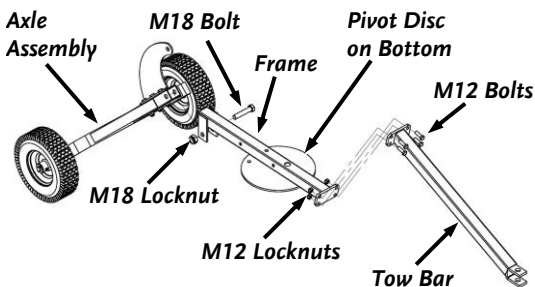

Figure 4

1. Install the Wheels to the Axle Frame, with the Valve Stems facing out, using the M20 Flat Washers and Cotter pins (Figure 3).
2. Install the Height Adjustment Plate onto the Axle Frame so that it is pointing forward (away from the Wheels) using three M12 X 70 Hex Bolts and Locknuts. Tighten the hardware using two 19mm Wrenches.
3. Position the Frame so that the Pivot Disc is on the Bottom (Figure 4). Install the Tow Bar to the Frame so that it is angled down using four M12 X 40 Bolts and Locknuts. Tighten the hardware using two 19 mm Wrenches.
4. Install the Axle Assembly to the rear of the Frame using the M18 X 90 Bolt and Locknut. Use two 27mm Wrenches to tighten the Hardware. Do not over tighten; the Axle Assembly should be able to rotate freely.

- Attach the Lift Handle Support to the left side of Frame using two M12 X 70 Bolts and Locknuts (**Figure 5**). Tighten the Hardware using two 19mm Wrenches.
- Insert the Lift Handle between the plates on the Lift Handle Support. Insert a M16 X 45 Bolt through the Lift Handle Support and the Top Hole of the Lift Handle and secure with a M16 Locknut. Use two 24mm Wrenches to tighten the hardware. Do not over tighten; the Lift Handle should be able to rotate freely.

**Note:** The Hardware for the next step is loosely installed on the Height Adjust Link.

- Attach one side of the Height Adjust link to the Lift Handle and attach the other side to the Height Adjustment Plate using the two Hex Bolts, two Bushings, two Small Washers, and two Hex Lock Nuts (**Figure 6**). Tighten the Hardware using an 18mm Wrench on the bolt and a 19mm Wrench on the Locknut.
- Attach the twenty-four Tines to the bottom of the Tine Frame using the four Tine Pressure Plates, twenty-four Carriage Bolts and twenty-four M10 Locknuts (**Figure 7**). Ensure that the Tine Pressure Plates are installed so that they prevent the tines from rotating when tightened. Tighten the Hardware using a 17mm Wrench.

**Note:** If the Tines can rotate after tightening, the Tine Pressure Plates are installed upside down.

- Connect the Tine Assembly to the Frame Assembly using the M24 X 100 Bolt, Washers, and Locknut (**Figure 8**). Tighten the Hardware using two 36mm Wrenches. Do not over tighten; the Tine Assembly should be able to rotate freely.
- Attach the Nylon Rope to the Lift Handle.
- Insert one Hitch Pin in the Lift handle support to lock the Lift Handle in the Transport position. Insert the other Hitch Pin down through the Frame and into the Tine Assembly to lock it in place. Secure both Hitch Pins with the Retaining Pins.

## Checking the Tire Pressure

### Tools and Supplies Needed:

- Tire Pressure Gauge
- Air Compressor

- Remove the Valve Stem Protective Cap and check the tire pressure with a Tire Pressure Gauge.
- Check what the manufacturers recommended pressure is that is stamped on the side of the Tire.
- If the pressure is too low, add air through the Valve Stem with an air hose.
- Replace the Valve Stem Protective Cap when finished.
- Repeat for both Wheels.

## WARNING

Do not over inflate the tires. Inflate to the manufacturers recommended pressure found on the tires.

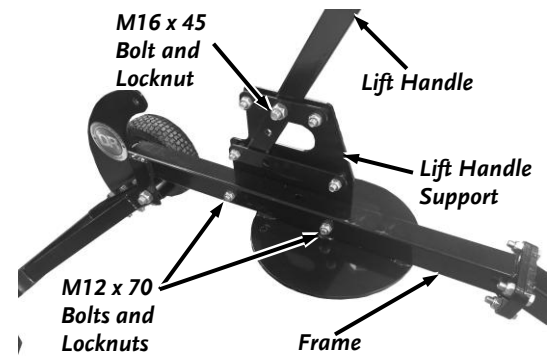

Figure 5

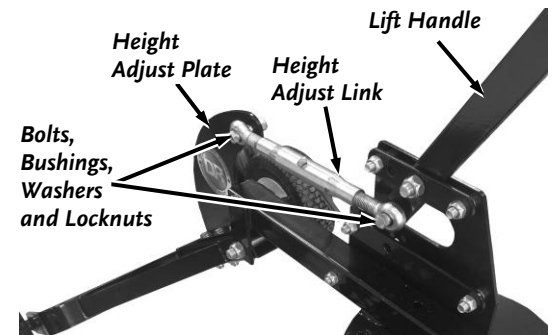

Figure 6

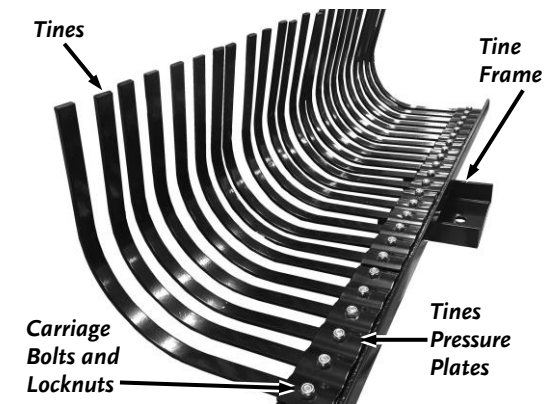

Figure 7

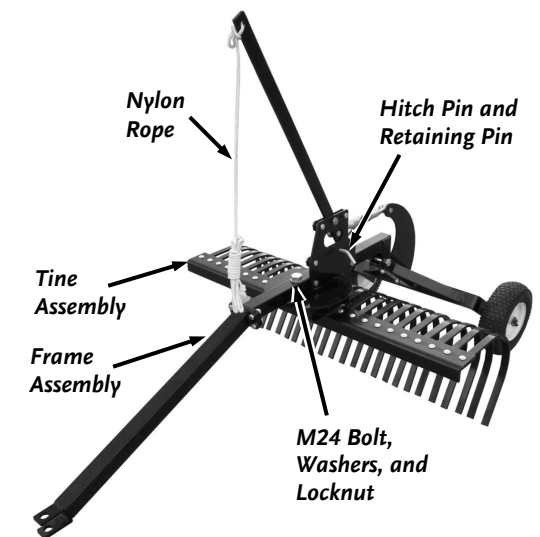

Figure 8

## Chapter 3: Operating The DR 48" LANDSCAPE RAKE

It may be helpful to better familiarize yourself with the features of your Landscape Rake by reviewing **Figure 1** in Chapter 2 before beginning the steps outlined in this chapter.

### Operating Safety

#### **! WARNING**

- Never allow anyone to operate the DR Landscape Rake without first reading and understanding all instructions in this manual. Be thoroughly familiar with the controls and the proper use of your Landscape Rake before using.
- Never let people ride on the Landscape Rake.
- Always check for objects in the Landscape Rake's path before moving.

### Operating Parameters

The DR Landscape Rake can be used with a **Garden Tractor/Lawn Tractor, ATV, UTV, or Utility Tractor**. NEVER operate the DR LANDSCAPE RAKE with a Car or Truck (2WD or 4WD). Use of these vehicles can be hazardous and will void the DR LANDSCAPE RAKE Warranty.

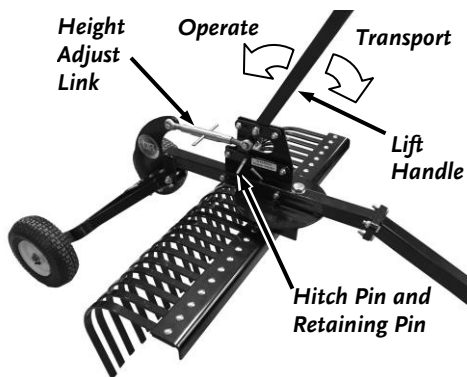

Figure 9

#### Transport Position

The Landscape Rake is in the Transport position when the weight of the machine is supported by the wheels and the tines are lifted from the ground. This allows the Landscape Rake to be transported to and from the working area without the Tines touching the ground. To position the Landscape Rake in the transport position, pull forward on the Nylon Rope/Lift Handle (**Figure 9**). To lock the machine in the Transport Position, pull forward on the Lift Handle and Insert the Hitch Pin and Retaining Pin into the Lift Handle Support.

#### Operating Position

The Landscape Rake is in the operating position when the wheels are lifted and the Tines are on the ground. This allows the tines to scrape, grade, and resurface the soil when towed behind a tow vehicle. To position the Landscape Rake in the operating position, pull forward on the Lift Handle and remove the Hitch Pin and Retaining pin, then slowly release the Lift Handle so that the tines are lowered to the ground (**Figure 9**).

#### **! WARNING**

- Do not exceed 5MPH when using the DR Landscape Rake in the Operating Position.
- Do not exceed 10MPH when using the DR Landscape Rake in the Transport Position.

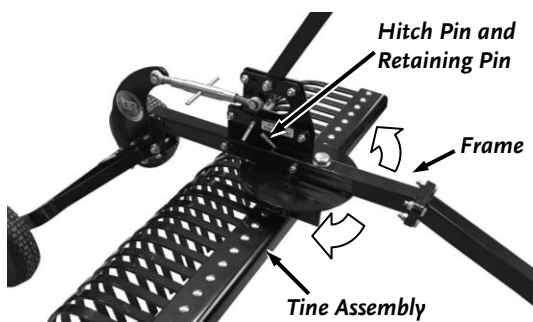

Figure 10

#### Adjusting the Height

Adjust the Height of the Transport/Operating Positions by turning the Height Adjust Link (**Figure 9**).

#### Adjusting the Rake Angle

While Locked in the Transport Position, Remove the Hitch Pin and Retaining Pin that Locks the Tine Assembly to the Frame (**Figure 10**). Rotate the Tine Assembly to the desired angle and replace the Hitch Pin and Retaining Pin.



## ***Attaching the DR Landscape Rake to the Tow Vehicle***

1. Stop the Tow Vehicle Engine and set the Parking Brake.
2. Lift the Tow Bar and position the Pin Hitch opening onto the Tow Vehicles Hitch Plate (**Figure 11**).
3. Align the hole in the center of the Hitch Plate with the holes in the Pin Hitch. Insert the Hitch Pin and secure it with the Hair Pin.

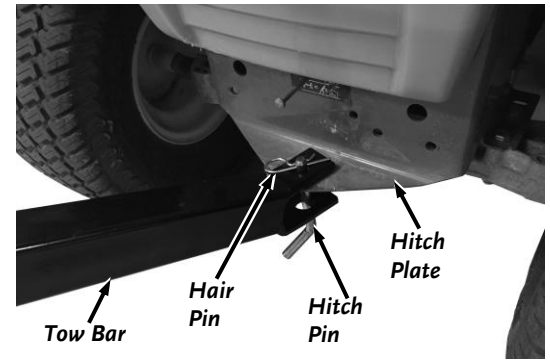

**Figure 11**

## Chapter 4: Maintaining The DR 48" LANDSCAPE RAKE

Regular maintenance is the way to ensure the best performance and long life of your machine. Please refer to this Chapter for maintenance intervals and procedures.

### **⚠ WARNING**

Before performing any maintenance, you must first shut off the tow vehicle, remove the key and set the parking brake.

### Regular Maintenance Checklist

PROCEDURE	BEFORE EACH USE
Check general equipment condition e.g., Nuts, Bolts, welds, etc.	▲
Hose down the DR LANDSCAPE RAKE	▲
Check the Tire Pressure	▲
Check condition of Tines	▲

### Cleaning the DR Landscape Rake

1. Use a Hose or Pressure Washer to clean the DR Landscape Rake to keep the Tines, Transport Wheels etc. clean and clear of debris.



Figure 10

### Checking the Tire Pressure

#### Tools and Supplies Needed:

- Tire Pressure Gauge
- Air Compressor

1. Remove the Valve Stem Protective Cap (**Figure 10**) and check the tire pressure with a Tire Pressure Gauge.
2. Check what the manufacturers recommended pressure is that is stamped on the side of the Tire.
3. If the pressure is too low, add air through the Valve Stem with an air hose.
4. Replace the Valve Stem Protective Cap when finished.
5. Repeat for both Wheels.

### **⚠ WARNING**

Do not over inflate the tires. Inflate to the manufacturers recommended pressure found on the tires.

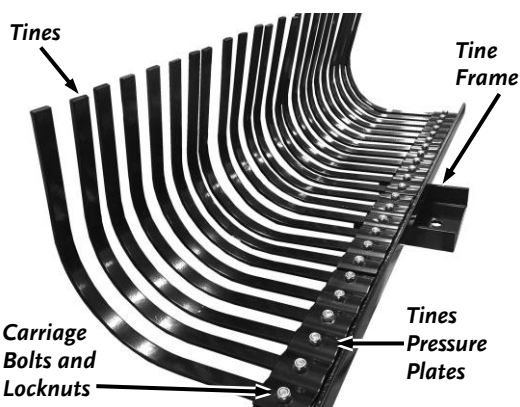

Figure 11

### Replacing the Tines

#### Tools Needed:

- 17mm Wrench

1. Use a 17mm Wrench to remove the Carriage Bolt and Locknut that secures the Tine (**Figure 11**). Slide the Tine out of the Tine Pressure Plate.
2. Slide the replacement Tine into the Tine Pressure Plate and re-secure with the Carriage Bolt and Locknut.
3. Repeat for all damaged or worn Tines.



## Chapter 5: Parts Lists, Schematic Diagrams and Warranty

---

### Parts List – LANDSCAPE RAKE ASSEMBLY

**Note:** Part numbers listed are available through DR Power Equipment.

Ref#	Part#	Description	Ref#	Part#	Description
1	40941	Tongue A	18	40958	Lift Handle Bracket #2
2	40942	Bolt, M12 x 40	19	40959	Lift Handle Bracket #1
3	40943	Locknut, M12	20	40960	Lift Handle
4	40944	Tongue B	21	40961	Bolt, M16 x 45
5	40945	Bolt, M24 x 100	22	40962	Locknut, M16
6	40946	Large Washer Ø24	23	40963	Bolt, M12 x 50
7	40947	Locknut, M24	24	40964	Bushing
8	40948	Bolt, Carriage, M10 x 30	25	40969	Height Adjustment Component
9	40949	Tine Assembly Support	26	40970	Small Washer, Ø12
10	40950	Tine	27	40971	Bolt, M18 x 90
11	40951	Tine Pressure Plate	28	40972	Locknut, M18
12	40952	Locknut, M10	29	40973	Height Adjustment Plate
13	40953	Pin, Hitch	30	40974	Axle Frame
14	40954	Pin, Retaining, Ø2.5	31	40975	12" Pneumatic Tire
15	40955	Bolt, M12 x 70	32	40976	Medium Washer, Ø20
16	40956	Lift Handle Support	33	40977	Cotter Pin, Ø4 x 50
17	40957	Bushing, Ø17.5 x Ø12.5 x 11.2mm	34	40978	Nylon Rope
<b>Not Shown</b>					
			40907		Label, Warning, Max Speed
			25044		Label, Warning, Pinch Point
			34140		Label, Branding, DR

**Schematic – Landscape Rake Assembly**

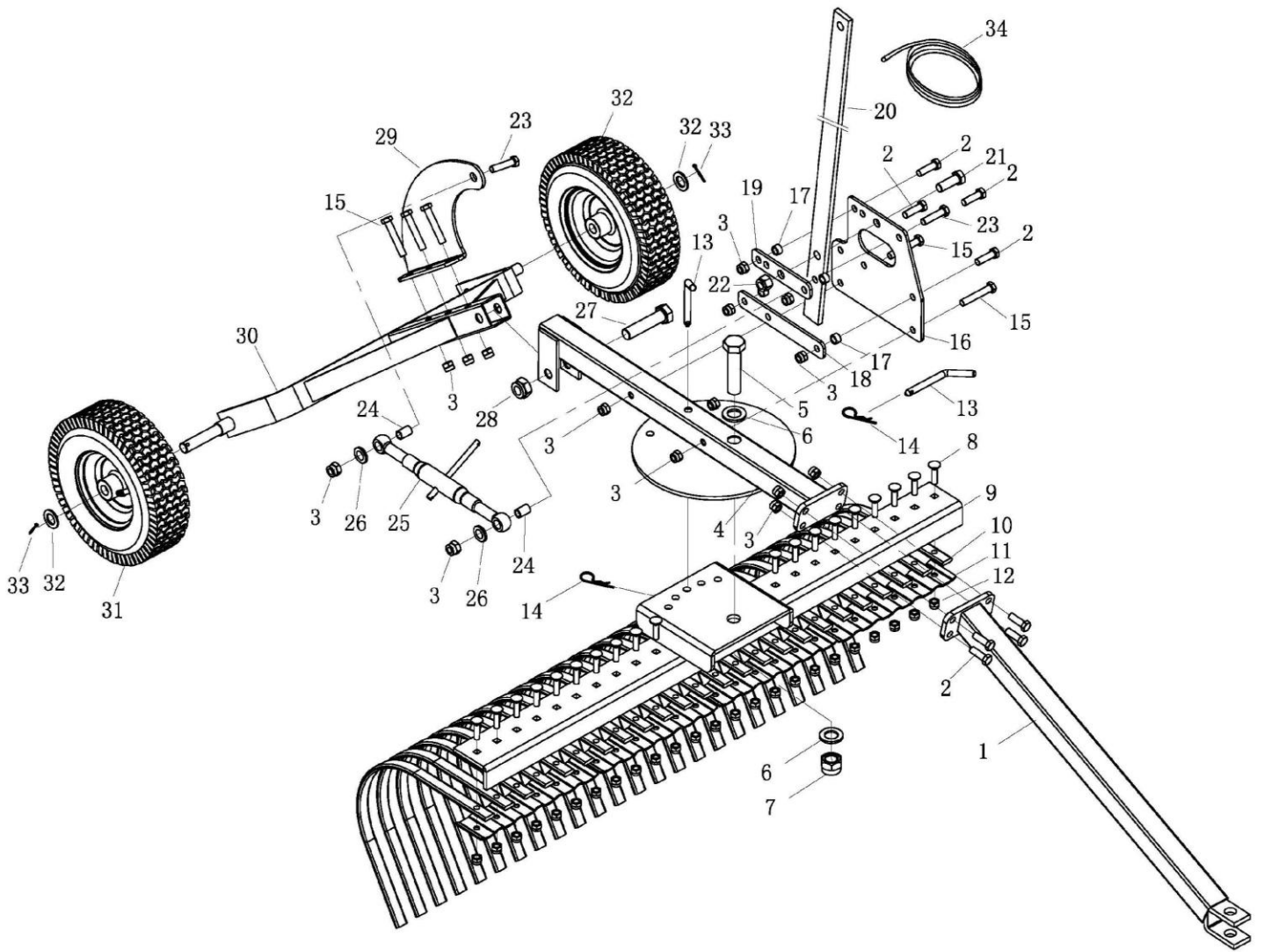

**Notes:**

# DR<sup>®</sup> 48" LANDSCAPE RAKE



## 2-Year Limited Warranty

### Terms and Conditions

The DR<sup>®</sup> LANDSCAPE RAKE is warranted for two (2) years against defects in materials or workmanship when put to ordinary and normal consumer use; ninety (90) days for any other use.

For the purposes of all the above warranties, "ordinary and normal consumer use" refers to non-commercial residential use and does not include misuse, accidents or damage due to inadequate maintenance.

DR Power Equipment certifies that the DR<sup>®</sup> LANDSCAPE RAKE is fit for ordinary purposes for which a product of this type is used. DR Power Equipment however, limits the implied warranties of merchantability and fitness in duration to a period of two (2) years in consumer use, ninety (90) days for any other use.

The 2-Year Limited Warranty on the DR<sup>®</sup> LANDSCAPE RAKE starts on the date the machine ships from our factory. The 2-Year Limited Warranty is applicable only to the original owner.

The warranty holder is responsible for the performance of the required maintenance as defined by the manufacturer's owner's manuals. The warranty holder is responsible for replacement of normally wearing parts such as the Tines, and Pneumatic Tires. Accessories to the machine are not covered by this warranty.

During the warranty period, the warranty holder is responsible for the machine transportation charges, if required. During the warranty period, warranty parts will be shipped by standard method at no charge to the warranty holder. Expedited shipping of warranty parts is the responsibility of the warranty holder.

SOME STATES DO NOT ALLOW LIMITATIONS ON THE LENGTH OF IMPLIED WARRANTIES, SO THE ABOVE LIMITATIONS MAY NOT APPLY TO YOU.

DR Power Equipment shall not be liable under any circumstances for any **incidental or consequential damages or expenses** of any kind, including, but not limited to, cost of equipment rentals, loss of profit, or cost of hiring services to perform tasks normally performed by the DR<sup>®</sup> LANDSCAPE RAKE.

SOME STATES DO NOT ALLOW THE EXCLUSION OR LIMITATION OF INCIDENTAL OR CONSEQUENTIAL DAMAGES, SO THE ABOVE LIMITATIONS MAY NOT APPLY TO YOU.

THIS WARRANTY GIVES YOU SPECIFIC LEGAL RIGHTS, AND YOU ALSO HAVE OTHER RIGHTS, WHICH VARY FROM STATE TO STATE.

## ***Daily Checklist for the DR 48" LANDSCAPE RAKE***

To help maintain your DR 48" LANDSCAPE RAKE for optimum performance, we recommend you follow this checklist each time you use your LANDSCAPE RAKE

---

### **⚠ WARNING**

Before performing any maintenance, you must first shut off the tow vehicle, remove the key and set the parking brake.

---

- [ ] **HARDWARE:** Check all nuts and bolts to be sure that the components are secure.
- [ ] **FRAME:** Check all welds to be sure that the frame is intact and secure.
- [ ] **CLEAN:** Make sure the Tines and the Frame are clean and free of debris.

### ***End of Season and Storage***

---

### **⚠ WARNING**

Before performing any maintenance, you must first shut off the tow vehicle, remove the key and set the parking brake.

---

- Hose down the DR LANDSCAPE RAKE to clean it of debris.
- Wipe down the DR LANDSCAPE RAKE to remove any moisture and dirt that may have accumulated.
- If possible, store the Landscape Rake in a dry, protected place. If it is necessary to store the Landscape Rake outside, cover it with a protective material.



---

**75 MEIGS ROAD, P.O. BOX 25, VERGENNES, VERMONT 05491**