

# DR<sup>®</sup> CHIPPER/SHREDDER

## SAFETY & OPERATING INSTRUCTIONS



Serial No. \_\_\_\_\_

Order No. \_\_\_\_\_

**Original Language**

DR Power Equipment  
Toll-free phone: 1-800-DR-OWNER (376-9637)  
Fax: 1-802-877-1213  
Website: [www.DRpower.com](http://www.DRpower.com)

### **! WARNING**

Read and understand this manual and all instructions before operating the DR CHIPPER/SHREDDER.

## Table of Contents

Chapter 1: General Safety Rules.....	3
Chapter 2: Setting Up The DR CHIPPER/SHREDDER.....	7
Chapter 3: Operating The DR CHIPPER/SHREDDER .....	10
Chapter 4: Maintaining The DR CHIPPER/SHREDDER .....	14
Chapter 5: Troubleshooting .....	21
Chapter 6: Parts Lists and Schematic Diagrams.....	24

### *Conventions used in this manual*

---

#### **DANGER**

This indicates a hazardous situation, which, if not followed, will result in death or serious injury.

---

#### **WARNING**

This indicates a hazardous situation, which, if not avoided, could result in death or serious injury.

---

#### **CAUTION**

This indicates a hazardous situation, which, if not avoided, could result in minor or moderate injury.

---

#### **NOTICE**

This information is important in the proper use of your machine. Failure to follow this instruction could result in damage to your machine or property.

---

### *Serial Number and Order Number*

A Serial Number is used to identify your machine and is located on the Serial Number Label on your machine. An Order Number is used to check and maintain your order history and is located on the upper left portion of your packing slip. For your convenience and ready reference, enter the Serial Number and Order Number in the space provided on the front cover of this manual.

### *Additional Information and Potential Changes*

DR Power Equipment reserves the right to discontinue, change, and improve its products at any time without notice or obligation to the purchaser. The descriptions and specifications contained in this manual were in effect at printing. Equipment described within this manual may be optional. Some illustrations may not be applicable to your machine.

## Chapter 1: General Safety Rules

### **WARNING**

Read this Safety & Operating Instructions Manual before you use the DR CHIPPER/SHREDDER. Become familiar with the operation and service recommendations to ensure the best performance from your machine. If you have any questions or need assistance, please contact us at [www.DRpower.com](http://www.DRpower.com) or call Toll-Free 1-800-DR-OWNER (376-9637) and one of our Technical Support Representatives will be happy to help you.

### Labels

Your DR CHIPPER/SHREDDER carries prominent labels as reminders for its proper and safe use. Shown below are copies of all the Safety and Information labels that appear on the equipment. Take a moment to study them and make a note of their location on your CHIPPER/SHREDDER as you set up and before you operate the unit. Replace damaged or missing Safety and Information labels immediately.



#242321

WARNING: Check Oil Before Starting Engine

#137581

DR POWER EQUIPMENT  
75 Meigs Road, Vergennes, VT 05491  
1-800-DR-OWNER [www.DRpower.com](http://www.DRpower.com)

#235451



#227141

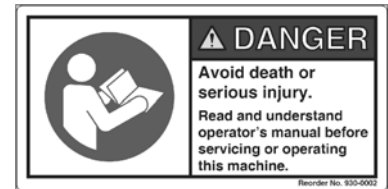

#241801



#241991



#241831

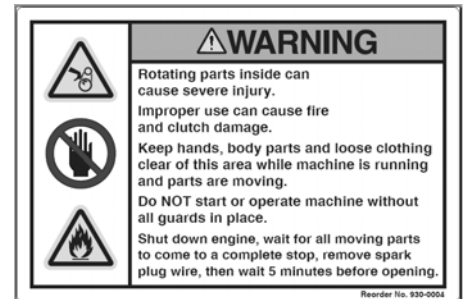

#241821



#241811



#247961

## Protecting Yourself and Those Around You

---

### **WARNING**

This is a high-powered machine, with moving parts operating with high energy. You must operate the machine safely. Unsafe operation can create a number of hazards for you, as well as anyone else in the nearby area. This machine can crush, grind, cut, and sever parts of your body if they enter the inlet or discharge area of your CHIPPER/SHREDDER. Always take the following precautions when using this machine:

- Keep in mind that the operator or user is responsible for accidents or hazards occurring to other people, their property, and themselves.
  - Always wear protective goggles or safety glasses with side shields while using the CHIPPER/SHREDDER to protect your eyes from possible thrown debris.
  - Avoid wearing loose clothing or jewelry, which can catch on moving parts or the material fed into the CHIPPER/SHREDDER.
  - We recommend wearing gloves while using the CHIPPER/SHREDDER. Be sure your gloves fit properly and do not have loose cuffs or drawstrings.
  - Wear shoes with non-slip treads when using your CHIPPER/SHREDDER. If you have safety shoes, we recommend wearing them. Do not use the machine while barefoot or wearing open sandals.
  - Wear long pants while operating the CHIPPER/SHREDDER.
  - Use ear protectors or earplugs rated for at least 20 dba to protect your hearing.
  - Keep bystanders at least 100 feet away from your work area. Stop the engine when another person or pet approaches.
- 

## Safety for Children and Pets

---

### **WARNING**

Tragic accidents can occur if the operator is not alert to the presence of children and pets. Children are often attracted to the machine and the chipping/shredding activity. *Never* assume that children will remain where you last saw them. Always follow these precautions:

- Keep children and pets at least 100 feet from the working area and ensure they are under the watchful care of a responsible adult.
  - Be alert and turn the machine off if children or pets enter the work area.
  - Never allow children to operate the CHIPPER/SHREDDER.
-

## Safety with Gasoline - Powered Machines

---

### **WARNING**

Gasoline is a highly flammable liquid. Gasoline also gives off flammable vapor that can be easily ignited and cause a fire or explosion. Never overlook the hazards of gasoline. Always follow these precautions:

- Never run the Engine in an enclosed area or without proper ventilation as the exhaust from the Engine contains carbon monoxide, which is an odorless, tasteless, and deadly poisonous gas.
  - Store all fuel and oil in containers specifically designed and approved for this purpose and keep away from heat and open flame, and out of the reach of children.
  - Replace rubber Fuel Lines and Grommets when worn or damaged and after 5 years of use.
  - Fill the Gasoline Tank outdoors with the Engine off and allow the Engine to cool completely. Don't handle gasoline if you or anyone nearby is smoking, or if you're near anything that could cause it to ignite or explode. Reinstall the Fuel Tank Cap and Fuel Container Cap securely.
  - If you spill gasoline, do not attempt to start the Engine. Move the machine away from the area of the spill and avoid creating any source of ignition until the gas vapors have dissipated. Wipe up any spilled fuel to prevent a fire hazard and properly dispose of the waste.
  - Allow the Engine to cool completely before storing in any enclosure. Never store a machine that has gas in the tank, or a Fuel Container, near an open flame or spark such as a water heater, space heater, clothes dryer or furnace.
  - Never make adjustments or repairs with the Engine running. Shut down the Engine, disconnect the Spark Plug wire, keeping it away from the Spark Plug to prevent accidental starting, wait 5 minutes before making adjustments or repairs.
  - Never tamper with the Engine's Governor setting. The Governor controls the maximum safe operation speed and protects the Engine. Over-speeding the Engine is dangerous and will cause damage to the Engine and to the other moving parts of the machine. If required, see your authorized dealer for Engine governor adjustments.
  - Keep combustible substances away from the Engine when it is hot.
  - Never cover the machine while the Muffler is still hot.
  - Do not operate the Engine with the Air Cleaner or the Carburetor Air Intake Cover removed. Removal of such parts could create a fire hazard. Do not use flammable solutions to clean the Air Filter.
  - The Muffler and Engine become very hot and can cause a severe burn; do not touch.
- 

## General Safety

---

### **WARNING**

Operating this CHIPPER/SHREDDER safely is necessary to prevent or minimize the risk of death or serious injury. Unsafe operation can create a number of hazards for you. Always take the following precautions when operating this machine:

- Your CHIPPER/SHREDDER is a powerful tool, not a plaything. Exercise extreme caution at all times. The machine is designed to chip wood and shred most organic materials. Do not use it for any other purpose.
  - Thoroughly inspect the area in which you will be working and remove all foreign objects. Look for rope, wire, etc., and remove these objects before chipping/shredding. Inserting these objects into the CHIPPER/SHREDDER Hopper could damage the machine and/or cause injury.
  - Know how to stop the CHIPPER/SHREDDER quickly; see "Stopping the Engine" in Chapter 3.
  - Never operate your unit on a slippery, wet, muddy, or icy surface. Exercise caution to avoid slipping or falling.
  - See manufacturer's instructions for proper operation and installation of accessories. Only use accessories approved by DR Power Equipment.
  - Never use the machine without ensuring that all guards and shields are in place.
  - Never, under any conditions, remove, bend, cut, fit, weld, or otherwise alter standard parts on the CHIPPER/SHREDDER. This includes all shields and guards. Modifications to your machine could cause personal injuries and property damage and will void your warranty.
  - Never use the machine with the Hopper(s) or Discharge Chute removed.
-

## General Safety (continued)

### **WARNING**

- Never place any part of your body in the CHIPPER/SHREDDER Hopper(s), discharge opening, or near any moving part while the machine is running. Keep the area of discharge clear of anything that will obstruct a clear discharge. Wind can also change discharge direction, so be aware. If it becomes necessary to push material into the CHIPPER/SHREDDER Hopper(s), use a small diameter stick, NOT WITH YOUR HANDS.
- Keep your face and body back from the CHIPPER/SHREDDER Hopper(s) to avoid accidental bounce back of any material.
- Do not allow an accumulation of processed material to build up in the discharge area as this will prevent proper discharge and can result in kickback from the CHIPPER/SHREDDER Hopper(s).
- Allow only one person to operate the CHIPPER/SHREDDER at any time.
- Always operate the machine from the Operator Zone (see **Figure 10** on page 13). Never pass or stand on the discharge side of the machine when the Engine is running or the Rotor is turning.
- If the machine should start making an unusual noise or vibration, shut down the Engine, disconnect the Spark Plug Wire, keeping it away from the Spark Plug to prevent accidental starting, wait 5 minutes, then inspect for damage. Vibration is generally a warning of trouble. Check for damaged parts and clean, repair, and/or replace as necessary.
- Never tamper with safety devices. Check their proper operation regularly.
- Never try to pick up, move, or transport the machine while the Engine is running or the Rotor is turning.
- Before performing any maintenance or inspection procedure on the CHIPPER/SHREDDER, shut the Engine OFF, remove the Spark Plug Wire, and keep it away from the Spark Plug.
- Never allow people who do not understand and/or have not read this Safety and Operating Instructions Manual to use the CHIPPER/SHREDDER. Allow only responsible individuals who are familiar with these rules of safe operation to use your machine.
- Never overload or attempt to Chip or Shred material beyond the manufacturer's recommendation. Personal injury or damage to the machine could result.
- While using the CHIPPER/SHREDDER, don't hurry or take things for granted. When in doubt about the equipment or your surroundings, stop the machine and take the time to look things over.
- Never operate the machine when under the influence of alcohol, drugs, or medication.
- Use the machine only in daylight.
- Stay alert for hidden hazards or traffic.
- Keep all nuts and bolts tight and keep the equipment in good operating condition.

### **A Note to All Users**

Under California law, and the laws of some other states, you are not permitted to operate an internal combustion engine using hydrocarbon fuels without an Engine Spark Arrester. This also applies to operation on US Forest Lands. All DR CHIPPER/SHREDDERS shipped to California, New Mexico, and Washington State are provided with Spark Arresters. Failure of the owner or operator to maintain this equipment in compliance with state regulations is a misdemeanor under California law and may be in violation of other state and/or federal regulations. Contact your State Park Association or the appropriate state organization for specific information in your area.

No list of warnings and cautions can be all-inclusive. If situations occur that are not covered by this manual, the operator must apply common sense and operate this DR CHIPPER/SHREDDER in a safe manner. Contact us at [www.DRpower.com](http://www.DRpower.com) or call Toll Free: 1-800-DR-OWNER (376-9637) for assistance.

## Chapter 2: Setting Up The DR CHIPPER/SHREDDER

It may be helpful to familiarize yourself with the controls and features of your DR CHIPPER/SHREDDER as shown in **Figure 1** before beginning these procedures. If you have any questions at all, please feel free to contact us at [www.DRpower.com](http://www.DRpower.com).

### DR CHIPPER/SHREDDER Controls and Features

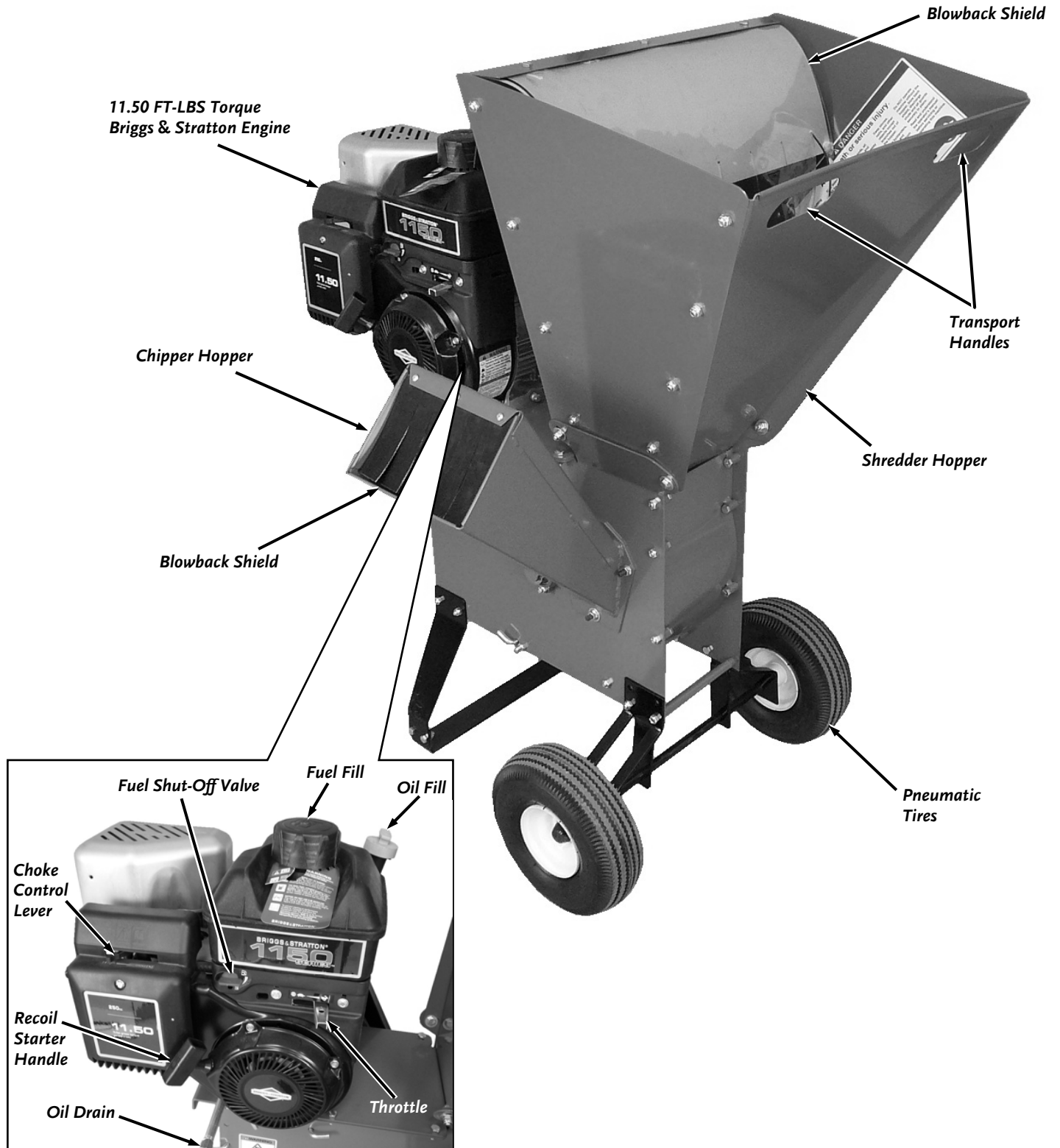

Figure 1

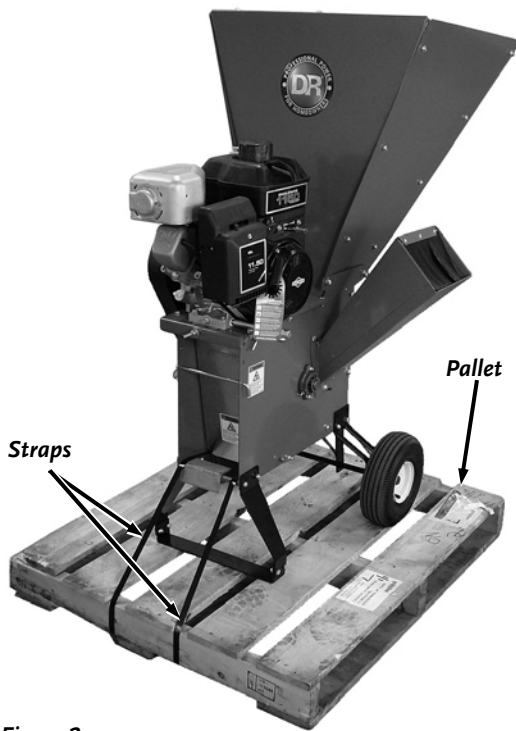

Figure 2

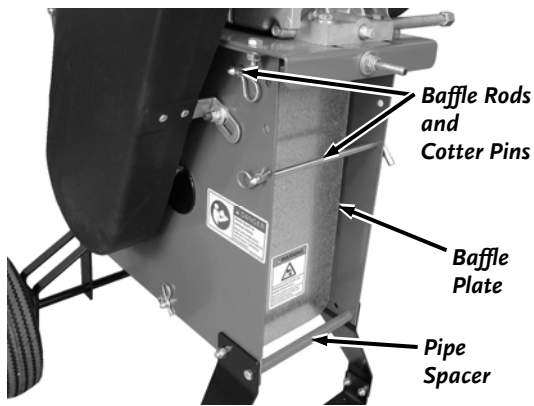

Figure 3

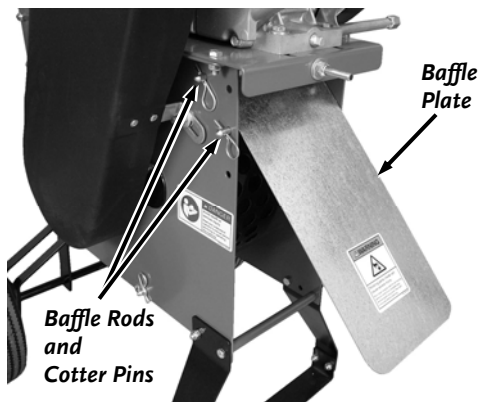

Figure 4

## Specifications

<b>Engine</b>	11.50 FT-LBS Torque Briggs & Stratton
	Please refer to the Engine Owner's Manual for Engine-specifications.
<b>Tire Size</b>	10 inch diameter
<b>Clutch</b>	Centrifugal
<b>Engagement speed</b>	1,000 RPM (the Rotor will turn at idle)
<b>Frame</b>	Welded 12 gauge steel construction
<b>Belt</b>	V-Belt
<b>Size</b>	44 inches
<b>Construction</b>	Wrapped for abrasion resistance
<b>Machine Dimensions</b>	56" L x 41" W x 44" H
<b>Operating Weight</b>	185 pounds
<b>Shipping Weight</b>	215 pounds
<b>Shipping Dimensions</b>	40" L x 34" W x 57" H

## Unpacking the DR CHIPPER/SHREDDER

### Tools and supplies needed:

- Hammer
- Pry Bar
- Wire Cutters or Utility Knife
- Gloves & Safety Glasses

### **CAUTION**

Wear Safety Glasses to protect your eyes from flying debris and Gloves to protect your hands from sharp objects when performing these procedures.

1. Use a Hammer and Pry Bar to separate the bottom Crate Boards from the Pallet and lift the Crate off the Pallet.
2. Cut the Straps that are securing the machine to the Pallet (**Figure 2**).
3. Use the Hand Slots in the Shredder Hopper to tilt and roll the machine from the Pallet.
4. Remove the two Baffle Rods and Cotter Pins that go through the top of the Baffle Plate and the one behind it (**Figure 3**).
5. Move the bottom of the Baffle Plate to the outside of the Pipe Spacer and reinstall the top portion of the Plate using the Baffle Rod and Cotter Pin (**Figure 4**).
6. Reinstall the Baffle Rod and Cotter Pin to hold the Baffle Plate up in the discharge position. Which holes you use depends on the discharge angle desired when chipping/shredding.

If there are any questions contact us at [www.DRpower.com](http://www.DRpower.com) or call 1-800-DR-OWNER (376-9637). Do not discard the shipping materials until you are fully satisfied with your new DR CHIPPER/SHREDDER.



## Adding Oil and Gasoline

### NOTICE

- You **MUST** add oil before starting the Engine. This machine is shipped without oil. Traces of oil may be in the reservoir from factory testing, but you **MUST** add oil before starting the Engine. Fill the reservoir slowly, checking the level frequently to avoid overfilling.
- To get an accurate reading when checking the oil level:
  - The Engine **MUST** be level.
  - Refer to the Engine Manual for detailed information before performing the following procedures.

Engine Oil	SAE 30: above 50 degrees F; 10w-30: 10-90 degrees F; 5w-30: 30 degrees F or below
Fuel	Unleaded gasoline

**NOTE:** Use only the recommended high detergent Engine oil. Other types of oil could cause problems operating your machine. Please refer to your Engine Owner's Manual for more detailed oil information.

- Position the machine so the Engine is level. Remove the Oil Fill/Dipstick (**Figure 5**).
- Initially add 16 oz. of the oil recommended by the Engine Manufacturer. Wait one minute for the oil to settle.
- Check the Oil level on the Dipstick as described in the Engine Manual.
- Continue adding a few ounces of oil at a time, rechecking the level until the oil reaches the full level as indicated in the Engine Manual. Be careful not to overfill.
- Replace the Oil Fill/Dipstick when full.
- Remove the Fuel Fill Cap and fill the Fuel Tank with fresh, unleaded gas (with a minimum of 85 Octane) to approximately 1" to 1-1/2" below the top of the Fill Neck to allow for Fuel expansion (**Figure 8**). Be careful not to overfill and reinstall the Fuel Fill Cap before starting the Engine. See your Engine Owner's Manual for more detailed information.

**NOTE:** To refill the Fuel Tank, turn the Engine OFF, and let the Engine cool at least five minutes before removing the Fuel Fill Cap.

### Check the Tire Pressure

#### Tools Needed:

- Tire Pressure Gauge
  - Air Compressor or Hand Pump
- Remove the Valve Stem Protective Cap (**Figure 6**) and check the Tire pressure with a Tire Pressure Gauge.
  - Check the manufacturers recommended pressure that is stamped on the side of the Tire.

### WARNING

Do not over inflate the Tires. Inflate to the manufacturers recommended pressure.

- If the pressure is too low, add air through the Valve Stem with an Air Compressor or Hand Pump.
- Replace the Valve Stem Protective Cap when finished.



Figure 5



Figure 6

## Chapter 3: Operating The DR CHIPPER/SHREDDER

This chapter covers the procedures for starting and stopping your new DR CHIPPER/SHREDDER and discusses basic operation features. It may be helpful to better familiarize yourself with the features of your CHIPPER/SHREDDER by reviewing **Figure 1** in Chapter 2 before beginning the steps outlined in this chapter.

### **!** WARNING

Read and understand the warnings listed in “Chapter 1 General Safety Rules” before operating this CHIPPER/SHREDDER.

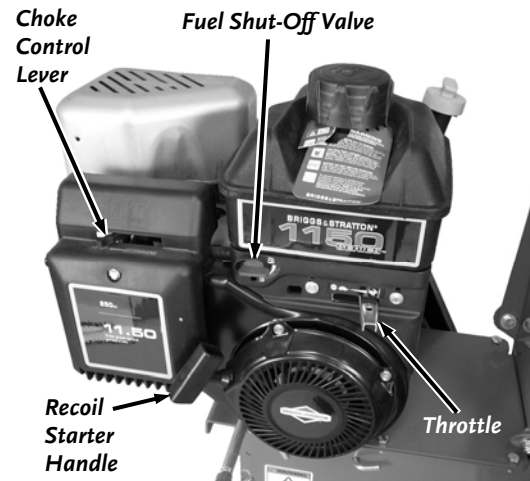

Figure 7

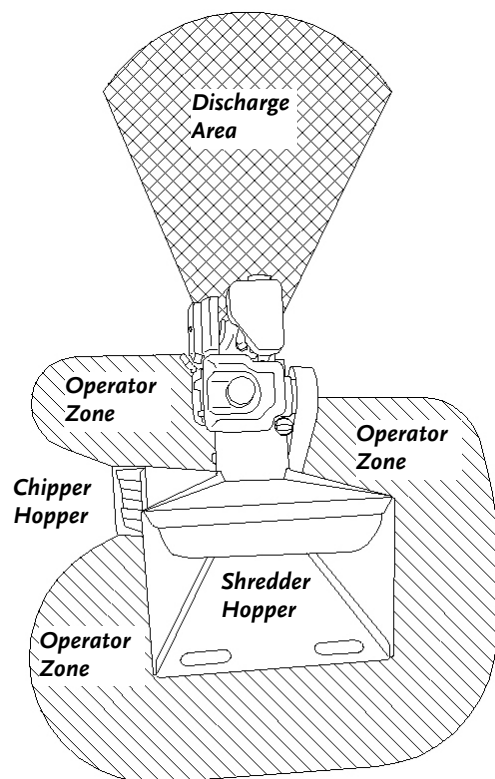

Figure 8

### Starting the Engine

1. Check the Oil and Fuel level every time you use the DR CHIPPER/SHREDDER.
2. Turn the Fuel Shut-Off Valve to the OPEN position (**Figure 7**).
3. Check Inlet Hoppers and Discharge Chute and remove any debris buildup from the machine by first unplugging the Spark Plug Wire and following the instructions on page 16.
4. Move the Choke Control Lever to the right to the Choke position (leave in the Run position to the left if the Engine is already warm).
5. Move the Throttle to the right, FAST (Rabbit) position.
6. Grasp the Recoil Starter Handle and slowly pull until you feel resistance, then pull the cord rapidly to start the Engine. One or two pulls will usually start the DR CHIPPER/SHREDDER.
6. As the Engine warms up, slowly adjust the Choke to the left towards the Run position. Wait until the Engine runs smoothly before each Choke adjustment.
7. When the Engine is warmed up and running smoothly, ensure that the Choke is fully in the Run position to the left.

**NOTE:** The Throttle should always be fully to the right when Chipping/Shredding.

### Stopping the Engine

Move the Throttle Control Lever all the way to the left past the SLOW (Turtle) position to the “STOP” position (**Figure 7**).

**NOTE:** Close the Fuel Shut-Off Valve when transporting or storing the DR CHIPPER/SHREDDER.

### Before You Begin

- Visually check the Chipper Knife for damage each time you use the machine.

**NOTE:** Check for shaft movement while starting the Engine. If the shaft does not turn, STOP the Engine and clean out the Chipper/Shredder Hopper(s) as instructed on page 16.

- ALWAYS operate the DR CHIPPER/SHREDDER from the Operator Zones (**Figure 8**).
- When viewed from the Chipper Hopper side the Rotor turns in a clockwise direction.
- NEVER assume you know where the Chipper Knife is. You do not know where it is.
- ALWAYS stop the Engine when leaving the Operating Zone or when moving

the machine.

## Processing Material

### WARNING

Read and understand the warnings listed in “Chapter 1 General Safety Rules” before operating this CHIPPER/SHREDDER.

- Your DR CHIPPER/SHREDDER can process dry or green material.
- Green material will process quicker and easier than dry material.
- Soft wood processes easier than hard wood.
- Your operator experience will teach you how different materials chip/shred and how fast you can process different materials.
- Most materials process well with the standard screen provided with the DR CHIPPER/SHREDDER.
- It is best to trim off any side twigs from the main branch that you are chipping.
- When chipping branches, sometimes a tail will remain at the end of a branch. To avoid this, rotate the branch while feeding it into the Chipper Hopper. Rotating the branch as you feed it into the machine will improve chipping performance.
- Use caution with small diameter green saplings and branches less than 1" in diameter. Chip these grouped or bundled together to provide support for each other. If the material is 1" or larger, feed only one at a time into the Chipper Hopper.
- Make sure the DR CHIPPER/SHREDDER finishes processing material in the Hopper(s) before shutting the Engine off.

### Using the Chipper Hopper

The Chipper Hopper is mounted on the side of the machine and is designed to chip the larger, heavier materials that the Shredder Hopper isn't designed to handle. The revolving Chipper Knife mounted on a Rotor turns branches fed into the Hopper into “chips”. The Chipper can chip twigs and branches ranging in size from 1" to 2-1/2" in diameter. Cut your materials into manageable lengths of no more than five or six feet long before feeding them into the Chipper Hopper.

### WARNING

The Chipper Hopper must be securely bolted to the side of your DR CHIPPER/SHREDDER before using the machine!

- Feed the branch into Chipper Hopper keeping the branch at the same angle as the Chipper Hopper.
- As the branch becomes short and is at the outside edge of the Chipper Hopper, finish processing it by pushing it in with the next branch.
- Do not force material into the Chipper. If the machine does not chip well, the Chipper Knife may need sharpening or to be replaced.
- Extremely hard knots will not process very well. Push any short stubs that have not self-fed through the Chipper, with the next branch to be chipped.

### NOTICE

Never throw remaining stubs or knots into the Shredder Hopper; damage will result.

- Overloading the Chipper Hopper will cause the rotor speed to decrease. If you hear the Engine RPM decreasing, stop feeding material into the Chipper Hopper until the Engine has returned to full speed.
- NEVER allow processed material to build up within 3" of the Discharge opening. Move the DR CHIPPER/SHREDDER or the pile as needed. Failure to do so could result in unnecessary jamming of the machine.
- To move a pile of processed material, first shut off the Engine, and use a spade, rake, or long handle tool; NEVER use your hands or feet!

### NOTICE

If you jam the machine and do not stop the Engine, it can damage the machine. This damage can be costly and not covered under warranty. See “To Free a Jammed Flywheel” on page 16.

## Using the Shredder Hopper

The Shredder Hopper is located on the top of the DR CHIPPER/SHREDDER and is the opening into which all materials to be shredded should be fed. You can shred most organic materials. A flex guard, or blowback shield is attached to the Hopper. You must push material past this flap using a wooden stick in order to enter the main Shredding Chamber where revolving steel Hammers do the shredding.

### CAUTION

The Blowback Shield is an important feature; it prevents kickback of materials! Do not use your machine unless the Blowback Shield is securely fastened in place.

- Due to the wide variety of materials that you can shred, and their very different physical characteristics, only feed limited quantities of any material into the Shredder Hopper at first. Increase the amount and length of material if you find that the material is processing without any difficulty. Your judgment and operator experience is very important. Be sure not to overload the machine by feeding too much material into the Hopper at one time. If you hear the speed of the Engine decreasing, stop feeding material into the machine at once. Do not resume feeding the machine until the Engine has returned to full speed.
- The maximum diameter of material that you can shred is 3/8". Feed any larger material through the Chipper Hopper. Material larger than 3/8" can cause serious damage to any of the internal parts of the Shredding Chamber. Inspect the DR CHIPPER/SHREDDER after every use for bent Hammers, missing Spacers, clogging, or damage to the Screen or any other obvious problems. If damage occurs, the Rotor Assembly can become unbalanced causing excessive vibration. If used in this condition, damage can occur. Do not use the machine if vibration is present. Vibration is generally a warning sign of trouble.
- You can feed several small branches into the Shredder Hopper at once providing their combined diameter is less than 3/8". Cut branches longer than three (3) feet to make them more manageable. Allow green materials to dry, or process in small batches with dry materials to avoid winding around the Rotor Assembly.
- Wet materials will clog the machine easily. If clogging occurs, stop the Engine; remove the screen and process material without it. Processing in this way will reduce the amount of reduction, but will reduce clogging.

MATERIALS BEST SUITED FOR SHREDDING			
Leaves	Flowers	Corn Stalks	Roots
Soil	Palm frond tops	Grass clippings	Garden debris
Potato vines	Straw and Hay	Hedge clippings	Tomato vines
Manure	Kitchen Waste	Small branches	

### WARNING

The Hammers within the Shredding Chamber can tug suddenly at material fed into the Shredder Hopper. Do not hold on tightly to branches and vines, and do not feed material straight down into the Hopper with your arm pointing downward toward the opening. Instead, keep your arms parallel to the ground and several inches above the top edge of the Hopper.

## To Free a Jammed Rotor

### **! WARNING**

Before performing any maintenance procedure or inspection, stop the Engine, wait five (5) minutes to allow all moving parts to come to a complete stop and cool. Disconnect the Spark Plug Wire, keeping it away from the Spark Plug.

1. Remove any material left in the Chipper and Shredder Hoppers with a wooden stick.
2. Check the Discharge Opening for clogs. If it is clogged, clear it with a stick.
3. Also, with a stick, loosen and remove any material left in the Chipping/Shredding Chamber.
4. Start the machine and allow any remaining material in the Chipping/Shredding Chamber to discharge.
5. If the Chipping/Shredding Chamber does not clear and the Rotor is still jammed, repeat the above process.
6. Be certain the Chipping/Shredding Chamber is clear before trying to process more material into the Hopper, clogging could result in Belt or Clutch failure.

## To Clean Out a Clogged Shredder

1. Remove the Baffle Plate by removing the Cotter Pin on the Baffle Rod and then removing the Baffle Plate (**Figure 9**).
2. Remove the Screen by removing the Cotter Pin on the Screen Rods and then removing the Screen (**Figure 10**). Remove any debris from the Screen.
3. Remove any debris wrapped around the Hammers, Shaft or any other portion of the Rotor Assembly (**Figure 11**).
4. Reposition the Screen and reinstall the Top and Lower Screen Rods. Secure the Rods with the Cotter Pins.
5. Reposition the Baffle Plate and reinsert the Baffle Rod. Secure the Rod with the Cotter Pin.
6. Reconnect the Spark Plug wire, start the machine, and allow any remaining material in the Shredding Chamber to discharge.
7. If the Shredding Chamber does not clear, repeat the above process.

### **NOTICE**

Be certain the Shredding Chamber is clear before trying to process more material into the Hopper, clogging could result in Belt or Clutch failure.

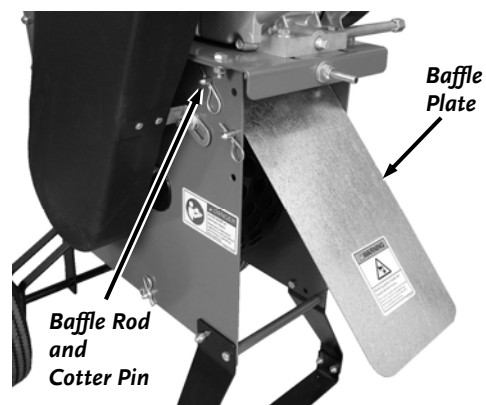

Figure 9

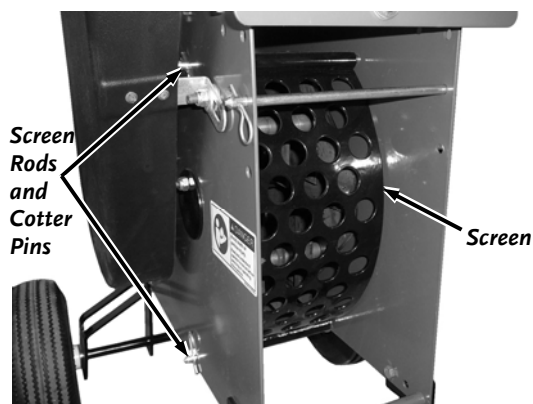

Figure 10

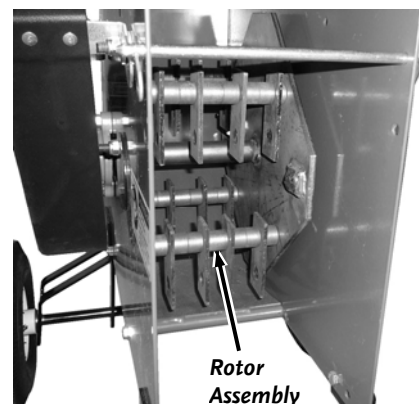

Figure 11

## Chapter 4: Maintaining The DR CHIPPER/SHREDDER

Regular maintenance is the way to ensure the best performance and long life of your machine. Please refer to this manual and the Engine Manufacturer's Owner's Manual for maintenance procedures. Service intervals listed in the checklist below supersede those listed in the Engine Manufacturer's Owner's Manual.

### **⚠ WARNING**

Before performing any maintenance procedure or inspection, stop the Engine, wait five (5) minutes to allow all parts to cool. Disconnect the Spark Plug Wire, keeping it away from the Spark Plug.

### Regular Maintenance Checklist

PROCEDURE	BEFORE EACH USE	EVERY 8-10 HOURS	EVERY 40 HOURS	EVERY 100 HOURS
Check Engine Oil Level	▲			
Check General Equipment Condition	▲			
Check that the Shaft turns freely	▲			
Clean Engine Exterior & Cooling Fins	▲			
Inspect Knife for damage	▲			
Check Knife for Sharpness		▲		
Check Knife Attachment Screws		▲		
Check Rotor Hammers/Spacers for Wear		▲		
Check Side Bearing Collar Set Screws		▲		
Lubricate Side Bearings		▲		
Check Belt Tension and Condition	Break in period - once every hour for first 5hrs	▲		
Clean Air Filter		▲		
Replace Air Filter			▲	
Check Tire Pressure			▲	
Change Engine Oil	1 <sup>st</sup> time 5 hrs		▲	
Replace Drive Belt and Spark Plug				▲
Reverse Rotor Hammers				▲

### Removing and Replacing the Engine Oil

#### Tools and Supplies Needed:

- 5/8" Wrench
- Rags and approved Container (for waste oil)
- Small funnel
- Engine Oil (see your Engine Manual for Oil specifications)

**NOTE:** Drain the oil when the Engine is warm; warm oil drains quickly and completely.

1. Level the machine, remove the Oil Fill/Dipstick, and use a 5/8" Wrench to remove the Oil Drain Cap allowing the used oil to drain completely into a Waste Oil Container (**Figure 12**).
2. Replace the Oil Drain Plug, and refill with new oil (see "**Adding Oil and Gasoline**" on page 10).

**NOTE:** Be sure to use environmentally safe disposal procedures in the disposing of the used oil.



Figure 12

## Grease Fittings

Your DR CHIPPER/SHREDDER was greased at the Factory. The operator needs to lubricate the Chipper Side and Drive Side Bearings periodically.

### Tools and Supplies Needed:

- Flexible hose grease gun
- Lithium grease
- Clean cloth
- 5/32" Allen Wrench
- Loctite® 243 (if set screws are loose)

1. Wipe all dirt, etc., from the Grease Fittings on both Bearings with a clean cloth (**Figure 13**).
2. Apply no more than three pumps of quality general-purpose lithium grease with a hand-pumped grease gun to each Grease Fitting, one on the Chipper Side Bearing, and one on the Drive Side Bearing (not shown). To access the Drive Side Bearing, you will have to remove the Belt Guard (see below).

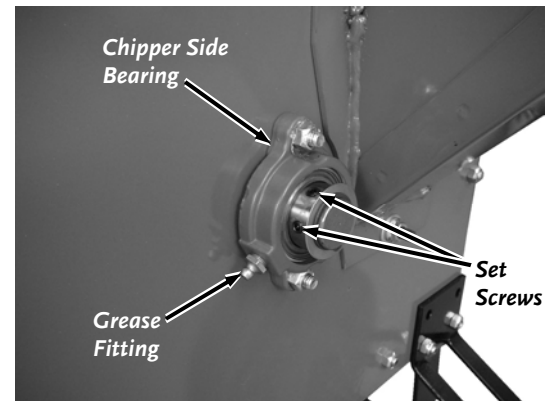

Figure 13

### NOTICE

Over lubrication can damage Bearings.

3. After greasing, check the Side Bearing Collar Set Screws (**Figure 15**) for tightness with a 5/32" Allen Wrench. There are two Set Screws per Bearing. If they are loose, reset them with Loctite® 243, obtainable at most hardware stores.

## Tensioning, Replacing, and Aligning the Drive Belt

### NOTICE

Use only a DR Belt on your machine. The Belt has been thoroughly tested and proven for many hours of use.

### CHECKING AND SETTING BELT TENSION

#### Tools and Supplies Needed:

- Two 1/2" Wrenches
- Straight Edge

1. Remove the Belt Guard by removing the two Locknuts and four Washers with a 1/2" Wrench (**Figure 14**).

**NOTE:** One Washer is located under the Belt Guard Bracket and one on top of the Bracket. Make sure you install the Washers in these same positions.

2. Place a straight edge onto the full length of the Belt (**Figure 15**).
3. Push on the Belt with about three pounds of pressure. The Belt should move approximately 3/8". If the distance is close to 3/8" no tension adjustment is needed. If it is not close to 3/8" adjust per the following directions.
4. Remove the Cotter Pin and Baffle Rod and set the Baffle Plate aside for better access under the Engine (**Figure 14**).

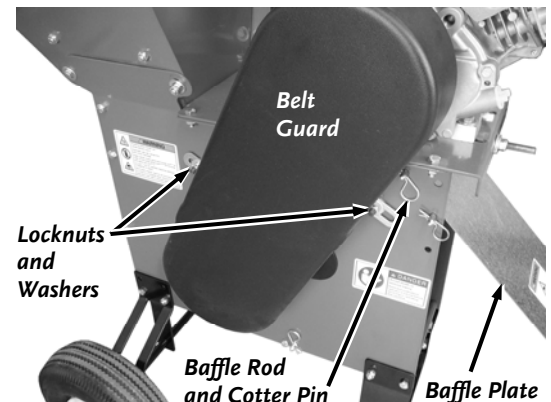

Figure 14

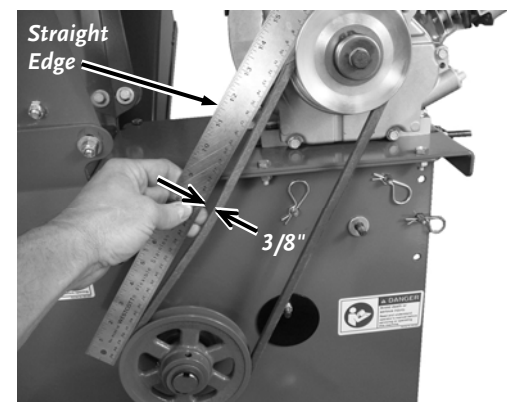

Figure 15

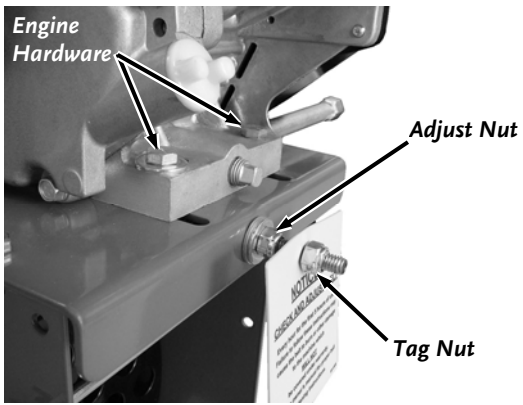

Figure 16

5. Loosen the four Engine Bolts using two 1/2" Wrenches (**Figure 16**).
6. Using a 1/2" Wrench, turn the Tag Nut away from the Adjust Nut.
7. Turn the Adjust Nut in against the Frame to tighten (if Belt is too loose) or out to loosen (if Belt is too tight) for the correct Belt tension.
8. When the Belt is at the proper tension tighten the Engine Hardware.
9. Screw the Tag Nut up to the Adjust Nut.
10. Replace the Baffle Plate and Belt Guard.

### REPLACING THE BELT

#### Tools and Supplies Needed:

- Two 1/2" Wrenches

1. Follow the disassembly steps in the previous "Checking and Setting Belt Tension" section (steps 1 and 4 through 6).
2. Loosen the Adjust Nut to move the Engine forward until the Belt can be removed.
3. Install the new Belt onto the Clutch and Rotor Pulley. Turn the Adjust nut against the Frame to tighten the Belt and follow the steps that apply in the "Checking and Setting Belt Tension" section to set Belt tension (steps 2, 3 and 7).
4. When the Belt is at the proper tension tighten the Engine Hardware.
5. Screw the Tag Nut up to the Adjust Nut.
6. Replace the Baffle Plate and Belt Guard.

### CHECKING AND SETTING BELT ALIGNMENT

#### Tools and Supplies Needed:

- 1/2" Wrench
- Straight Edge
- 5/32" Allen Wrench, Snap Ring Pliers and Loctite® 243\*

\*(if alignment is needed)

1. Remove the Belt Guard by following step 1 of the "Checking and Setting Belt Tension" section.
  2. Place one end of a Straight Edge across the face of the Rotor Pulley and the other end near (but not touching) the Clutch (**Figure 17**).
  3. The Straight Edge should be parallel with the Belt. If the gap between the top portion of the Straight Edge to the Belt is equal to the gap between the bottom portion of the Straight Edge to the Belt, no adjustment is needed (continue at step 4). If the gaps are not equal, adjustment is needed (continue to the following step "a"):
- a) Write down the difference in the gaps to use for adjustment.
  - b) Remove the Belt from the Rotor Pulley by following the steps as described in the previous "Checking and Setting Belt Tension" section (steps 4 through 7).
  - c) Remove the two Set Screws with a 5/32" Allen Wrench (**Figure 18**).
  - d) Remove the Retaining Ring with the Retaining Ring Pliers
  - e) Remove the Shims and Rotor Pulley from the shaft.

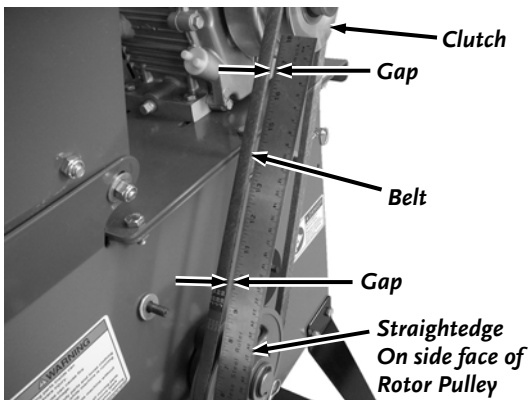

Figure 17

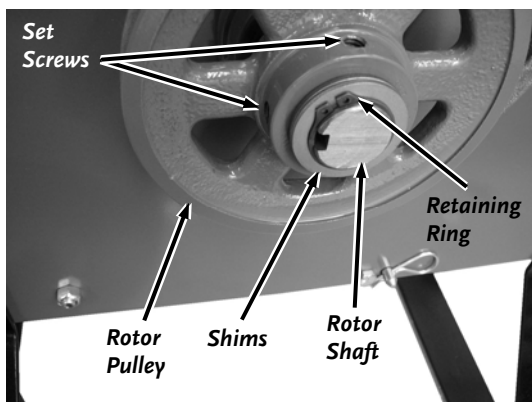

Figure 18



**Note:** Make sure the Shaft Key stays in the slot of the Shaft when the Pulley is removed. If it does come out of the slot, slide it back in for assembly.

- f) Place enough Shims on the Shaft to equal the measurement you wrote down.
  - g) Reinstall the Pulley (line up with the key on the shaft) and any remaining Shims on the outside of the Pulley. Secure with the Retaining Ring (ensure it is locked into the groove).
  - h) Apply Loctite® 243 to the threads of the Set Screws and reinstall them into the Pulley Hub tightly against the Shaft.
  - i) Install the Belt and recheck the alignment.
  - j) Set Belt tension as described in the “Checking and Setting Belt Tension” section.
4. Reinstall the Belt Guard.

**NOTE:** Check and re-tighten (if necessary) the Drive Belt after an initial break-in period of one hour.

### Knife Sharpening

- You should never attempt to sharpen the Chipper Knife freehand; take the Knife to a machine shop for proper sharpening.
- It is extremely important to consistently maintain the 45-degree angle for proper performance.
- Excessive heat generated during the sharpening process will damage Knives and weaken the metal.
- How many times a Knife can be sharpened is determined by how much material needs to be taken off to sharpen or to compensate for dents or gouges.
- A new Chipper Knife has a 5/16" measurement between the short side bevel edge and the Knife mounting holes (**Figure 19**).

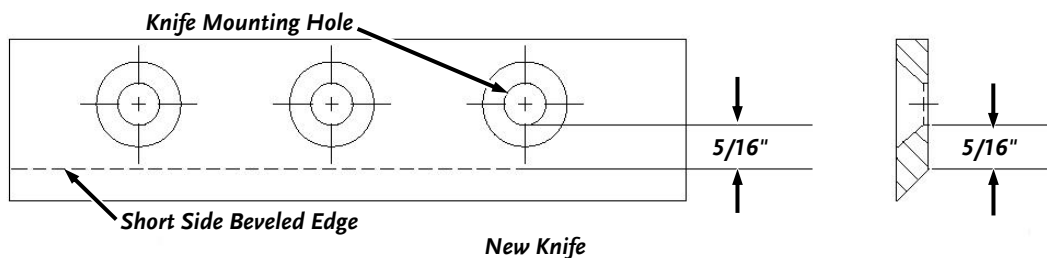

**New Knife**

**Figure 19**

- The knife should never be sharpened to the extent that more than 3/32" is taken off this measurement.
- Once this measurement is below 7/32" (**Figure 20**), or if you are unable to remove dents or gouges with these guidelines, replace the Knife.

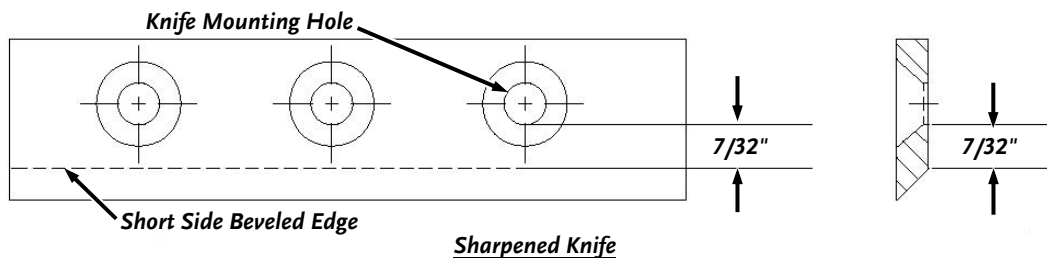

**Sharpened Knife**

**Figure 20**

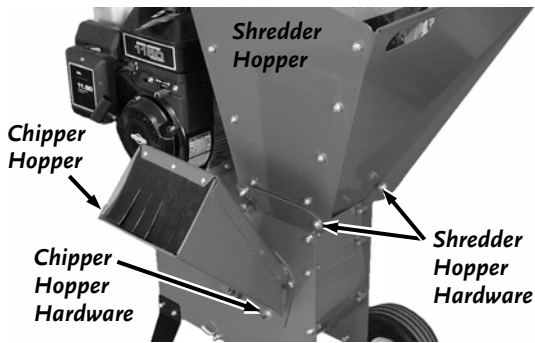

Figure 21

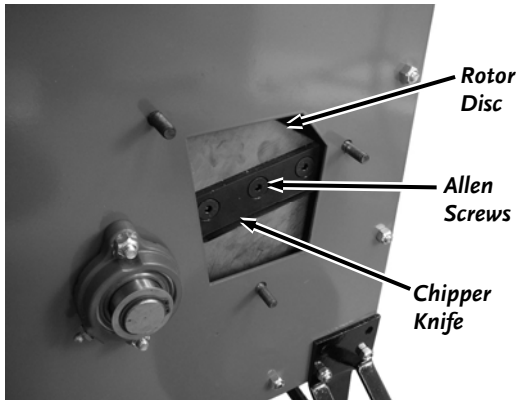

Figure 22

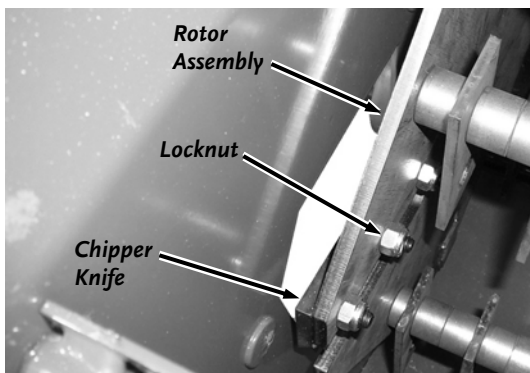

Figure 23

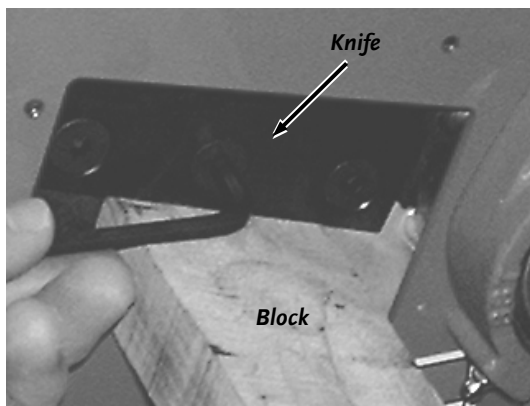

Figure 24

## Replacing the Chipper Knife

### Tools and Supplies needed:

- Two 1/2" Wrenches
- 3/16" Allen Wrench
- Awl
- Gloves

1. Use two 1/2" Wrenches to remove the Shredder Hopper (**Figure 21**).
  2. Use a 1/2" Wrench to remove the Chipper Hopper.
  3. Rotate the Rotor Assembly using a stick until the three countersunk Allen Screws attaching the Knife to the Rotor are visible through the Chipper Hopper Opening (**Figure 22**).
  4. Clean out the heads of the Allen Screws with an awl or sharp tool.
  5. Insert a 3/16" Allen wrench into the head of a screw and a 1/2" Wrench on the Locknut on the inside (**Figure 23**) and remove the Locknut and Screw.
- Tip:** You may want to support the Rotor by inserting a block of wood under the knife while loosening the Locknuts and Screws (**Figure 24**).
6. Repeat Step 5 for the remaining two Allen Screws.
  7. Remove the dull or damaged Knife and visually inspect the Chipper Rotor Slot and Knife mounting area and be sure they are clean. Metal burrs may need filing so that the replacement Knife will be able to mount flush against the Chipper Rotor.
  8. Install a new or sharpened Knife and finger tighten the Allen Screws and Locknuts to hold the Knife to the Rotor.
  9. Using a 3/16" Allen Wrench on the Screw and a 1/2" Wrench on the Locknut, tighten the center Screw, then tighten the outer Screw, and finally tighten the inner Screw.
  10. Double-check all three Screws for tightness one more time.
  11. Reinstall the Shredder and Chipper Hoppers.

## Maintaining the Shredder Hammers

When the hard steel Hammers of the Rotor Assembly become dull or round on the cutting edge, they may be rotated or reversed.

**NOTE:** The Hammers have four cutting edges that may be used before replacement is necessary. To reverse the Hammers, proceed as follows:

### Tools and Part Required

- Two 1/2" Wrenches
- Hammer and Punch

1. Remove the Baffle Rod and Cotter Pin to remove the Baffle Plate (**Figure 25**).
2. Remove the Screen Rods and Cotter Pins to remove the Screen (**Figure 26**).
3. Remove the Belt Guard with a 1/2" Wrench.
4. Loosen the Access Cover Locknut with a 1/2" Wrench and rotate the round Access Cover Plate to expose the Access Hole.
5. Rotate the Rotor Assembly to gain access to the Roll Pin at the end of the Rod (**Figure 27**).
6. Drive out the Roll Pin with a punch and Hammer.
7. Align the Rod with the Access Hole.
8. Carefully remove the Rod through the Access Hole and at the same time remove the Hammers and spacers from the Rod leaving them in the same order as you removed them.
9. Now reverse each Hammer (end to end) by using the lower hole in the Hammer.
10. Slide the Rod back through the Access Hole as you reinstall the Hammers and Spacers in the same order as removed.

**NOTE:** Be sure you reinstall the Hammers and Spacers in exactly the same order that they were removed. Refer to the Rotor Assembly Schematic in Chapter 6 for the correct order.

11. Replace the old Roll Pin with a new one.
  12. Repeat steps 5 through 11 for the remaining three Hammer Rods.
- Tip:** To remember which Hammer Rod you have reworked, it may be helpful to mark the end of the Rods with a marker or tape.
13. Reinstall the Access Cover Plate, Belt Guard, Screen, and the Baffle Plate.

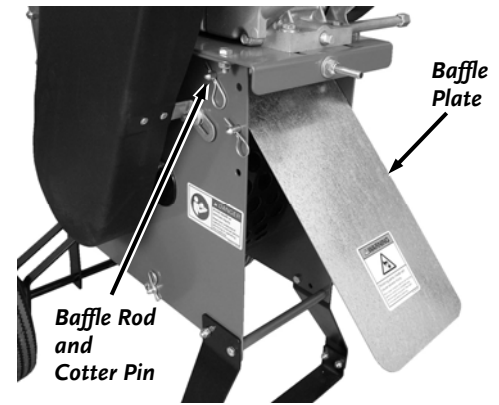

Figure 25

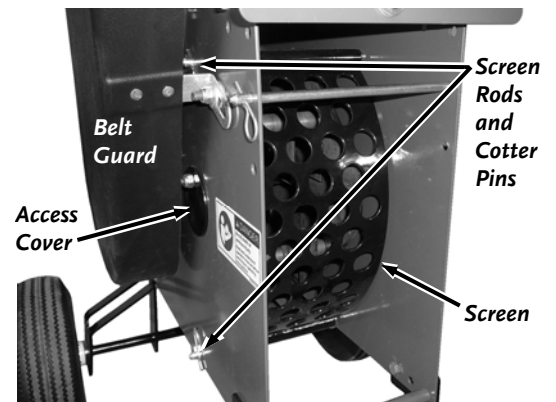

Figure 26

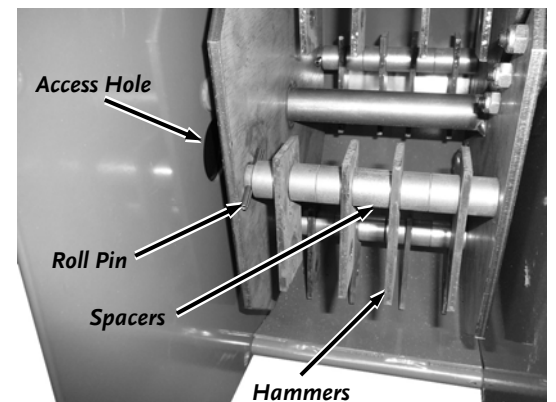

Figure 27

## Removing and Replacing the Clutch

The design of the Clutch on your machine is for rugged, dependable service, however, it is important to understand the limitations of a Clutch. The Clutch design is to provide load free starting of the Engine, and slippage under excessive overloading of the driven application. These features help protect the Engine from damages such as broken crankshafts and starters. The Clutch on this machine is permanently lubricated and does not require oil or grease. The Drum, Shoes, and Springs in the Clutch are normal wear items. If, after long periods of use, the Drum wobbles excessively, or if you notice decreased performance of the Clutch, replace the Clutch.

The Clutch obtains its power from the Engine RPM. The lower the engagement speed, and the higher the maintained Engine speed, the more torque the Clutch can transfer to the driven unit. **NEVER operate the DR CHIPPER/SHREDDER Engine at less than full RPM.**



Figure 28

### Tools and Supplies Needed:

- Two 1/2" Wrenches
- 9/16" Wrench
- Anti-seize compound

1. Remove the Belt as described in the "Replacing The Belt" section.
2. Remove the Clutch from the Engine Crankshaft by removing the Clutch Bolt and Washer and then slide the Clutch Assembly from the Crankshaft (**Figure 28**) (any Spacers remain on the Crankshaft).

**Tip:** Hold the Hub with Vise Grips while loosening the Clutch Bolt.

3. Remove the Key from the Keyway in the Engine Crankshaft and set it aside.
4. Clean the Engine Crankshaft and remove any burrs, then apply anti-seize compound to the Crankshaft.
5. Install the Key in the Keyway of the Engine Crankshaft, align the Key with the slot in the new Clutch Hub, and then slide the new Clutch Assembly onto the Crankshaft followed by the Washer and Clutch Bolt. Tighten the Bolt securely.
6. Reinstall the Drive Belt and set the Belt tension as described in the "Checking and Setting Belt Tension" section.
7. Reinstall the Belt Guard and Baffle Plate.

## Chapter 5: Troubleshooting

Most problems are easy to fix. Consult the Troubleshooting Table below for common problems and their solutions. If you continue to experience problems, contact us at [www.DRpower.com](http://www.DRpower.com) or call toll-free 1-800-DR-OWNER (376-9637) for support.

### WARNING

Shut down the Engine, remove the Spark Plug Wire, and wait 5 minutes before performing any maintenance procedure or inspection on the Chipper/Shredder.

### Troubleshooting Table

SYMPTOM	POSSIBLE CAUSE
<i>Recoil will not pull out or is difficult to pull.</i>	<ul style="list-style-type: none"> <li>⇒ Remove any built-up debris from the Chipper/Shredder Hopper Inlet(s) and Discharge Chute.</li> <li>⇒ There may be an oil compression lock in the cylinder. Take out the Spark Plug; hold a rag over the Spark Plug hole and pull the Recoil Cord several times to blow out any oil in the Cylinder. Wipe off the Spark Plug and reinstall it.</li> <li>⇒ Check the Engine oil level; the Engine may be seized.</li> <li>⇒ The Recoil may be broken or jammed. Visit our website at <a href="http://www.DRpower.com">www.DRpower.com</a>.</li> </ul>
<i>The Engine will not start.</i>  <i>(Please refer to the Engine Owner's Manual for Engine-specific procedures.)</i>	<ul style="list-style-type: none"> <li>⇒ Check the oil and gas level.</li> <li>⇒ Make sure that the Fuel Shut-Off is in the ON position.</li> <li>⇒ Check that the Spark Plug Wire is attached.</li> <li>⇒ The Air Filter may be dirty; change it following the procedure in the Engine Owner's Manual.</li> <li>⇒ The gas may be old; change it if necessary. Use a fuel stabilizer if you keep gas longer than one month.</li> <li>⇒ Check the Throttle and Choke settings, adjustment and travel.</li> <li>⇒ The Spark Plug may be dirty or cracked; change it if necessary. If it's oily, leave it out, hold a rag over the Plug Hole and pull the Recoil Cord several times to blow out any oil in the Cylinder, then wipe off the Plug and reinsert it.</li> <li>⇒ If your Engine still won't start, visit our website at <a href="http://www.DRpower.com">www.DRpower.com</a>.</li> </ul>
<i>The Engine lacks power or is not running smoothly.</i>  <i>(Please refer to the Engine Owner's Manual for engine-specific procedures.)</i>	<ul style="list-style-type: none"> <li>⇒ Make sure the Choke Lever is all the way to the RUN position (left).</li> <li>⇒ Make sure that the Throttle Lever is all the way to the right (FAST- Rabbit).</li> <li>⇒ The Air Filter may be dirty; change it following the procedure in the Engine Owner's Manual.</li> <li>⇒ The Spark Plug may be dirty or cracked; change it if necessary. If it's oily, leave it out, hold a rag over the Plug Hole and pull the Recoil Cord several times to blow out any oil in the Cylinder, then wipe off the Plug and reinsert it.</li> <li>⇒ The gas may be old; change it if necessary. Use a fuel stabilizer if you keep gas longer than one month.</li> <li>⇒ The Engine oil may be dirty. Change it if necessary.</li> <li>⇒ Check that the Cooling Fins are clean and free of debris. Clean as needed.</li> <li>⇒ If your Engine still lacks power, visit our website at <a href="http://www.DRpower.com">www.DRpower.com</a>.</li> </ul>
<i>Engine smokes.</i>  <i>(Please refer to the Engine Owner's Manual for engine-specific procedures.)</i>	<ul style="list-style-type: none"> <li>⇒ Check the oil level and adjust as needed.</li> <li>⇒ You may be operating the machine on too great an incline. The machine should be level.</li> <li>⇒ The Air Filter may be dirty; change it following the procedure in the Engine Owner's Manual.</li> <li>⇒ You may be using the wrong oil - too light for the temperature. Refer to your Engine Owner's Manual for detailed information.</li> <li>⇒ Check that the Cooling Fins are clean and free of debris. Clean as needed.</li> <li>⇒ If your Engine still smokes, visit our website at <a href="http://www.DRpower.com">www.DRpower.com</a>.</li> </ul>

## Troubleshooting Table (Continued)

### WARNING

Shut down the Engine, remove the Spark Plug Wire, and wait 5 minutes before performing any maintenance procedure or inspection on the Chipper/Shredder.

SYMPTOM	POSSIBLE CAUSE
<i>The Engine runs but the Rotor doesn't rotate.</i>	<ul style="list-style-type: none"> <li>⇒ The Throttle Lever should be in the FAST (Rabbit) position to engage the Clutch.</li> <li>⇒ The Drive Belt is loose, off or broken. Reinstall, re-tension, or change Belt (refer to "Chapter 4: Maintaining the DR Chipper/Shredder").</li> <li>⇒ Remove any built-up debris from the Chipper/Shredder Hopper Inlet(s) and Discharge Chute.</li> <li>⇒ The inner Shoes of the Clutch are worn and/or the Clutch Shoe Retaining Springs are weak or broken. Change the Clutch (refer to "Chapter 4: Maintaining the DR Chipper/Shredder").</li> </ul>
<i>Shredding and chipping action seems too slow or Rotor stalling.</i>	<ul style="list-style-type: none"> <li>⇒ The Engine speed is too slow causing the Belt to slip. Run the Engine at full throttle (Rabbit).</li> <li>⇒ Check for loose or damaged Drive Belt; tighten or replace.</li> <li>⇒ Check for a dull or damaged Knife; sharpen or replace the Knife. Check for a clogged Shredder Screen, clean if necessary.</li> </ul>
<i>Belt frays or falls off frequently.</i>	<ul style="list-style-type: none"> <li>⇒ The Drive Pulley or Clutch groove may be nicked. Check the Drive Belt for wear and hard spots. File off any nicks on the Drive Pulley or Clutch.</li> <li>⇒ The Drive Belt may be stretched; readjust or replace it.</li> </ul>
<ul style="list-style-type: none"> <li>- Clutch overheats.</li> <li>- Belt burns.</li> <li>- Rotor won't turn.</li> </ul>	<ul style="list-style-type: none"> <li>⇒ Immediately stop the Engine and remove the Spark Plug Wire.</li> <li>⇒ Turn the Rotor with a wooden stick to be sure it turns freely.</li> <li>⇒ Check the Drive Belt tension.</li> <li>⇒ Remove any built-up debris from the Chipper/Shredder Hopper Inlet(s) and Discharge Chute.</li> </ul>
<i>The machine has excessive vibration.</i>	<ul style="list-style-type: none"> <li>⇒ Check for a dull or damaged Knife; sharpen or replace the Knife.</li> <li>⇒ The Rotor is out of balance. Check the Rotor Assembly for any missing or broken Hammers or Spacers; replace if necessary.</li> <li>⇒ The Knife may not be seated properly on the Rotor. Loosen the Knife mounting screws, reset the Knife, and tighten the screws.</li> <li>⇒ If your machine still exhibits excessive vibration, visit our website at <a href="http://www.DRpower.com">www.DRpower.com</a>.</li> </ul>
<i>When chipping, the log seems to vibrate excessively and "hammers" my hands.</i>	<ul style="list-style-type: none"> <li>⇒ The Knife is dull; sharpen or replace it.</li> </ul>



## Chapter 6: Parts Lists and Schematic Diagrams

---

### **Parts List – DR BASIC MACHINE ASSEMBLY**

**NOTE:** Part numbers listed are available through DR Power Equipment.

<u>Ref#</u>	<u>Part#</u>	<u>Description</u>	<u>Ref#</u>	<u>Part#</u>	<u>Description</u>
01	167791	Bolt, HHCS, 5/16-18 x 3/4"	08	305141	Bolt, HHCS, 5/16-18 x 8", Black
02	310311	Plate, Top	09	305081	Ring, Retaining
03	186131	Locknut, 5/16-18	10	305111	Shim
04	184441	Bearing	11	310291	Chipper Side Weldment
05	310301	Drive Side Weldment	12	305161	Scroll Weldment
06	146051	Bolt, HHCS, 5/16-18 x 1"	13	143121	Bolt, HHCS, 5/16-18 x 1-1/4"
07	310391	Rotor Assembly	14	185941	Cover, Access



**Schematic – DR BASIC MACHINE ASSEMBLY**

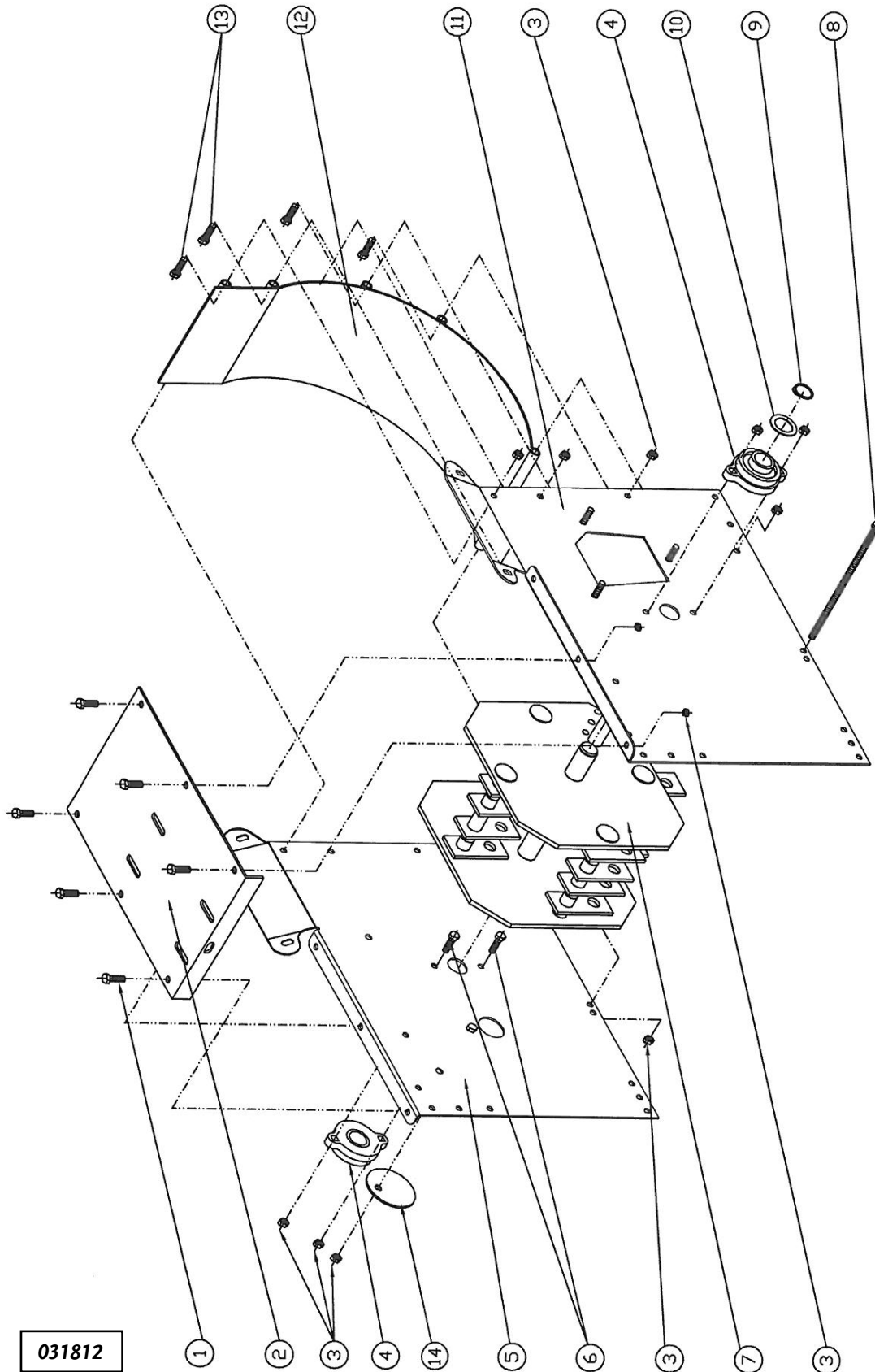

## Parts List and Schematic– DR FRONT FOOT, AXLE AND TIRES

**NOTE:** Part numbers listed are available through DR Power Equipment.

Ref#	Part#	Description	Ref#	Part#	Description
01	310401	Basic Machine	07	305131	Bolt, HHCS, 5/16-18 x 8"
02	167791	Bolt, HHCS, 5/16-18 x 3/4"	08	154651	Wheel, 4.10/3.50 x 4"
03	285901	Nut, Nylon Lock, 5/16-18	09	154881	Cap, Push Nut
04	310371	Leg	10	310411	Axle
05	305171	Spacer, Pipe	11	185861	Bracket, Axle
06	310381	Stand			

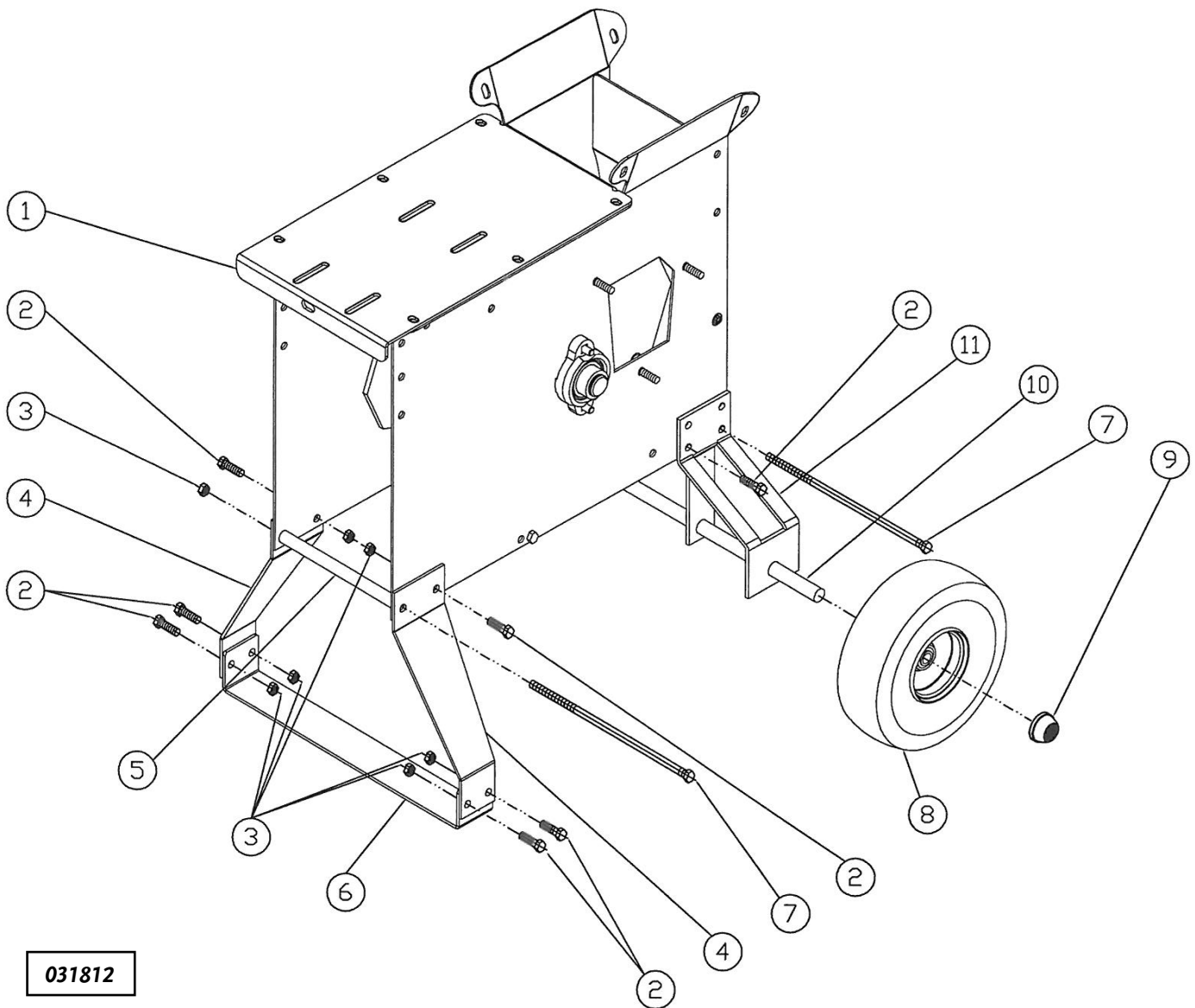

## Parts List and Schematic – DR BELT GUARD AND ENGINE

**NOTE:** Part numbers listed are available through DR Power Equipment.

<u>Ref#</u>	<u>Part#</u>	<u>Description</u>	<u>Ref#</u>	<u>Part#</u>	<u>Description</u>
01	285901	Nut, Nylon Lock, 5/16-18	10	134431	Bolt, HHCS, 5/16-18 x 1-1/2"
02	145151	Washer, Flat, 5/16", USS	11	310431	Tensioner, Belt
03	292651	Guard Assembly, Belt	12	241671	Engine
04	144451	Bolt, HHCS, 3/8-24 x 1-1/4"	13	146061	Screw, Set, 5/16"-18 x 5/16"
05	216511	Washer, Lock, 3/8"	14	305111	Shim
06	162081	Washer	15	305081	Ring, Retaining
07	194931	Belt	16	305211	Clutch
08	203571	Pulley	17	148551	Key, 1/4" x 1/4" x 1-1/2"
09	142321	Key, 1/4" x 1/4" x 1"	<b>Not Illustrated</b>		
				294061	Pipe, Oil Drain, 1/4" NPT x 6" Galv.
				294071	Cap, Pipe, Oil Drain, 1/4" NPT, ZP

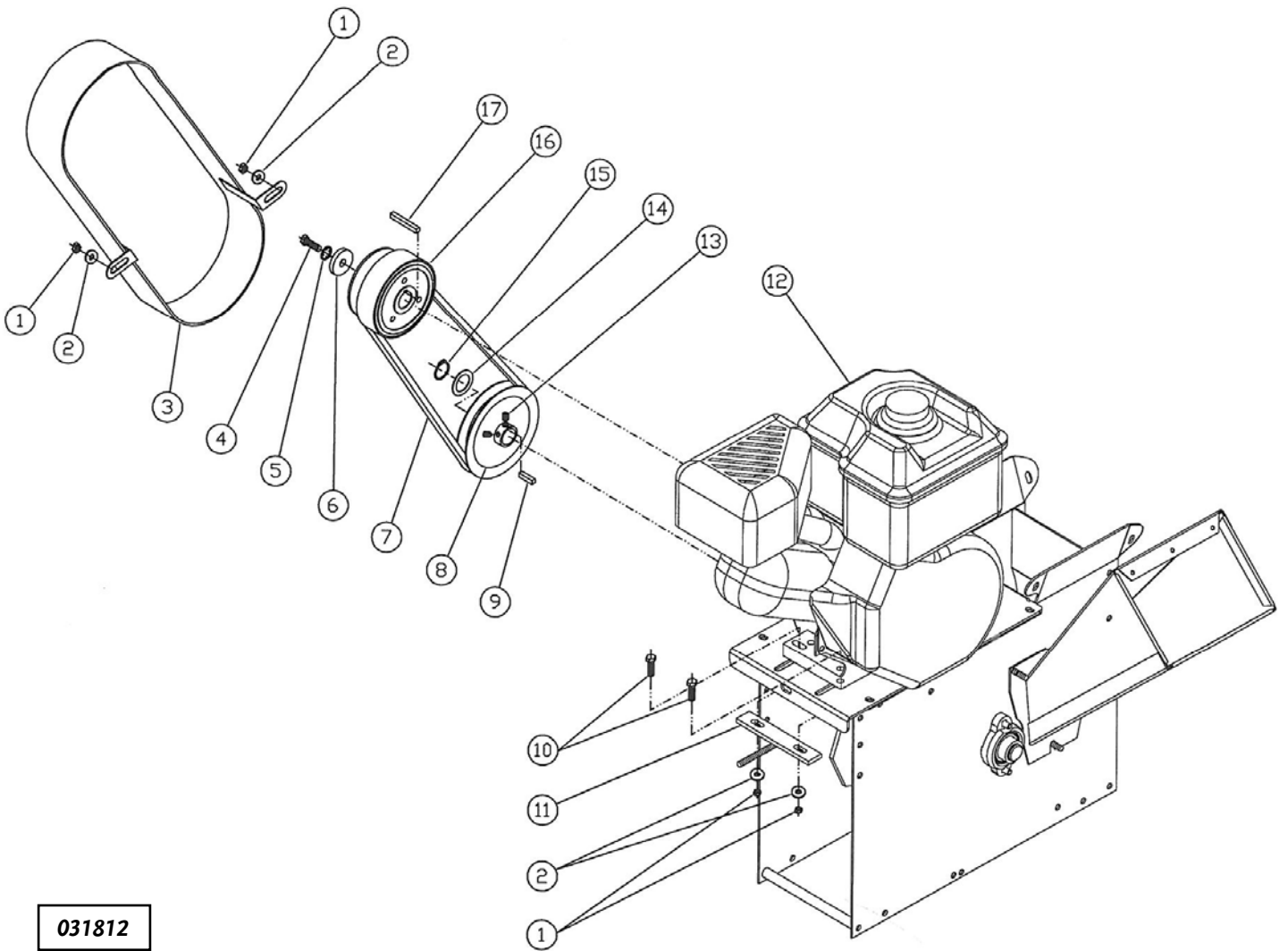

031812

## Parts List – DR HOPPERS AND SCREEN

**NOTE:** Part numbers listed are available through DR Power Equipment.

<u>Ref#</u>	<u>Part#</u>	<u>Description</u>	<u>Ref#</u>	<u>Part#</u>	<u>Description</u>
01	310361	Hopper Side	10	208471	Shield, Blowback
02	310341	Hopper Bottom	11	310441	Hopper, Chipper
03	310321	Hopper Top	12	202131	Screw, PHMS, 10-24 x 3/4"
04	145151	Washer, Flat, 5/16", USS	13	202121	Nut, Nylon Lock, 10-24
05	285901	Nut, Nylon Lock, 5/16-18	14	310451	Strip, Backer
06	227351	Pin, Cotter	15	167791	Bolt, HHCS, 5/16"-18 x 3/4"
07	249841	Screen	16	241621	Screw, Truss Head, 5/16-18 x 1/2"
08	305181	Plate, Baffle	17	289061	Nut, Nylon Lock, Thin, 5/16-18
09	223091	Rod, Screen and Baffle			

**Schematic – DR HOPPERS AND SCREEN**

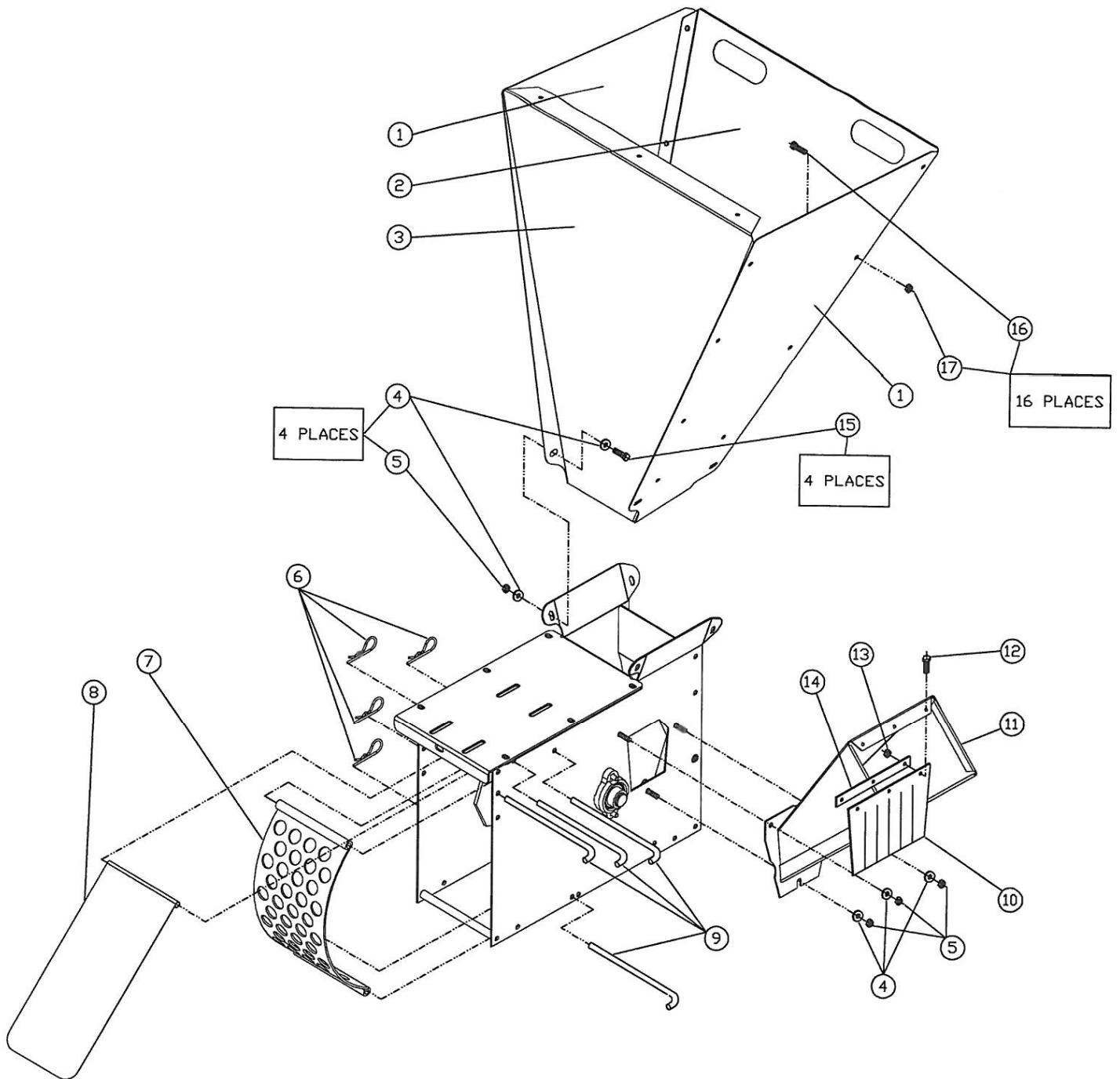

**031812**

## Parts List – DR SHREDDER HOPPER

**NOTE:** Part numbers listed are available through DR Power Equipment.

<u>Ref#</u>	<u>Part#</u>	<u>Description</u>	<u>Ref#</u>	<u>Part#</u>	<u>Description</u>
01	289061	Nut, Nylon Lock, Thin, 5/16-18	06	305191	Support, Blowback
02	310361	Hopper Side	07	241621	Screw, Truss Head, 5/16-18 x 1/2"
03	310321	Hopper Top	08	310341	Hopper Bottom
04	143401	Nut, Nylon Lock, 1/4-20	09	305201	Shield, Blowback
05	149651	Washer, Fender	10	119831	Bolt, HHCS, 1/4-20 x 3/4"

**Schematic – DR SHREDDER HOPPER**

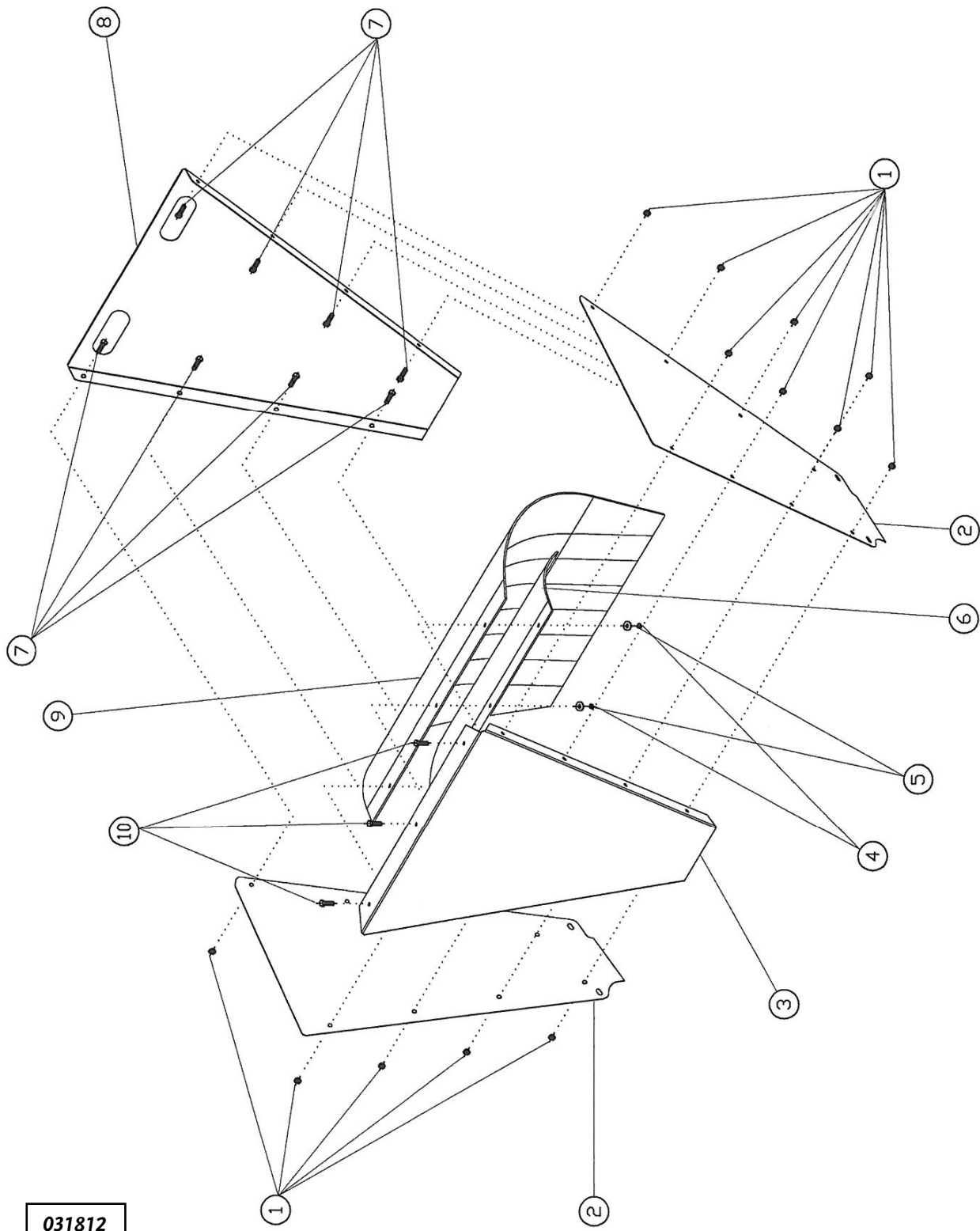

031812

## **Parts List – DR ROTOR ASSEMBLY**

**NOTE:** Part numbers listed are available through DR Power Equipment.

<u>Ref#</u>	<u>Part#</u>	<u>Description</u>	<u>Ref#</u>	<u>Part#</u>	<u>Description</u>
01	305221	Rotor Weldment	06	186171	Spacer, 7/8"
02	310421	Rod, Hammer	07	185791	Hammer
03	305151	Pin, Roll	08	285901	Nut, Nylon Lock, 5/16-18
04	186160	Spacer, 5/16"	09	305101	Knife
05	158531	Spacer, 5/8"	10	140671	Screw, FHSCS, 5/16-18 x 1"



**Schematic – DR ROTOR ASSEMBLY**

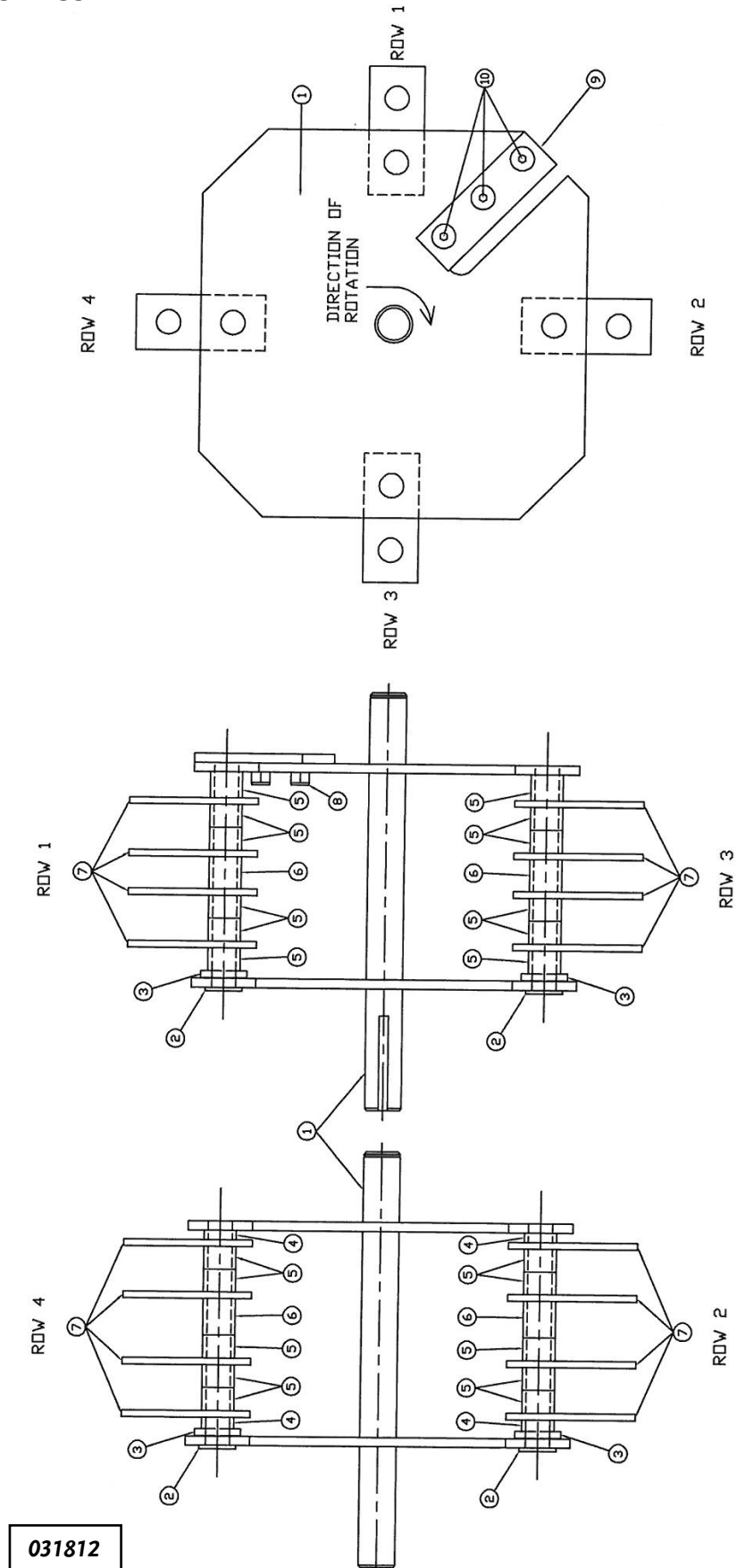

**Notes:**

**Notes:**

## Daily Checklist for the DR CHIPPER/SHREDDER

To help maintain your DR CHIPPER/SHREDDER for optimum performance, we recommend you follow this checklist each time you use your Chipper/Shredder.

---

### **WARNING**

Before performing any maintenance procedure or inspection, stop the Engine, wait five (5) minutes to allow all parts to cool. Disconnect the Spark Plug Wire, keeping it away from the Spark Plug.

---

- Check the Engine oil and Fuel Tank level.
- Check that Engine is clean of debris.
- Inspect the Chipper/Hopper(s) for accumulated debris.
- Check the general condition of the Chipper/Shredder, e.g.; nuts, bolts, welds, etc.
- Check Belt for wear and/or stretching.
- Check Tire Pressure and wear.
- Check the Chipper Knife for tightness, nicks and wear.
- Check the Debris Guard for wear and damage.
- Remove any debris wrapped around the Hammer(s) Rotor.

## End of Season and Storage

---

### **WARNING**

Before performing any maintenance procedure or inspection, stop the Engine, wait five (5) minutes to allow all parts to cool. Disconnect the Spark Plug Wire, keeping it away from the Spark Plug.

---

- Change the Engine oil.
- Clean or replace the Air Filter.
- Check the Chipper Knife and Hammers for nicks and wear.
- Remove any debris wrapped around the Hammer Rotor.
- If your DR CHIPPER/SHREDDER will be idle for more than 30 days, we recommend using a gas stabilizer. This will prevent sediment from gumming up the Carburetor. If there is dirt or moisture in the gas or tank, remove it by draining the tank. Completely fill the tank with fresh, unleaded gas and add the appropriate amount of stabilizer or gasoline additive. Run the Engine for a short time to allow the additive to circulate. Close the Fuel Shut-Off Valve to prevent carburetor overflow and leakage.
- Clean the exterior of the unit to remove all dirt, grease, and any other foreign material. To prevent rust, touch up painted surfaces that have been scratched or chipped.
- Be sure all nuts, bolts, and screws are securely fastened.
- Inspect moving parts and the Drive Belt for damage and wear; replace if necessary.
- Remove the Spark Plug and pour about 1 ounce of motor oil into the Cylinder hole. Replace the Plug and crank the Engine over a couple of times using the Pull Cord. This will coat the piston and seat the valves to prevent moisture buildup.
- If possible, store the Chipper/Shredder in a dry, protected place. If it is necessary to store the machine outside, after the DR CHIPPER/SHREDDER has cooled, cover the machine with a suitable protective cover that does not retain moisture. Do not use plastic as this material cannot breathe; it also allows condensation to form, which will cause your machine to rust.



---

75 MEIGS ROAD, P.O. BOX 25, VERGENNES, VERMONT 05491