

TOW-BEHIND DR[®] FIELD and BRUSH MOWER

SAFETY & OPERATING INSTRUCTIONS



Serial No. _____

Order No. _____

Original Language

DR Power Equipment
Toll-free phone: 1-800-DR-OWNER (376-9637)
Fax: 1-802-877-1213
Website: www.DRpower.com

! WARNING

Read and understand this manual and all instructions before operating the TOW BEHIND DR FIELD and BRUSH MOWER.

Table of Contents

Chapter 1: General Safety Rules..... 4

Chapter 2: Setting Up The TOW-BEHIND DR FIELD and BRUSH MOWER..... 7

Chapter 3: Operating the TOW-BEHIND DR FIELD and BRUSH MOWER..... 12

Chapter 4: Maintaining the TOW-BEHIND DR FIELD and BRUSH MOWER 18

Chapter 5: Troubleshooting 24

Chapter 6: Parts Lists and Schematic Diagrams..... 26

Conventions used in this manual

⚠ WARNING

This indicates a hazardous situation, which, if not avoided, could result in death or serious injury.

⚠ CAUTION

This indicates a hazardous situation, which, if not avoided, could result in minor or moderate injury.

NOTICE

This information is important in the proper use of your machine. Failure to follow this instruction could result in damage to your machine or property.

Serial Number and Order Number

A Serial Number is used to identify your machine and is located on the Serial Number Label on your machine (**Figure 1**). An Order Number is used to check and maintain your order history and is located on the upper left portion of your packing slip. For your convenience and ready reference, enter the Serial Number and Order Number in the space provided on the front cover of this manual.

Additional Information and Potential Changes

DR Power Equipment reserves the right to discontinue, change, and improve its products at any time without notice or obligation to the purchaser. The descriptions and specifications contained in this manual were in effect at printing. Equipment described within this manual may be optional. Some illustrations may not be applicable to your machine.

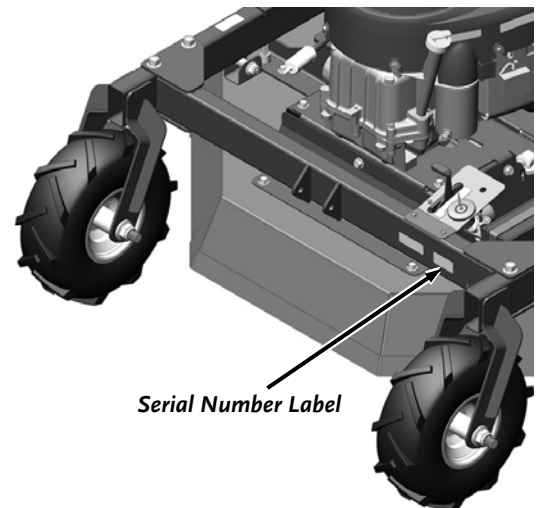

Figure 1

Chapter 1: General Safety Rules

WARNING

Read this Safety & Operating Instructions manual before you use the TOW BEHIND DR FIELD and BRUSH MOWER. Become familiar with the operation and service recommendations to ensure the best performance from your machine. If you have any questions or need assistance, please contact us at www.DRpower.com or call toll-free 1-800-DR-OWNER (376-9637) and one of our Technical Support Representatives will be happy to help you.

Labels

Your TOW BEHIND DR FIELD and BRUSH MOWER carries prominent labels as reminders for its proper and safe use. Shown below are copies of all the Safety and Information labels that appear on the equipment. Take a moment to study them and make a note of their location on your Mower as you set up and before you operate the unit. Replace damaged or missing safety and information labels immediately.



#13649



#13683

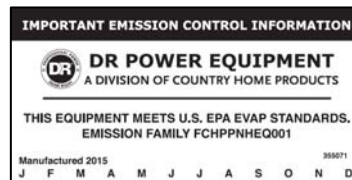

#35507



#13758



#36581



#36582



#37125



#36584



#37122



#36585

Protecting Yourself and Those around You

WARNING

This is a high-powered machine with moving parts operating at high speeds. Always take the following precautions when operating this machine:

- Always wear protective goggles or safety glasses with side shields.
 - We recommend wearing sturdy shoes with non-slip tread, long pants, and gloves while using this machine. Be sure the gloves fit properly and do not have loose cuffs or drawstrings.
 - Use ear protectors or ear plugs.
 - Allow only responsible adults who are familiar with these safety rules and operating instructions to use your DR FIELD and BRUSH MOWER.
 - Keep your hands and feet away from the blades, belt, pulley, and concealed areas while the engine is running.
 - Keep people and pets away from your machine and out of the work area at all times. Disengage the blade and stop the engine if a person or pet is within 100 feet of the machine.
 - Children are often attracted to the machine and the mowing activity. Never assume that children will remain where you last saw them.
 - Never allow people to ride on the mower.
 - Before mowing, clear the area of objects such as rocks, toys, wire, bones, sticks, etc.
 - Never remove or alter standard parts or add anything to the DR FIELD and BRUSH MOWER, especially all shields and guards.
 - Before and while moving backwards, look behind, and down for small children.
 - Use extra care when approaching blind corners, shrubs, trees, or other objects that may obscure your vision.
-

Safety with Gasoline - Powered Machines

WARNING

Gasoline is a highly flammable liquid that gives off flammable vapor that can be ignited and cause a fire or explosion. Always follow these precautions:

- Never run the engine in an enclosed area or without proper ventilation as the exhaust contains carbon monoxide, an odorless, tasteless, and poisonous gas.
 - Store all fuel and oil in containers specifically designed and approved for this purpose. Keep away from heat and open flame and out of the reach of children.
 - Replace rubber fuel lines and grommets when worn or damaged or after 5 years of use, whichever comes first.
 - Fill the gasoline tank outdoors with the engine off and after the engine has cooled completely. Don't handle gasoline if you or anyone nearby is smoking.
 - If you spill gasoline do not start the engine. Move the machine away from the area until the gas vapors have dissipated.
 - Before performing engine maintenance or repairs, shut down the engine, disconnect the spark plug wire, and wait 5 minutes for the engine to cool.
 - Never change the engine governor settings or modify the engine speed.
 - Never check for an ignition spark with the spark plug or spark plug wire(s) removed. Always use an approved spark tester.
 - Never tamper with safety devices. Regularly check their proper operation.
 - Allow the engine to cool completely before storing in any enclosed area.
 - Keep combustible substances away from the engine when it is hot. Never cover the machine while the muffler is still hot.
 - To reduce fire hazard, keep the engine and muffler free of debris build-up.
 - Do not operate the engine with the air cleaner or the carburetor air intake cover removed.
 - Do not use flammable solutions to clean the air filter.
 - Never operate the engine without the muffler and deflector, if so equipped. Inspect the muffler and deflector periodically and replace if necessary.
 - The muffler and engine become very hot and can cause a severe burn. Do not touch.
-

Slope Operation

WARNING

Use of machinery on slopes is a major factor in outdoor power equipment accidents. All slopes require caution. If you feel uneasy on a slope, do not mow it. Always take the following precautions when using this machine on slopes:

- Operate the machine up and down the face of slopes. Exercise extreme caution when changing direction on slopes.
- Never operate near drop-offs, ditches, or embankments or on slopes greater than 20 degrees.
- Never operate on wet or slippery slopes.
- Never park the tow vehicle on a steep grade or slope.

General Safety

WARNING

Safe operation of the TOW-BEHIND DR FIELD and BRUSH MOWER is necessary to prevent death or serious injury. Always take the following precautions when operating this machine:

- The TOW-BEHIND DR FIELD and BRUSH MOWER is designed to mow grass and brush. Do not use it for any other purpose.
- Always mount the remote control (if supplied) within easy reach of the operator's position.
- If the machine makes an unusual noise or vibration or if there are obstructions underneath the machine, shut off the tow vehicle and the DR FIELD and BRUSH MOWER engines. Wait five (5) minutes for the engine to cool. Disconnect the spark plug wire(s) and then inspect the machine for clogs or loose parts. Clear any obstructions and repair and/or replace damaged parts.
- The mower blades are sharp. Wrap the blades or wear gloves and use extra caution when servicing.
- Always keep the machine in good, safe operating condition. Always make certain nuts and bolts are tight. Do not use substitute hardware.
- Use the TOW-BEHIND DR FIELD and BRUSH MOWER only in daylight.
- Always give undivided attention to the machine and your surroundings. Watch for traffic when mowing near roadways.
- Disengage the mower blades and exercise extreme caution when on or crossing drives, walks, or roads.
- If leaving the machine, shift the tow vehicle into neutral and set the parking brake; turn off the tow vehicle engine and remove its key. Turn off the DR FIELD and BRUSH MOWER engine and remove its key.
- Do not operate the mower when under the influence of alcohol, drugs, or medication.

California Proposition 65

WARNING

California Proposition 65:

- Engine exhaust and some of its constituents are known to the State of California to cause cancer, birth defects, and other reproductive harm.
- This product contains or emits chemicals known to the State of California to cause cancer, birth defects, and other reproductive harm.

A Note to All Users

Under California law, and the laws of some other states, you are not permitted to operate an internal combustion engine using hydrocarbon fuels without an engine spark arrester. This also applies to operation on US Forest Lands. All TOW-BEHIND DR® FIELD and BRUSH MOWERS shipped to California, New Mexico and Washington State are provided with spark arresters. Failure of the owner or operator to maintain this equipment in compliance with state regulations is a misdemeanor under California law and may be in violation of other state and/or federal regulations. Contact your State Park Association or the appropriate state organization for specific information in your area.

No list of warnings and cautions can be all-inclusive. If situations occur that are not covered by this manual, the operator must apply common sense and operate this TOW-BEHIND DR FIELD and BRUSH MOWER in a safe manner. Contact us at www.DRpower.com or call 1-800-DR-OWNER (376-9637) for assistance.

Chapter 2: Setting Up The TOW-BEHIND DR FIELD and BRUSH MOWER

It may be helpful to familiarize yourself with the controls and features of your TOW-BEHIND DR FIELD and BRUSH MOWER by reviewing **Figure 2** before beginning these procedures. If you have any questions at all, please feel free to contact us at www.DRpower.com.

TOW-BEHIND DR FIELD and BRUSH MOWER Controls and Features (Pro and Pro-XL Models)

NOTE: The model shown in Figure 1 may look slightly different from your machine.

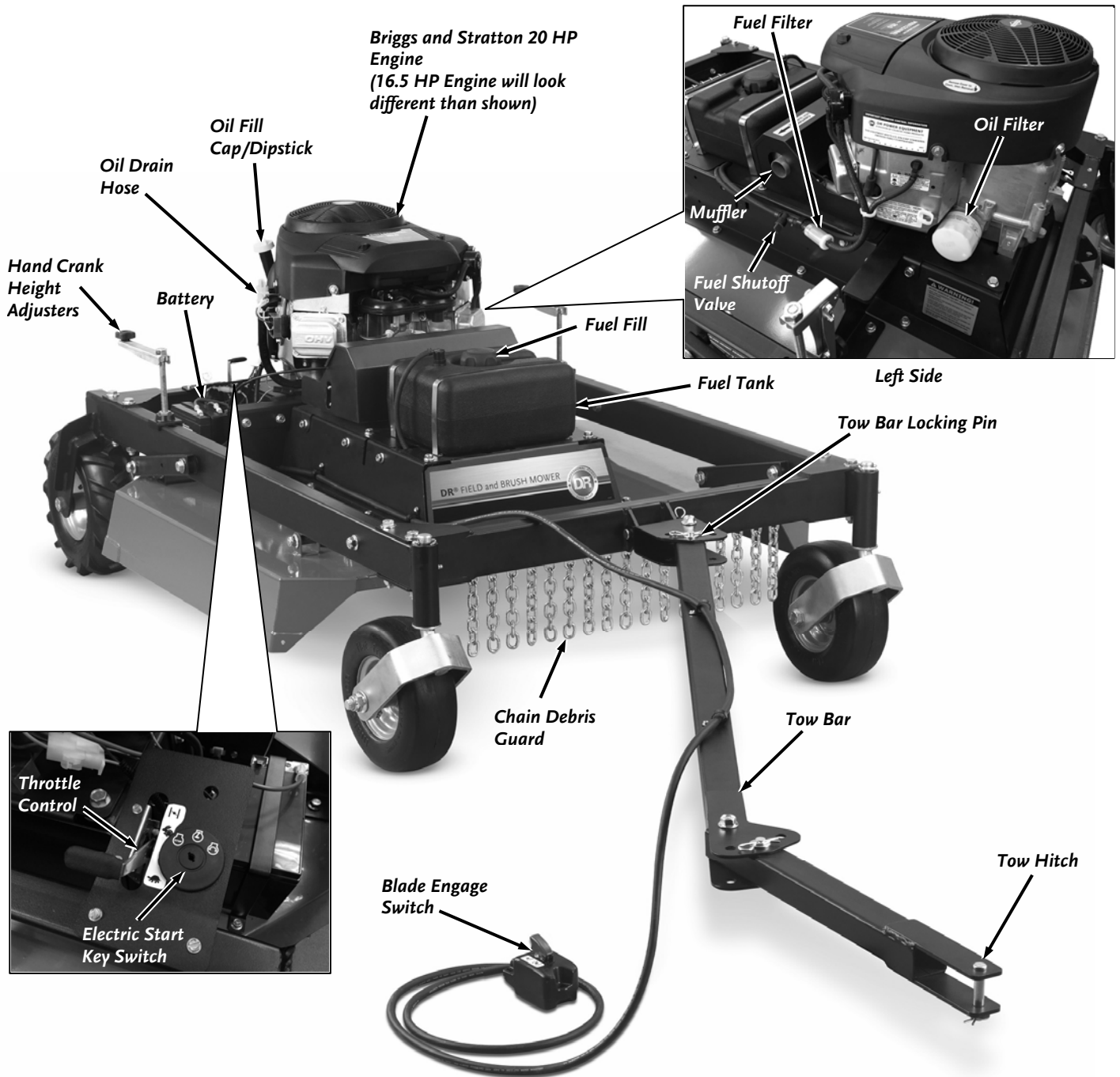

Figure 2

Specifications

	16.5 HP Pro Model	20 HP Pro-XL Model
Engine	See your Engine Manual for oil capacity and other Engine specifications.	See your Engine Manual for oil capacity and other Engine specifications.
Starting System	Electric Start	Electric Start
Fuel Tank	2.5 Gal. (9.46 L), Gasoline, Unleaded	2.5 Gal. (9.46 L), Gasoline, Unleaded
Battery	9Ah	9Ah
Wheels	Front: 11 X 4-5, Flat Free Rear: 13 x 5-6, Lugged (with tube)	Front: 11 X 4-5, Flat Free Rear: 13 x 5-6, Lugged (with tube)
Tether Length	14'-5"	14'-5"
Distance From Centerline To Outer Cutting Edge	68" - full offset 49.5" - mid offset	68" - full offset 49.5" - mid offset
Number of Offset Positions	5	5
Adjustable Cutting Height	From 4"min. to 7-1/2" max.	From 4"min. to 7-1/2" max.
Cutting Width	44"	44"
Cutting Capacity	4' high grass, 8'-high weeds & brush, 3" thick saplings	6' high grass, 8'-high weeds & brush, 3" thick saplings
Blade Tip Speed	18,500 - 19,000 ft/min	18,500 - 19,000 ft/min
Blades	Break Away/Swing, Air Tipped	Break Away/Swing, Air Tipped
Deck	12 GA Welded Steel	12 GA Welded Steel
Discharge	Rear	Rear
Spindle	1-3/8" Dia. Shaft with 2 Sealed 30 mm Bearings	1-3/8" Dia. Shaft with 2 Sealed 30 mm Bearings
Belt	B49	B49
Electric Clutch	75 ft-lb	95 ft-lb
Fuses	20 AMP Type AGC Fuse (Engine Alternator Circuit) 7 AMP Type AGC Fuse (Clutch Circuit)	20 AMP Type AGC Fuse (Engine Alternator Circuit) 7 AMP Type AGC Fuse (Clutch Circuit)
Max Speed Mow/Tow	5mph	5mph
Tongue Weight	10 lbs.	10 lbs.
Machine Dimensions	146" L x 46.5" W x 29.5" T	146" L x 46.5" W x 32.5" T
Machine Weight	358 lbs.	401 lbs.

Assembling the TOW-BEHIND DR FIELD and BRUSH MOWER

Hardware Supplied in Product Package (Figure 3 and Table below):

Item #	Part #	Description	Qty
1	18737	Pin, Clevis, 1/2" OD X 4.5" LG	1
2	25549	Pin, Clevis, 1/2" X 2-1/2", TRT	3
3	15720	Key, Ignition Switch	2
4	23499	Washer, SAE Flat, 1/2", ZP	4
5	16003	Pin, Hair, 1/2" To 9/16", .12" Wire	4

Compare the hardware of the Product Package with the "Parts Supplied" list above. If you have any questions please contact us at www.DRpower.com.

Attaching the Tow Bar to the Push Bar

The Tow Bar can be installed for offsetting to the right or left depending on which side of the Tow Vehicle you choose to mow. See section "Offset Mowing" in Chapter 3 to determine how the Tow Bar should be installed for your needs. The following steps describe installing the Offset Bracket to allow offsetting to the right side of the Tow Vehicle.

1. Secure the Offset Bracket to the Push Bar in the configuration shown (for right side offset) using the 4.5" long Clevis Pin, Washer, and Hair Pin (Figure 4).
2. Align the Tow Bar so it is pointed straight out from the Mower and install a Clevis Pin, Washer, and Hair Pin in the Offset Bracket to lock the Tow Bar in position.

! WARNING

Always install the Clevis Pins from the bottom with the Washers and Hair Pins on top to prevent the Hair Pin from being pulled out by tall grass or bushes.

3. Align the Tow Bar Extension with the Tow Bar and install a Clevis Pin, Washer, and Hair Pin in the Tow Bar to lock the Tow Bar Extension in place (Figure 5).

Connecting the Remote Control

Tools Needed:

- Wire Cutters

Note: An optional UTV Extension Kit is available to give you more mounting options for your machine by extending the Remote Control Wire Harness. Visit our website at www.DRpower.com to order Kit # 36593.

1. Use Wire Cutters to cut the Cable Tie that is securing the Remote Control Cable to the Frame for shipping.
2. Pull the Connector from the Blade Engage/Disengage Remote Control (Figure 6).

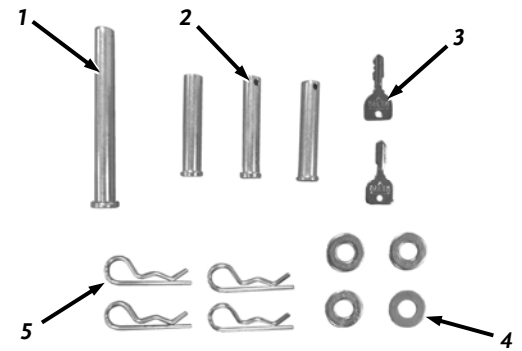

Figure 3

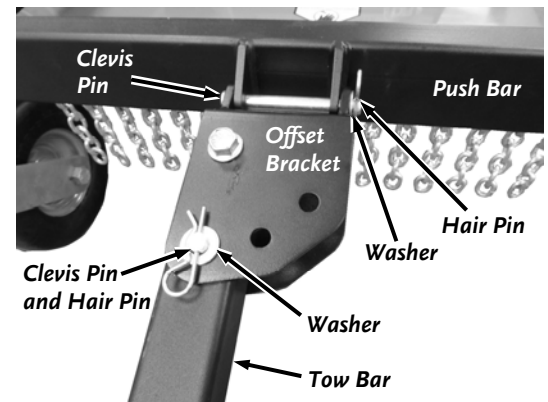

Figure 4

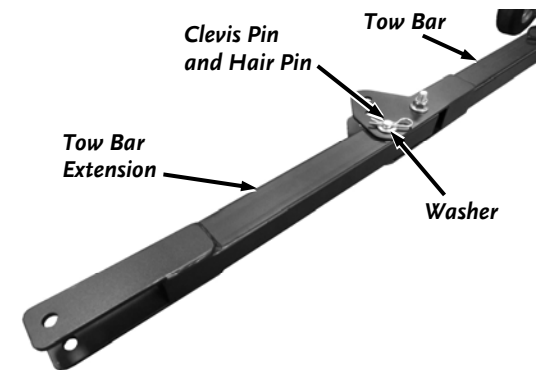

Figure 5

Blade Engage/Disengage Remote Control

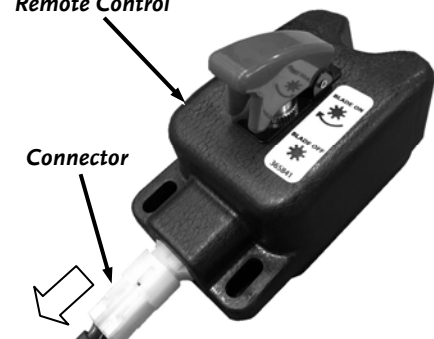

Figure 6

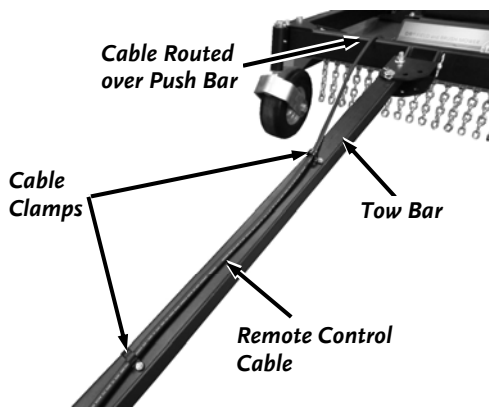

Figure 7

3. Position the Remote Control Cable over the Push Bar and insert the Connector through the Cable Clamps on the Tow Bar (**Figure 7**).
4. Plug the Connector into the Blade Engage/Disengage Remote Control (**Figure 6**).

Adding Oil and Gasoline

Tip: To avoid confusion, we recommend leaving the caps on the Fuel and Oil Fills until you are ready to pour either gasoline or oil into the correct Fill.

Engine Oil and Fuel Capacities		
	Oil (SAE 30 HD)	Fuel (Unleaded)
Briggs and Stratton – 16.5 HP	48 oz.	2.5 Gal (9.46 L)
Briggs and Stratton – 20 HP	64 oz. w/Filter	2.5 Gal (9.46 L)

Note: Use only SAE 30 HD (High Detergent) oil. Other types of oil could cause problems with the operation of your machine. Please refer to your Engine Owner's Manual for detailed oil information.

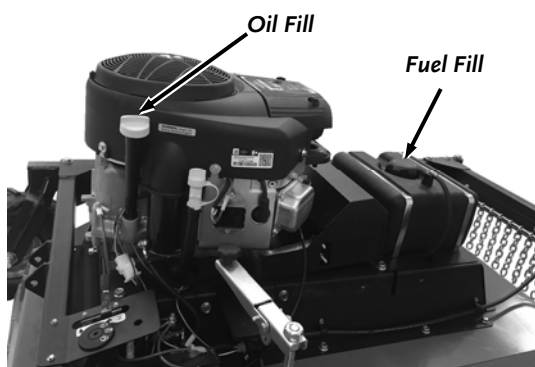

Figure 8

NOTICE

- You must add oil before starting the engine. This machine is shipped without oil. Traces of oil may be in the reservoir from factory testing, but **YOU MUST ADD OIL BEFORE STARTING THE ENGINE**. Fill the reservoir slowly, checking the level frequently to avoid overfilling.
- To get an accurate reading when checking the oil level:
 - The machine should be on a level surface.
 - The dipstick **SHOULD** be screwed down.

Note: See the Engine Owner's Manual for more detailed information.

1. Place the machine on a level surface and remove the Oil Fill Cap/Dipstick (**Figure 8**).
2. Initially add 32 oz. of SAE 30 High Detergent oil (recommended by the Engine Manufacturer) into the Oil Fill and wait one minute for the oil to settle.
3. Replace the Dipstick fully and then remove it to check the oil level. Continue adding a few ounces of oil at a time, rechecking the Dipstick until the oil reaches the fill mark. Be careful not to overfill.
4. Replace the Dipstick and turn it a quarter turn clockwise to lock it fully into position.
5. Remove the Fuel Cap and fill the gas tank to within 1-1/2" below top of fill neck (to allow for fuel expansion) with fresh, unleaded gas. Replace the Fuel Cap when finished.

Connecting the Battery Wire

We ship all Electric-Starting machines with the green negative (ground) Battery Wire disconnected. This prevents the Battery from discharging during shipment. Before using your TOW-BEHIND DR FIELD and BRUSH MOWER, you must connect the green negative Battery Wire.

1. Push the negative Wire Connector fully onto the negative terminal of the Battery (**Figure 9**).

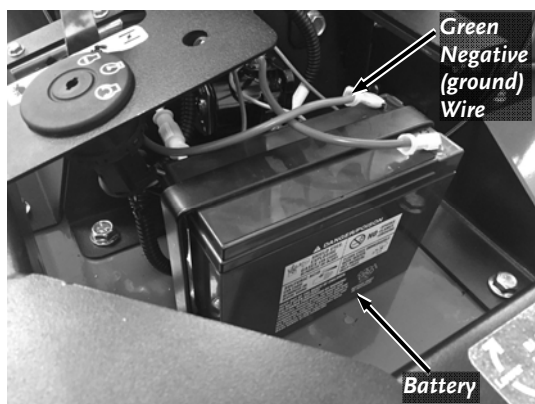

Figure 9

Connecting the TOW-BEHIND DR FIELD and BRUSH MOWER to your Tow Vehicle

The Pin type Hitch that comes standard on the TOW-BEHIND DR FIELD and BRUSH MOWER Tow Bar is quick and easy to attach to Tow Vehicles with a hole in the Hitch Plate. A ball Hitch Kit is also available if you would prefer attachment to a 2" Ball on the Tow vehicle. Visit our website at www.DRpower.com to order Ball Hitch Kit #36578.

1. Move your Tow Vehicle to a flat area and set the Parking Brake.
2. Align the Tow Hitch to the hole in the center of your Hitch Plate with the top portion of the Tow Hitch above the Hitch Plate and the bottom portion below (*Figure 10*).
3. Secure the Hitch with the Clevis Pin and Hair Pin.

Attaching the Blade Engage/Disengage Remote Control

NOTICE

Be sure to route the Remote Control Cable away from the muffler of the tow vehicle to prevent damage to the Cable.

1. Position the Blade Engage/Disengage Remote Control on your Tow Vehicle within reach of the seated Tow Vehicle driver (*Figure 11a and 11b*).
2. Secure the Remote Control to a fixed object on your Tow Vehicle using the mounting holes at either end of the Control Box with Cable Ties or equivalent.

Tip: Mounting the Blade Engage/Disengage Remote Control on the side of the Tow Vehicle that the mower is offset will make it easier to access while observing the mower.

Checking the Rear Tire Pressure

Tools Needed:

- Tire Pressure Gauge
- Air Compressor

1. Remove the Valve Stem Protective Cap (*Figure 12*) and check the tire pressure with a Tire Pressure Gauge.
2. Compare the tire pressure reading from step 1 with the manufacturer's recommended tire pressure stamped on the side of the tire.
3. If the pressure is too low, add air through the Valve Stem with an air hose.
4. Replace the Valve Stem Protective Cap when finished.

⚠ WARNING

Do not over inflate the tires. Inflate to the manufacturers recommended pressure found on the tires.

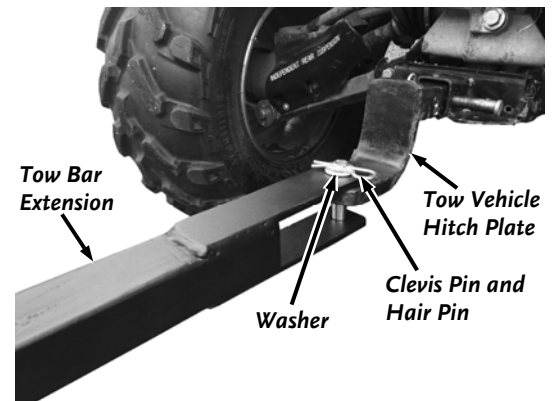

Figure 10

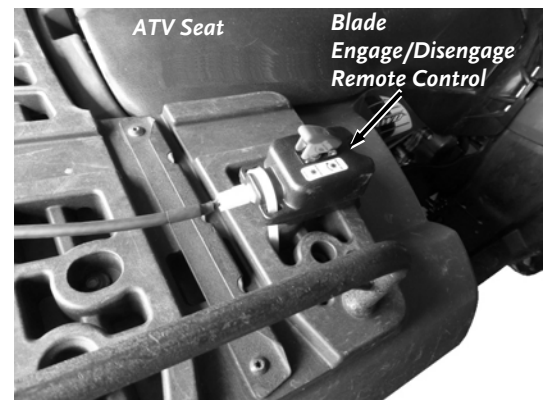

Figure 11a: ATV Mounting

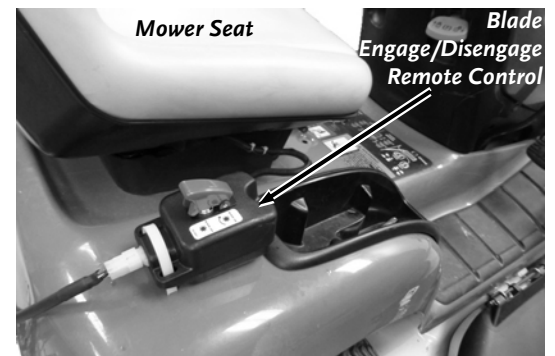

Figure 11b: Mower Mounting



Figure 12

Chapter 3: Operating the TOW-BEHIND DR FIELD and BRUSH MOWER

This chapter covers the procedures for starting and stopping your new TOW-BEHIND DR FIELD and BRUSH MOWER and discusses basic operation features. You may find it helpful to review the TOW-BEHIND DR FIELD and BRUSH MOWER Controls and Features on page 6 before reading this chapter.

WARNING

- This machine is designed for cutting grass and brush. Never use this machine for any other purpose as it could cause serious injury.
- Contact with internal rotating parts will cause serious personal injury. Never put hands, face, feet, or clothing under the deck or near the discharge area with the engine running.
- Before performing any maintenance procedure or inspection, stop the engine and wait five (5) minutes to allow all parts to stop and cool. Disconnect the spark plug wire(s) keeping it away from the spark plug(s).

Operating Parameters

We recommend a few types of Tow Vehicles for the TOW-BEHIND DR FIELD and BRUSH MOWER. The Tow Vehicle may be either 2 or 4 wheel drive, but some vehicle types are not suitable for rough, hilly terrain or heavy brush conditions. See the Tow Vehicle Restrictions section below.

- ATV
- Lawn/Garden Tractor (17 HP and above and weighing at least 500 pounds)
- Riding Lawn Mower (14 HP and above and weighing at least 400 pounds)
- Utility Vehicle
- Compact or Sub-Compact Tractor

Tow Vehicle Restrictions:

- You must be able to secure the Blade Engage/Disengage Remote Control of the TOW-BEHIND DR FIELD and BRUSH MOWER within easy reach of the driver seated on the Tow Vehicle.
- Riding Lawn Mowers with Engines under 17 HP and weighing less than 500 pounds are not suitable for use on slopes greater than 5°.
- Never operate your TOW-BEHIND DR FIELD and BRUSH MOWER on slopes greater than 20° using any type of Tow Vehicle.
- If your Tow Vehicle will not travel by itself over the terrain you plan to use it with the TOW-BEHIND DR FIELD and BRUSH MOWER, then it will not be suitable as a Tow Vehicle over that terrain.

Tip: Riding Lawn Mowers will work best as a Tow Vehicle with their cutting deck removed.

CAUTION

- We do not recommend driving over 5 mph on flat terrain and over 4 mph on rough terrain while operating your TOW-BEHIND DR FIELD and BRUSH MOWER.
- Never use a truck (2 or 4wd) or jeep to operate the TOW-BEHIND DR FIELD and BRUSH MOWER. It would be difficult to see and you cannot operate the mower controls from these types of tow vehicles. Using these vehicles will void the TOW-BEHIND DR FIELD and BRUSH MOWER warranty.

Before Starting the Engine





! WARNING

Inspect the area where you will be working. The site must be free of potentially hazardous obstacles such as glass, large stones, sticks, wire, rope, and string-like materials. Make sure there are no people or animals in the area around the TOW-BEHIND DR FIELD and BRUSH MOWER.

1. Check the oil level every time you use the machine. See your Engine Owner's Manual.
2. Check the gasoline level.
3. Open the Fuel Shut-Off Valve on the left hand side of the Mower (**Figure 13**).
4. Make sure the Blade Control Safety Cover is pushed down to the disengaged position (**Figure 14**).

Note: The Blade Switch Safety Cover must be pushed down or the Engine will not start.



Starting

1. Ensure the Blade Switch Safety Cover is down (**Figure 14**).
2. When starting a cold Engine, push the Throttle Control Lever up to the Choke  position (**Figure 15**). When starting an already warm Engine, push the Throttle Control Lever to the Run  position.
3. Turn the Key Switch to the Start  position until the Engine starts, then release. The Key will snap back to the center On  position and the Engine will continue to run.
4. As the Engine warms up, slowly adjust the Throttle to the Run  position. Wait until the Engine runs smoothly before each Throttle adjustment. For maximum performance, operate the Engine with the Throttle in the Run position.

Stopping the Engine

NOTICE

Never stop the engine by moving the throttle control lever to the choke position. This could cause an engine backfire resulting in engine damage.

1. Disengage the Blades by pushing the Blade Control Safety Cover down (**Figure 14**).
2. Move the Throttle Control Lever all the way down to the Idle  position and turn the Key to Stop  (**Figure 15**).
3. Remove the Key for safety.

Note: Close the Fuel Shut-Off Valve when transporting or storing the TOW-BEHIND DR FIELD and BRUSH MOWER (**Figure 13**).

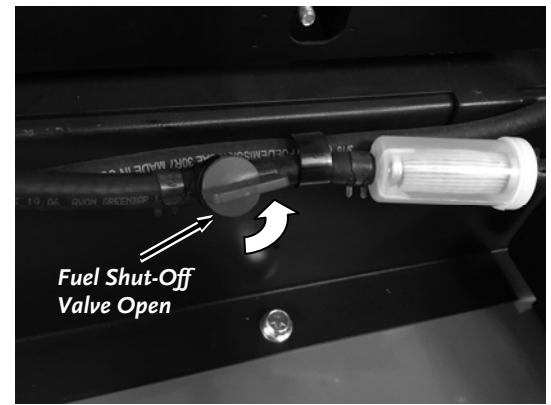

Figure 13



Figure 14

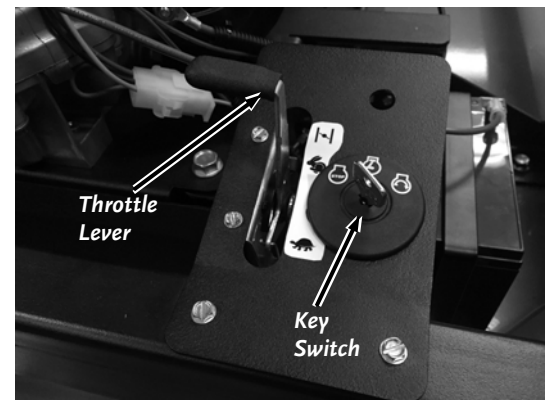

Figure 15

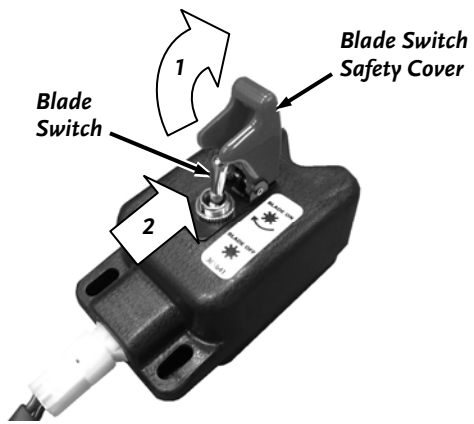

Figure 16

Engaging the Blades

1. Engage the Blades by pulling up on the Blade Control Safety Cover and pushing forward on the Blade Control Switch (**Figure 16**).

Stopping the Blades

1. Push down on the Blade Control Safety Cover (**Figure 14**).

Adjusting the Mower Deck Height

! WARNING

- Shut off the engine before adjusting the deck height or serious injury may result. The blades could sever your foot if it goes under the deck with the engine running.
- Never get off the Tow Vehicle without first stopping the blades and shutting off the Tow Vehicle engine.

! CAUTION

Keep your foot clear of the mower deck when adjusting the height. You could pinch your foot if it is under the deck.

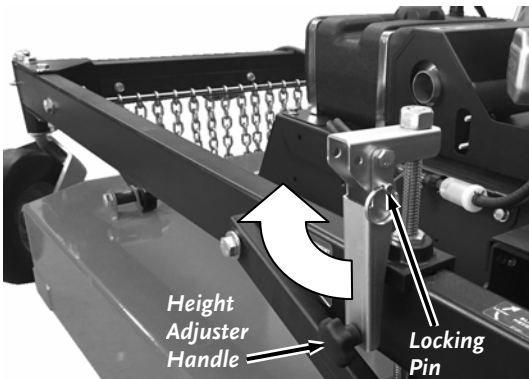

Figure 17

Note: The TOW-BEHIND DR FIELD and BRUSH MOWER Deck cutting Height ranges from a minimum of 4" to a maximum of 7.5".

1. Remove the Locking Pin from the Height Adjuster (**Figure 17**).
2. Lift the Handle up to the operating position and re-install the Locking Pin (**Figure 18**).
3. Repeat Steps 1 and 2 for the Height Adjuster on the opposite side.

Note: Rotating the Height Adjusters Clockwise will lower the Mower Deck. Rotating the Height Adjusters Counter Clockwise will raise the Mower Deck. Ten full rotations equal 1" of height change.

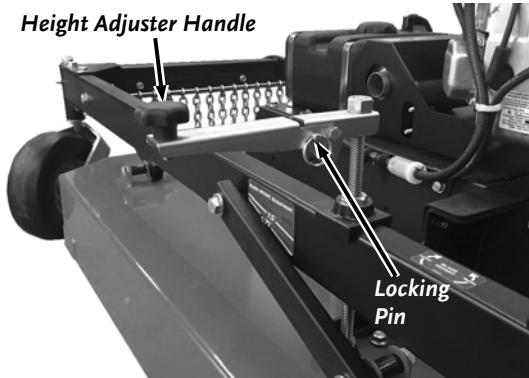

Figure 18

4. Rotate both Height Adjusters in the desired direction, switching sides about every ten full turns, until the top of the Sway Brace is aligned with the desired cutting height lines on the Height Adjust label. (**Figure 19**).
5. After the height is set the same on both sides of the machine, rotate the Handle to the inside of the Frame, pull the Locking Pin, fold the Handle down and insert the Locking Pin to secure the Handle in the down position.

NOTICE

The Height Adjust Handle should always be pinned in the down position for mowing. This prevents the Height Adjuster from rotating and lowering Deck during use.

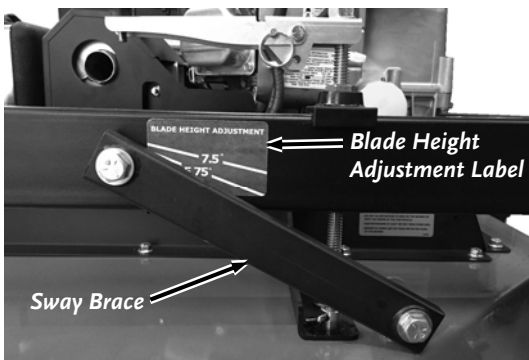

Figure 19

Offset Mowing

The Tow Bar allows you to offset the cutting path of the TOW-BEHIND DR FIELD and BRUSH MOWER up to 46" from the center of the Tow Vehicle. The provided offset positions are "No Offset" (in line with Tow Vehicle), "Middle Offset" (27-1/2" from center of Tow Vehicle) or "Full Offset" (46" from the center of the Tow Vehicle). Offset mowing allows you to mow closer to equipment, trees, and fences while the Tow Vehicle stays at a safer distance. It also allows you to drive in an area already cut and not through grass and brush that hasn't been cut yet.

See the section "Configuring the Tow Bar Offset Direction" on the next page to allow offsetting the Mower to the left side of the Tow Vehicle.

CAUTION

When performing offset mowing, always be sure that the Tow Bar offset and the Tow Bar Extension offset match (**Figure 20**). This ensures the Tow-Behind DR Field and Brush Mower will track parallel to the tow vehicle path.

Offsetting the Tow Bar:

1. Remove the Hair Pin, Washer, and Clevis Pin that secures the Tow Bar in the Offset Bracket (**Figure 21**).
2. Rotate the Tow bar to the Desired Offset (No Offset, Middle Offset, or Full Offset).
3. Reinstall the Clevis Pin, Washer, and Hair Pin to Lock the Tow Bar in Place.

WARNING

Always install the Clevis Pins from the bottom with the Washers and Hair Pins on top to prevent the Hair Pin from being pulled out by tall grass or bushes.

Offsetting the Tow Bar Extension:

1. Remove the Hair Pin, Washer, and Clevis Pin that secures the Tow Bar Extension to the Tow Bar (**Figure 22**).
2. Rotate the Tow bar Extension so that the Offset angle is the same as at the Offset Bracket (No Offset, Middle Offset, or Full Offset).
3. Reinstall the Clevis Pin, Washer, and Hair Pin to Lock the Tow Bar Extension in Place.

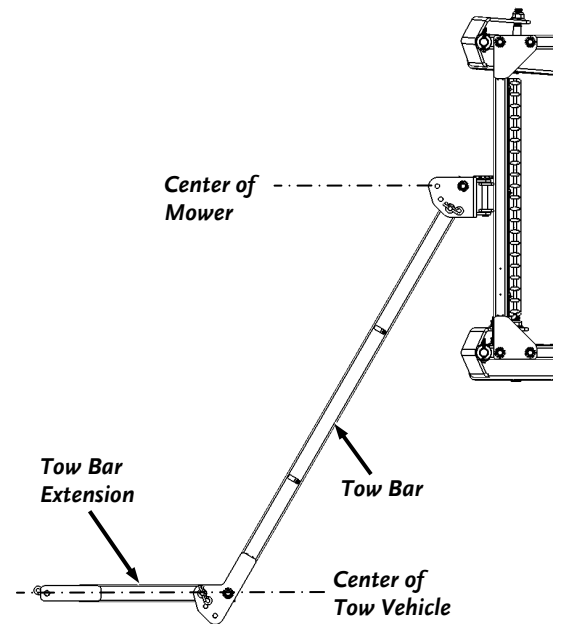

Figure 20: Full Offset Shown

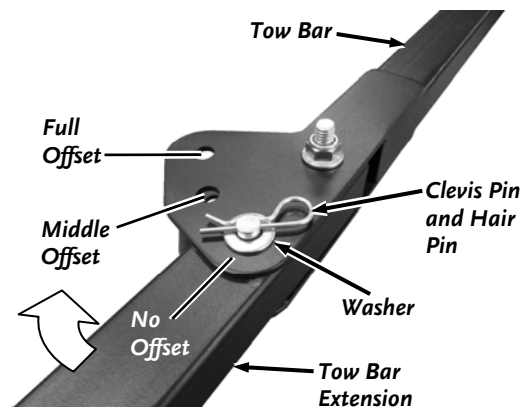

Figure 22

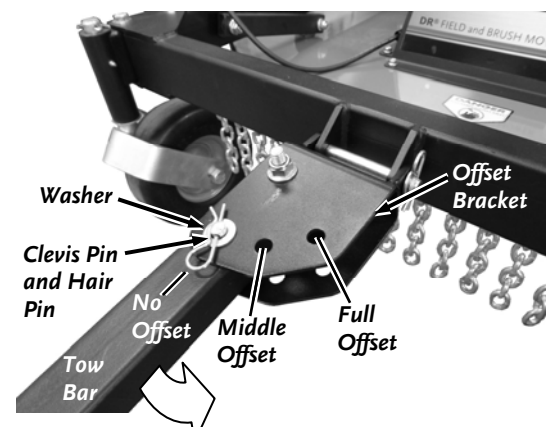

Figure 21

Blade Engage/Disengage
Remote Control

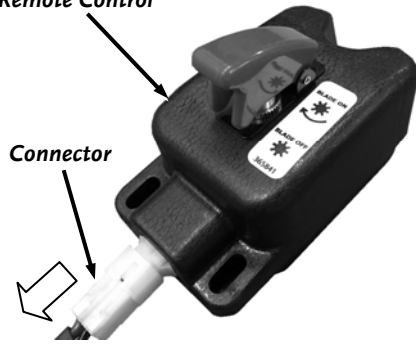

Figure 23

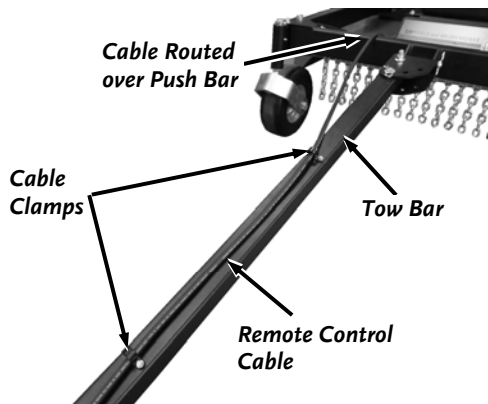

Figure 24

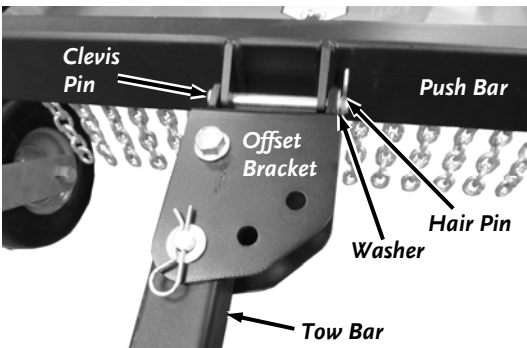

Figure 25

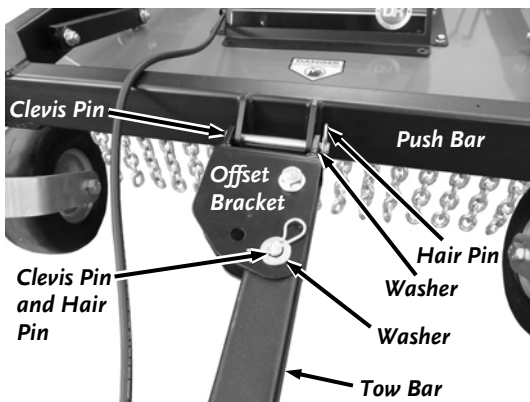

Figure 26

Changing the Tow Bar Offset Direction

The Tow Bar can be installed for offsetting to the right or left depending on which side of the tow vehicle you choose to mow. The following steps describe installing the Offset Bracket to allow offsetting to the left side of the Tow Vehicle.

Tools Needed:

- 5/16" Nut Driver

1. Remove the Connector from the Blade Engage/Disengage Remote Control (**Figure 23**).
2. Pull the Remote Control Cable from the Cable Clamps (**Figure 24**).
3. Remove the Cable Clamps from the Tow Bar using a 5/16" Nut Driver.
4. Support the Tow Bar as you remove the Hair Pin, Washer and Clevis Pin that secures the Offset Bracket to the Push Bar (**Figure 25**).
5. Turn the Tow Bar over to position the Offset Bracket for left side offset (**Figure 26**).
6. Reinstall the Offset Bracket to the Push Bar with the Hair Pin, Washer and Clevis Pin.
7. Install the Cable Clamps to the top of the Tow Bar using a 5/16" Nut Driver (**Figure 24**).
8. Position the Remote Control Cable over the push bar and insert the Connector through the Cable Clamps on the Tow Bar.
9. Plug the Connector into the Blade Engage/Disengage Remote Control (**Figure 23**).
10. Remove the Hair Pins, Washers and Clevis Pins that are at the Tow Bar and Tow Bar Extension offsets and reinstall with the Washers and Hair Pins on top.

! WARNING

Always install the Clevis Pins from the bottom with the Washers and Hair Pins on top to prevent the Hair Pin from being pulled out by tall grass or bushes.

11. To adjust the offset see section "Offset Mowing" on the previous page.

Slopes and Uneven Terrain

WARNING

- Check the owner's manual for your tow vehicle to determine its recommended towing capabilities on slopes.
 - When operating the TOW-BEHIND DR FIELD and BRUSH MOWER over uneven terrain or slopes, use extreme caution not to tip over the machine.
 - Never use the TOW-BEHIND DR FIELD and BRUSH MOWER on slopes greater than 20 degrees. Doing so could result in serious injury or damage to your machine.
 - If you have to mow on sloping terrain, mow up and down, never across the slope, for better control.
-

If the machine gets hung up

WARNING

- If you need to leave the tow vehicle to clear debris from the mower deck, set the parking brake and shut off the tow vehicle engine, disengage the mower blades, shut off the TOW-BEHIND DR FIELD and BRUSH MOWER engine and disconnect the spark plug wire(s).
 - Never touch the exhaust areas when reaching for the spark plugs; they may be very hot.
-
1. Disengage the Blades and STOP the Engine. NEVER try to free the machine from stumps or debris with the Blades engaged.
 2. Try driving over or backing away from the obstacle.

Cutting Brush and Saplings

- The cutting capacity is 3" saplings.
- When cutting woody material, small saplings, etc., allow the machine to ride up and over material slowly. Adjust your forward speed to varying conditions.
- After cutting brush, etc., you may want to mow over it again to remove any remaining branches. It works best to mow from the trunk end toward the top as brush lies on the ground.

Cutting Wet and Heavy Growth

- Avoid steep slopes and other slippery areas.
- Use a lower, slower speed when mowing in wet conditions.

Chapter 4: Maintaining the TOW-BEHIND DR FIELD and BRUSH MOWER

This chapter covers regular maintenance procedures that will ensure the best performance and long life of your TOW-BEHIND DR FIELD and BRUSH MOWER. For Engine maintenance, please refer to the Engine Owner's Manual that came with your machine. Service intervals listed in the checklist below supersede those listed in the Engine Owner's Manual.

WARNING

- When performing any adjustment or maintenance, you must first disengage the Blade, shut off the engine, wait five minutes to allow parts to cool and disconnect the spark plug wire(s), keeping it away from the spark plug(s).

Regular Maintenance Checklist

Note: Consider the service intervals shown as maximum under normal operating conditions. Increase frequencies under extremely dirty or dusty conditions.

PROCEDURE	BEFORE EACH USE	EVERY 25 HOURS	EVERY 100 HOURS
Check Engine Oil Level	▲		
Check General Condition, e.g. nuts, bolts, welds, etc.	▲		
Check the Blades Sharpness	▲		
Clean Engine Exterior & Cooling Fins	▲		
Check Cable connections		▲	
Check Tire Pressure of rear Wheels (psi on side of tire)		▲	
Change Engine Oil and Filter. Note: 1 st time after 5 hours		▲	
Replace Air Filter		▲	
Lubricate Wheel Bearings		▲	
Lubricate Height Adjustment Threads		▲	
Check Drive Belt Condition		▲	
Replace Spark Plug(s)			▲
Replace In-line Gas Filter			▲



Figure 27

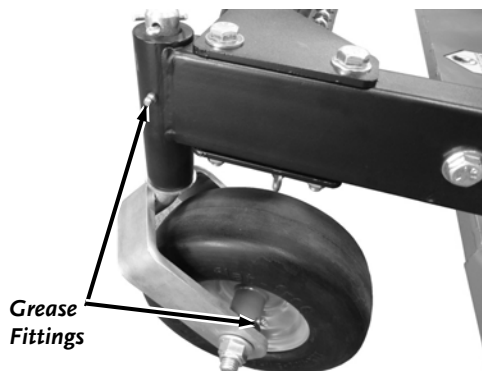

Figure 28

Lubrication

Tools and Supplies Needed:

- Grease gun with Multipurpose Automotive Grease
- Clean Rags

Lubricate Wheel Bearings and Casters:

- Clean the Grease Fitting with a clean Rag (**Figure 27 and 28**).
- Lubricate each Rear Wheel and Caster Shaft with Multipurpose Automotive Grease using a grease gun on the Grease Fitting.

Height Adjuster Threads

Tools and Supplies Needed:

- Wire Brush and Rags
- Super Lube

1. Raise the Deck to its highest position.
2. Clean any dirt or debris from the Height Adjuster threads with a Wire Brush and Rags (**Figure 29**).
3. Apply Super Lube to the full length of threads.
4. Lower the Deck to distribute the lubrication.

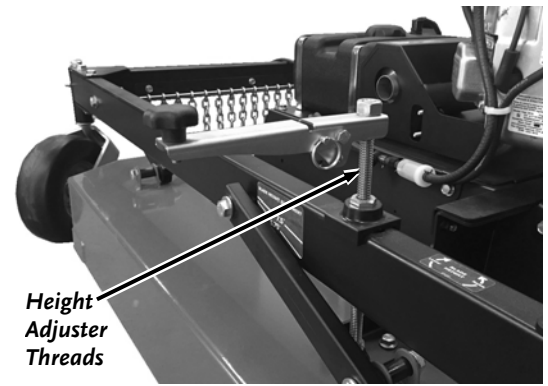

Figure 29

Removing and Replacing the Engine Oil and Filter

Note: Refer to the Engine Owner's manual for more detailed instructions for Engine maintenance. Drain the oil when the Engine is warm. Warm oil drains quickly and completely.

Tools and Supplies Needed:

- Oil Filter Wrench (available at local auto parts or hardware store)
- Rags and an approved container for used oil
- SAE 30 High Detergent Oil

1. Remove the Oil Fill Cap/Dipstick (**Figure 30**).
2. Turn the Oil Drain Cap a quarter turn counterclockwise and open the end of the Drain Hose Assembly.
3. Position an appropriate drain container near the Drain Hose.
4. Remove the Oil Drain Hose Assembly from the Bracket and lower the Cap end over the Container to drain.
5. The Engine Oil Filter is located on the side of the Engine (**Figure 31**). Using an Oil Filter Wrench, or grasping the Oil Filter firmly with your hand, unscrew the Oil Filter counterclockwise from the Engine. **BE SURE THAT THE OLD FILTER GASKET COMES OFF WITH THE FILTER.**
6. Wipe the mounting base for the Oil Filter with a clean cloth.
7. Apply a thin coat of clean motor oil to the new Oil Filter Gasket. **DO NOT USE GREASE OR USED OIL.**
8. Line up the threads carefully to avoid cross threading and screw the new Oil Filter on until the Filter Gasket contacts the base, and then tighten the Oil Filter 3/4 to 1 turn. **DO NOT OVER TIGHTEN.**
9. Mount the Oil Drain Hose Assembly onto the Bracket and replace the Oil Fill Cap.
10. Refill the oil by following the instructions in Chapter 2.

Note: Be sure to use environmentally safe disposal procedures in the disposing of the used oil.

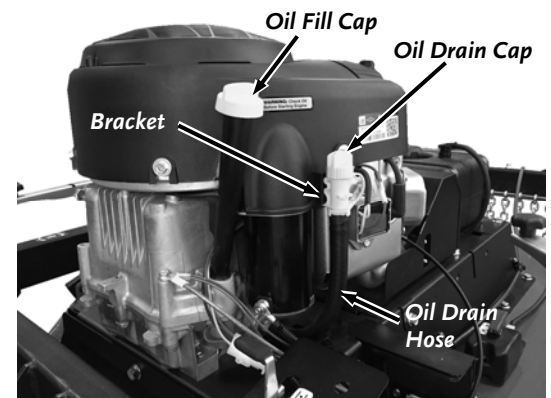

Figure 30



Figure 31

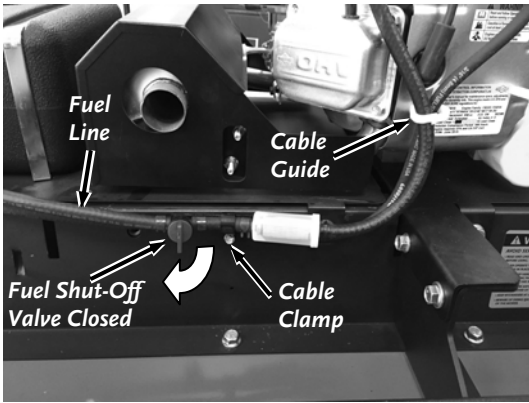

Figure 32

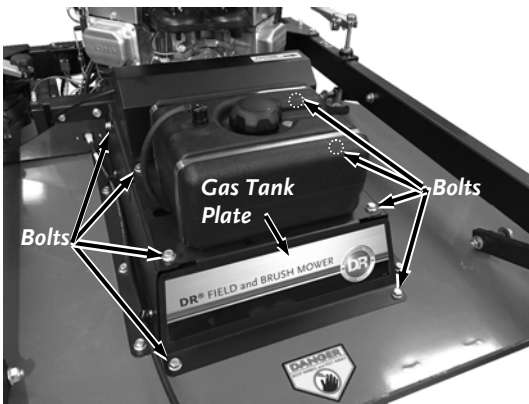

Figure 33

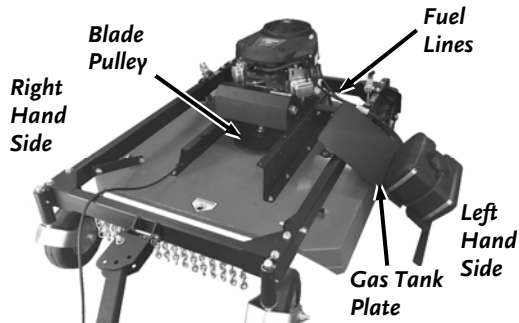

Figure 34

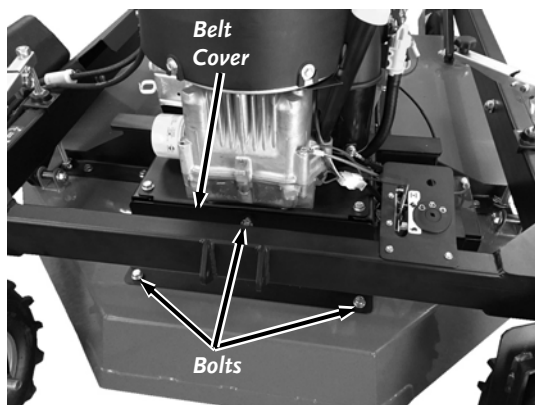

Figure 35

Removing and Replacing the Drive Belt

Tools Needed:

- 9/16" Wrench
- 5/16" Nut Driver

NOTICE

Use only DR belts on your machine. They have been thoroughly tested and proven for many hours of use.

Removing the Belt

1. Turn the Fuel Shut-Off Valve to the Closed position (**Figure 32**).
2. Using a 5/16" Nut Driver, Remove the Cable Clamp securing the Fuel and Vapor Lines.
3. Remove the Fuel and Vapor Lines from the Cable Guide on the Engine.
4. Using a 9/16" Wrench, Remove the eight bolts securing the Gas Tank Plate (**Figure 33**).

NOTICE

When moving the Gas Tank Plate, be careful not to stress the Fuel Lines because it could damage the Fuel Lines or Connections.

5. Carefully lift the Gas Tank Plate and position it on the Fuel Line side of the machine (left hand side) (**Figure 34**).

Note: It is helpful to lift the front of the Gas Plate up while pulling it from under the Muffler on the 20hp Models.

6. At the back of the machine, use a 9/16" Wrench to remove the three Bolts securing the Belt Cover and set the Belt Cover aside (**Figure 35**).
7. From the front of the machine where you removed the Gas Tank Plate, rotate the Blade Pulley Counter Clockwise as you roll the Drive Belt up and over the Blade Pulley (**Figure 36**).

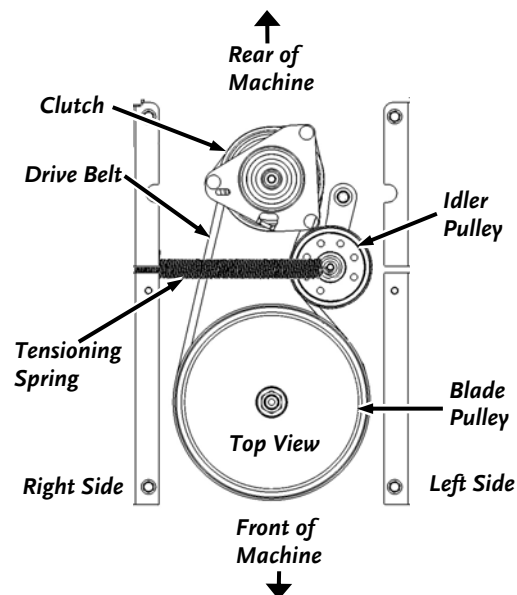

Figure 36

Note: It works best to roll the Belt off and onto the Blade Pulley on the opposite side of the Idler Pulley (right side of machine).

8. From the back of the Machine, Push the Idler Pulley away from the Drive Belt and pull the Drive Belt down to remove it from the Clutch.
9. Pull the Drive Belt out from the back of the machine.

Installing the Belt

1. From the back of the machine, insert the new Drive Belt under the Clutch (**Figure 36**).
2. Pull the Idler Pulley out and position the Drive Belt onto the Clutch.

Tip: Use your right hand to push the Idler Pulley while using your left hand to position the belt.

3. From the front of the machine, position the drive belt over the top of the Blade Pulley while keeping it tight on the Clutch and Idler Pulley.
4. Insert the Drive Belt "V" into the Blade Pulley Groove the left side of the machine. Rotate the Blade Pulley Clockwise until the Drive Belt slides fully into the Pulley groove.
5. Perform a final check to ensure that the belt is installed properly into the Clutch, Idler and Blade Pulleys.
6. Reinstall the Belt Cover, Gas Tank Plate, and Cable Clamps that were removed in the previous section.

NOTICE

When positioning the Gas Tank Plate be careful not to stretch the Fuel and Vapor Lines. Ensure that the Fuel and Vapor Lines are not pinched under the Gas Tank Plate.

7. Secure the Fuel and Vapor Lines that were removed in the previous section into the Cable Guide.

Removing and Replacing the Swinging Blades

Note: Replace the Blade(s) when worn or damaged.

Tools and Supplies needed:

- Two 1-1/8" Wrenches
- Gloves

! WARNING

Wear gloves and use caution when pushing or pulling the wrench next to the blade. If the wrench slips off the bolt you may be seriously injured.

1. Disconnect the Tow Behind DR Field and Brush Mower from the Tow Vehicle.
2. Use Jack Stands or Ramps to lift the front of the Mower off the Ground. Chock the rear wheels to prevent them from moving.
3. Remove the Bolt and Lock Nut securing the Swinging Blade to the Blade Carrier using two 1-1/8" Wrenches and remove the Blade. (**Figure 37**).
4. Position the new or sharpened Swinging Blade under the Blade Carrier. Push the Bolt up From the Bottom and secure on top with the Locknut.
5. Using two 1-1/8" Wrenches, tighten the Locknut until it touches the Blade Carrier to allow for the Blade Swinging action.

Note: If the Blade does not swing freely after tightening, loosen the Locknut about 1/4 to 1/2 turn.

6. Repeat steps 3 through 5 for the other Swinging Blade.

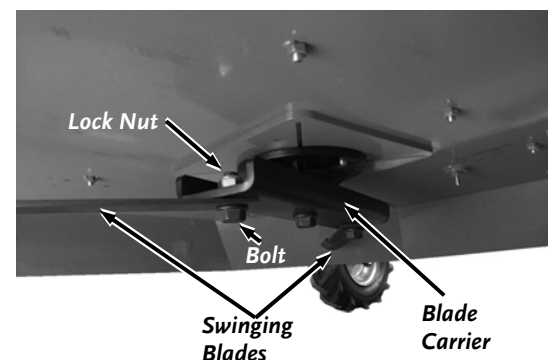

Figure 37

Replacing the Carbon Canister (Pro and Pro-XL Models)

Tools needed:

- Wire Cutters
- Pliers

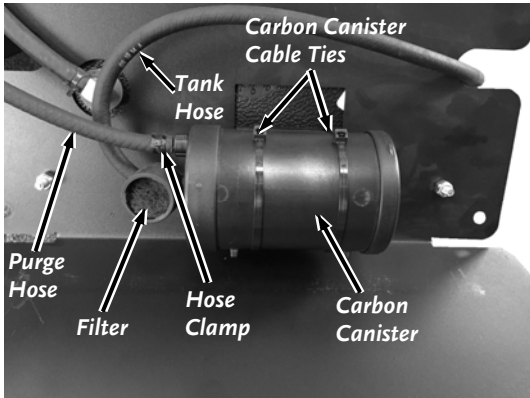

Figure 38

1. Remove the Gas tank Plate as described in section “Removing and Replacing the Drive Belt” in this Chapter.
2. Cut the two Cable Ties that are securing the Carbon canister to the Gas Tank Plate using Wire Cutters (**Figure 38**).
3. Remove the rubber Filter Elbow for better access to the Hoses.
4. Slide the Hose Clamps down from the Hose connections using Pliers and twist the Hoses from the Canister.
5. Install the Hoses onto the new Carbon Canister and position the Hose Clamps with Pliers.

Note: The Hoses *MUST* be installed onto the new Canister in the same location as they were on the old Canister. The Canister is labeled “Purge” (this hose is from the engine) and “Tank” (this hose is from the top of the fuel tank).

6. Slide new Cable Ties through the Canister Brackets and position the Canister onto the Brackets. Make sure the Filter is facing down (the filter can be rotated if needed).
7. Tighten the Cable Clamps around the Canister and cut the excess with Wire Cutters.

Battery Care

Proper care can extend the life of a Battery. Follow these recommendations to ensure your Battery's best performance and long life:

- Do not allow the Battery charge to get too low. If the machine is not used, charge the Battery every 4 – 6 weeks. Operate the Engine for at least 45 minutes to maintain proper Battery charge.
- Store an unused Battery in a dry area that does not freeze.
- Do not charge an already charged Battery. In theory, you cannot overcharge our Battery with a trickle Charger; however, when a Battery is fully charged and the Charger is still on, it generates heat that could be harmful to the Battery. A fully charged Battery will read 12V-13.2V with a Voltmeter.
- Do not continue to crank the Engine when the Battery charge is low.

Disposing of the Battery Responsibly

The Battery is a sealed lead-acid Battery. Recycle or dispose of it in an environmentally sound way.

- Do not dispose of a lead-acid Battery in a fire; the Battery may explode or leak.
- Do not dispose of a lead-acid Battery in your regular, household trash. Laws in most areas prohibit incinerating, disposing in a landfill, or mixing a sealed lead-acid Battery with household trash.

Charging the Battery

Operate the Mower Engine for at least 45 minutes to maintain proper Battery charge. If the Battery loses its charge, you'll need to use a trickle Charger (like the DR Battery Charger) to recharge it. The Charger should have an output of 12 volts at no more than 2 amps.

Note: *The charging system of a running engine is designed to maintain a battery's present charge. Starting a machine that has a significantly discharged or dead Battery using the Recoil Starter or Jumper Cables will not recharge the Battery.*

To connect a Battery Charger to your TOW BEHIND DR FIELD and BRUSH MOWER, follow the steps listed below.

1. Detach the two Battery wires going to the Battery on your Mower.
2. Attach the black (-) Battery Charger wire to the Battery negative (-) terminal, and attach the red (+) Battery Charger wire to the Battery positive (+) terminal.
3. Plug the Battery Charger into an outlet.
4. Charge until Battery Charger indicates that it is charged or Battery measures to 12-14V
 - At 1 amp, you may have to charge the Battery for as long as 24 hours.
 - At 2 amps, you may have to charge the Battery for as long as 12 hours.
5. Once Charged, disconnect Charger from outlet
6. Disconnect Battery from the Charger.
7. Reconnect the Battery Wires.

Recycling a Used Battery

NOTICE

Please dispose of used batteries responsibly, according to your local hazardous materials regulations. Never throw away used batteries in your household trash.

Please dispose of your used Batteries responsibly by recycling them. Call your local Solid Waste Management District or your local waste handler to locate the collection site nearest you. Some collection sites recycle Batteries year-round; others collect them periodically.

Visit these sites for more information:

- Web site of Earth 911 [www.earth911.com]
- International Metals Reclamation Company [www.inmetco.com]
- Battery Council International [www.batterycouncil.org]
- Environmental Protection Agency [www.epa.gov]

Chapter 5: Troubleshooting

Most problems are easy to fix. Consult the Troubleshooting Table below for common problems and their solutions. If you continue to experience problems, contact us at www.DRpower.com or call toll-free 1-800-DR-OWNER (376-9637) for support.

WARNING

When performing any adjustment or maintenance, you must first shut off the engine, wait five (5) minutes to allow parts to cool and disconnect the spark plug wire(s), keeping it away from the spark plug(s).

Troubleshooting Table

SYMPTOM	POSSIBLE CAUSE
<p><i>The Engine will not start.</i></p> <p><i>(Please refer to the Engine Owner's Manual for Engine-specific procedures.)</i></p>	<ul style="list-style-type: none"> ⇒ Check all the items under the section called "Starting" in Chapter 3. ⇒ Check that the Blade Switch Safety Cover is DOWN in the Disengaged position. ⇒ Make sure the Spark Plug wire(s) is attached. ⇒ If the Engine is cold, make sure the Throttle is in the CHOKE position. See "Starting" in Chapter 3. ⇒ The gas must be fresh and clean. If the gas is old, change it. Use a fuel stabilizer if you keep gas longer than one month. ⇒ The Spark Plug(s) may be dirty or cracked, change it. ⇒ If the Spark Plug(s) is oily, leave it out, hold a rag over the Plug hole(s) and crank the Engine over a couple of times using the Electric Starter to blow out any oil in the Cylinder(s), then wipe off the Plug(s) and reinsert it. ⇒ The Air Filter may be dirty, change it following the procedure in the Engine Owner's Manual. ⇒ There are two Fuses in the Wiring Harness. Check the Fuses and replace if needed. ⇒ Check the wire connections—especially the ground connection, the large green wire coming from the Battery, where it connects to the Engine. ⇒ The Battery may not be charged. Check the voltage yourself or at a service station. If it is low, charge it with a 12-volt, 1 to 2-amp trickle charger. If you do not use your machine for at least 45 minutes at a time, the Battery may need to be periodically charged. See the "Battery Care" section in Chapter 4. ⇒ If the Battery is charged and the DR TOW-BEHIND FIELD & BRUSH MOWER still will not start, visit our website at www.DRpower.com.
<p><i>The Engine lacks power or is not running smoothly.</i></p> <p><i>(Please refer to the Engine Owner's Manual for Engine-specific procedures.)</i></p>	<ul style="list-style-type: none"> ⇒ The Throttle Lever may be in the wrong position; Make sure the Throttle Lever is in the RUN position. ⇒ The Air Filter may be dirty, change it following the procedure in the Engine Owner's Manual. ⇒ The Spark Plug(s) may be dirty or cracked, change it. ⇒ If the Spark Plug(s) is oily, leave it out, hold a rag over the Plug hole(s) and crank the Engine over a couple of times using the Electric Starter to blow out any oil in the Cylinder(s), then wipe off the Plug(s) and reinsert it. ⇒ The gas must be fresh and clean. If the gas is old, change it. Use a fuel stabilizer if you keep gas longer than one month. ⇒ The Engine may not have the right amount of clean oil. If it is dirty, change it following the procedure in Chapter 4. ⇒ If the Engine still lacks power, visit our website at www.DRPower.com.

! WARNING

When performing any adjustment or maintenance, you must first shut off the engine, wait five (5) minutes to allow parts to cool and disconnect the spark plug wire(s), keeping it away from the spark plug(s).

Troubleshooting Table (Continued)

SYMPTOM	POSSIBLE CAUSE
<i>Engine smokes.</i>	<ul style="list-style-type: none">⇒ Check the oil level and adjust as needed.⇒ You may be operating the machine on too great an incline. See “Slopes and Uneven Terrain” in Chapter 3⇒ Check the Air Filter(s) and clean or replace if needed.⇒ You may be using the wrong oil—too light for the temperature. Refer to your Engine Owner’s Manual for detailed information.⇒ Clean the Cooling Fins and the Carburetor housing if they are dirty.⇒ If the Engine still smokes, visit our website at www.DRPower.com for assistance
<i>The Belt frays or rolls over the Pulley.</i>	<ul style="list-style-type: none">⇒ There may be a nick in a Pulley groove. Check the Belt for wear and hard spots. File off any nicks on the Pulley.⇒ The Belt may be stretched; replace it. See Chapter 4.
<i>Blades vibrate when engaged.</i>	<ul style="list-style-type: none">⇒ The Blade Carrier Mounting Bolt may not be tight enough. Tighten the Bolt as tight as possible by hand with at least a 1ft long 1-1/8” Wrench.⇒ A Swinging Blade may be too loose on the Blade Carrier. Re-tighten the Swinging Blade mounting hardware. See Chapter 4. Be sure to turn OFF the Engine and remove the Spark Plug wire(s) before performing this operation.⇒ Replace a Swinging Blade if it is chipped, bent, or broken.⇒ The Spindle Bearings may be damaged or the Spindle Shaft is bent.⇒ If the Blades still vibrate, visit our website at www.DRpower.com for assistance.
<i>The Blades are not cutting or are loose.</i>	<ul style="list-style-type: none">⇒ The Blade Carrier Mounting Bolt may not be tight enough. Tighten the Bolt as tight as possible by hand with at least a 1ft long 1-1/8” Wrench.⇒ A Swinging Blade may be too loose on the Blade Carrier. Re-tighten the Swinging Blade mounting hardware. See Chapter 4. Be sure to turn OFF the Engine and remove the Spark Plug wire(s) before performing this operation.⇒ Sharpen the Swinging Blades; they may be dull or nicked.
<i>The Blades will not Engage and/or Disengage.</i>	<ul style="list-style-type: none">⇒ Faulty Blade Control Switch. Remove and replace the Switch on the Remote Control.⇒ Faulty Electric Clutch. Visit our website at www.DRpower.com for assistance.⇒ Low or weak battery may cause electric clutch to not engage. Check battery for sufficient voltage.
<i>Uneven cut.</i>	<ul style="list-style-type: none">⇒ Left and Right Deck Height Adjusters are not at the same setting.
<i>Excessive Engine stalling.</i>	<ul style="list-style-type: none">⇒ The brush or grass is too heavy at the current cutting height or at the current Tow Vehicle speed. Raise the cutting height and drive slower when cutting.

Chapter 6: Parts Lists and Schematic Diagrams

Parts List – Frame and Tow Bar

NOTE: Part numbers listed are available through DR Power Equipment.

<u>Ref#</u>	<u>Part#</u>	<u>Description</u>	<u>Ref#</u>	<u>Part#</u>	<u>Description</u>
1	37138	Support, Wheels, Brush, Right, with Labels	16	36315	Bracket, Chain Guard
2	36581	Label, Height Adjust, Right	17	34324	Bolt, HCS, 3/4-10 X 7, ZP
3	37125	Label, Crank Direction	18	36573	Bolt, Hex, Flange, 1/2-13 X 4.5", GR5, ZP
4	37139	Support, Wheels, Brush, Left, with Labels	19	34511	Bolt, Hex, Flange, 1/2-13 X 3", GR5, ZP
5	36582	Label, Height Adjust, Left	20	35281	Bolt, Hex, Flange, Tri Lobe, 3/8-16 X 3/4", GR5 ZP
6	37120	Guard, Push Bar	21	11170	Screw, 10-32 X 1/2", Type F, Hex, ZP
7	36273	Push Bar	22	23499	Washer, SAE Flat, 1/2", ZP
8	35498	Caster, Front, Brush	23	33338	Nut, Nylon Lock, Flanged, 3/4-10
9	35482	Wheel, 13 X 5-6, Lug Tread	24	33335	Nut, Nylon Lock, Flanged, 1/2-13
10	35481	Wheel, 11 X 4-5, Flat Free, Smooth Tread	25	18655	Pin, Cotter, 3/16" x 2"
11	35495	Bracket, Offset	26	18737	Pin, Clevis, 1/2" OD X 4.5" LG
12	35496	Tow Bar	27	25549	Pin, Clevis, 1/2" X 2 1/2"
13	35497	Extension, Tow Bar	28	16003	Pin, Hair, 1/2" To 9/16", .12" Wire
14	36317	Welded Chain, 1/4", Grade 30 Proof Coil, 8 Links	29	36311	Cable Clamp, .75" Bundle, #10 Screw
15	36316	Rod, Retention, Chain Guard			

Schematic – Frame and Tow Bar

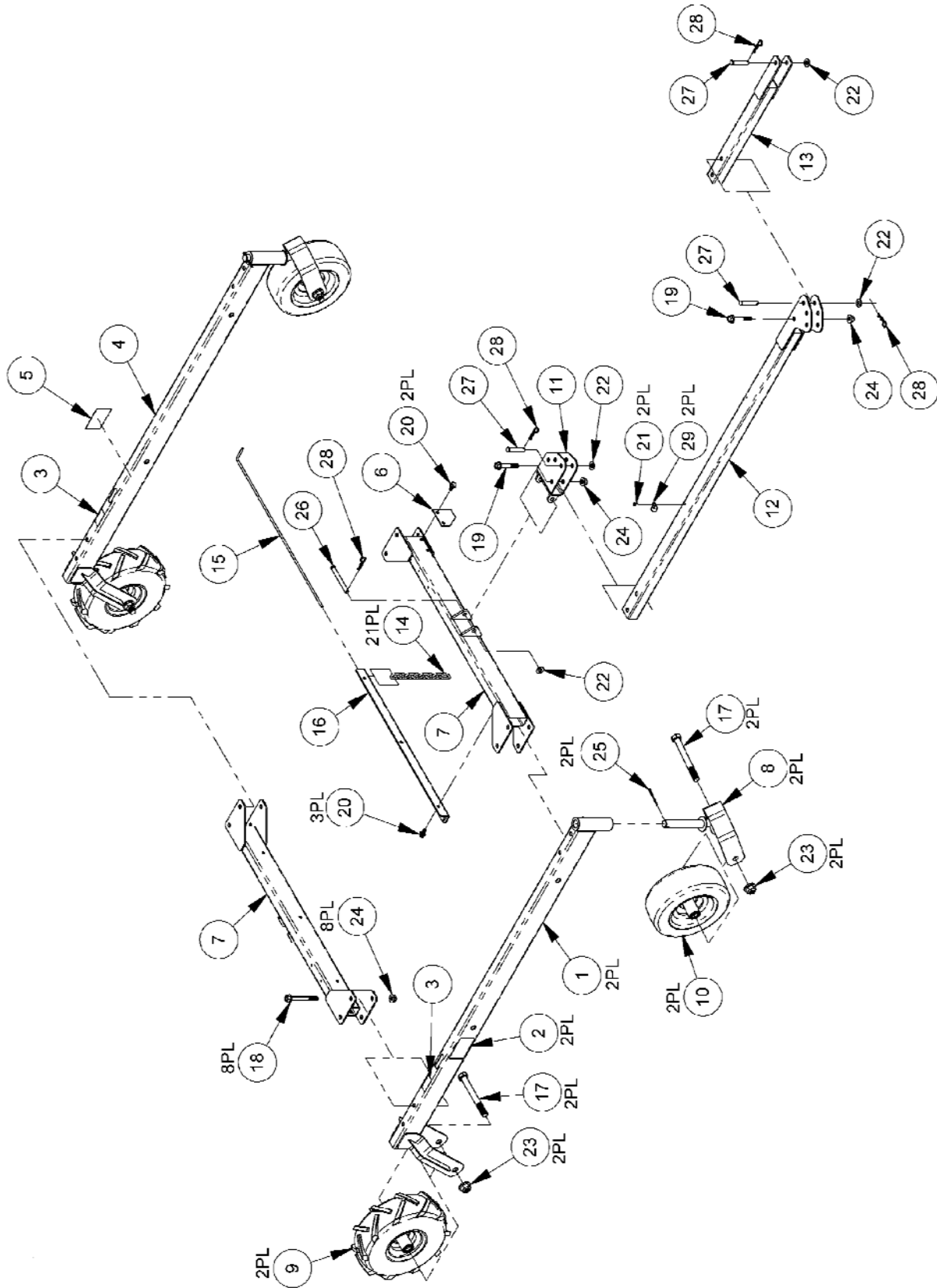

Parts List – Deck and Deck Lift

NOTE: Part numbers listed are available through DR Power Equipment.

Ref#	Part#	Description	Ref#	Part#	Description
1	35494	Brace, Sway	26	36563	Bolt, Hex, Flange, 1/2-13 X 1.25", GR5, ZP
2	36289	Bushing, Sway Brace	27	36572	Bolt, Hex, Flange, 1/2-13 X 3.5", GR5, ZP
3	36312	Acme Thread, Height Adjust	28	34512	Bolt, Hex, Flange, 3/8-16 X .75", GR5, ZP
4	36574	Shim, Nylon, .76" ID X .1.31" OD X .06" Thk	29	15712	Bolt, HCS, 3/8-16 X 2-1/4", GR5, ZP
5	36576	4-Lobe Knob, 5/16-18 X 1/2" Stud, ZP	30	11465	Bolt, HCS FT, 3/8-16 X 3", GR5, ZP
6	35499	Block, Height Adjust	31	11148	Bolt, HCS, 1/4-20 X 1.75", GR5, ZP
7	36254	Crank, Hand	32	11170	Screw, 10-32 X 1/2", Type F, Hex, ZP
8	37121	Crank, Hand, Break-Away	33	35093	Washer, Flat, 1", ZP
9	37141	Deck, Brush, 44", w/Labels	34	11239	Washer, Flat, 3/8", USS
10	13649	Label, Danger, Blade	35	22253	Washer, Lock, 3/8"
11	37122	Label, Warnings	36	33338	Nut, Nylon Lock, Flanged, 3/4-10
12	37134	Plate, Gas Tank, Brush, w/Labels	37	33335	Nut, Nylon Lock, Flanged, 1/2-13
13	36580	Label, Branding	38	36575	Nut, Acme, 1/2-10, GR2, ZP
14	36259	Spindle, Assembly, Brush	39	33333	Nut, Nylon Lock, Flanged, 3/8-16
15	32237	Key, ANSI #806 Woodruff, 1/4" X 3/4"	40	18755	Nut, Nylon Lock, 5/16-18, LP
16	36546	Carrier, Blade	41	11073	Nut, Nylon Lock, 1/4-20, ZP
17	37110	Blade, Swinging, Air Tip/ w/Hardware	42	36577	Detent Pin, Grip Ring, 1/4" X 1-1/4", ZP
18	36307	Washer, Blade	43	36311	Cable Clamp, .75" Bundle, #10 Screw
19	36263	Idler Arm	44	37133	Rail, Support, w/Labels
20	36258	Bushing, .380" X .664" X .9"	45	35491	Mount, Motor, Brush
21	36256	Pulley, 11" OD, 1" Bore, 1/4" Key, B	46	35492	Channel, Support, Left
22	15127	Pulley, Flat Idler, 4"	47	35493	Channel, Support, Right
23	36555	Spring, 1" OD, 8" L, .105" Wire	48	36255	Cover, Belt, Brush
24	36288	Belt, B49	49	37119	Mount, Molex
25	36564	Bolt, Hex, Flange, 3/4-10 X 1.75", GR5, ZP			

Schematic – Deck and Deck Lift

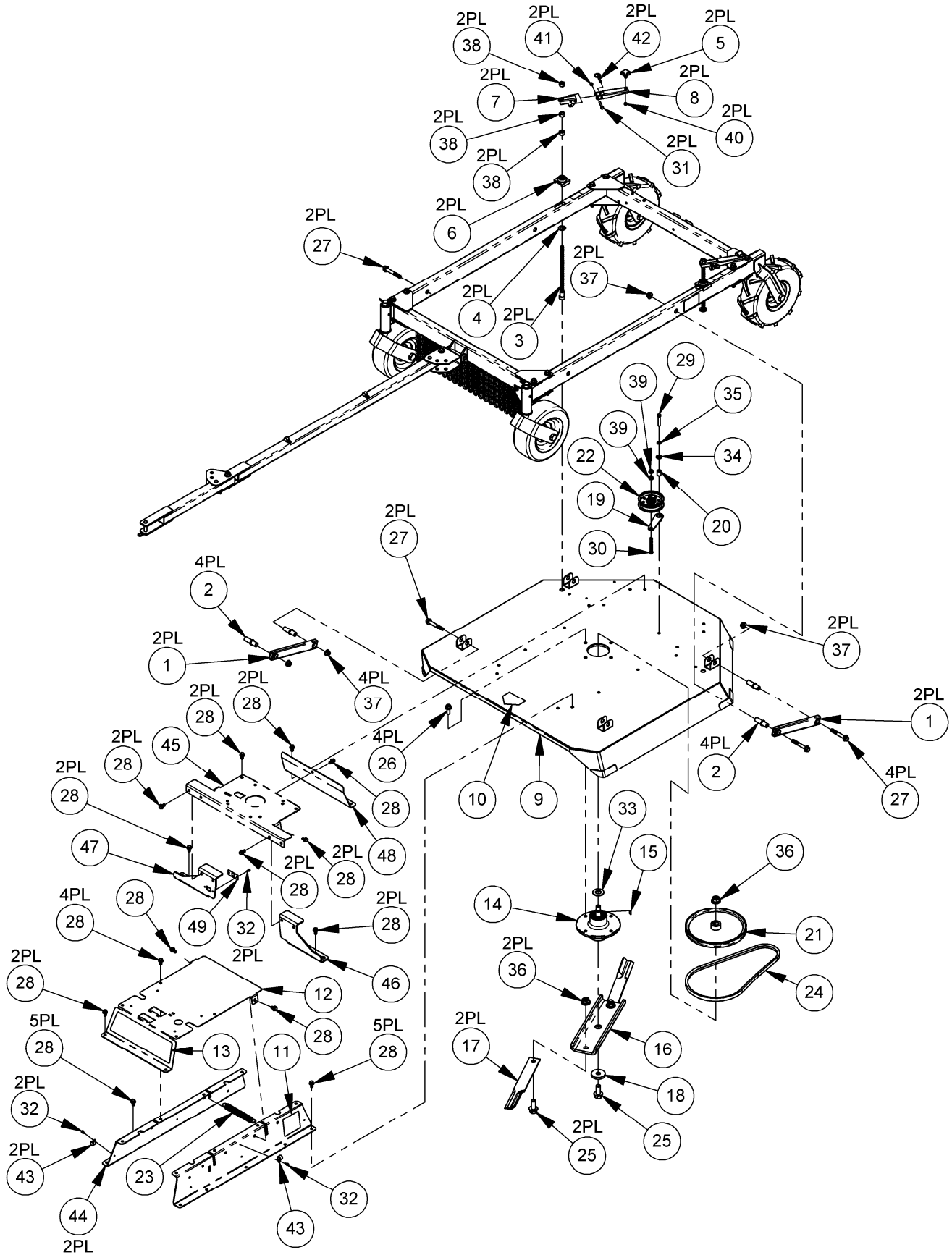

Parts List – Drive, Gas and Control

NOTE: Part numbers listed are available through DR Power Equipment.

Ref#	Part#	Description	Ref#	Part#	Description
1	37134	Plate, Gas Tank, Brush, with Labels	33	35281	Bolt, Hex, Flange, Tri Lobe, 3/8-16 X 3/4", GR5 ZP
2	33386	Clutch, Electric, 75 Ft-Lbs, w/Key (16.5hp Only)	34	34512	Bolt, Hex, Flange, 3/8-16 X .75", GR5, ZP
	35016	Clutch, Electric, 95 Ft-Lbs, w/Key (20hp Only)	35	34325	Bolt, Hex, Flange, 1/4-20 X 1"
3	22142	Spacer, 1.00" ID X 1.75" OD X 1.25"	36	11170	Screw, 10-32 X 1/2", Type F, Hex, ZP
4	37146	Engine, B&S, 16.5HP, Pro Series, ES, w/Labels	37	37112	Screw, Plastic Thread Forming, Pan Head, # 2 Philips, #8-18 X 3/4", Stl, ZP
	34448	Engine, B&S, 20HP V-Twin, w/Labels and Exhaust	38	15049	Screw, 8-32 x 1/2"
5	34130	Gasket, Exhaust, Briggs, 20hp Vtwin (20hp Only)	39	19130	Washer, Flat, .469" X 1.62" X .25"
6	35056	Bolt, Muffler, B&S, 20hp (20hp Only)	40	22252	Washer, Lock, 7/16", Split ZP
7	17912	Screw, 1/4-20 X .500", Tri-Lobe	41	31283	Nut, Lock, 1/4-20, Serrated Flange
8	13758	Label, Check Oil, 2.75" x .63"	42	11073	Nut, Nylon Lock, 1/4-20, ZP
9	13683	Label, Caution, Hot Surface	43	36552	Wire Harness, Machine
10	34444	Guard, Exhaust, B&S V-Twin (20hp Only)	44	36550	Wire Harness, Tether
11	36361	U-bolt, 1-1/8" ID, 1/4-20 x 1"	45	36551	Wire Harness, Hand Control
12	13447	Battery, 12V, 9ah	46	36303	Hand Control, Back
13	24230	Strap, Battery, 9ah	47	37137	Hand Control, Front, w/Labels
14	36304	Switch, Toggle, DPDT	48	36584	Label, Blade Engage
15	37135	Control Panel, w/Labels	49	36305	Safety Cover, Toggle Switch
16	36585	Label, Throttle Control	Not Shown		
17	28336	Fuel Tank Assy, 2.5 Gal, Certified	34333		Deflector, Briggs (16.5hp Only)
18	36549	Cable, Throttle, 30" L	34331		Muffler Guard, B&S (16.5hp Only)
19	35280	Muffler, B&S, 20HP, Horizontal (20hp Only)	34334		Static Cover, Briggs (16.5hp Only)
20	26575	Carbon Canister, 300cc, 3/16" Ports	34332		Screw, Muffler guard (16.5hp Only)
21	36569	Hose, Vapor, 3/16" ID, 32" Long, w/Clamps (20hp Only)	34335		Screw, B&S, static cover (16.5hp Only)
22	26581	Clamp, Vapor Line	15045		Bolt, HCS, 5/16-18x1 3/4, Gr5,zp, ground (16.5hp Only)
23	36568	Hose, Vapor, 3/16" ID, 24" Long, w/Clamps	11069		Nut, Finish, 5/16-18, zp, ground (16.5hp Only)
24	22223	Switch, Snap-On, E/S	11250		Washer, Star Lock, 5/16, ground (16.5hp Only)
25	36571	Hose Fuel Ca Cert, 12" Long, w/Clamps	34275		Wire, Battery, Ground
26	10066	Clamp Fuel Line	37140		Label, QR Code
27	37113	Hose, Fuel, Ca Cert, 2" Long, w/Clamps (20hp Only)	35507		Label, EPA/CARB 2015
28	15720	Key, Ignition Switch	26570		Hose, Vapor, 3/16" ID, 39" Long, w/ Clamps (16.5hp Only)
29	36286	Valve, Fuel Shutoff	37114		Hose Fuel CA Cert, 20" Long, w/ Clamps (16.5hp Only)
30	12797	Cable Tie, 17", # 50	31283		Nut, Lock, 1/4-20, Serrated Flange (located on starter motor)
31	22237	Strap, Fuel Tank, 2.5 Gal	17912		Bolt, Tri, 1/4-20x1/2, (ground, 20hp Only)
32	22214	Bolt, 7/16-20 X 2-1/4", GR8, ZP			

Schematic – Drive, Gas and Control

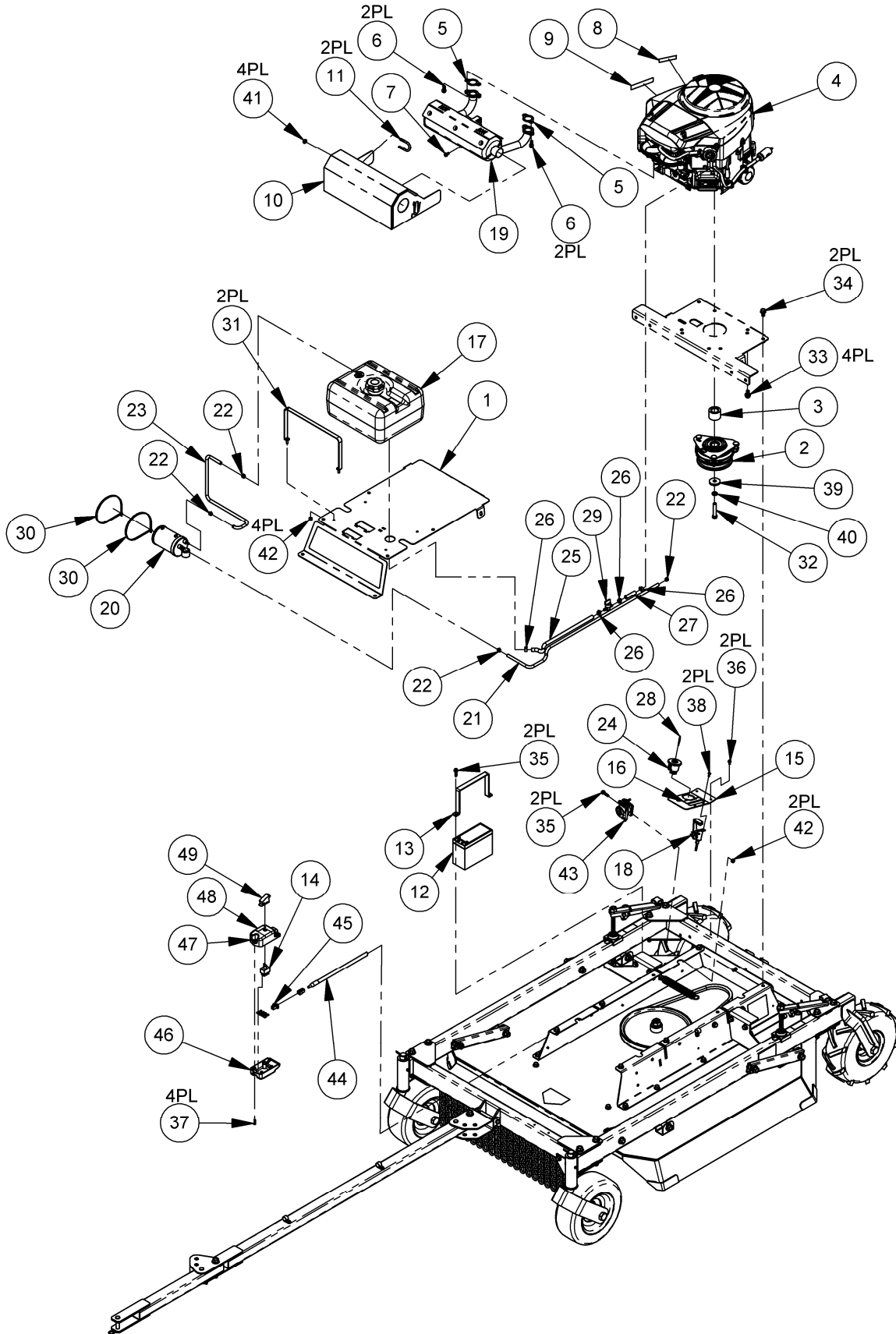

Daily Checklist for the TOW-BEHIND DR FIELD and BRUSH MOWER

To help maintain your **TOW-BEHIND DR FIELD and BRUSH MOWER** for optimum performance, we recommend you follow this checklist each time you use your machine.

WARNING

When performing any adjustment or maintenance, you must first shut off the engine, wait five (5) minutes to allow parts to cool and disconnect the spark plug wire(s), keeping it away from the spark plug(s).

- Check the engine oil and Gas Tank level.
- Check that Engine is clean of debris.
- Check the general condition of the Mower, e.g.; nuts, bolts, welds, etc.
- Check Tire Pressure and wear.
- Check the Frame for wear and damage.
- Check the Blades and Spindle for tightness, nicks, cracks, wear or debris that has wrapped around.
- Check that the Remote Control is secure.

End of Season and Storage

WARNING

When performing any adjustment or maintenance, you must first shut off the engine, wait five (5) minutes to allow parts to cool and disconnect the spark plug wire(s), keeping it away from the spark plug(s).

Note: Please refer to the Engine Owner's Manual for Engine-specific procedures.

- Change the Engine oil and Oil Filter and replace the Fuel Filter.
- Remove the Spark Plug(s) and pour about 1 ounce of motor oil into the Cylinder hole. Replace the Plug(s) and crank the Engine over a couple of times using the Electric Starter. This will coat the pistons and seat the valves to prevent moisture buildup.
- Clean or replace the Air Filter(s).
- Clean dirt and debris from the Cylinder Head Cooling Fins, Blower Housing, Debris Screen, and Muffler area of the Engine.
- If your TOW-BEHIND DR FIELD and BRUSH MOWER will be idle for more than 30 days, we recommend using a gas stabilizer. This will prevent sediment from gumming up the Carburetor. If there is dirt or moisture in the gas or tank, remove it by draining the tank. Completely fill the tank with fresh, unleaded gas and add the appropriate amount of stabilizer or gasoline additive. Run the Engine for a short time to allow the additive to circulate.
- Remove any wrapped weeds from the Blades Carrier Housing. Clean grass and debris from the top and underneath the mower Deck with a stiff brush.
- Check the Blades for nicks and wear. Remove the Blades and sharpen them, or have them professionally sharpened if needed.
- Touch-up all rusted or chipped paint surfaces. Sand them lightly before painting.
- Be sure all nuts, bolts, and screws are securely fastened.
- Inspect moving parts and the Blades' Drive Belt for damage and wear; replace if necessary.
- Store the Battery in a dry area that will not freeze. If you will not use the machine over a long period, charge the Battery every four to six weeks.
- If possible, store your TOW-BEHIND DR FIELD and BRUSH MOWER inside, but not near an open flame or spark such as found in a water heater.
- After the TOW-BEHIND DR FIELD and BRUSH MOWER has cooled, cover the machine with a suitable protective cover that does not retain moisture. Do not use plastic, as this material cannot breathe; it also allows condensation to form, which will cause your machine to rust.



75 MEIGS ROAD, P.O. BOX 25, VERGENNES, VERMONT 05491