

DR[®] 6.25 TOW-BEHIND TRIMMER/MOWER

SAFETY & OPERATING INSTRUCTIONS



Serial No. _____

Order No. _____

Original Language

DR Power Equipment
Toll-free phone: 1-800-DR-OWNER (376-9637)
Fax: 1-802-877-1213
Website: www.DRpower.com

WARNING

Read and understand this manual and all instructions before operating the DR 6.25 TOW-BEHIND TRIMMER/MOWER.

Table of Contents

Chapter 1: General Safety Rules.....	3
Chapter 2: Setting Up the DR 6.25 TOW-BEHIND TRIMMER/MOWER	6
Chapter 3: Operating the DR 6.25 TOW-BEHIND TRIMMER/MOWER	12
Chapter 4: Maintaining the DR 6.25 TOW-BEHIND TRIMMER/MOWER.....	16
Chapter 5: Troubleshooting	21
Chapter 6: Parts Lists and Schematic Diagrams.....	24

Conventions used in this manual

DANGER

This indicates a hazardous situation, which, if not followed, will result in death or serious injury.

WARNING

This indicates a hazardous situation, which, if not avoided, could result in death or serious injury.

CAUTION

This indicates a hazardous situation, which, if not avoided, could result in minor or moderate injury.

NOTICE

This information is important in the proper use of your machine. Failure to follow this instruction could result in damage to your machine or property.

Serial Number and Order Number

A Serial Number is used to identify your machine and is located on the Serial Number Label on your machine. An Order Number is used to check and maintain your order history and is located on the upper left portion of your packing slip. For your convenience and ready reference, enter the Serial Number and Order Number in the space provided on the front cover of this manual.

Additional Information and Potential Changes

DR Power Equipment reserves the right to discontinue, change, and improve its products at any time without notice or obligation to the purchaser. The descriptions and specifications contained in this manual were in effect at printing. Equipment described within this manual may be optional. Some illustrations may not be applicable to your machine.

Chapter 1: General Safety Rules

WARNING

Read this Safety & Operating Instructions manual before you use the DR 6.25 TOW-BEHIND TRIMMER/MOWER. Become familiar with the operation and service recommendations to ensure the best performance from your machine. If you have any questions or need assistance, please contact us at www.DRpower.com or call toll-free 1-800-DR-OWNER (376-9637) and one of our Technical Support Representatives will be happy to help you.

Labels

Your DR 6.25 TOW-BEHIND TRIMMER/MOWER carries prominent labels as reminders for its proper and safe use. Shown below are copies of the Safety and Information labels that appear on the equipment. Take a moment to study them and make a note of their location on your DR 6.25 TOW-BEHIND TRIMMER/MOWER as you set up and before you operate the unit. Replace damaged or missing safety and information labels immediately.



#14823



#34162



#34148



#13758



#13649

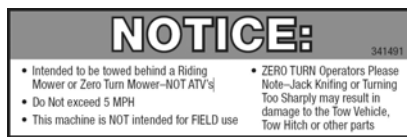

#34149



#34167

Protecting yourself and those around you

WARNING

This is a high-powered machine, with moving parts operating with high energy at high speeds. You must protect yourself and others from possible injury. Not taking proper precautions can create a number of hazards for you, as well as anyone else in the nearby area. Always take the following precautions when using this machine:

- Always wear protective goggles or safety glasses with side shields while trimming to protect your eyes from possible thrown debris.
- Avoid wearing loose clothing or jewelry, which can catch on the machine's moving parts.
- We recommend wearing gloves while using this machine. Be sure your gloves fit properly and do not have loose cuffs or drawstrings.
- Wear shoes with non-slip treads when using your DR 6.25 TOW-BEHIND TRIMMER/MOWER. If you have safety shoes, we recommend wearing them. Do not use the machine while barefoot or wearing sandals with exposed toes or heels.
- Wear long pants while operating the DR 6.25 TOW-BEHIND TRIMMER/MOWER.
- Use ear protectors or ear plugs rated for at least 20 dba to protect your hearing.
- Keep bystanders at least 100 feet away from your work area at all times. The tips of the cutting cords on the DR 6.25 TOW-BEHIND TRIMMER/MOWER can throw sticks, small stones, gravel, and bits of debris over long distances at great velocity. Do not travel over loose materials such as gravel or mulch with the trimmer head spinning. Doing so could cause personal injury or property damage from thrown objects. Shut off the Tow Vehicle, set the parking brake and remove the key and then shut down the Trimmer Engine to stop the spinning cords when another person or pet approaches.
- Never tamper with safety devices. Check their proper operation regularly.
- Never operate the machine when under the influence of alcohol, drugs, or medication.

Safety for Children and Pets

WARNING

Tragic accidents can occur if the operator is not alert to the presence of children and pets. Children are often attracted to the machine and the trimming activity. *Never* assume that children will remain where you last saw them. Always follow these precautions:

- Keep children and pets out of the working area and under the watchful care of a responsible adult.
 - Be alert and turn the machine off if children or pets enter the work area.
 - Never allow children to operate the DR 6.25 TOW-BEHIND TRIMMER/MOWER.
 - Use extra care when approaching blind corners, shrubs, trees, or other objects that may obscure your vision.
-

Safety with Gasoline - Powered Machines

WARNING

Gasoline is a highly flammable liquid. Gasoline also gives off flammable vapor that can be easily ignited and cause a fire or explosion. Never overlook the hazards of gasoline. Always follow these precautions:

- Never run the engine in an enclosed area or without proper ventilation as the exhaust from the engine contains carbon monoxide, which is an odorless, tasteless, and deadly poisonous gas.
 - Store all fuel and oil in containers specifically designed and approved for this purpose and keep away from heat and open flame, and out of the reach of children.
 - Replace rubber fuel lines and grommets when worn or damaged and after 5 years of use.
 - Fill the gasoline tank outdoors with the engine off and allow the engine to cool completely. Don't handle gasoline if you or anyone nearby is smoking, or if you're near anything that could cause it to ignite or explode. Reinstall the fuel tank Cap and fuel container cap securely.
 - If you spill gasoline, do not attempt to start the engine. Move the machine away from the area of the spill and avoid creating any source of ignition until the gas vapors have dissipated. Wipe up any spilled fuel to prevent a fire hazard and properly dispose of the waste.
 - Allow the engine to cool completely before storing in any enclosure. Never store a machine that has gas in the tank, or a fuel container, near an open flame or spark such as a water heater, space heater, clothes dryer or furnace.
 - Never make adjustments or repairs with the engine running. Shut down the engine, wait 5 minutes, disconnect the spark plug wire, keeping it away from the spark plug to prevent accidental starting before making adjustments or repairs.
 - Never tamper with the engine's governor setting. The governor controls the maximum safe operation speed and protects the engine. Over-speeding the engine is dangerous and will cause damage to the engine and to the other moving parts of the machine. If required, see your authorized dealer for engine governor adjustments.
 - Keep combustible substances away from the engine when it is hot.
 - Never cover the machine while the muffler is still hot.
 - Do not operate the engine with the air cleaner or cover over the carburetor air-intake removed, except for adjustment. Removal of such parts could create a fire hazard. Do not use flammable solutions to clean the air filter.
 - The muffler and engine become very hot with use and can cause a severe burn; do not touch. Allow the engine to cool before refueling, doing maintenance, or making adjustments.
 - Do not mow in the rain. Water on the spark plug may cause the engine to stall.
 - Keep combustible substances away from the engine when it is hot.
 - Never cover the machine while the muffler is still hot.
-

Operating the Trimmer/Mower Safely

WARNING

This is a high-powered machine, with moving parts operating with high energy at high speeds. You must operate the machine safely. Unsafe operation can create a number of hazards for you, as well as anyone else in the nearby area. Keep in mind that the operator or user is responsible for accidents or hazards occurring to other people, their property, and themselves. Always take the following precautions when using this machine:

- Be cautious when trimming in reverse and do not hit any obstacles. The machine is designed to spring out of the way when hitting obstacles in the forward direction, not the reverse direction. If you hit obstacles with the Trimmer in the reverse direction the trimmer could be damaged and is not covered by the Warranty.
- Know how to stop the Trimmer quickly by shutting off the engine.
- Never allow people who are unfamiliar with these instructions to use the DR 6.25 TOW-BEHIND TRIMMER/MOWER. Allow only responsible individuals who are familiar with these rules of safe operation to use your machine.
- Do not exceed 1-3 mph when trimming to allow proper cutting and discharge of material.
- Do not exceed 5 mph when transporting to prevent damage to the machine.
- Operating your Trimmer/Mower with the head misaligned with the ground can result in poor cut quality, pivoting problems, scalping during cutting, wear on your equipment, and damage to the cutting cord
- Never place your hands, feet, or any part of your body on or under the mower deck in the path of the spinning cords, belt, pulleys, or near the discharge opening while the machine is running. Keep area of discharge clear of people, animals, buildings, glass, or anything else that will obstruct clear discharge, cause injury, or damage.
- Your DR 6.25 TOW-BEHIND TRIMMER/MOWER is a powerful tool, not a plaything. Exercise extreme caution at all times. The design of your machine is for trimming and mowing grass, weeds, and other growth as specified in this manual. Do not use it for any other purpose.
- Whenever you leave the operating position to make adjustments, change cords or if you have to remove grass or debris from the underside of the deck, always shut off the Tow Vehicle, set the parking brake and remove the Key. Shut off the Trimmer Engine and after all moving parts to come to a complete stop, then wait five minutes before performing any maintenance procedure or inspection on the Trimmer.
- Be mindful of roll over hazards, changes in terrain, slopes, or wet conditions. Use care when backing up.
- Stop the cutting cords when crossing gravel drives, walks, or roads.
- Never, under any conditions, remove, bend, cut, fit, weld, or otherwise alter standard parts on the DR 6.25 TOW-BEHIND TRIMMER/MOWER. This includes all shields and guards. Modifications to your machine could cause personal injuries and property damage and will void your warranty.
- If the cutting cords strike a foreign object or if your machine should start making an unusual noise or vibration, shut off the Tow Vehicle, set the parking brake and remove the Key. Shut off the Trimmer Engine and after all moving parts to come to a complete stop, wait five minutes before inspection. Vibration is generally a warning of trouble. Clean and repair and/or replace damaged parts.
- While using the DR 6.25 TOW-BEHIND TRIMMER/MOWER, do not hurry or take things for granted. When in doubt about the equipment or your surroundings, stop the machine and take the time to look things over. Make sure that you have 100% control of the Trimmer at all times.
- Watch for traffic when mowing near roadways.
- Use the machine only in daylight.
- Be cautious when using your DR 6.25 TOW-BEHIND TRIMMER/MOWER around fencing, wires, ropes, and hoses. It is possible that these and other debris can become wound around the Trimmer Head of the machine, potentially damaging the bearings or injuring you.
- Do not operate the DR 6.25 TOW-BEHIND TRIMMER/MOWER on slopes greater than is recommended in your Tow Vehicle's user manual.
- Keep all nuts and bolts tight and keep the equipment in good operating condition.

A Note to All Users

No list of warnings and cautions can be all-inclusive. If situations occur that are not covered by this manual, the operator must apply common sense and operate this DR 6.25 TOW-BEHIND TRIMMER/MOWER in a safe manner. Contact us at www.DRpower.com or call 1-800-DR-OWNER (376-9637) for assistance.

Chapter 2: Setting Up the DR 6.25 TOW-BEHIND TRIMMER/MOWER

It may be helpful to familiarize yourself with the controls and features of your DR 6.25 TOW-BEHIND TRIMMER/MOWER as shown in **Figure 1** before beginning these procedures. If you have any questions at all, please feel free to contact us at www.DRpower.com.

DR 6.25 TOW-BEHIND TRIMMER/MOWER Controls and Features

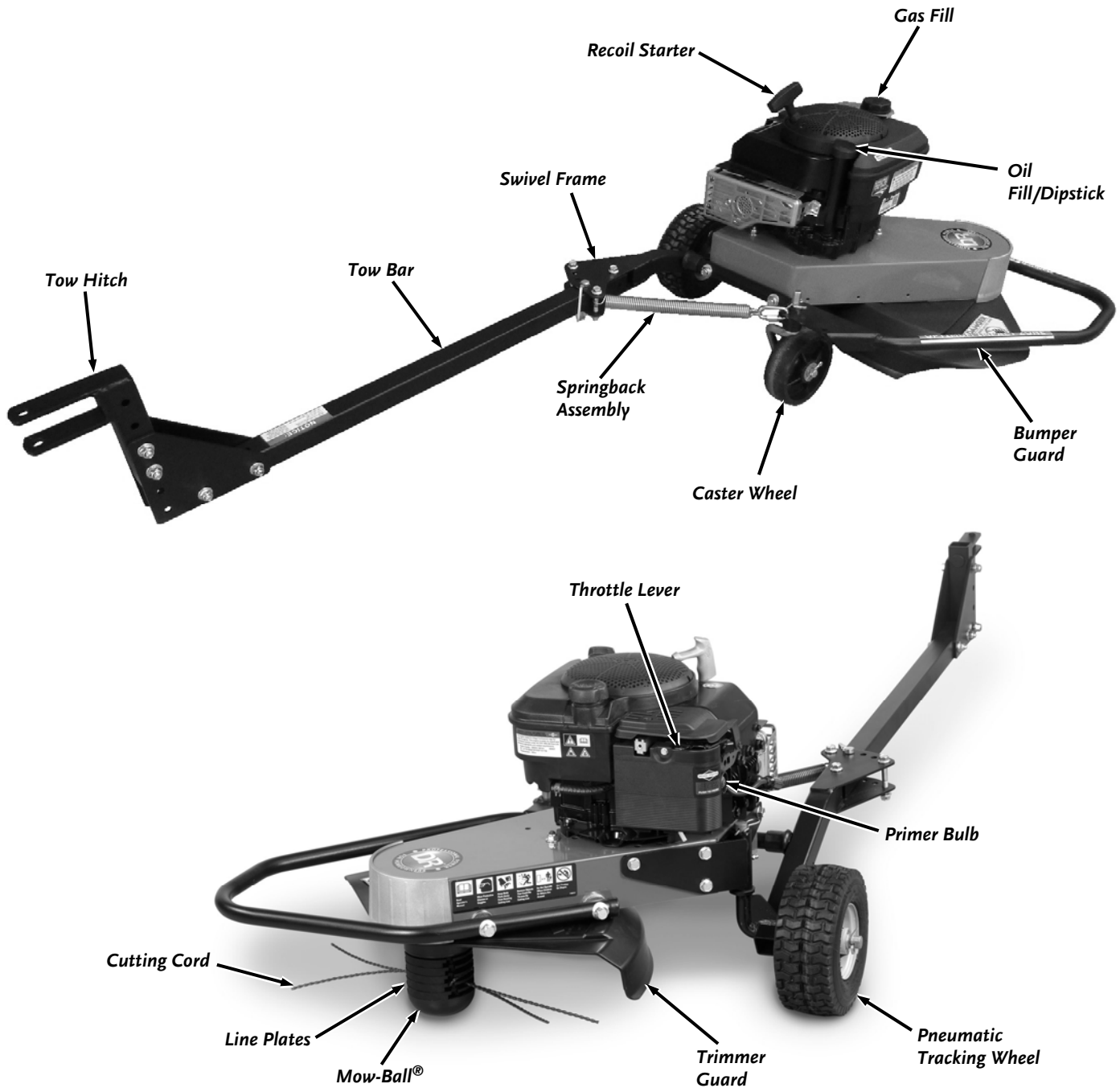

Figure 1

Specifications

Engine	625 Series Briggs and Stratton. See your Engine owner's manual for detailed Engine Specifications
Cutting Width	22"
Cutting Heights	2.7", 3.2", 3.7", 4.2", 4.7"
Cord Tip Speed (mph)	220
Cord Size	0.155" (Blue) or 0.175" (Green)
Offset Maximum Reach	POS #1: 29", POS #2: 40.5", POS #3: 51"
Frame	Welded Steel
Spindle Housing	Cast Aluminum
Spindle Shaft	Steel D Shaft
Drive Belt	Double V, AA62
Drive Engagement	Clutch Free Belt Drive
Cord Line Plates	5 Line Plates, 4" diameter
Mow-Ball	Heat, Impact, and UV-Resistant Polymer, 4"
Wheels	Pneumatic, 9 x 3.5-4", -Caster, Plastic, 6 x 2 x 5/8"
Machine Dimensions	66" L x 35" W x 21.5" H
Machine Weight	74 lbs.

Hardware Bag Parts (Figure 2 and Table Below)

Item	Part no.	Description	QTY
1	33348	Bolt, Hex, Flange, 3/8-16 X 2.5"	7
2	21155	Pin, Snap Safety, 3/8" X 2.75"	1
3	18967	Washer, Flat, Neoprene, .490" ID X 1.06" OD X .09" TH	1
4	21154	Pin, Clevis, 1/2" OD X 3.5" LG	1
5	16003	Pin, Hair, 1/2" To 9/16", .12" Wire	2
6	33443	Link, Chain, Threaded Connector, 9/16" ID, 1/4" TH	1
7	12685	Pin, Cotter, 3/16" X 1.5"	3
8	33333	Nut, Nylon Lock, Flanged, 3/8-16	7
9	34147	Spring, 1" Diam. X 9" L X .095" TH	1
10	15745	Washer, Flat, 5/8", USS	2

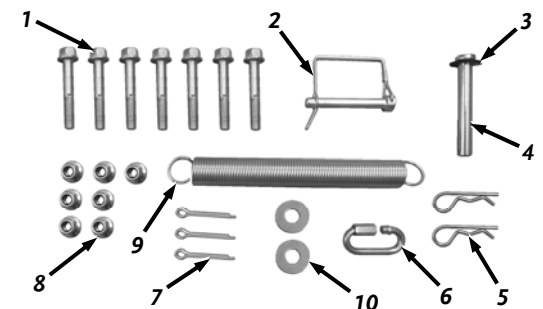

Figure 2

Parts Box (Figure 3 and Table Below)

Item	Part no.	Description	QTY
1	337631	Swivel Frame	1
2	279331	Bracket, Hitch Adjustment	2
3	337701	Caster, Yoke	1
4	254891	Hitch Assembly	1

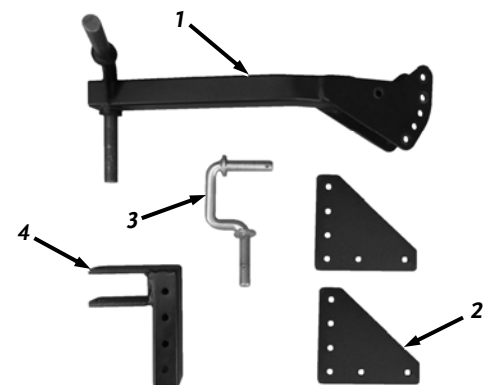

Figure 3

Compare the contents of the Hardware Bag and Parts Box with the lists and photos above. If you have any questions please contact us at www.DRpower.com or call 1-800-DR-OWNER (376-9637) for assistance.

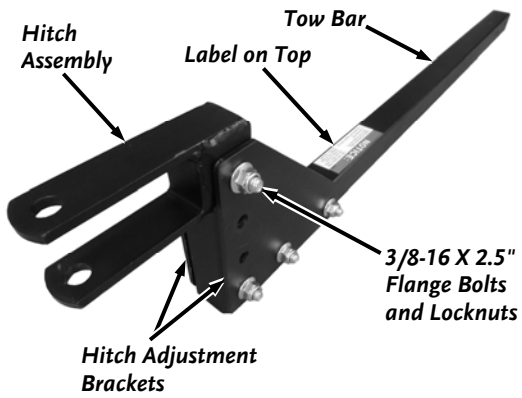

Figure 4

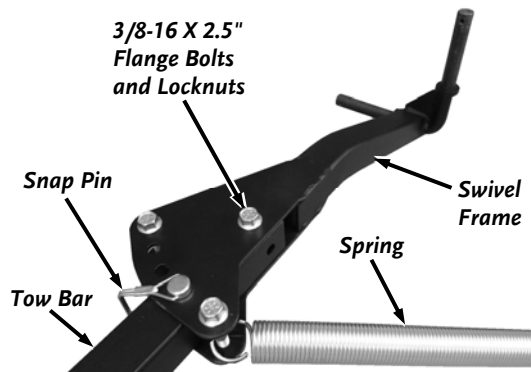

Figure 5

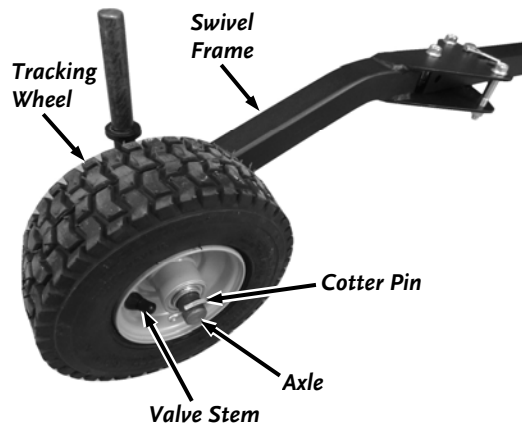

Figure 6

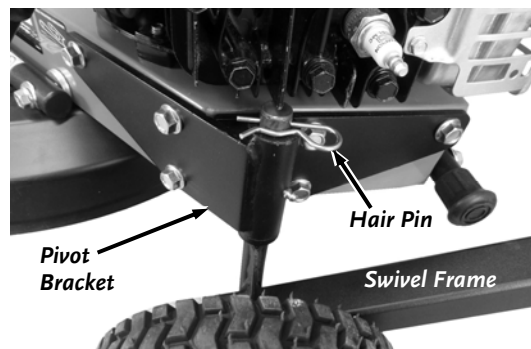

Figure 7

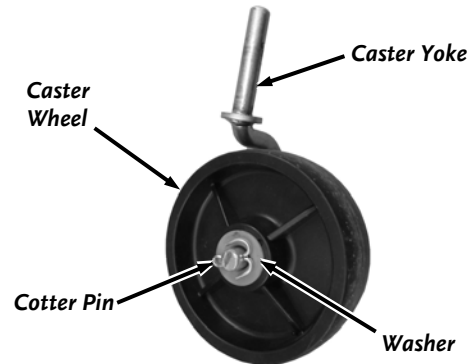

Figure 8

Assembly

Tools needed:

- Two 9/16" Wrenches
- Pliers

Note: Ensure that the "Notice" Label is facing up for the following procedures. The four holes in a row on the Hitch Adjustment Brackets will face forward for Hitch Assembly mounting.

1. Loosely assemble the Hitch Assembly to the Hitch Adjustment Brackets with two Flange Bolts and Locknuts by hand (**Figure 4**).
2. Loosely assemble the Tow Bar to the Hitch Adjustment Brackets with two Flange Bolts and Locknuts by hand. Tighten all four sets of hardware using two 9/16" Wrenches.

Note: Only tighten the hardware until it is snug against the Swivel Frame but still allows the Tow Bar to pivot side to side in the following steps. Over tightening may cause binding when offsetting the Tow Bar.

3. Secure the Tow Bar to the Swivel Frame with a Flange Bolt and Locknut at the end of the Tow Bar and the Snap Pin in the forward hole location (**Figure 5**).
4. Install a Flange Bolt and Locknut on the right hand side of the Swivel Frame using two 9/16" Wrenches.
5. Position the Spring end and install a Flange Bolt and Locknut on the left hand side of the Swivel Frame and through the Spring using two 9/16" Wrenches.
6. Slide the Tracking Wheel onto the Swivel Frame Axle (Valve Stem facing out) and secure with a Cotter Pin using Pliers (**Figure 6**).
7. Insert the Swivel Frame Shaft into the Frame Pivot Bracket and secure with a Hair Pin (**Figure 7**).
8. Place the Caster Wheel onto the Caster Yoke and secure with a 5/8" Washer and Cotter Pin using Pliers (**Figure 8**).

9. Insert the Caster Yoke pivot into the Caster Bracket and secure with a 5/8" Washer and Cotter Pin using Pliers (*Figure 9*).
10. Install the Chain Link into the inside hole of the Caster Bracket and place the end of the Spring into the Link (*Figure 10*). Close the Link to secure the Spring.

Greasing the machine before use

Tools and supplies needed:

- Grease Gun with General Purpose Grease
1. Apply three to four pumps of Grease to the Pivot Shaft Grease Fitting (*Figure 11*).
 2. Apply three to four pumps of Grease to the Tracking Wheel Grease Fitting (*Figure 12*).

Check the Tire Pressure

Tools Needed:

- Tire Pressure Gauge
 - Air Compressor
1. Remove the Valve Stem Protective Cap (*Figure 13*) and check the tire pressure with a Tire Pressure Gauge.
 2. Check what the manufacturers recommended pressure is that is stamped on the side of the Tire.
 3. If the pressure is too low, add air through the Valve Stem with an air hose.
 4. Replace the Valve Stem Protective Cap when finished.

WARNING

Do not over inflate the tires. Inflate to the manufacturers recommended pressure found on the tires.

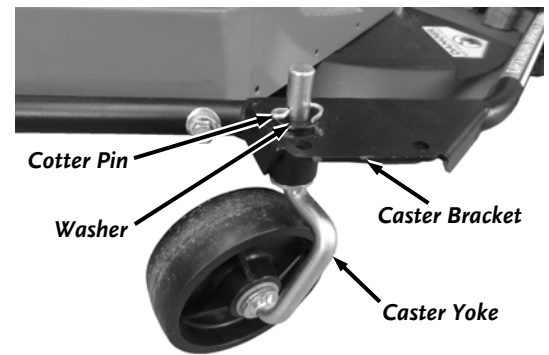

Figure 9

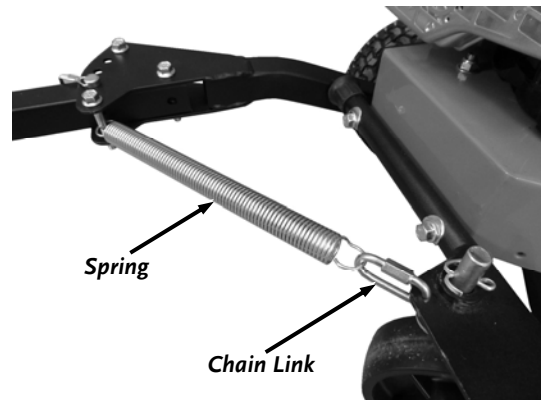

Figure 10

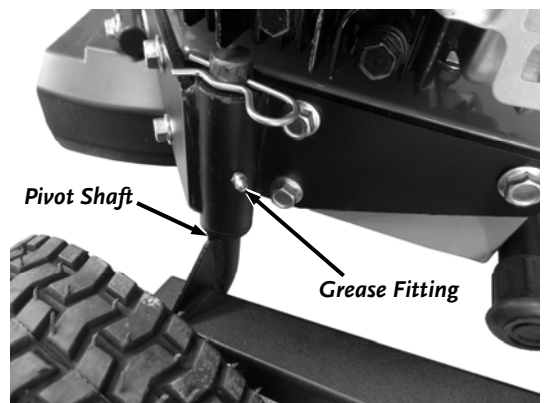

Figure 11



Figure 13

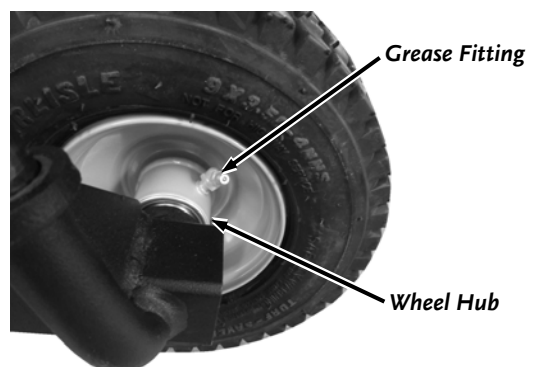

Figure 12

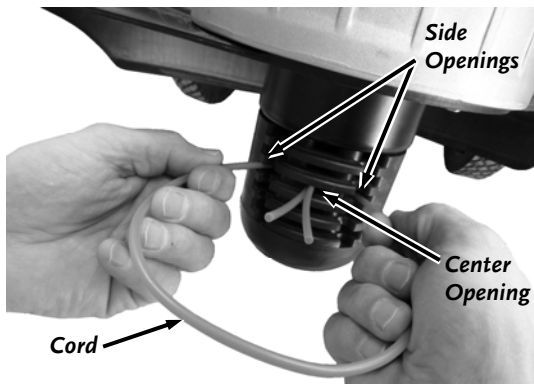

Figure 14

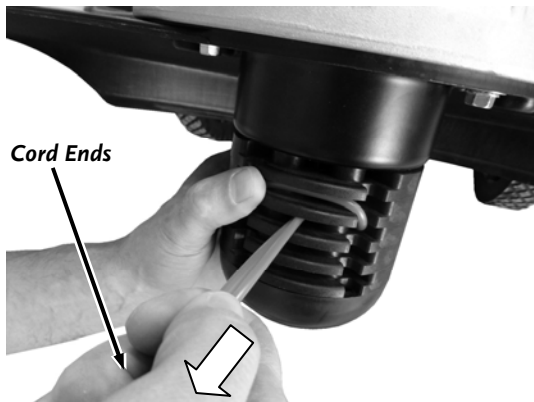

Figure 15

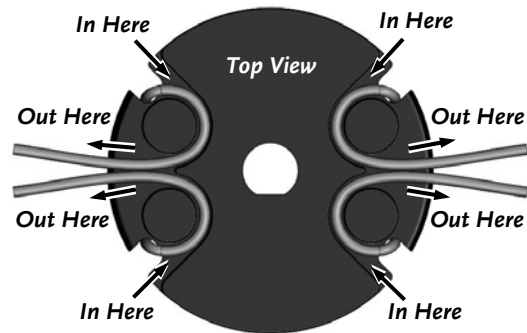

Figure 16

Installing the Cutting Cords

There are two installation points on each Line Plate. Each point is 180 degrees apart. Always install two Cords, one opposite the other at the same height. If you buy Cutting Cord in rolls, cut it in 25" lengths. Cut them at an angle so they will be easier to install.

Note: Soaking the Cutting Cords in water and trimming the ends at an angle will make installation easier.

1. Insert the ends of the Cords into the side openings in the Line Plate (**Figure 14**).
2. Push the Cord through until the ends come out the center hole in the Line Plate. Adjust the Cords so the tips are even.
3. Pull the Cords under the loop and push the loop up into the Line Plate groove above them (**Figure 15**) and then pull the Cords tight.

Figure 16 illustrates the Cords installation on the Line Plates. It shows the Line Plate from a top view. It may look complicated, but once you have done it a couple of times, it's easy. There are two installation points on each Line Plate. Each point is 180 degrees apart. Always install two Cords, one opposite the other.

NOTICE

If the tips of the cords are not even, it can cause unbalance of the trimmer and will result in increased vibration.

Extending Cutting Cord Life

- **STORE YOUR CORD OUT OF THE SUN.** UV can damage your cord causing premature wear.
- **KEEP YOUR CORD HYDRATED.** Soak your cord in water for at least 3 days before using.

Adding Oil and Gasoline

Note: Refer to the Engine Manufacturers Manual for more detailed Engine information.

Tip: To avoid confusion, we recommend leaving the caps ON the Fuel and Oil Fills until you are ready to pour either gasoline or oil into the correct Fill.

Note: You will need approximately 15 to 22 ounces of SAE 30 high detergent oil depending on Engine type. Use only SAE 30 high detergent oil classified "For Service SF, SG, SH, SJ" or higher. Do not use special additives. Other types of oil could cause problems with the operation of your machine. Please refer to your Engine Owner's Manual for detailed information on oil quantity and cold temperature oil specifications.

NOTICE

- You must add oil before starting the engine. This machine is shipped without oil. Traces of oil may be in the reservoir from factory testing, but **you must add oil before starting the engine.** Fill the reservoir slowly, checking the level frequently to avoid overfilling.
- To get an accurate reading when checking the oil level:
 - the machine should be on a level surface.
 - the dipstick should be screwed down to ensure an accurate oil level reading.

1. Place the machine on a level surface and adjust the Tow Hitch as needed so the Frame and Engine are level.
2. Initially add 1/2 of the SAE 30 High Detergent oil into the Oil Fill (**Figure 17**) and wait one minute for the oil to settle.
3. Check the Dipstick and continue adding a few ounces of oil at a time, rechecking the Dipstick until the oil reaches the fill mark. Be careful not to overfill.
4. Fill the Fuel Tank with fresh, unleaded gas (with a minimum of 87 Octane), to not more than 1/4" from the bottom of the Fill Neck to allow for Fuel expansion. Be careful not to overfill and reinstall the Cap before starting the Engine. See your Engine Owner's Manual for more information.

Note: To refill the Fuel Tank, turn the Engine OFF, and let the Engine cool at least two minutes before removing the Fuel Fill Cap.

Installing the Spark Plug Wire

1. Install the Spark Plug Wire onto the Spark Plug (**Figure 18**).

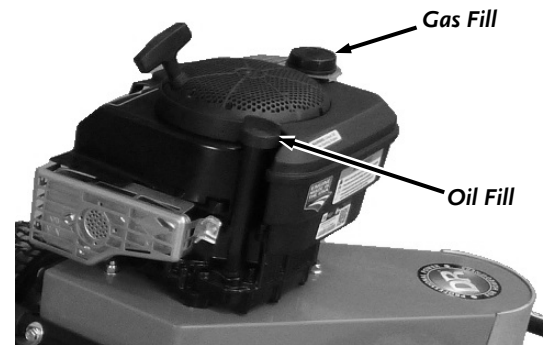

Figure 17

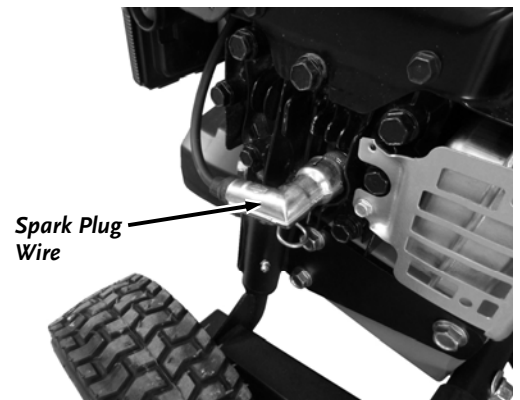

Figure 18

Chapter 3: Operating the DR 6.25 TOW-BEHIND TRIMMER/MOWER

! WARNING

- This machine is designed to operate at full throttle for desired trimming quality. Never trim at a slower speed; doing so can cause stress to the drive system and could cause damage to the machine that is not covered under warranty.
- Read and understand your Tow Vehicle user's manual and all safety Warnings for operating your Tow Vehicle safely before operating this DR 6.25 TOW-BEHIND TRIMMER/MOWER.

Operation Notes

- See the Owner's Manual that came with your Tow Vehicle for all safety warnings and detailed information for operating your Tow Vehicle properly.
- Do not exceed 1-3 mph when trimming to allow proper cutting and discharge of material.
- Do not exceed 5 mph when transporting to prevent damage to the machine.
- Always operate the Trimmer Engine at full throttle when trimming.
- Always lock the Parking Brake and shut off the Tow Vehicle when leaving the Seat.
- Never transport the Trimmer while the Trimmer Engine is running.
- Be cautious when trimming in reverse and do not hit any obstacles. The machine is designed to spring out of the way when hitting obstacles in the forward direction, not the reverse direction. If you hit obstacles with the Trimmer in the reverse direction the trimmer could be damaged and is not covered by the Warranty.
- Remove any debris buildup from the machine before every use of the Trimmer.

Preparing the Trimmer/Mower for Trimming

The characteristics of cutting height and quality are controlled by a combination of the Trimmer Cord height and tow speed. It takes time and practice to learn what the best combinations of settings for different conditions are.

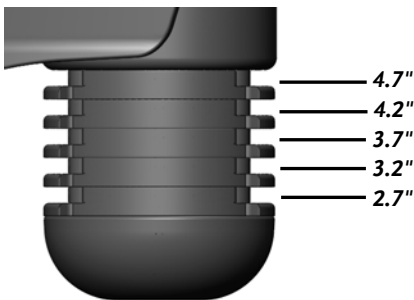

Figure 19

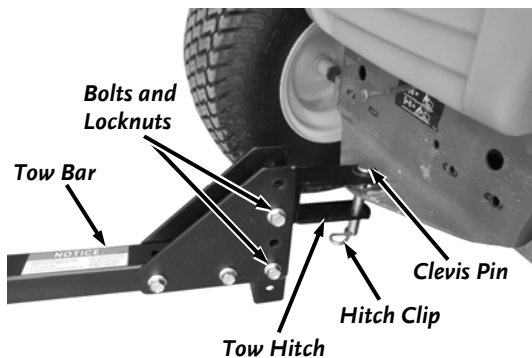

Figure 20

! WARNING

Never perform the following adjustments when the Engine is running. Always shut off the Trimmer Engine before making adjustments to avoid injury.

Adjusting the Cord Cutting Height

Setting the Cutting Height is easy. Cutting heights range in 1/2-inch increments from 2.7 inches (minimum) when using the bottom Line Plate, to approximately 4.7 inches when using the top Line Plate (**Figure 19**). Install the Cutting Cords in the Line Plate that gives you the desired cutting height.

Hitching the Trimmer to the Tow Vehicle

1. Position the Tow Hitch onto the Tow Vehicle Hitch and secure with the clevis Pin and Hitch Clip (**Figure 20**).

Leveling the Trimmer

Tools and Supplies Needed:

- Two 9/16" Wrenches

Note: The Trimmer must always be leveled when attaching to a Tow Vehicle for proper operation.

1. Remove the two Bolts and Locknuts that secure the Hitch to the Tow Bar and position the Hitch at the desired setting to level the machine (**Figure 20**).

2. Install the two Bolts and Locknuts and tighten with two 9/16" Wrenches.

Note: The Tow Hitch can be rotated to position the Clevis Pin holes at the top or bottom depending on how much adjustment you need to adjust the Tow Bar to level the machine.

Adjusting the Tow Bar Offset

The Tow Bar offset adjusts the trimming distance from the center of the Tow Vehicle. The straight in line position trimming distance is 29". The first offset position will trim a distance of 40.5". The second offset position will trim a distance of 51".

Note: This procedure is easier with the Trimmer disconnected from the Tow Vehicle.

1. Disconnect the Trimmer from the Tow Vehicle.
2. Remove the Snap Safety Pin that is securing the Swivel Frame to the Tow Bar (Figure 21).
3. Move the Tow bar to the desired offset position, align the holes and reinstall the Snap Safety Pin (Figure 22).
4. Reattach the Trimmer to the Tow Vehicle.

Adjusting the Kickback Spring tension

If you prefer to have the kickback function return quicker or are trimming thicker material, the Chain Link can be moved to the outer position to create more tension.

Tools and Supplies Needed:

- 7/16" Wrench

Loosen the Chain Link using a 7/16" Wrench and move the Chain Link and Spring to the outer hole location to increase Spring tension for a quicker return (Figure 23).

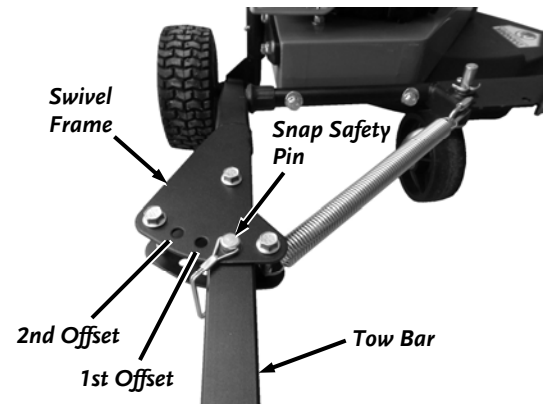

Figure 21

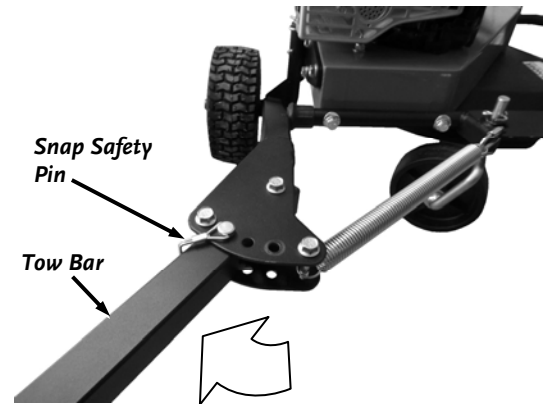

Figure 22

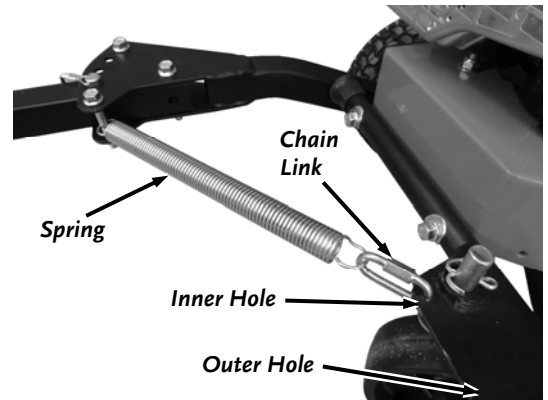

Figure 23

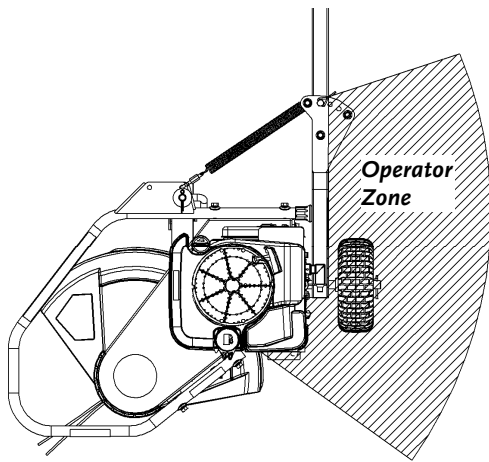

Figure 24

Starting the Engine and Trimmer Head

See Engine owner's manual for more detailed starting information.

! WARNING

- When using the Trimmer, make sure you are standing in the safe operating area (OPERATOR ZONE) as shown in **Figure 24**. You must stay in the safe operating area at all times when starting or stopping the machine.
- The Trimmer Head is always spinning when the Engine is running. Stay away from the Trimmer Head area when the Engine is running or you could be injured by the spinning Cords.

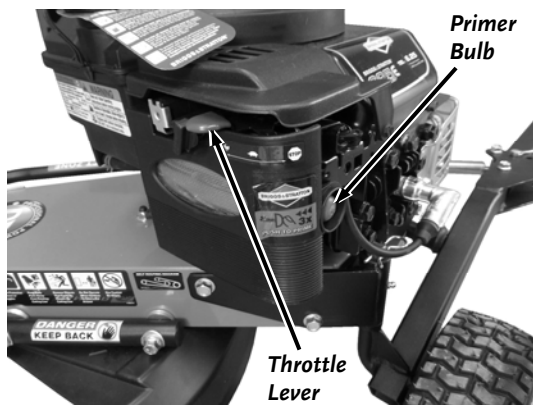

Figure 25

1. Push the Throttle Control Lever all the way to the left (Rabbit position) (**Figure 25**).

2. Push the Primer Bulb in and release three times.

Note: "Priming" the Engine is usually not necessary when restarting a warm Engine.

3. Grasp the Recoil Starter Handle and slowly pull until you feel resistance (**Figure 26**). Let the cord retract a little bit and then pull the cord rapidly to start the Engine. One or two pulls usually starts the DR 6.25 TOW-BEHIND TRIMMER/MOWER.

Stopping the Engine and Trimmer Head

1. Move the Throttle Control Lever all the way back past the TURTLE (Slow) position to the "STOP" position.

Obstacles

Dealing with obstacles in the terrain is easy with your new DR 6.25 TOW-BEHIND TRIMMER/MOWER. The following section explains how to approach most common obstacles.

- Always check your work area before trimming and remove any debris that might tangle or damage the machine.

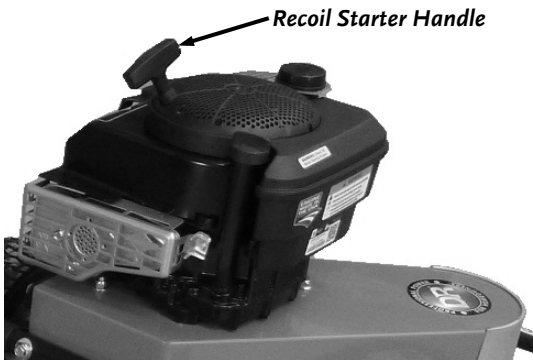

Figure 26

- Approach obstacles (Buildings, fence posts, Trees, Large Rocks etc) so the impact zone will be within the area of the Optimum Impact Zone Label (**Figure 27**). This will ensure the best spring action and trimming coverage around the obstacle.
- If you do run into debris and the Trimmer becomes tangled, Shut off the Tow Vehicle, set the parking brake and remove the Key. Shut off the Trimmer Engine and after all moving parts to come to a complete stop, wait five minutes for parts to cool before attempting to untangle the machine.
- Be cautious when trimming in reverse and do not hit any obstacles. The machine is designed to spring out of the way when hitting obstacles in the forward direction, not the reverse direction. If you hit obstacles with the Trimmer in the reverse direction the trimmer could be damaged and is not covered by the Warranty.

Heavy Growth

- Take your time in heavy growth.
- If the machine cannot do it all in one pass, overlap half of the cutting swath.
- Ease the DR 6.25 TOW-BEHIND TRIMMER/MOWER into denser growth. If the material is too tough or woody to cut, the Cutting Cords will wrap around it, wear down, or even break off.

Tip: Use the “two pass”, one half overlap method, whenever possible.

Slopes

Refer to your Tow Vehicle Users Manual for slope safety information and slope operation guidelines for the Tow Vehicle. Never exceed 20 degrees slope for the DR 6.25 TOW-BEHIND TRIMMER/MOWER. Whenever possible, try to trim with the Trimmer Head DOWN HILL from the machine.

Windrows

The DR 6.25 TOW-BEHIND TRIMMER/MOWER Cutting Cords cut even tall grass in just one pass, so you can collect clippings and leaves for mulch without raking. The machine ejects cut material to its left side, so you can use it like a lawn broom to make windrows for easy clean-up.

Cord Tips

We ship two thicknesses of Cutting Cord with your DR 6.25 TOW-BEHIND TRIMMER/MOWERS. The Cords are Blue (175-mil) and Green (155-mil). Because conditions and vegetation vary, you should experiment with Cord weights (diameters) to discover what works best for your particular mowing and trimming situations. Here are a few things to keep in mind:

- If you buy Cutting Cord in rolls, cut it in 25" lengths. Cut them at an angle so they will be easier to install.
- Soak your Cutting Cord in a bucket of room temperature water for a few days before use to make it more pliable. Storing the Cord in a plastic bag with a damp sponge or cloth will help keep it pliable
- Cord life depends on trimming conditions. Replace Cords when they become broken or frayed.
- The smallest diameter Cord capable of cutting the material at hand usually provides the best grass trimming performance. When you need more strength for thicker growth such as berry canes, brambles, thistles, or ragweed, you may want to use the 175-mil Cord.
- Ease the ends of the Cord into heavy growth and move slowly through thick growth. If there are woody weeds in the material you are cutting, the cutting Cords may wrap around the stalks they cannot cut, and pull away from the Trimmer Head.
- If the Cord breaks off flush at the Line Plate, use needle nose pliers to pull out the old Cord.
- UV light can degrade cord, store out of direct sunlight.

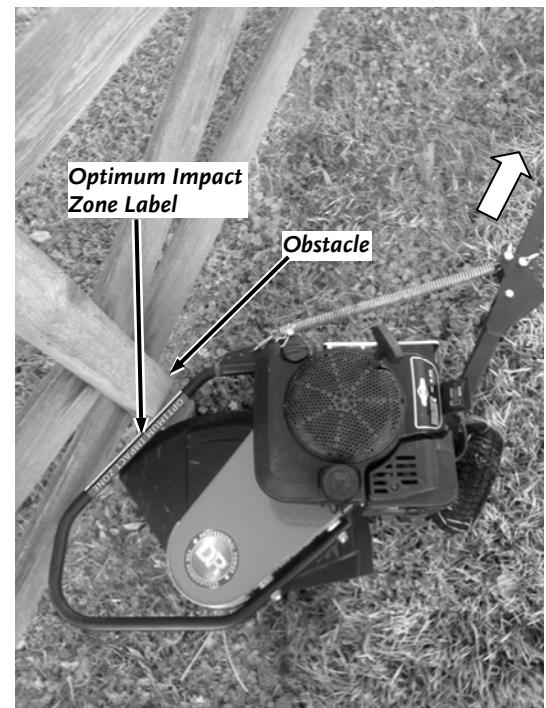

Figure 27

Chapter 4: Maintaining the DR 6.25 TOW-BEHIND TRIMMER/MOWER

Regular maintenance is the way to ensure the best performance and long life of your machine. Please refer to this manual for maintenance procedures.

⚠ WARNING

Shut off the Tow Vehicle, set the parking brake and remove the Key. Shut off the Trimmer Engine and after all moving parts to come to a complete stop, wait five minutes before performing any maintenance procedure or inspection on the Trimmer.

Regular Maintenance Checklist

Note: Consider that the service intervals shown are the maximum under normal operating conditions. Increase frequencies under extremely dirty or dusty conditions.

PROCEDURE	BEFORE EACH USE	EVERY 20 HOURS	EVERY 50 HOURS	EVERY 100 HOURS
Check Engine Oil Level.	▲			
Clean Engine Exterior, Cooling Fins and remove collected grass trimmings.*	▲			
Check General Equipment Condition, e.g. Nuts, Bolts, Welds, etc.	▲			
Replace broken or frayed Cutting Cords.	▲			
Check the Mow-Ball® for excessive wear.	▲			
Check the Trimmer Belt for damage.	▲			
Change the Engine Oil	1 st time 5 hours	▲		
Replace the Engine Air Filter Cartridge and foam Pre Filter if equipped.		▲		
Replace the Trimmer Belt		▲		
Clean and inspect Trimmer Head assembly			▲	
Replace the Spark Plug.				▲

* Cleaning the top of the Engine during use is critical for proper air flow. Keeping the Engine clear of debris is necessary for optimum performance.

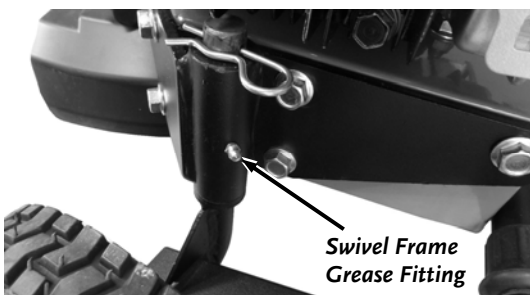

Figure 28

Greasing the Tracking Wheel and Support

Tools needed:

- Grease gun
- Lithium grease
- Clean cloth

1. Apply general-purpose lithium grease to the Swivel Frame Grease Fitting (**Figure 28**).

1. Apply general-purpose lithium grease to the Tracking Wheel Grease Fitting using a grease gun (**Figure 29**).

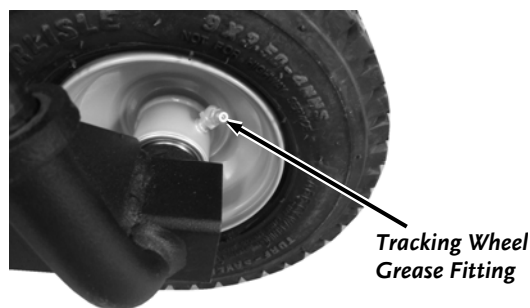

Figure 29

Replacing the Mow-Ball® or Line Plates

Tools and Supplies Needed:

- Phillips head Screwdriver with at least a 6" shank
 - Gloves
2. Align the hole in the Anti Wrap Canister with the hole in the internal housing at the location shown (**Figure 30**).
 3. Insert a Philips Head Screwdriver into the hole in the Anti Wrap Canister and the hole in the internal Housing.
 4. Rotate the Mow-Ball® Assembly until the Screw Driver slides into a hole in the shaft, locking it into place.
 5. Looking down at the top of the Frame, turn the Mow-Ball® counter clockwise until it unscrews completely from the Bearing Housing.

Note: If the Mow-Ball® continues to turn, but does not come off, check to be sure that you locked the Screwdriver into the shaft.

If the Mow-Ball will not turn by hand a 9/16" Socket can be used on the Bolt (inside the bottom of the Mow-Ball) to loosen it. You may need to clean grass or debris out of the recess first.

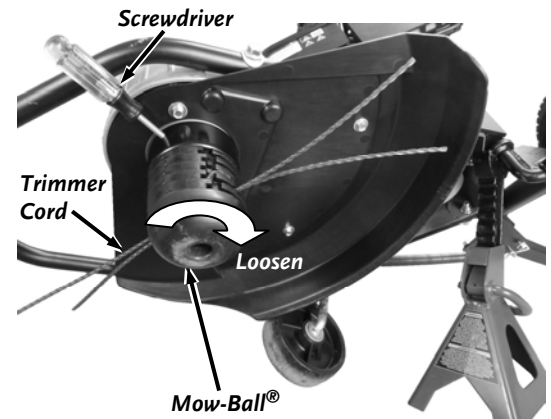

Figure 30

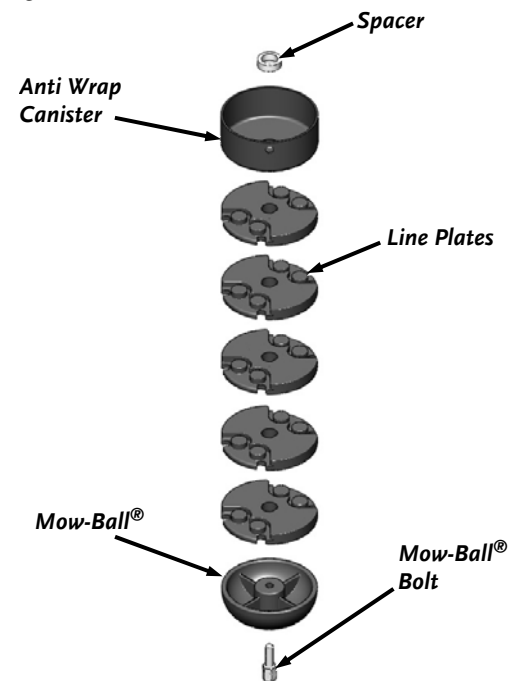

Figure 31

NOTICE

Improper installation can cause damage to the trimmer bearings. Follow these directions carefully to protect your machine from damage. Reassemble the components in the order shown in **figure 31**.

6. Slide the Line Plates off the Shaft.
7. Place the Spacer and Anti Wrap Canister (with the lip facing up) onto the Shaft (**Figure 31**).
8. Align the flats at the center of the Plates with the flat on the shaft and slide the Line Plates onto the Shaft. Ensure they are facing top side up as shown.
9. Place the head of the Mow-Ball® Bolt so it is sitting in the hex cavity at the bottom of the Mow-Ball®.
10. Looking down at the top of the Frame, hold the Bolt Head in place with your finger and turn the Mow-Ball® counterclockwise to start the Bolt into the Shaft. The Bolt has a left hand thread.
11. Tighten the assembly securely by turning the Mow-Ball® clockwise when looking down on the top of the Frame.
12. Remove the Screwdriver.

Note: When finished there should be no gaps between any of the components.

WARNING

Always make sure you remove the screwdriver from the head assembly when finished. Failure to remove the screwdriver could cause injury when the head assembly is engaged.

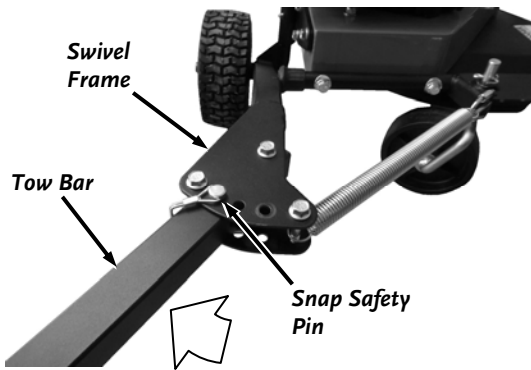

Figure 32

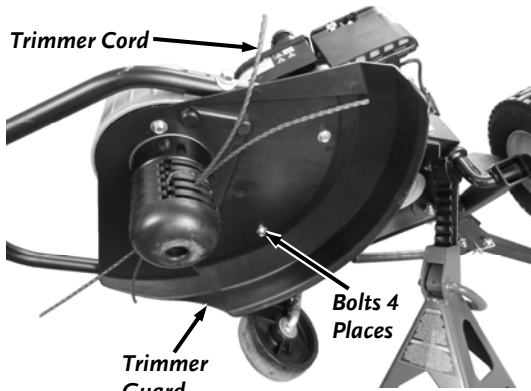

Figure 33

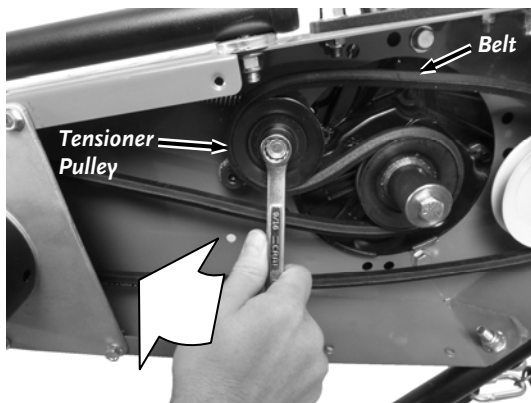

Figure 34

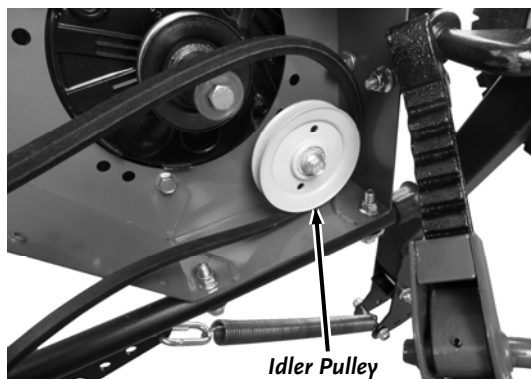

Figure 35

Replacing the Drive Belt

Tools needed:

- 3/8" Wrench
- Two 9/16" Wrenches

1. Set the Tow-Bar offset to the furthest offset position by removing the Snap Safety Pin and rotating the Tow Bar to the far right (**Figure 32**). Reinstall the Snap Safety Pin through the holes in the Tow Bar and Swivel frame.
2. Lift the right side of the machine up and support it with a Jack stand (**Figure 33**).
3. Remove the Trimmer Cord from the Head.
4. Remove the four Trimmer Guard Bolts using a 3/8" Wrench and remove the Guard.

Note: In the next step, the Wrench is only used to rotate the Idler Arm to loosen Belt tension, not to loosen the hardware.

5. Use a 9/16" Wrench on the hardware and pull the Tensioner Pulley back to release the Belt from the Pulley (**Figure 34**).
6. Use two 9/16" Wrenches to loosen the Idler Pulley enough so the Belt to be released from the Pulley (**Figure 35**). Remove the Belt from the machine.
7. Install a new by following the steps in reverse order.

Note: When positioning the new Belt, make sure that it is not twisted and the "flat" is facing inside the Pulley with the raised "rib" facing up toward the Frame and the other side facing down toward the ground (**Figure 36**).

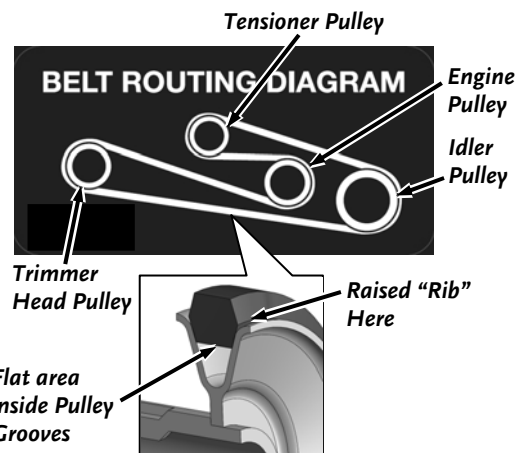

Figure 36

Replacing the Tracking Wheel

Tools Needed:

- Pliers

1. Remove the Cotter Pin with Pliers and remove the Tracking Wheel Assembly (**Figure 37**).
2. Install the new Tracking Wheel Assembly with the Valve Stem facing out.
3. Secure with the Cotter Pin.

Replacing the Tracking Wheel

Tools Needed:

- Pliers

1. Remove the Cotter Pin with Pliers and remove the Caster Wheel Assembly (**Figure 38**).
2. Install the new Wheel Assembly.
3. Secure with the Cotter Pin.

Check the Tire Pressure (Tracking Wheel)

Tools Needed:

- Tire Pressure Gauge
- Air Compressor

1. Remove the Valve Stem Protective Cap (**Figure 39**) and check the tire pressure with a Tire Pressure Gauge.
2. Check what the manufacturers recommended pressure is that is stamped on the side of the Tire.
3. If the pressure reading is too low, add air through the Valve Stem with an air hose.
4. Replace the Valve Stem Protective Cap when finished.

WARNING

Do not over inflate the tires. Inflate to the manufacturers recommended pressure found on the tires.

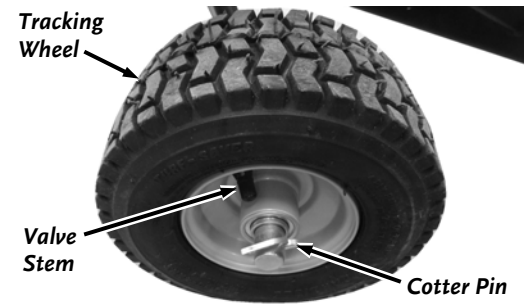

Figure 37

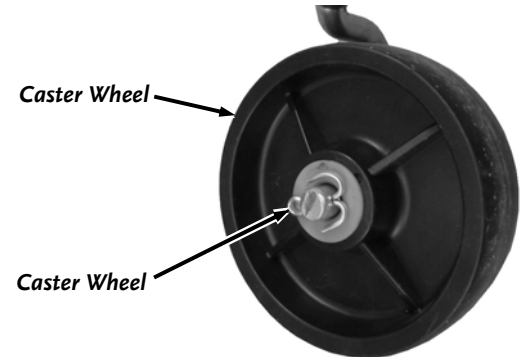

Figure 38



Figure 39

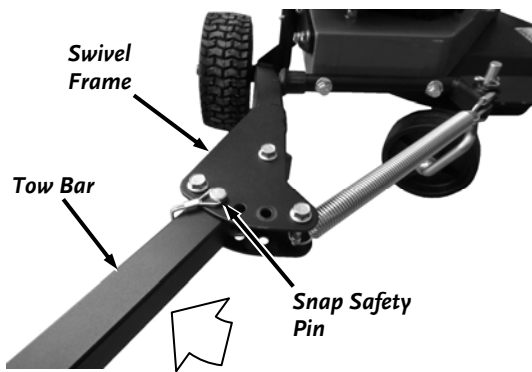

Figure 40

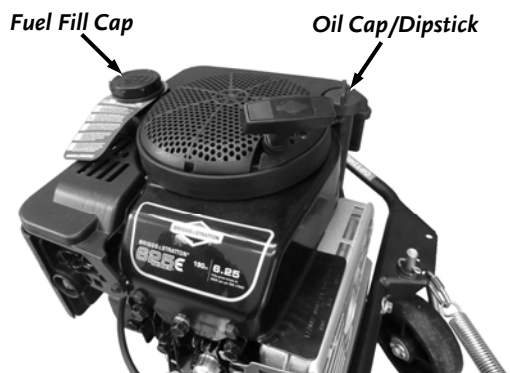

Figure 41

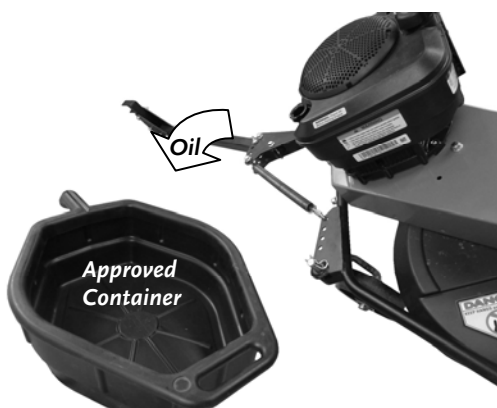

Figure 42

Changing the Engine Oil

The Engine on your machine is not equipped with an Oil Drain Plug and will require some disassembly to fully drain the Oil. There is however, an Oil Suction Pump available to make removing the Oil easier. Please visit our web site at www.DRPower.com or call 1-800-DR-OWNER (376-9637) for assistance.

Tools and Supplies needed:

- SAE 30 HD Oil (refer to your Engine Owner's Manual for quantity required)
- Suitable container for used oil
- Rags

Note: Drain the oil when the Engine is warm. Warm oil drains quickly and completely.

1. Set the Tow-Bar offset to the furthest offset position by removing the Snap Safety Pin and rotating the Tow Bar to the far right (**Figure 40**). Reinstall the Snap Safety Pin through the holes in the Tow Bar and Swivel frame.
2. Make sure to securely tighten the Gas Fill Cap (**Figure 41**).
3. Remove the Oil Cap/Dipstick and position a suitable oil receptacle beside the Oil Fill Tube (**Figure 42**).
4. Tip the Trimmer to drain the oil out through the Oil Filler Tube.
5. Lower the Trimmer when finished and refill the Engine with Oil as described in the "Adding Oil and Gasoline" section in Chapter 2.

Note: Be sure to use environmentally safe disposal procedures in the disposing of the used oil.

Storage

It is quick and easy to partially disassemble the machine to take up less space when stored.

Tools Needed:

- 7/16" Wrench

1. Loosen the Chain Link using a 7/16" Wrench and remove the Chain Link from the Frame (**Figure 43**).
2. Pull the Hair Pin from the Swivel Frame Shaft and remove the Swivel Frame from the Machine (**Figure 44**).

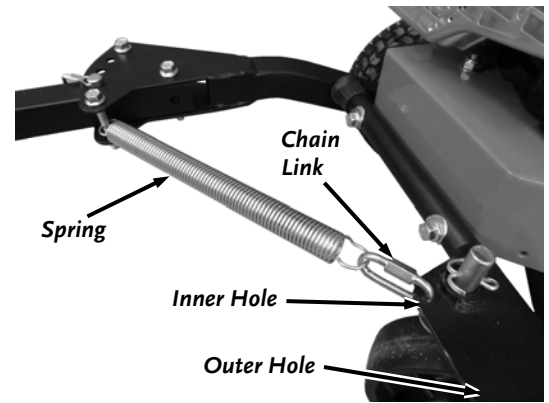

Figure 43

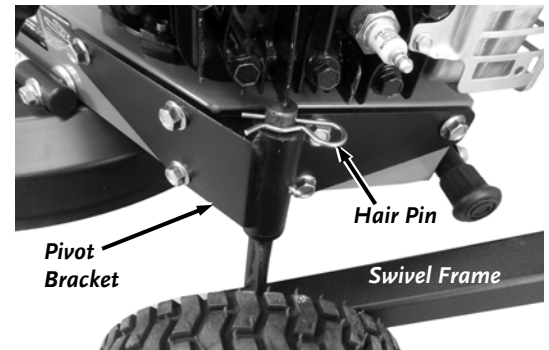

Figure 44

Chapter 5: Troubleshooting

Most problems are easy to fix. Consult the Troubleshooting Table below for common problems and their solutions. If you continue to experience problems, contact us at www.DRpower.com or call toll-free 1-800-DR-OWNER (376-9637) for support.

WARNING

Shut off the Tow Vehicle, set the parking brake and remove the Key. Shut off the Trimmer Engine and after all moving parts to come to a complete stop, wait five minutes for the machine to cool and disconnect the spark plug wire, keeping it away from the spark plug before performing any maintenance procedure or inspection on the Trimmer.

Troubleshooting Table

SYMPTOM	POSSIBLE CAUSE
<i>Recoil will not pull out or is difficult to pull.</i>	<ul style="list-style-type: none"> ⇒ Check the Engine oil level, the Engine may be seized. ⇒ There may be an oil compression lock in the Cylinder. Take out the Spark Plug; hold a rag over the Spark Plug hole and pull the Recoil Cord several times to blow out any oil in the Cylinder. Wipe off the Spark Plug and reinstall it. ⇒ The Recoil may be broken or jammed. Try to turn the Engine by rotating the Trimmer Head with the Spark Plug removed. If it turns, the Recoil is broken or jammed. Visit our web site at www.DRPower.com or call 1-800-DR-OWNER (376-9637) for assistance.
<p><i>The Engine will not start.</i></p> <p><i>(Please refer to the Engine Owner's Manual for Engine-specific procedures.)</i></p>	<ul style="list-style-type: none"> ⇒ Check that the Throttle is in the fast (rabbit) position. ⇒ Check that you have pushed and released the Primer Bulb at least three times if the Engine is cold. ⇒ Check for proper attachment of the Spark Plug wire. ⇒ Check that the Engine has the right amount of clean oil. If the oil is dirty, change it following the procedure on page 20. ⇒ You should be using fresh, clean, unleaded gas. If the gas is old, change it. Use a fuel stabilizer if you keep gas longer than one month. ⇒ Check that the Air Filter is clean. If it is dirty, change it following the procedure in the Engine Owner's Manual. ⇒ Make sure that the Spark Plug is clean. If the Spark Plug is dirty or cracked, change it. If it's oily, leave it out, hold a rag over the Spark Plug hole and pull the Recoil Cord several times to blow out any oil in the Cylinder, then wipe off the Spark Plug and reinsert it. ⇒ If the Engine still will not start, visit our web site at www.DRPower.com or call 1-800-DR-OWNER (376-9637) for assistance.
<i>Engine smokes.</i>	<ul style="list-style-type: none"> ⇒ Check the oil level and adjust as needed. ⇒ You may be operating the machine on too great an incline. (See Slopes on page 15) ⇒ Check the Air Filter and clean or replace if needed. ⇒ You may be using the wrong oil - too light for the temperature. Refer to your Engine Owner's Manual for detailed information. ⇒ Clean the Engine cooling fins and the carburetor housing if they are dirty. ⇒ If the Engine still smokes, visit our web site at www.DRPower.com or call 1-800-DR-OWNER (376-9637) for assistance.

Troubleshooting Table (Continued)

SYMPTOM	POSSIBLE CAUSE
<p><i>The Engine lacks power or is not running smoothly.</i></p> <p><i>(Please refer to the Engine Owner's Manual for Engine-specific procedures.)</i></p>	<ul style="list-style-type: none"> ⇒ Check the Throttle Lever. The Throttle Lever should be in the fast (rabbit) position. ⇒ Check for debris (hay seed, etc.) clogging the Air Filter Intake and clean out as required. ⇒ The Engine's Blower Housing, Throttle Linkage, and Cooling Fins should be free of debris. Clean them following the instructions in the Engine Owner's Manual. ⇒ Check that the Air Filter is clean. If it is dirty, change it following the procedure in the Engine Owner's Manual. ⇒ Remove the Spark Plug wire and dry the connection with a rag. ⇒ The Spark Plug may be dirty or cracked, change it. If it's oily, leave it out, hold a rag over the Spark Plug hole and pull the Recoil Cord several times to blow out any oil in the Cylinder, then wipe off the Spark Plug and reinsert it. ⇒ You should be using fresh, clean, unleaded gas. If it is old, change it. Use a fuel stabilizer if you keep gas longer than one month. ⇒ Check that the Engine has the right amount of clean oil. If it is dirty, change it following the procedure on page 20. ⇒ If your Engine still lacks power, visit our web site at www.DRPower.com or call 1-800-DR-OWNER (376-9637) for assistance.
<p><i>The Trimmer Head won't spin or lacks power.</i></p>	<ul style="list-style-type: none"> ⇒ Check for proper alignment of the V-Belt. Check it by referencing Figure 36 in the "Replacing the Drive Belt" section on page 18. ⇒ The Belt may be worn or frayed; if so, replace it. ⇒ If none of the above helps, visit our web site at www.DRPower.com or call 1-800-DR-OWNER (376-9637) for assistance.
<p><i>Poor cut quality</i></p>	<ul style="list-style-type: none"> ⇒ Cord needs to be replaced. ⇒ Tow Vehicle speed too fast.
<p><i>Scalping</i></p>	<ul style="list-style-type: none"> ⇒ Tow Bar adjustment is not adequate to level the machine or the terrain is too uneven. Adjust Tow Bar to level the machine.
<p><i>Machine stops cutting</i></p>	<ul style="list-style-type: none"> ⇒ Inspect cords ⇒ Check belt tension/wear
<p><i>The Trimmer Head won't spin or lacks power.</i></p>	<ul style="list-style-type: none"> ⇒ Check for proper alignment of the V-Belt. Check it against the "Replacing the Drive Belt" section on page 18. ⇒ The Belt may be worn or frayed; if so, replace it. ⇒ If none of the above helps, visit our web site at www.DRPower.com or call 1-800-DR-OWNER (376-9637) for assistance.
<p><i>The Mow-Ball® is wearing too quickly.</i></p>	<ul style="list-style-type: none"> ⇒ You may be pushing the Trimmer Head down into the ground by the machine not being leveled to the height adjustment. Adjust the Tow Hitch so the Mow-Ball® is not touching the ground while trimming. ⇒ You may be hitting the Mow-Ball® against rocks, concrete driveways or other hard obstacles. Try approaching them slowly, and from different directions, to avoid unnecessary wear. ⇒ If none of the above helps, visit our web site at www.DRPower.com or call 1-800-DR-OWNER (376-9637) for assistance.

Chapter 6: Parts Lists and Schematic Diagrams

Parts List – Drive Assembly

Note: Part numbers listed are available through DR Power Equipment.

<u>Ref#</u>	<u>Part#</u>	<u>Description</u>	<u>Ref#</u>	<u>Part#</u>	<u>Description</u>
1	34123	Spindle, LH Thread	17	33333	Nut, Nylon Lock, Flanged, 3/8-16
2	31098	Can, Anti-Wrap	18	33775	Pivot, Bushing
3	31097	Plate, Line Spacer, D Bore	19	11238	Washer, Flat, 1/4"
4	31102	Cord Pack, 25", 12 Pcs	20	26535	Bolt, Shoulder, 1/2" X .75" L
5	31101	Mow Ball, Hex Bolt	21	34158	Engine, 6.25tq, 190cc, Briggs, MS, W/ Labels
6	34126	Bolt, 3/8-16 X 1", Gr5 ZP, High Head, Left Hand Thread	22	13758	Label, Check Oil, 2.75" x .63"
7	31099	Spacer, .680" X .984" X .310", ZP	23	33348	Bolt, Hex, Flange, 3/8-16 X 2.5"
8	31117	Screw, HWH, 1/4-20 X 3/4", Taptite	24	11914	Key, Sq, 3/16" X 1"
9	32200	Pulley, 3.5" ED, A-Profile V-Belt, .67" Shaft	25	34150	Bushing, 3/8" ID, 1/2" OD, .75" L
10	33438	Idler Bracket	26	31104	Guard, Trimmer
11	14409	Pulley, V-Belt, 2.625" O.D., Idler	27	13649	Label, Danger, Blade
12	34143	Pulley, Drive, A V-Belt, 7/8" Shaft	28	11241	Washer, Flat, 5/16" USS, ZP
13	33772	Belt, Double V, Aa62	29	34168	Bolt, HCS, 5/16-18 X 3/4", Left Hand, ZP
14	19351	Spring, Extension	30	34407	Bolt, Hex, Flange, 3/8-16 X 1.5", Gr5, ZP
15	11116	Pulley, Idler, Aa, V-Belt, 4" OD, 1/2" ID	31	28990	Bolt, Hex, Flange, Tri Lobe, 3/8-16 X 1", Gr5 ZP
16	11155	Bolt, HHCS 3/8-24 X .75", Gr.2, ZP			

Schematic – Drive Assembly

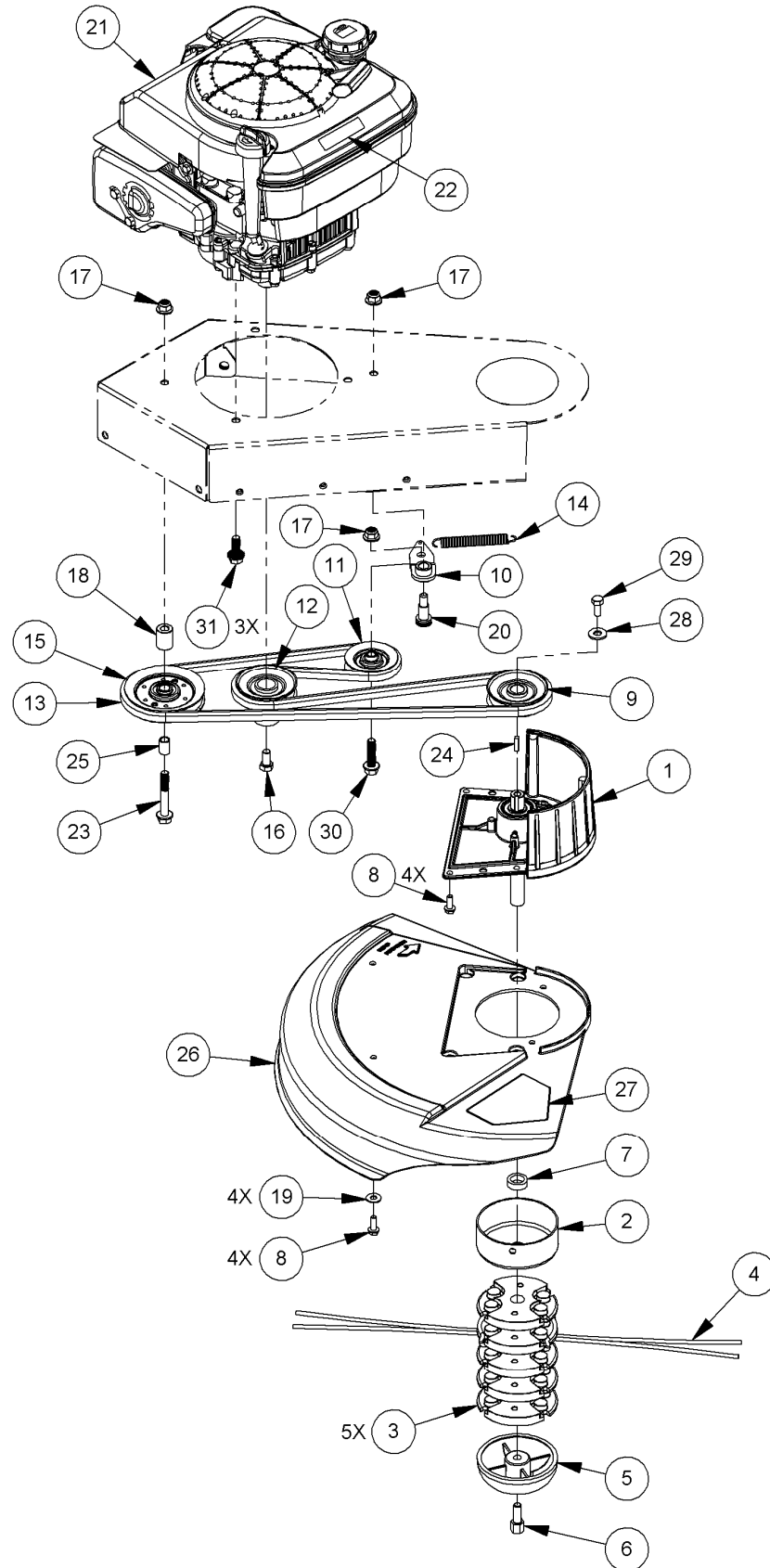

021114

Parts List – Frame and Tow-Bar Assembly

Note: Part numbers listed are available through DR Power Equipment.

<u>Ref#</u>	<u>Part#</u>	<u>Description</u>	<u>Ref#</u>	<u>Part#</u>	<u>Description</u>
1	34156	Frame, with Labels	17	34124	Bumper, Rubber, Push On
2	19202	Label, DR Logo, 4.0", 4 Color	18	28551	Washer, Saddle, 3/8 X 1"
3	14823	Label, Safety Icons	19	33350	Bolt, Hex, Flange, 3/8-16 X 2"
4	34167	Label, Belt Routing	20	33443	Link, Chain, Threaded Connector, 9/16" ID, 1/4" TH
5	34155	Towbar, with Labels	21	22887	Washer, .385" ID, 1.5" OD, .25" L, ZP
6	34149	Label, Warning, Towbar	22	15745	Washer, Flat, 5/8", USS
7	34154	Guard, Bumper, with Labels	23	16003	Pin, Hair, 1/2" To 9/16", .12" Wire
8	34148	Label, Danger, Keep Back	24	21155	Pin, Snap Safety, 3/8" X 2.75"
9	34162	Label, Impact Zone	25	33348	Bolt, Hex, Flange, 3/8-16 X 2.5"
10	33770	Caster, Yoke	26	33333	Nut, Nylon Lock, Flanged, 3/8-16
11	33763	Swivel Frame	27	21154	Pin, Clevis, 1/2" OD X 3.5" LG
12	27933	Bracket, Hitch Adjustment	28	18967	Washer, Flat, Neoprene, .490" ID X 1.06" OD X .09" TH
13	25489	Hitch Assembly	29	12685	Pin, Cotter, 3/16" X 1.5"
14	34161	Wheel, 9 X 3.50-4, Tracking	30	34147	Spring, 1" Diam X 9"L X .095" TH
15	25518	Wheel, Caster, 6" OD, 5/8" Bore			
16	10189	Grease Fitting, 1/4-28, Straight			

Schematic – Frame and Tow-Bar Assembly

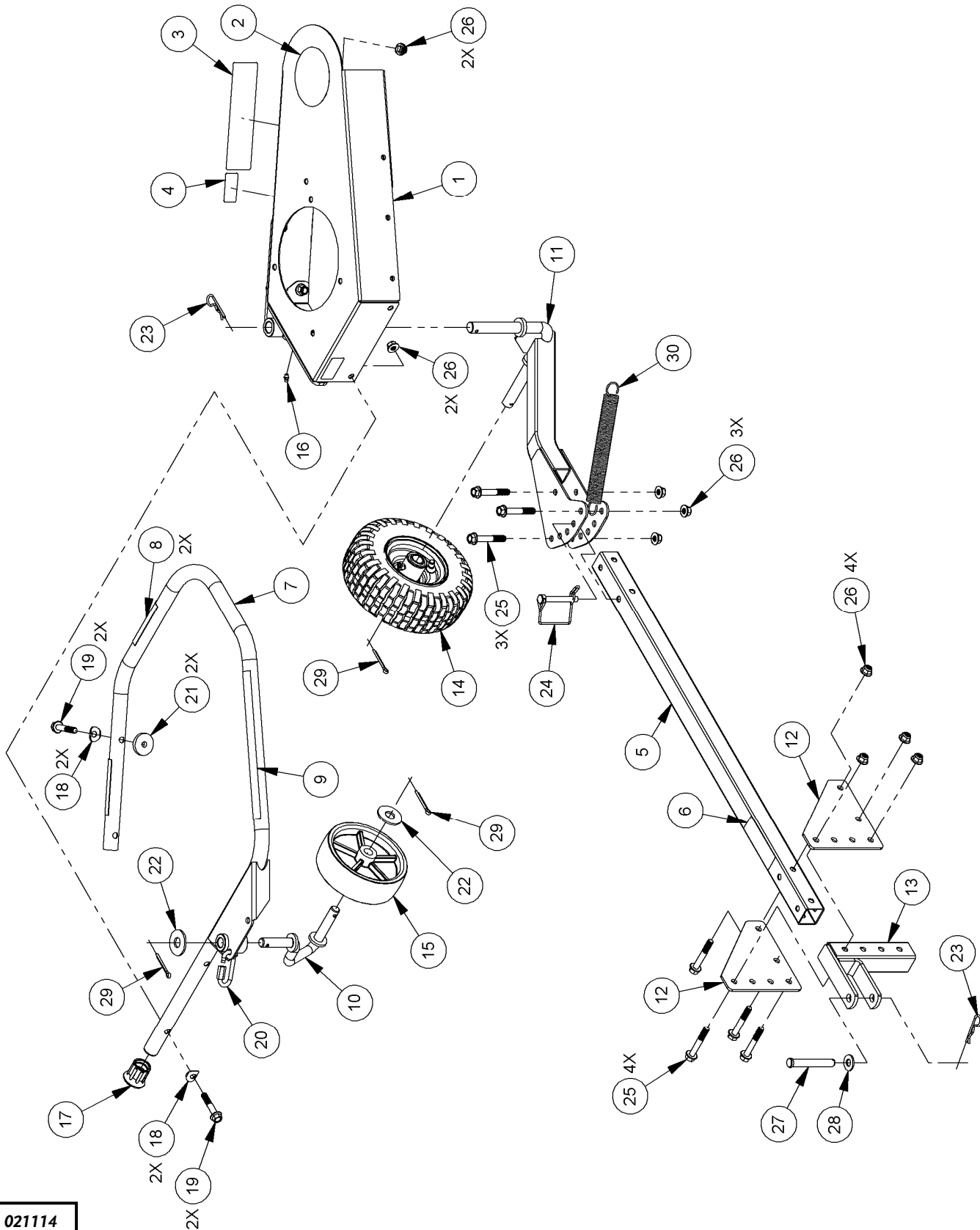

021114

Daily Checklist for the DR 6.25 TOW-BEHIND TRIMMER/MOWER

To help maintain your DR 6.25 TOW-BEHIND TRIMMER/MOWER for optimum performance, we recommend you follow this checklist each time you use your machine.

WARNING

Shut off the Tow Vehicle, set the parking brake and remove the Key. Shut off the Trimmer Engine and after all moving parts to come to a complete stop, wait five minutes for the machine to cool and disconnect the spark plug wire, keeping it away from the spark plug before performing any maintenance procedure or inspection on the Trimmer.

- [] OIL: With the machine on a level surface, check the Engine oil level with the Dipstick and add more if necessary (only add oil to the level indicated on the Dipstick - do not overfill). Use SAE 30 high detergent motor oil.
- [] GAS: Fill the Fuel Tank with clean, fresh, unleaded gasoline.
- [] ENGINE AIR COOLING SYSTEM: It is very important to keep the Engine clean of debris. Remove grass and other built-up materials from the Air Intake Screen before, during, and after you mow. Regularly remove debris from the Blower Housing and Cooling Fins. A dirty Engine retains heat and can cause damage to the internal Engine parts.
- [] CUTTING CORDS: Replace broken, frayed or missing Cords.
- [] GENERAL CONDITION: Check the general condition of the machine, e.g.; nuts, bolts, welds etc.
- [] MOW-BALL® and Line Plates: Check the Mow-Ball® and Line Plates for wear or damage and replace as needed.
- [] TIRE AIR PRESSURE: Check the air pressure in the Tires and adjust as needed.

End of Season and Storage

WARNING

Shut off the Tow Vehicle, set the parking brake and remove the Key. Shut off the Trimmer Engine and after all moving parts to come to a complete stop, wait five minutes for the machine to cool and disconnect the spark plug wire, keeping it away from the spark plug before performing any maintenance procedure or inspection on the Trimmer.

- Change the Engine oil. This will help to eliminate sludge and acids in the Engine.
- Lubricate Swivel Frame and Tracking Wheel Grease Fittings.
- Check the Drive Belt for wear. Replace as needed.
- Release Drive Belt from Tensioner to relieve Belt stress.
- Check the general condition of the machine, e.g.; nuts, bolts, welds, etc. Replace parts or tighten Hardware as needed.
- Store in a dry covered area to protect from moisture.
- Remove any wrapped weeds from the Trimmer Head and Wheel Assemblies. Clean grass and debris from the top and underneath the Trimmer Frame.
- Remove the Spark Plug and pour about 1 ounce of motor oil into the cylinder hole. Reinstall the Plug and pull the Recoil Starter Rope until you feel strong resistance. This will coat the piston and seat the valves to prevent moisture buildup.
- Clean or replace the Engine Air Filter.
- Clean any dirt and debris from the cylinder head cooling fins, carburetor linkage, blower housing, debris screen, and muffler area of the Engine.
- If your DR TRIMMER/MOWER will be idle for more than 30 days, we recommend using a gas stabilizer. This will prevent sediment from gumming up the Carburetor. If there is dirt or moisture in the gas or Tank, remove it by draining the Tank. Completely fill the Tank with fresh, unleaded gas and add the appropriate amount of stabilizer or gasoline additive. Run the Engine for a short time to allow the additive to circulate.



75 MEIGS ROAD, P.O. BOX 25, VERGENNES, VERMONT 05491