

TOW-BEHIND DR[®] FIELD and FINISH MOWER

SAFETY & OPERATING INSTRUCTIONS



Models: Mow Pro-44
Mow Pro-60



Serial No. _____

Order No. _____

DR Power Equipment
Toll-free phone: 1-800-DR-OWNER (376-9637)
Fax: 1-802-877-1213
Website: www.DRpower.com

WARNING

Read and understand this manual and all instructions before operating the TOW BEHIND DR FINISH MOWER.

Table of Contents

Chapter 1: General Safety Rules.....	5
Chapter 2: Setting up The TOW-BEHIND DR FIELD and FINISH MOWER	8
Chapter 3: Operating the TOW-BEHIND DR FIELD and FINISH MOWER.....	16
Chapter 4: Maintaining the TOW-BEHIND DR FIELD and FINISH MOWER	21
Chapter 5: Troubleshooting	28
Chapter 6: Parts Lists and Schematic Diagrams.....	30

Conventions used in this manual

⚠ WARNING

This indicates a hazardous situation, which, if not avoided, **could** result in death or serious injury.

⚠ CAUTION

This indicates a hazardous situation, which, if not avoided, **could** result in minor or moderate injury.

NOTICE

This information is important in the proper use of your machine. Failure to follow this instruction could result in damage to your machine or property.

Serial Number and Order Number

A Serial Number is used to identify your machine and is located on the Serial Number Label on your machine (**Figure 1**). An Order Number is used to check and maintain your order history and is located on the upper left portion of your packing slip. For your convenience and ready reference, enter the Serial Number and Order Number in the space provided on the front cover of this manual.

Additional Information and Potential Changes

DR Power Equipment reserves the right to discontinue, change, and improve its products at any time without notice or obligation to the purchaser. The descriptions and specifications contained in this manual were in effect at printing. Equipment described within this manual may be optional. Some illustrations may not be applicable to your machine.

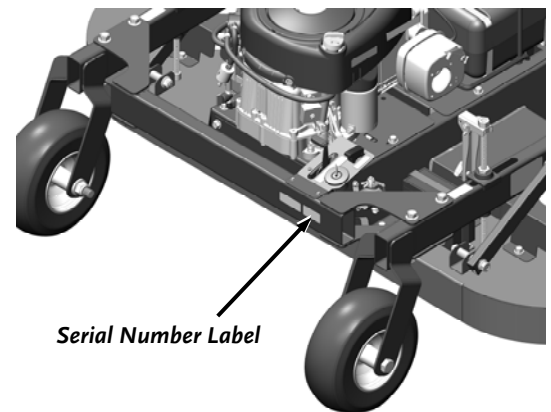

Figure 1

Chapter 1: General Safety Rules

WARNING

Read this Safety & Operating Instructions manual before you use the TOW BEHIND DR FINISH MOWER. Become familiar with the operation and service recommendations to ensure the best performance from your machine. If you have any questions or need assistance, please contact us at www.DRpower.com or call toll-free 1-800-DR-OWNER (376-9637) and one of our Technical Support Representatives will be happy to help you.

Labels

Your TOW-BEHIND DR FIELD and FINISH MOWER carries prominent labels as reminders for its proper and safe use. Shown below are copies of all the Safety and Information labels that appear on the equipment. Take a moment to study them and make a note of their location on your Mower as you set up and before you operate the unit. Replace damaged or missing safety and information labels immediately.



#13649



#13683

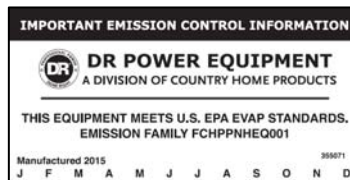

#35507



#13758



37349



#37350



#37125

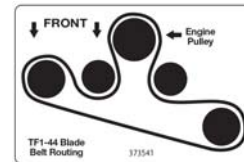

37354

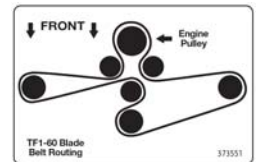

37355



#36585



#37122



#36584

Protecting Yourself and Those around You

WARNING

This is a high-powered machine with moving parts operating at high speeds. Always take the following precautions when operating this machine:

- Always wear protective goggles or safety glasses with side shields.
 - We recommend wearing sturdy shoes with non-slip tread, long pants, and gloves while using this machine. Be sure the gloves fit properly and do not have loose cuffs or drawstrings.
 - Use ear protectors or ear plugs.
 - Allow only responsible adults who are familiar with these safety rules and operating instructions to use your DR FINISH MOWER.
 - Keep your hands and feet away from the blades, belt, pulley, and concealed areas while the engine is running.
 - Keep people and pets away from your machine and out of the work area at all times. Disengage the blade and stop the engine if a person or pet is within 100 feet of the machine.
 - Children are often attracted to the machine and the mowing activity. Never assume that children will remain where you last saw them.
 - Never allow people to ride on the mower.
 - Before mowing, clear the area of objects such as rocks, toys, wire, bones, sticks, etc.
 - Never remove or alter standard parts or add anything to the DR FINISH MOWER, especially all shields and guards.
 - Before and while moving backwards, look behind, and down for small children.
 - Use extra care when approaching blind corners, shrubs, trees, or other objects that may obscure your vision.
-

Safety with Gasoline - Powered Machines

WARNING

Gasoline is a highly flammable liquid that gives off flammable vapor that can be ignited and cause a fire or explosion. Always follow these precautions:

- Never run the engine in an enclosed area or without proper ventilation as the exhaust contains carbon monoxide, an odorless, tasteless, and poisonous gas.
 - Store all fuel and oil in containers specifically designed and approved for this purpose. Keep away from heat and open flame and out of the reach of children.
 - Replace rubber fuel lines and grommets when worn or damaged or after 5 years of use, whichever comes first.
 - Fill the gasoline tank outdoors with the engine off and after the engine has cooled completely. Don't handle gasoline if you or anyone nearby is smoking.
 - If you spill gasoline do not start the engine. Move the machine away from the area until the gas vapors have dissipated.
 - Before performing engine maintenance or repairs, shut down the engine, disconnect the spark plug wire, and wait 5 minutes for the engine to cool.
 - Never change the engine governor settings or modify the engine speed.
 - Never check for an ignition spark with the spark plug or spark plug wire(s) removed. Always use an approved spark tester.
 - Never tamper with safety devices. Regularly check their proper operation.
 - Allow the engine to cool completely before storing in any enclosed area.
 - Keep combustible substances away from the engine when it is hot. Never cover the machine while the muffler is still hot.
 - To reduce fire hazard, keep the engine and muffler free of debris build-up.
 - Do not operate the engine with the air cleaner or the carburetor air intake cover removed.
 - Do not use flammable solutions to clean the air filter.
 - Never operate the engine without the muffler and deflector, if so equipped. Inspect the muffler and deflector periodically and replace if necessary.
 - The muffler and engine become very hot and can cause a severe burn. Do not touch.
-

Slope Operation

WARNING

Use of machinery on slopes is a major factor in outdoor power equipment accidents. All slopes require caution. If you feel uneasy on a slope, do not mow it. Always take the following precautions when using this machine on slopes:

- Operate the machine up and down the face of slopes. Exercise extreme caution when changing direction on slopes.
- Never operate near drop-offs, ditches, or embankments or on slopes greater than 20 degrees.
- Never operate on wet or slippery slopes.
- Never park the tow vehicle on a steep grade or slope.

General Safety

WARNING

Safe operation of the TOW-BEHIND DR FINISH MOWER is necessary to prevent death or serious injury. Always take the following precautions when operating this machine:

- The TOW-BEHIND DR FINISH MOWER is designed to mow grass. Do not use it for any other purpose.
- If the machine makes an unusual noise or vibration or if there are obstructions underneath the machine, shut off the tow vehicle and the DR FINISH MOWER engines. Wait five minutes for the engine to cool. Disconnect the spark plug wire and then inspect the machine for clogs or loose parts. Clear any obstructions and repair and/or replace damaged parts.
- The mower blades are sharp. Wrap the blades or wear gloves and use extra caution when servicing.
- Always keep the machine in good, safe operating condition. Always make certain nuts and bolts are tight. Do not use substitute hardware.
- Use the TOW-BEHIND DR FINISH MOWER only in daylight.
- Always give undivided attention to the machine and your surroundings. Watch for traffic when mowing near roadways.
- Disengage the mower blades and exercise extreme caution when on or crossing drives, walks, or roads.
- If leaving the machine, shift the tow vehicle into neutral and set the parking brake; turn off the tow vehicle engine and remove its key. Turn off the DR FINISH MOWER engine and remove its key.
- Do not operate the mower when under the influence of alcohol, drugs, or medication.
- Do not operate the mower when there is a risk for lightening.

California Proposition 65

WARNING

California Proposition 65:

- Engine exhaust and some of its constituents are known to the State of California to cause cancer, birth defects, and other reproductive harm.
- This product contains or emits chemicals known to the State of California to cause cancer, birth defects, and other reproductive harm.

A Note to All Users

Under California law, and the laws of some other states, you are not permitted to operate an internal combustion engine using hydrocarbon fuels without an engine spark arrester. This also applies to operation on US Forest Lands. All TOW-BEHIND DR FIELD and FINISH MOWERS shipped to California, New Mexico and Washington State are provided with spark arresters. Failure of the owner or operator to maintain this equipment in compliance with state regulations is a misdemeanor under California law and may be in violation of other state and/or federal regulations. Contact your State Park Association or the appropriate state organization for specific information in your area.

No list of warnings and cautions can be all-inclusive. If situations occur that are not covered by this manual, the operator must apply common sense and operate this TOW-BEHIND DR FIELD and FINISH MOWER in a safe manner. Contact us at www.DRpower.com or call 1-800-DR-OWNER (376-9637) for assistance.

Chapter 2: Setting up The TOW-BEHIND DR FIELD and FINISH MOWER

It may be helpful to familiarize yourself with the controls and features of your TOW-BEHIND DR FIELD and FINISH MOWER by reviewing **Figure 2** before beginning these procedures. If you have any questions at all, please feel free to contact us at www.DRpower.com.

TOW-BEHIND DR FIELD and FINISH MOWER Controls and Features (Mow Pro-44 Model)

Note: The model shown in Figure 1 may look slightly different from your machine.

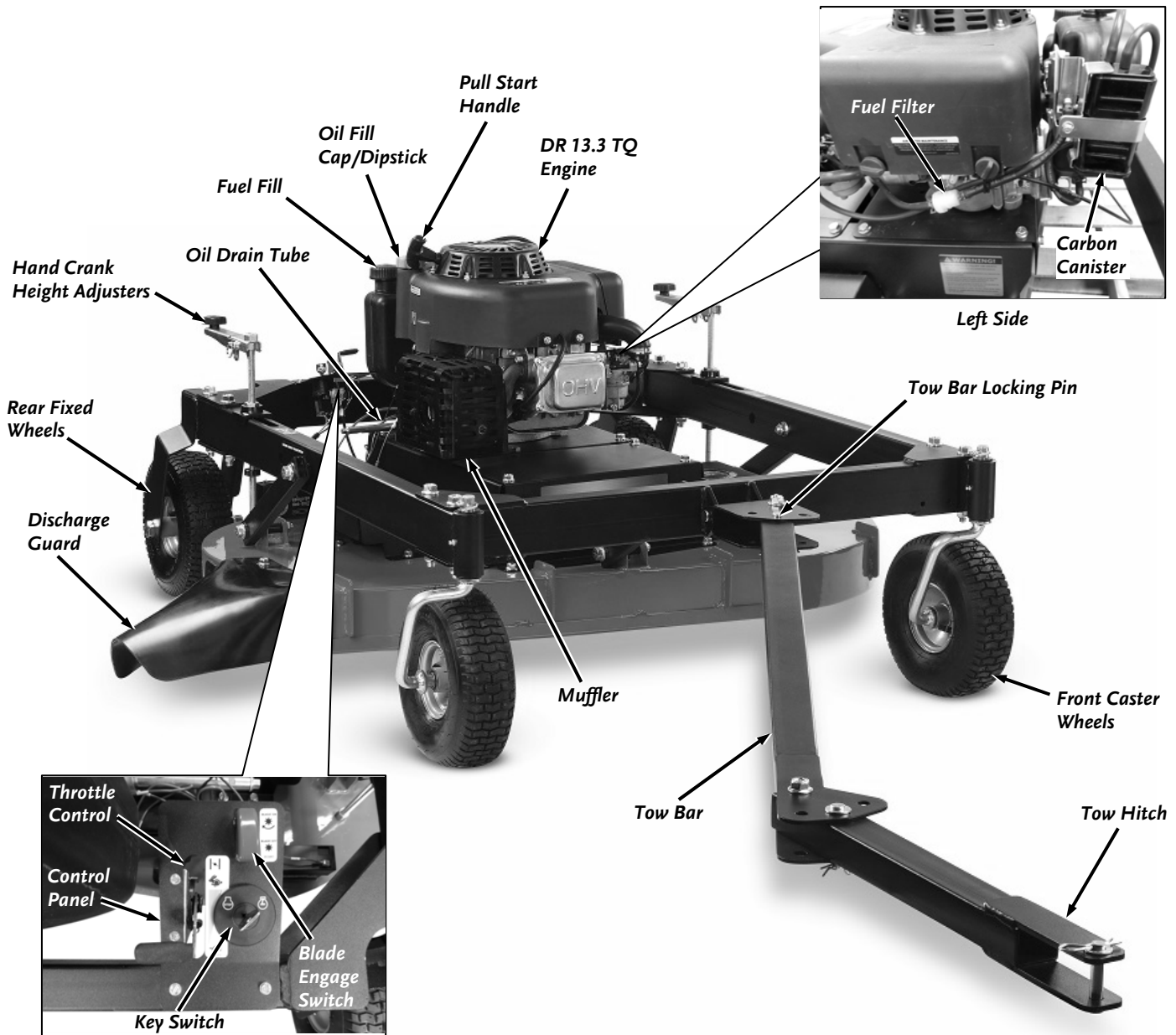

Figure 2

TOW-BEHIND DR FIELD and FINISH MOWER Controls and Features (Mow Pro-60 Model)

Note: The model shown in Figure 1 may look slightly different from your machine.

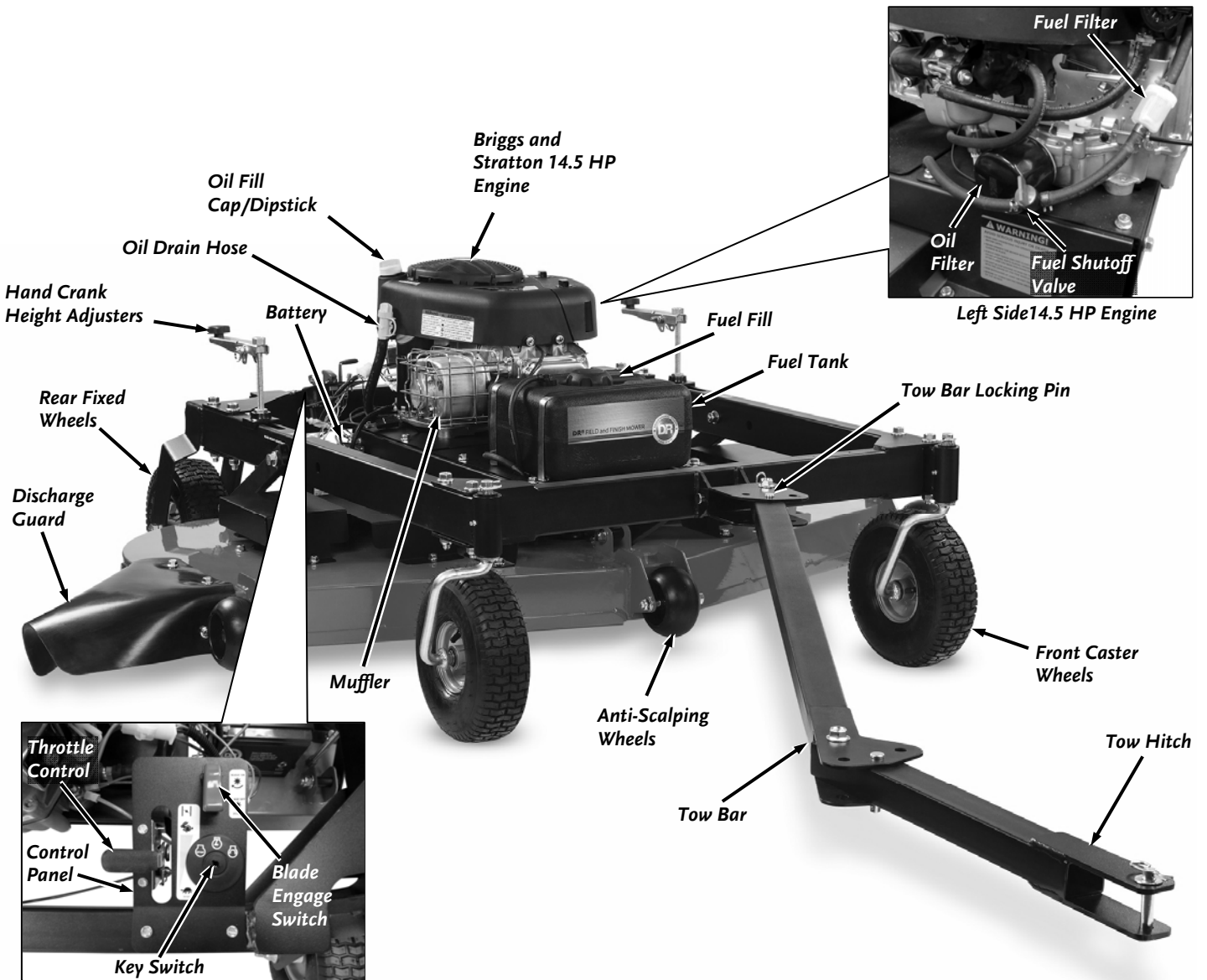

Figure 3

Specifications

	13.3 TQ Mow Pro-44 Model	14.5 HP Mow Pro-60 Model
Engine	See your Engine Manual for oil capacity and other Engine specifications.	See your Engine Manual for oil capacity and other Engine specifications.
Starting System	Manual Start	Electric Start
Fuel Tank	3.5 L (.92 gal), Gasoline, Unleaded	2.5 Gal. (9.46 L), Gasoline, Unleaded
Battery	NA	12V, 9Ah
Wheels	Front: 11 X 4 Turf Tread Rear: 11 X 4 Turf Tread	Front: 11 X 4 Turf Tread Rear: 11 X 4 Turf Tread
Distance From Centerline of Tow Vehicle to Outer Cutting Edge	Straight Back: 22" Offset Position 1 (either L or R): 49.5" Offset Position 2 (either L or R): 68"	Straight Back: 30" Offset Position 1 (either L or R): 57.5" Offset Position 2 (either L or R): 76"
Number of Offset Positions	5	5
Adjustable Cutting Height	From 1-1/2" min. to 5-1/2" max.	From 1-1/2" min. to 5-1/2" max.
Cutting Width	44"	60"
Cutting Capacity	2' high grass	2' high grass
Blade Tip Speed	18,500 - 19,000 ft/min	17,500 - 18,000 ft/min
No. of Blades	2	3
Blades Type	Air Tipped	Air Tipped
Deck	12 GA Welded Steel	12 GA Welded Steel
Discharge	Side	Side
Spindle	1" Dia. Shaft with 2 Sealed 20 mm Bearings	1" Dia. Shaft with 2 Sealed 20 mm Bearings
Belt	A76	AK124
Electric Clutch	75 ft-lb	75 ft-lb
Max Speed Mow/Tow	5mph	5mph
Tongue Weight	10 lbs.	10 lbs.
Machine Dimensions	132" L x 60" W x 29" T	132" L x 75" W x 26" T
Machine Weight	270 lbs.	320 lbs.

Assembling the TOW-BEHIND DR FIELD and FINISH MOWER

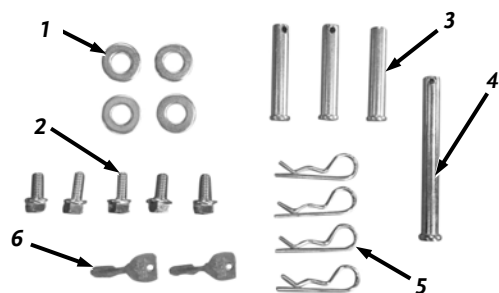

Figure 4

Hardware Supplied in Product Package (Figure 4 and Table below):

Item #	Part #	Description	Qty
1	23499	Washer, SAE Flat, 1/2", ZP	4
2	35281	Bolt, Hex, Flange, Tri Lobe, 3/8-16 X 3/4", GR5 ZP	5
3	25549	Pin, Clevis, 1/2" x 2 1/2", TRT	3
4	18737	Pin, Clevis, 1/2" OD X 4.5" LG	1
5	16003	Pin, Hair, 1/2" To 9/16", .12" Wire	4
6	15720	Key Ignition Switch	2

Compare the hardware of the Product Package with **Figure 4** and the "Hardware Supplied" list above. If you have any questions, please contact us at www.DRpower.com.

The Mow Pro-44 Model is shipped mostly assembled. Go to “Installing the Discharge Guard” section if you have a Mow Pro-44 Model.

Tools and Supplies Needed:

- Wire Cutters
- Two 3/4" Wrenches
- 7/8" Socket with Torque Wrench
- 1-1/16" Wrench*
- 5/16" Wrench
- Blocking

*or Adjustable Wrench

Assembling the Deck to the Frame (Mow Pro-60 Model only)

1. Leave the Deck Bushings in place as you remove the Bolt and Locknut (by hand) that secures the two side Sway Braces to the Deck (**Figure 5**).
2. Leave the Deck Bushing in place as you remove the Bolt and Locknut (by hand) that secures the front Sway Brace to the Deck (**Figure 6**).
3. Remove the remaining Bolts and Locknuts from the three Sway Braces.
4. Remove the three Nuts, Hand Crank and Height Adjust Block from both threaded Rods (**Figure 7**).
5. Position the two Threaded Rods so they are vertical.
6. Place the Frame Assembly as shown with the Caster Wheels next to the back of the Deck Assembly. Turn the Casters toward the rear wheels (**Figure 8**).
7. With the help of another person, position the Frame over the Deck Assembly with the Threaded Rods through the slots in the Frame (**Figure 9**).

Note: We recommend adding Blocking at both sides of the Pallet to help stabilize the Wheels (**Figure 10**).

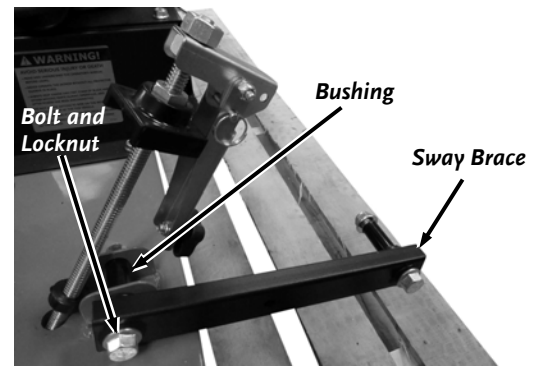

Figure 5

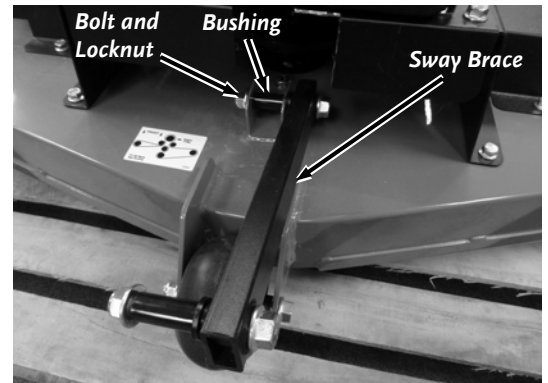

Figure 6

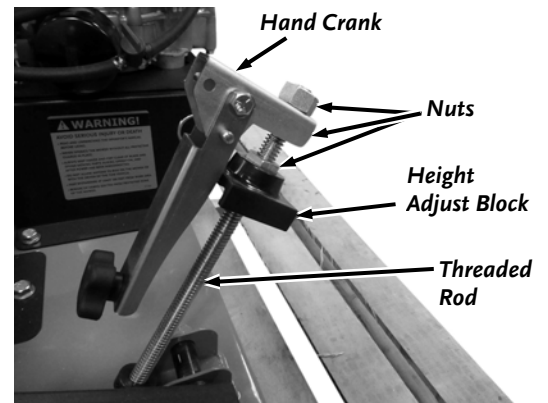

Figure 7

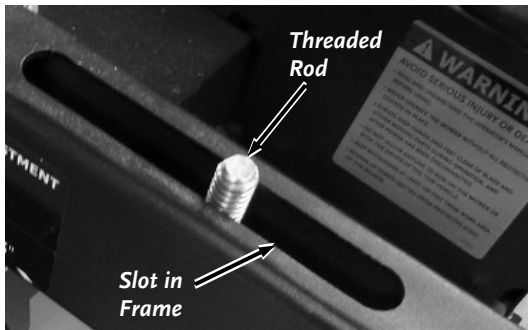

Figure 9

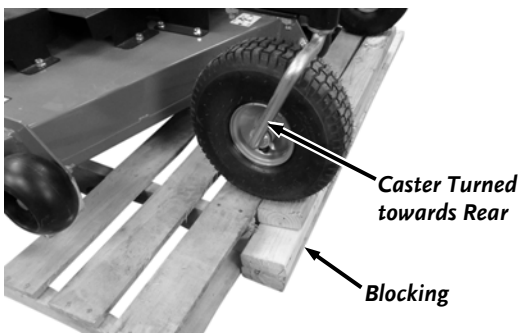

Figure 10

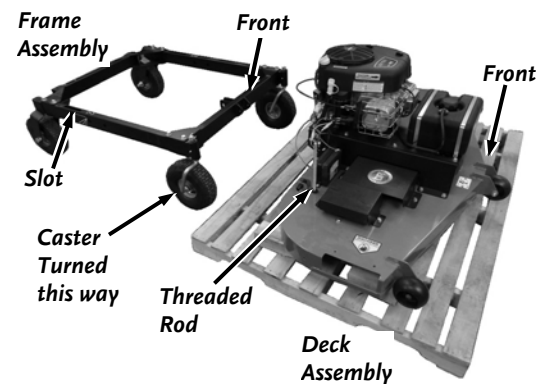

Figure 8

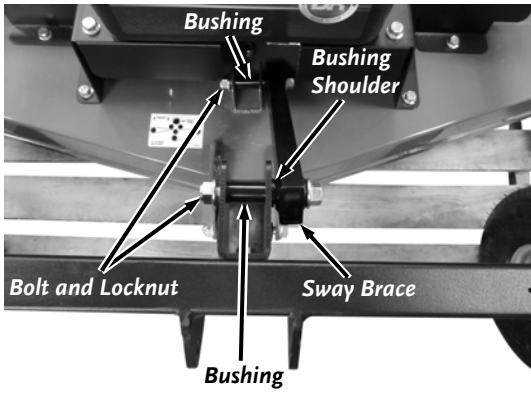

Figure 11

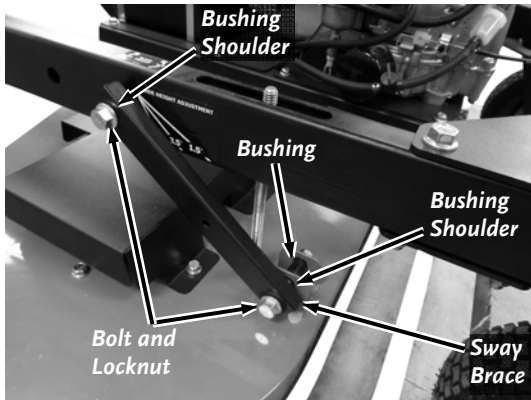

Figure 12

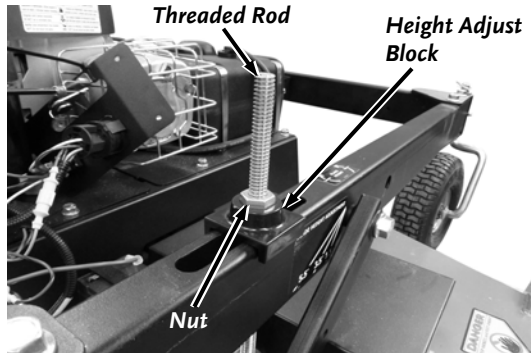

Figure 13

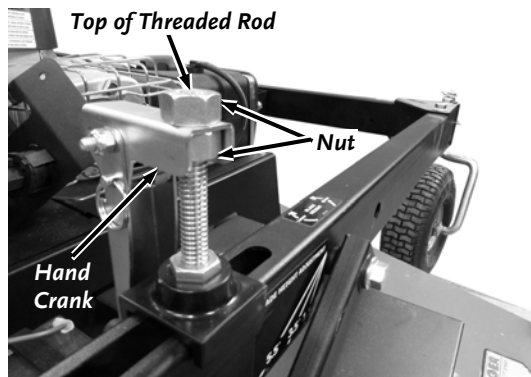

Figure 14

Note: The Bushings in the Deck Brackets should still be in place as instructed in earlier steps.

8. Install the Bushing into the Bracket at the front of the Frame with the long portion of the Bushing fully into the Frame Bracket (**Figure 11**). The Bushing shoulder should be tight against the Bracket.
9. Install and secure the front Sway Brace with the two Bolts and Locknuts using two 3/4" Wrenches.
10. Install the Bushings into the sides of the Frame with the long portion of the Bushing fully into the Frame Bracket (**Figure 12**). The Bushing shoulder should be tight against the Bracket.
11. Install and secure the two side Sway Braces with the Bolts and Locknuts using two 3/4" Wrenches.
12. Pull up on the Threaded Rod and install the Height Adjust Block as far as it will go followed by a Nut (**Figure 13**). When the Nut touches the Block, turn the Rod so the Nut can set inside the Block.
13. Install a Nut at the top of the Threaded Rod, followed by the Hand Crank and then another Nut (**Figure 14**).

Note: When tightened in the next step, the top nut must be flush with the end of the Threaded Rod.

14. Hold the Hand Crank with a 1-1/16" Wrench (or Adjustable Wrench) as you tighten the top Nut against the Hand Crank using a 7/8" Socket and Torque Wrench to 25-30 ft-lbs.
15. Cut the Cable Tie that is securing the Control Panel to the Muffler Guard using Wire Cutters (**Figure 15**).
16. Remove the Screws from the Frame using a 5/16" Wrench and install Control panel to the Frame (**Figure 16**).

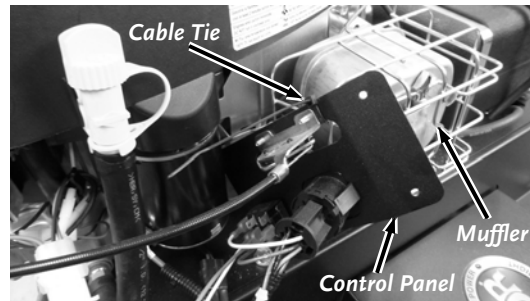

Figure 15

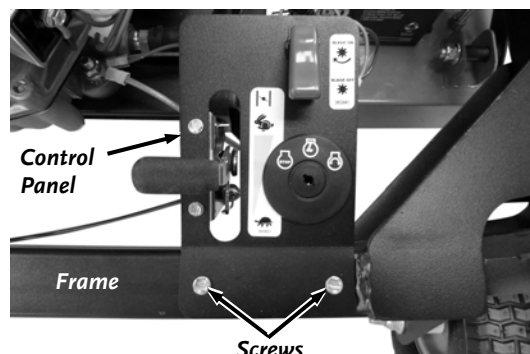

Figure 16

Installing the Discharge Guard

1. Install the Discharge Guard with five 3/8-16 X .75" Bolts using a 9/16" Wrench (**Figure 17**).

Note: If it is difficult to install the Bolt at the front (Mow Pro-60 Model) the Anti-scalping Wheel can be removed using a 9/16" Wrench and Adjustable Wrench to make it easier.

Attaching the Tow Bar to the Push Bar

The Tow Bar can be installed for offsetting to the right or left depending on which side of the Tow Vehicle you choose to mow. See section "Offset Mowing" in Chapter 3 to determine how the Tow Bar should be installed for your needs. The following steps describe positioning the Offset Bracket to allow offset to the right side of the Tow Vehicle.

1. Secure the Offset Bracket to the Push Bar in the configuration shown (for right side offset) using the 4.5" long Clevis Pin, Washer, and Hair Pin (**Figure 18**).
2. Align the Tow Bar so it is pointed straight out from the Mower and install a Clevis Pin, Washer, and Hair Pin in the Offset Bracket to lock the Tow Bar in position.

WARNING

Always install the Clevis Pins from the bottom with the Washers and Hair Pins on top to prevent the Hair Pin from being pulled out by tall grass or bushes.

3. Align the Tow Bar Extension with the Tow Bar and install a Clevis Pin, Washer, and Hair Pin in the Tow Bar to lock the Tow Bar Extension in place (**Figure 19**).
4. Raise the Deck (see "Adjusting the Mower Deck Height" in Chapter 3) and with a helper, roll machine backwards off Pallet. You May need to use a bar to lift deck over the Blocks if it gets hung up.

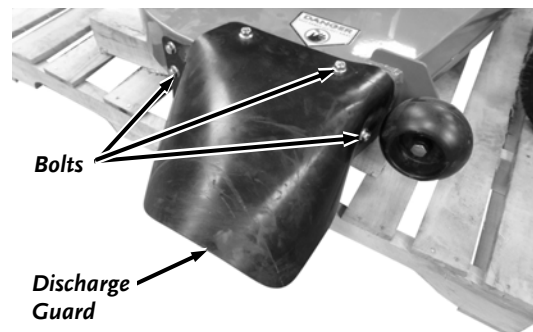

Figure 17

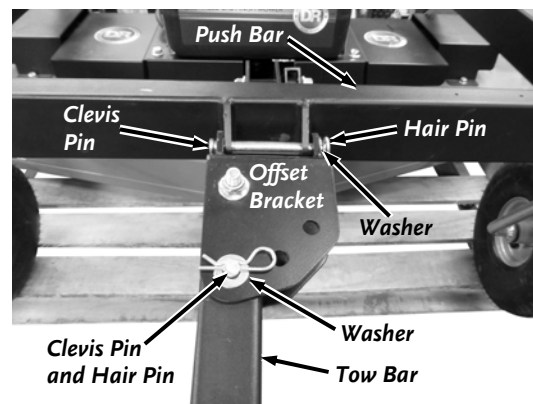

Figure 18

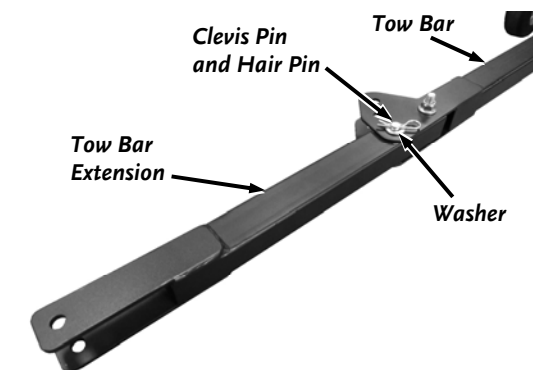

Figure 19

Adding Oil and Gasoline

Tip: To avoid confusion, we recommend leaving the caps on the Fuel and Oil Fills until you are ready to pour either gasoline or oil into the correct Fill.

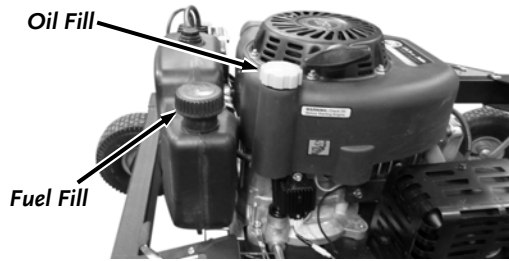

Figure 20a: DR 13.3 TQ Engine

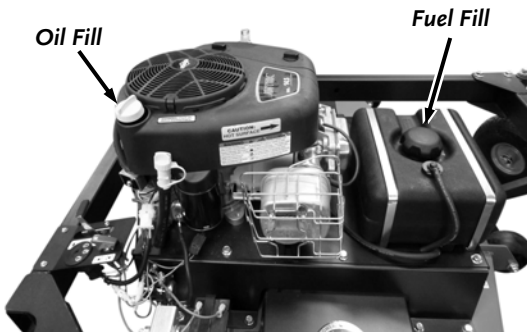

Figure 20b: Briggs and Stratton 14.5 HP Engine

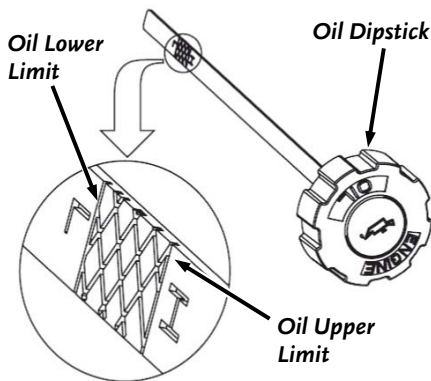

Figure 21

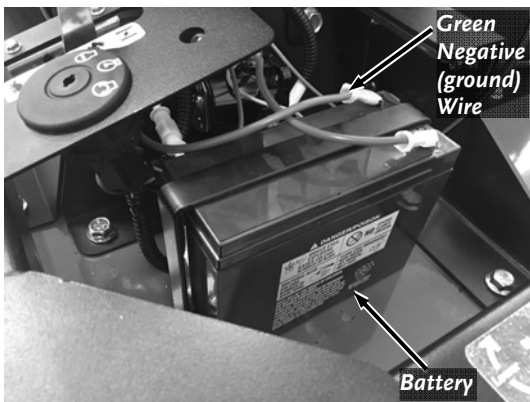

Figure 22

Engine Oil and Fuel Capacities		
	Oil (SAE 30 HD)	Fuel (Unleaded)
DR – 13.3 TQ	37 oz (1.1 L)	0.92 gal (3.5 L)
Briggs and Stratton – 14.5 HP	48 oz. w/Filter	2.5 Gal (9.46 L)

Note: Use only SAE 30 HD (High Detergent) oil. Other types of oil could cause problems with the operation of your machine.

Please refer to your Engine Owner's Manual for detailed information for Oil and Fuel procedures.

NOTICE

- You must add oil before starting the engine. This machine is shipped without oil. Traces of oil may be in the reservoir from factory testing, but **YOU MUST ADD OIL BEFORE STARTING THE ENGINE**. Fill the reservoir slowly, checking the level frequently to avoid overfilling.
- To get an accurate reading when checking the oil level:
 - The machine should be on a level surface.
 - 13.3 TQ Engine: The dipstick **SHOULD NOT** be screwed down.
 - 14.5 HP Engine: The dipstick **SHOULD** be screwed down.

- Place the machine on a level surface and remove the Oil Fill Cap/Dipstick (**Figure 20a: Mow Pro-44**) (**20b: Mow Pro-60**).
- Initially add 32 oz. of SAE 30 High Detergent oil (recommended by the Engine Manufacturer) into the Oil Fill and wait one minute for the oil to settle.
- 13.3 TQ Engine:** Replace the Dipstick but **DO NOT** screw on, and then remove it to check the oil level (**Figure 21**). Continue adding a few ounces of oil at a time, rechecking the Dipstick until the oil reaches the fill mark. Be careful not to overfill.
- 14.5 HP Engine:** Replace the Dipstick and screw on fully, and then remove it to check the oil level (**Figure 21**). Continue adding a few ounces of oil at a time, rechecking the Dipstick until the oil reaches the fill mark. Be careful not to overfill.
- Remove the Fuel Cap and fill the gas tank to within 1-1/2" below top of fill neck (to allow for fuel expansion) with fresh, unleaded gas (**Figure 20a: Mow Pro-44**) (**20b: Mow Pro-60**). Replace the Fuel Cap when finished.

Connecting the Battery Wire (Electric Start Model only)

We ship all Electric-Starting machines with the green negative (ground) Battery Wire disconnected. This prevents the Battery from discharging during shipment. Before using your TOW-BEHIND DR FIELD and FINISH MOWER, you must connect the green negative Battery Wire.

- Push the negative Wire Connector fully onto the negative terminal of the Battery (**Figure 22**).

Connecting the TOW-BEHIND DR FIELD and FINISH MOWER to your Tow Vehicle

The Pin type Hitch that comes standard on the TOW-BEHIND DR FIELD and FINISH MOWER Tow Bar is quick and easy to attach to Tow Vehicles with a hole in the Hitch Plate. A ball Hitch Kit is also available if you would prefer attachment to a 2" Ball on the Tow vehicle. Visit our website at www.DRpower.com to order Ball Hitch Kit #36578.

1. Move your Tow Vehicle to a flat area and set the Parking Brake.
2. Align the Tow Hitch to the tow vehicle Hitch Plate with the top portion of the Tow Hitch above the Hitch Plate and the bottom portion below (**Figure 23**).
3. Secure the Hitch with the Clevis Pin and Hair Pin.

Checking the Tire Pressure

Tools Needed:

- Tire Pressure Gauge
- Air Compressor

1. Remove the Valve Stem Protective Cap (**Figure 24**) and check the tire pressure with a Tire Pressure Gauge.

Note: *Figure 24 shows the fixed rear Wheels. Use the same procedure for the front Caster Wheels.*

2. Compare the tire pressure reading from with the manufacturer's recommended tire pressure stamped on the side of the tire.
3. If the pressure is too low, add air through the Valve Stem with an air hose.
4. Replace the Valve Stem Protective Cap when finished.

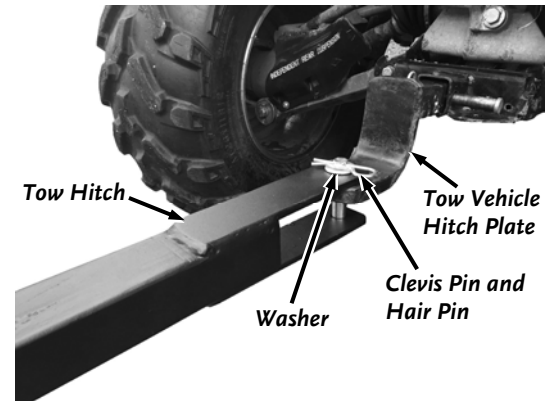

Figure 23

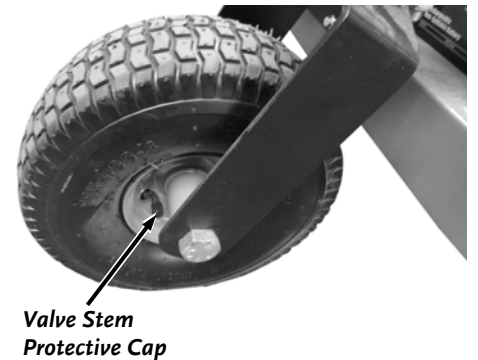

Figure 24

WARNING

Do not over inflate the tires. Inflate to the manufacturers recommended pressure found on the tires.

Chapter 3: Operating the TOW-BEHIND DR FIELD and FINISH MOWER

This chapter covers the procedures for starting and stopping your new TOW-BEHIND DR FIELD and FINISH MOWER and discusses basic operation features. You may find it helpful to review the TOW-BEHIND DR FIELD and FINISH MOWER Controls and Features in Chapter 2 before reading this chapter.

! WARNING

- This machine is designed for cutting grass. Never use this machine for any other purpose as it could cause serious injury.
- Contact with internal rotating parts will cause serious personal injury. Never put hands, face, feet, or clothing under the deck or near the discharge area with the engine running.
- Before performing any maintenance procedure or inspection, stop the engine and wait five minutes to allow all parts to stop and cool. Disconnect the spark plug wire, keeping it away from the spark plug.

Operating Parameters

We recommend a few types of Tow Vehicles for the TOW-BEHIND DR FIELD and FINISH MOWER. The Tow Vehicle may be either 2 or 4 wheel drive. See the Tow Vehicle Restrictions section below.

- ATV
- Lawn/Garden Tractor (17 HP and above and weighing at least 500 pounds)
- Riding Lawn Mower (14 HP and above and weighing at least 400 pounds)
- Utility Vehicle
- Compact or Sub-Compact Tractor

Tow Vehicle Restrictions:

- Riding Lawn Mowers with Engines under 17 HP and weighing less than 500 pounds are not suitable for use on slopes greater than 5°.
- Never operate your TOW-BEHIND DR FIELD and FINISH MOWER on slopes greater than 20° using any type of Tow Vehicle.

! CAUTION

- We do not recommend driving over 5 mph While towing or operating your TOW-BEHIND DR FIELD and FINISH MOWER.
- Never use a truck (2 or 4wd) or jeep to operate the TOW-BEHIND DR FIELD and FINISH MOWER. It would be difficult to see the Mower. Using these vehicles will void the TOW-BEHIND DR FIELD and FINISH MOWER warranty.

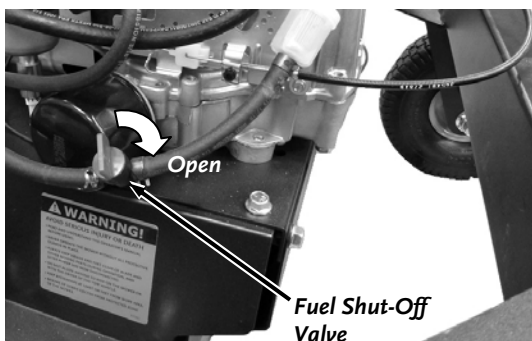

Figure 25: Mow Pro 60

Before Starting the Engine

! WARNING



Inspect the area where you will be working. The site must be free of potentially hazardous obstacles such as glass, large stones, sticks, wire, rope, and string-like materials. Make sure there are no people or animals in the area around the TOW-BEHIND DR FIELD and FINISH MOWER.

1. Check the oil level every time you use the machine. See your Engine Owner's Manual.
2. Check the gasoline level.
3. Open the Fuel Shut-Off Valve (Mow Pro-60) on the left hand side of the Mower (**Figure 25**).

4. Make sure the Blade Switch Safety Cover is pushed down to the disengaged position (**Figure 26**).

Note: The Blade Switch Safety Cover must be pushed down or the Engine will not start.

Starting (Mow Pro-44 Model)

1. Ensure the Blade Switch Safety Cover is down (**Figure 26**).
2. When starting a cold Engine, push the Throttle Control Lever up to the Choke  position (**Figure 15**). When starting an already warm Engine, push the Throttle Control Lever to the Run  position.

3. Turn the Key Switch to the run  position.

4. Grasp the Recoil Starter Handle and slowly pull until you feel resistance (**Figure 27**). Let the Cord retract a little bit, and then pull the Cord rapidly to start the Engine.

Note: One or two pulls usually starts the Mower, but more pulls may be necessary if the Tank was completely empty before filling.

5. As the Engine warms up, slowly adjust the Throttle to the Run  position. Wait until the Engine runs smoothly before each Throttle adjustment. For maximum performance, operate the Engine with the Throttle in the Run position.

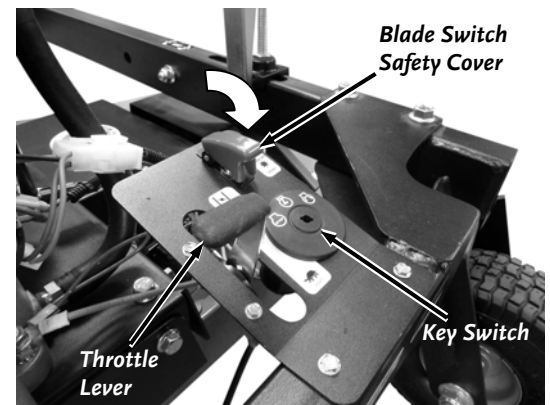

Figure 26

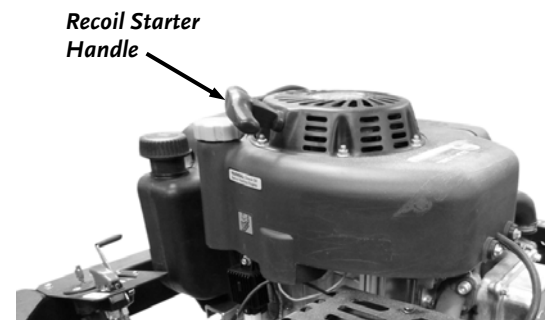





Figure 27

Starting (Mow Pro-60 Model)



1. Ensure the Blade Switch Safety Cover is down (**Figure 26**).

2. When starting a cold Engine, push the Throttle Control Lever up to the Choke  position (**Figure 26**). When starting an already warm Engine, push the Throttle Control Lever to the Run  position.

3. Turn the Key Switch to the Start  position until the Engine starts, then release. The Key will snap back to the center Run  position and the Engine will continue to run.

4. As the Engine warms up, slowly adjust the Throttle to the Run  position. Wait until the Engine runs smoothly before each Throttle adjustment. For maximum performance, operate the Engine with the Throttle in the Run position.

Stopping the Engine

1. Disengage the Blades by pushing the Blade Control Safety Cover down (**Figure 25**).
2. Move the Throttle Control Lever all the way down to the Idle  position and turn the Key to Stop  (**Figure 26**).
3. Remove the Key for safety.

Note: Close the Fuel Shut-Off Valve when transporting or storing the TOW-BEHIND DR FIELD and FINISH MOWER (**Figure 24**).

NOTICE

Never stop the engine by moving the throttle control lever to the choke position. This could cause an engine backfire resulting in engine damage.

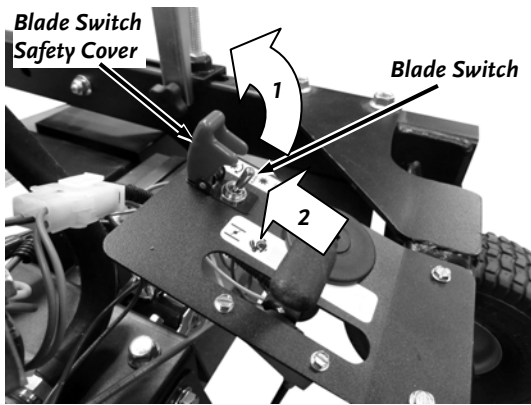

Figure 28

Engaging the Blades

1. Engage the Blades by pulling up on the Blade Switch Safety Cover and pushing forward on the Blade Control Switch (**Figure 28**).

Stopping the Blades

1. Push down on the Blade Control Safety Cover (**Figure 26**).

Adjusting the Mower Deck Height

! WARNING

- Shut off the engine before adjusting the deck height or serious injury may result. The blades could sever your foot if it goes under the deck with the engine running.
- Never get off the Tow Vehicle without shutting off the Tow Vehicle engine and engaging the parking brake.

! CAUTION

Keep your foot clear of the mower deck when adjusting the height. You could pinch your foot if it is under the deck.

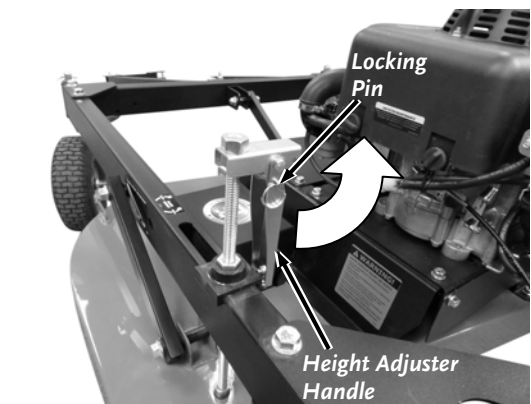

Figure 29

Note: The TOW-BEHIND DR FIELD and FINISH MOWER Deck cutting Height ranges from a minimum of 1-1/2" to a maximum of 5-1/2".

1. Remove the Locking Pin from the Height Adjuster (**Figure 29**).
2. Lift the Handle up to the operating position and re-install the Locking Pin (**Figure 30**).
3. Repeat Steps 1 and 2 for the Height Adjuster on the opposite side.

Note: Rotating the Height Adjusters Clockwise will lower the Mower Deck. Rotating the Height Adjusters Counter Clockwise will raise the Mower Deck. Ten full rotations equal 1" of height change.

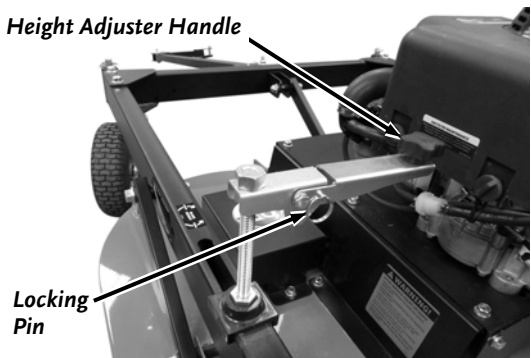

Figure 30

4. Rotate both Height Adjusters in the desired direction, switching sides about every ten full turns, until the top of the Sway Brace is aligned with the desired cutting height lines on the Height Adjust label. (**Figure 31**).
5. After the height is set the same on both sides of the machine, rotate the Handle to the inside of the Frame, pull the Locking Pin, fold the Handle down and insert the Locking Pin to secure the Handle in the down position.

NOTICE

The Height Adjust Handle should always be pinned on the inside of the Frame and in the down position for mowing. This prevents the Height Adjuster from rotating and lowering the Deck during use.

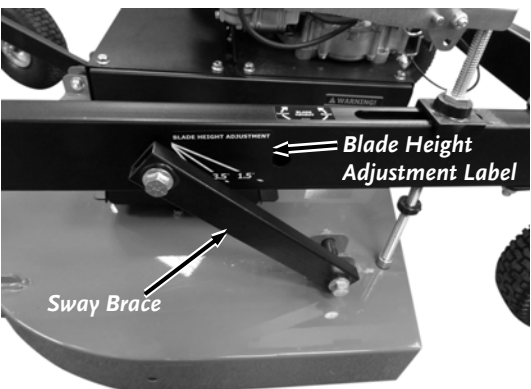

Figure 31

Offset Mowing

The Tow Bar allows you to offset the cutting path of the TOW-BEHIND DR FIELD and FINISH MOWER up to 68" (Mow Pro-44 Model) and 76" (Mow Pro-60 Model) from the center of the Tow Vehicle. The various offset positions are listed in the "Specifications" section in Chapter 2. Offset mowing allows you to mow closer to equipment, trees, and fences while the Tow Vehicle stays at a safer distance. It also allows you to drive in an area already cut and not through grass that hasn't been cut yet.

See the section "Changing the Tow Bar Offset Direction" on the next page to allow offsetting the Mower to the left side of the Tow Vehicle.

⚠ CAUTION

When performing offset mowing, always be sure that the Tow Bar offset and the Tow Bar Extension offset match (**Figure 32**). This ensures the Tow-Behind DR Field and Finish Mower will track parallel to the tow vehicle path.

Offsetting the Tow Bar:

1. Remove the Hair Pin, Washer, and Clevis Pin that secures the Tow Bar in the Offset Bracket (**Figure 33**).
2. Rotate the Tow bar to the Desired Offset (No Offset, Middle Offset, or Full Offset).
3. Reinstall the Clevis Pin, Washer, and Hair Pin to Lock the Tow Bar in Place.

⚠ WARNING

Always install the Clevis Pins from the bottom with the Washers and Hair Pins on top to prevent the Hair Pin from being pulled out by tall grass or bushes.

Offsetting the Tow Bar Extension:

1. Remove the Hair Pin, Washer, and Clevis Pin that secures the Tow Bar Extension to the Tow Bar (**Figure 34**).
2. Rotate the Tow bar Extension so that the Offset angle is the same as at the Offset Bracket (No Offset, Middle Offset, or Full Offset).
3. Reinstall the Clevis Pin, Washer, and Hair Pin to Lock the Tow Bar Extension in Place.

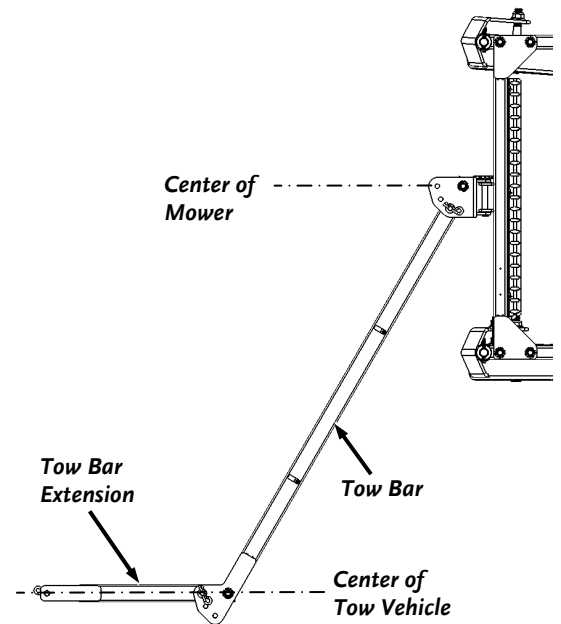

Figure 32: Full Offset Shown

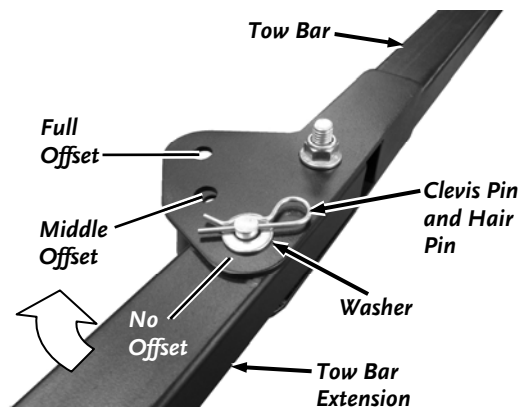

Figure 34

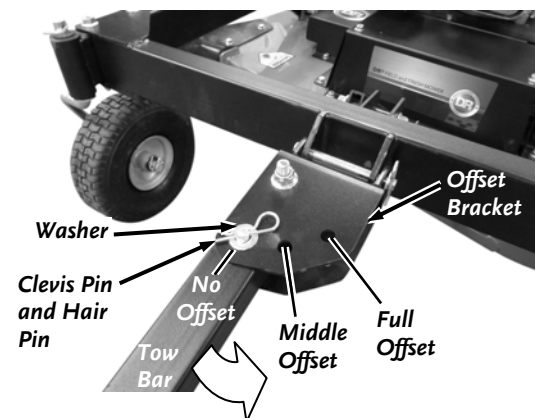

Figure 33

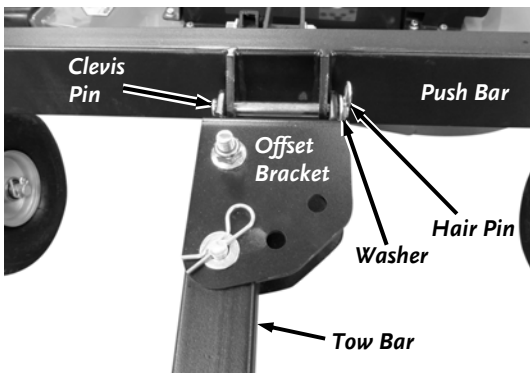

Figure 35

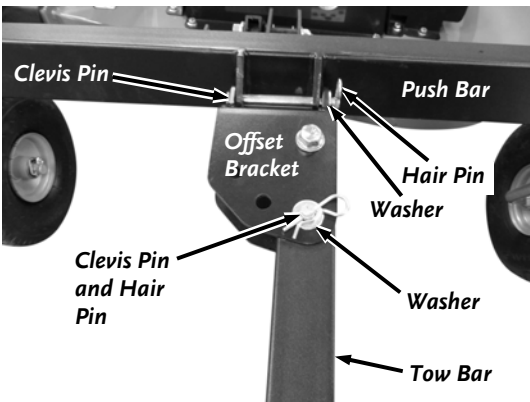

Figure 36

Changing the Tow Bar Offset Direction

The Tow Bar can be installed for offsetting to the right or left depending on which side of the tow vehicle you choose to mow. The following steps describe installing the Offset Bracket to allow offsetting to the left side of the Tow Vehicle.

1. Support the Tow Bar as you remove the Hair Pin, Washer and Clevis Pin that secures the Offset Bracket to the Push Bar (**Figure 35**).
2. Turn the Tow Bar over to position the Offset Bracket for left side offset (**Figure 36**).
3. Reinstall the Offset Bracket to the Push Bar with the Hair Pin, Washer and Clevis Pin.
4. Remove the Hair Pins, Washers and Clevis Pins that are at the Tow Bar and Tow Bar Extension offsets and reinstall with the Washers and Hair Pins on top.

! WARNING

Always install the Clevis Pins from the bottom with the Washers and Hair Pins on top to prevent the Hair Pin from being pulled out by tall grass or bushes.

5. To adjust the offset see section "Offset Mowing" on the previous page.

Slopes and Uneven Terrain

! WARNING

- Check the owner's manual for your tow vehicle to determine its recommended towing capabilities on slopes.
- When operating the TOW-BEHIND DR FIELD and FINISH MOWER over uneven terrain or slopes, use extreme caution not to tip over the machine.
- Never use the TOW-BEHIND DR FIELD and FINISH MOWER on slopes greater than 20 degrees. Doing so could result in serious injury or damage to your machine.
- If you have to mow on sloping terrain, mow up and down, never across the slope, for better control.

Cutting Wet and Heavy Growth

- Avoid steep slopes and other slippery areas.
- Use a lower, slower speed when mowing in wet conditions.

Chapter 4: Maintaining the TOW-BEHIND DR FIELD and FINISH MOWER

This chapter covers regular maintenance procedures that will ensure the best performance and long life of your TOW-BEHIND DR FIELD and FINISH MOWER. For Engine maintenance, please refer to the Engine Owner's Manual that came with your machine.

! WARNING

When performing any adjustment or maintenance, you must first disengage the Blade, shut off the engine, wait five minutes to allow parts to cool and disconnect the spark plug wire, keeping it away from the spark plug.

Service intervals listed in the checklist below supersede those listed in the Engine Owner's Manual.

Regular Maintenance Checklist

Note: Consider the service intervals shown as maximum under normal operating conditions. Increase frequencies under extremely dirty or dusty conditions.

PROCEDURE	BEFORE EACH USE	EVERY 25 HOURS	EVERY 100 HOURS
Check Engine Oil Level	▲		
Check General Condition, e.g. nuts, bolts, welds, etc.	▲		
Check the Blades Sharpness	▲		
Clean Engine Exterior & Cooling Fins	▲		
Check Tire Pressure of front and rear Wheels (psi on side of tire)		▲	
Change Engine Oil and Filter. Note: 1 st time after 5 hours		▲	
Replace Air Filter		▲	
Lubricate rear Wheel Bearings and Caster Shaft		▲	
Lubricate Height Adjustment Threads		▲	
Check Drive Belt Condition		▲	
Replace Spark Plug			▲
Replace In-line Gas Filter			▲

Lubrication

Tools and Supplies Needed:

- Grease gun with Multipurpose Automotive Grease
- Clean Rags

Lubricate Wheel Bearings and Casters:

1. Clean the Grease Fitting with a clean Rag (**Figure 37 and 38**).
2. Lubricate each Rear Wheel and Caster Shaft with Multipurpose Automotive Grease using a grease gun on the Grease Fitting.



Figure 37

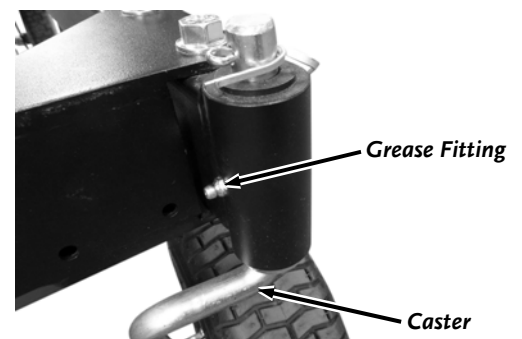

Figure 38

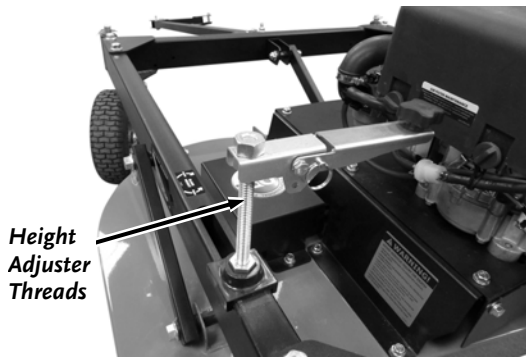

Figure 39

Lubricate Height Adjuster Threads

Tools and Supplies Needed:

- Wire Brush and Rags
- Super Lube

1. Raise the Deck to its highest position.
2. Clean any dirt or debris from the Height Adjuster threads with a Wire Brush and Rags (**Figure 39**).
3. Apply Super Lube to the full length of threads above and below the Frame Rail. It is very important to also lube at the base of the threads where they go through the Deck.
4. Lower the Deck to distribute the lubrication.

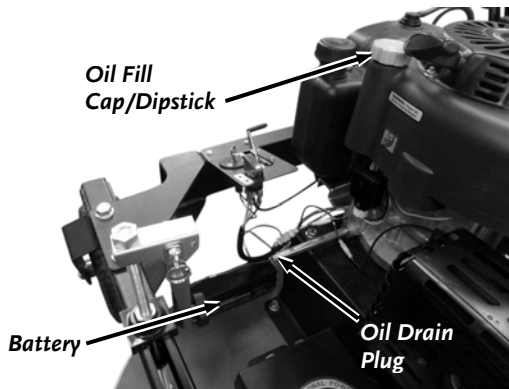

Figure 40

Removing and Replacing the Engine Oil (Mow Pro-44)

Note: Refer to the Engine Owner's manual for more detailed instructions for Engine maintenance. Drain the oil when the Engine is warm. Warm oil drains quickly and completely.

Tools and Supplies Needed:

- 7/16" Wrench
- 10mm Wrench
- 12mm Wrench
- Rags and an approved container for used oil
- SAE 30 High Detergent Oil

1. Remove the Oil Fill Cap/Dipstick (**Figure 40**).
2. Position an appropriate drain container near the Drain Plug.
3. Secure the Drain Tube by using a 12mm Wrench on the flats while you remove the Drain Plug using a 10mm Wrench. Replace the Drain Plug when finished draining.
4. Refill the oil by following the instructions in Chapter 2.

Note: Be sure to use environmentally safe disposal procedures in the disposing of the used oil.

Removing and Replacing the Engine Oil and Filter (Mow Pro-60)

Note: Refer to the Engine Owner's manual for more detailed instructions for Engine maintenance. Drain the oil when the Engine is warm. Warm oil drains quickly and completely.

Tools and Supplies Needed:

- Oil Filter Wrench (available at local auto parts or hardware store)
- Rags and an approved container for used oil
- SAE 30 High Detergent Oil

1. Remove the Oil Fill Cap/Dipstick (**Figure 41**).
2. Turn the Oil Drain Cap a quarter turn counterclockwise and open the end of the Drain Hose Assembly.
3. Position an appropriate drain container near the Drain Hose.
4. Remove the Oil Drain Hose Assembly from the Bracket and lower the Cap end over the Container to drain.
5. The Engine Oil Filter is located on the left side of the Engine (**Figure 42**). Using an Oil Filter Wrench, or grasping the Oil Filter firmly with your hand, unscrew the Oil Filter counterclockwise from the Engine. **BE SURE THAT THE OLD FILTER GASKET COMES OFF WITH THE FILTER.**
6. Wipe the mounting base for the Oil Filter with a clean cloth.
7. Apply a thin coat of clean motor oil to the new Oil Filter Gasket. **DO NOT USE GREASE OR USED OIL.**
8. Line up the threads carefully to avoid cross threading and screw the new Oil Filter on until the Filter Gasket contacts the base, and then tighten the Oil Filter 3/4 to 1 turn. **DO NOT OVER TIGHTEN.**
9. Mount the Oil Drain Hose Assembly onto the Bracket and replace the Oil Fill Cap.
10. Refill the oil by following the instructions in Chapter 2.

Note: Be sure to use environmentally safe disposal procedures in the disposing of the used oil.

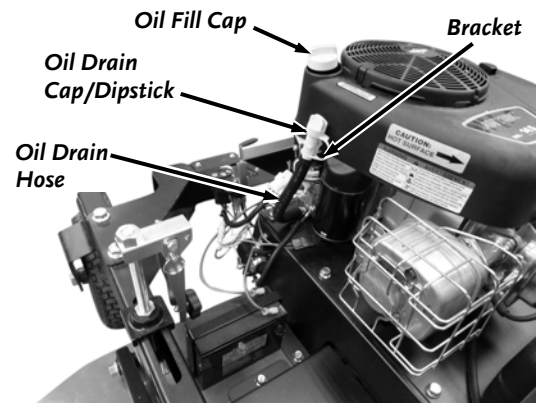

Figure 41

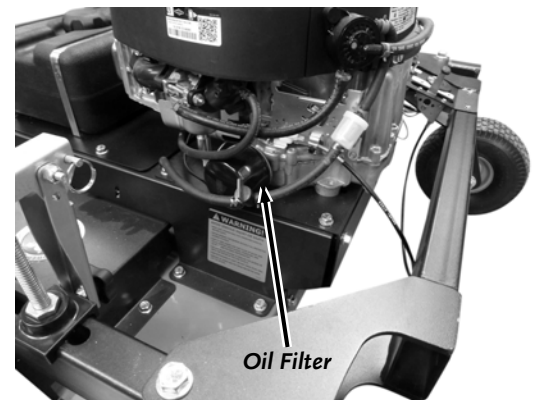

Figure 42

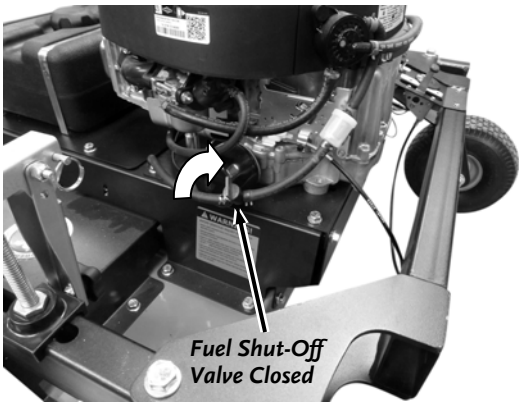

Figure 43

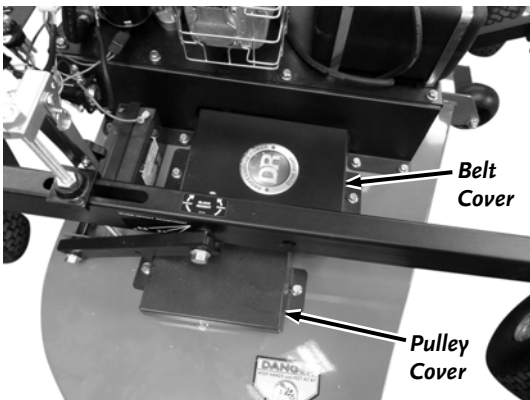

Figure 44

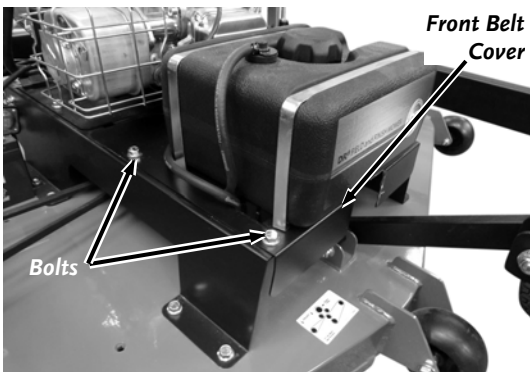

Figure 45

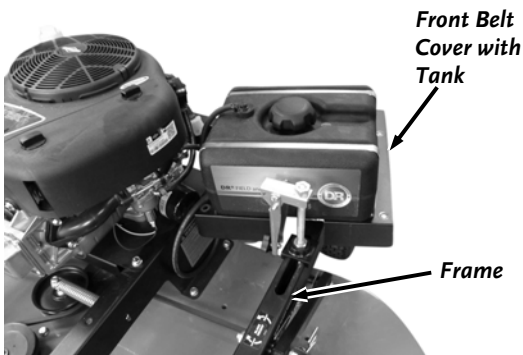

Figure 46

Removing and Replacing the Drive Belt

Tools Needed:

- 9/16" Wrench
- Gloves

NOTICE

Use only DR belts on your machine. They have been thoroughly tested and proven for many hours of use.

Removing the Belt

1. **Mow Pro-60 model only:** Turn the Fuel Shut-Off Valve to the Closed position (Figure 43).
2. Remove the two bolts from each of the two Pulley Covers using a 9/16" Wrench and remove the Covers (Figure 44).
3. Remove the two bolts from each of the two Belt Covers (Mow Pro-60 model only) using a 9/16" Wrench and remove the Covers.
4. Remove the six Bolts (Mow Pro-44 Model) or four bolts (Mow Pro-60 Model) securing the Front Belt Cover using a 9/16" Wrench and remove the Cover (Figure 45).
5. **Mow Pro-60 model only:** Position the Front Belt Cover with Tank at the left rear corner of the Frame (Figure 46).
6. At the rear of the machine, use a 9/16" Wrench to remove the three (Mow Pro-44) or four (Mow-Pro-60) Bolts securing the Rear Belt Cover and remove the Cover (Figure 47).
7. Loosen the Bolts securing the Belt Guides (*two for Pro-44 and three for Pro-60*) at the Blade Pulleys using a 9/16" Wrench (Figure 48). Rotate the Belt Guides away from the Pulleys.

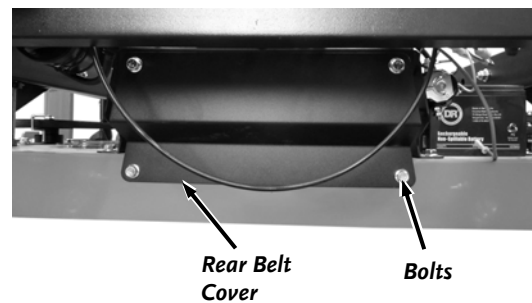

Figure 47

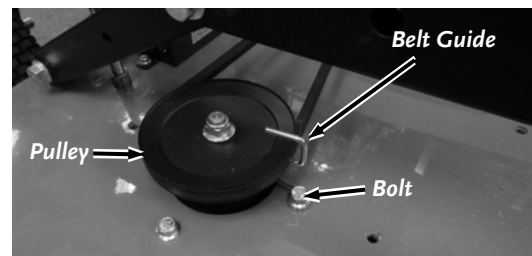

Figure 48

8. The Belt for the Mow Pro-44 can now be rolled off the pulleys and removed.
9. **Mow Pro-60 model only:** Release tension on the Belt by placing a 9/16" Wrench on the nut against the Tensioner Pulley and roll the Belt off the Blade Pulley (**Figure 49**).
10. **Mow Pro-60 model only:** Move the Belt up off the other Pulleys and remove the Belt between the Tensioner Pulley and left side Idler Pulley (**Figure 50**).

Note: The Mow Pro-60 Belt can only be removed and installed between the Tensioner Pulley and Idler Pulley.

11. Install the new Belt in the reverse order.

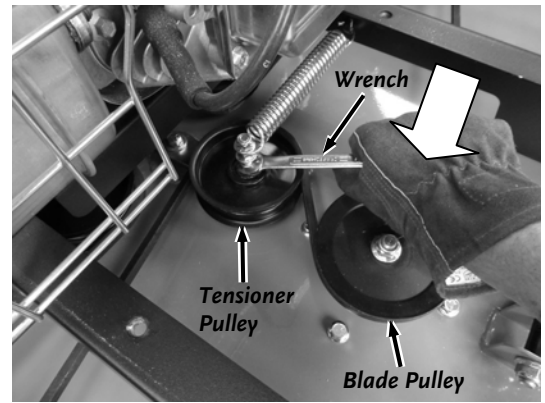

Figure 49

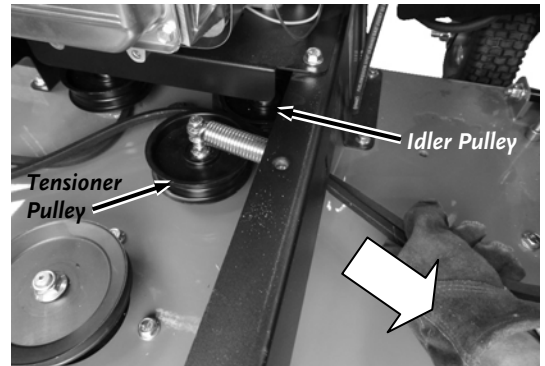

Figure 50

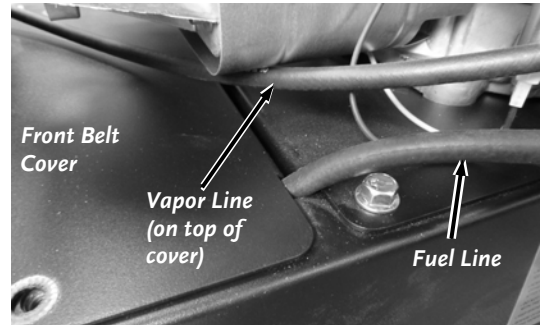

Figure 51

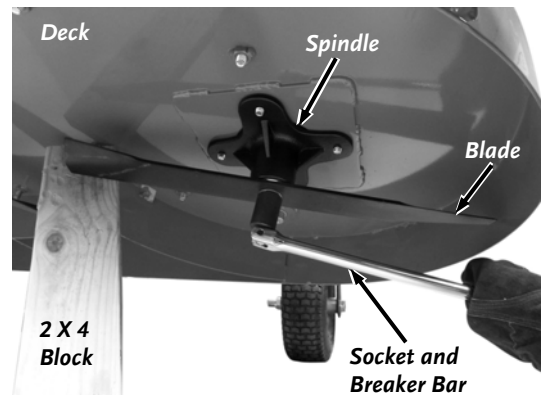

Figure 52

NOTICE

When positioning the Front Belt Cover, be careful not to stretch the Fuel and Vapor Lines. Ensure that the Fuel and Vapor Lines are routed through the opening and not pinched under the Gas Tank Plate (**Figure 51**).

Removing and Replacing the Blades

Note: Replace the Blades when worn or damaged.

Tools and Supplies needed:

- 3/4" Socket with 1/2" Breaker Bar
- Torque Wrench
- 2 x 4 Block or equivalent, length as needed
- Gloves

! WARNING

- Wear gloves and use caution when pushing or pulling the Breaker Bar next to the blade. If the Bar slips off the bolt you may be seriously injured.
- You will need a helper or a Jack to lift the rear of the machine to install Jack Stands. It is too heavy for one person to lift safely and could cause injury.

1. Disconnect the TOW BEHIND DR FIELD and FINISH MOWER from the Tow Vehicle.
2. Use Jack Stands or Ramps to support the front of the Mower off the Ground. Chock the rear wheels to prevent the Mower from moving.
3. Position the 2 x 4 between the Blades and Deck to stop the Blades from turning.
4. Remove the Bolts securing the Blades to Spindle using a 3/4" Socket and Breaker Bar. (**Figure 52**).
5. Secure the new or sharpened Blades with the Bolts using the 3/4" Socket and Torque Wrench. Torque Bolts to 30-35 ft-lbs
6. Lower the machine to the ground.

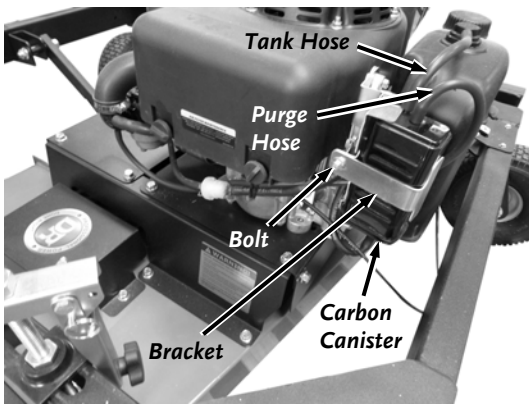

Figure 53

Replacing the Carbon Canister (Mow Pro-44 Model)

Tools needed:

- 5/16" Wrench
- Wire Cutters
- Pliers

1. Pull the two hoses from the top of the Carbon Canister (**Figure 53**).
2. Remove the bolt that secures the Canister Bracket using a 5/16" Wrench.
3. Remove the Bracket and Canister.
4. Install a new Carbon Canister and secure with the Bracket and Bolt using a 5/16" Wrench.

Note: The Hoses **MUST** be installed onto the new Canister in the same location as they were on the old Canister.

5. Install the Hoses at the top of the Canister.

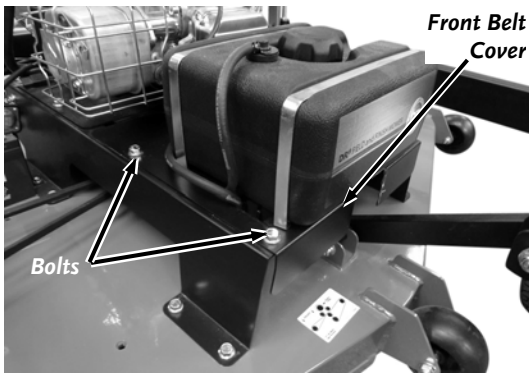

Figure 54

Replacing the Carbon Canister (Mow Pro-60 Model)

Tools needed:

- 9/16" Wrench
- Wire Cutters
- Pliers

1. Remove the four bolts securing the Front Belt Cover using a 9/16" Wrench and remove the Cover (**Figure 54**).
2. Position the Front Belt Cover so you have access to the Carbon Canister (**Figure 55**).

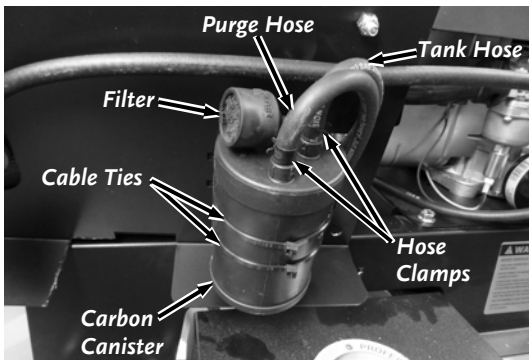

Figure 55

3. Cut the two Cable Ties that are securing the Carbon canister to the Gas Tank Plate using Wire Cutters.
4. Remove the rubber Filter Housing for better access to the Hose Clamps.
5. Slide the Hose Clamps away from the Hose connections using Pliers. Twist and pull the Hoses from the Canister.
6. Install the Hoses onto the new Carbon Canister and position the Hose Clamps with Pliers.

Note: The Hoses **MUST** be installed onto the new Canister in the same location as they were on the old Canister. The Canister is labeled "Purge" (this hose is from the engine) and "Tank" (this hose is from the top of the fuel tank).

7. Slide new Cable Ties through the cutouts in the Front Belt Cover and position the Canister.
8. Tighten the Cable Ties around the Canister and cut the excess with Wire Cutters.
9. Reinstall the Gas Tank Support making sure that the Hose are in the proper location and do not get pinched (**Figure 56**).

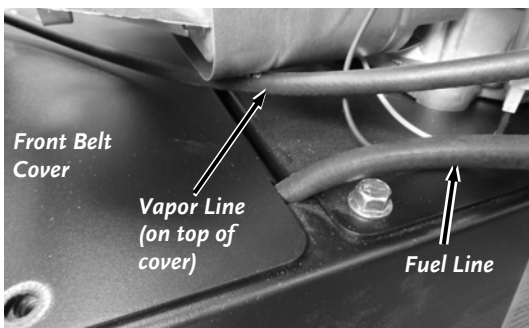

Figure 56

Battery Care (Electric Start Model Only)

Proper care can extend the life of a Battery. Follow these recommendations to ensure your Battery's best performance and long life:

- Do not allow the Battery charge to get too low. If the machine is not used, charge the Battery every 4 – 6 weeks. Operate the Engine for at least 45 minutes to maintain proper Battery charge.
- Store an unused Battery in a dry area that does not freeze.
- Do not charge an already charged Battery. In theory, you cannot overcharge our Battery with a trickle Charger; however, when a Battery is fully charged and the Charger is still on, it generates heat that could be harmful to the Battery. A fully charged Battery will read 12V-13.2V with a Voltmeter.
- Do not continue to crank the Engine when the Battery charge is low.

Disposing of the Battery Responsibly

The Battery is a sealed lead-acid Battery. Recycle or dispose of it in an environmentally sound way.

- Do not dispose of a lead-acid Battery in a fire; the Battery may explode or leak.
- Do not dispose of a lead-acid Battery in your regular, household trash. Laws in most areas prohibit incinerating, disposing in a landfill, or mixing a sealed lead-acid Battery with household trash.

Charging the Battery

Operate the Mower Engine for at least 45 minutes to maintain proper Battery charge. If the Battery loses its charge, you'll need to use a trickle Charger (like the DR Battery Charger) to recharge it. The Charger should have an output of 12 volts at no more than 2 amps.

Note: *The charging system of a running engine is designed to maintain a battery's present charge. Starting a machine that has a significantly discharged or dead Battery using the Recoil Starter or Jumper Cables will not recharge the Battery.*

To connect a Battery Charger to your TOW BEHIND DR FIELD and FINISH MOWER, follow the steps listed below.

1. Detach the two Battery wires going to the Battery on your Mower.
2. Attach the black (-) Battery Charger wire to the Battery negative (-) terminal, and attach the red (+) Battery Charger wire to the Battery positive (+) terminal.
3. Plug the Battery Charger into an outlet.
4. Charge until Battery Charger indicates that it is charged or Battery measures to 12-14V
 - At 1 amp, you may have to charge the Battery for as long as 24 hours.
 - At 2 amps, you may have to charge the Battery for as long as 12 hours.
5. Once Charged, disconnect Charger from outlet
6. Disconnect Battery from the Charger.
7. Reconnect the Battery Wires.

Recycling a Used Battery

NOTICE

Please dispose of used batteries responsibly, according to your local hazardous materials regulations. Never throw away used batteries in your household trash.

Please dispose of your used Batteries responsibly by recycling them. Call your local Solid Waste Management District or your local waste handler to locate the collection site nearest you. Some collection sites recycle Batteries year-round; others collect them periodically.

Visit these sites for more information:

- Web site of Earth 911 [www.earth911.com]
- International Metals Reclamation Company [www.inmetco.com]
- Battery Council International [www.batterycouncil.org]
- Environmental Protection Agency [www.epa.gov]

Chapter 5: Troubleshooting

Most problems are easy to fix. Consult the Troubleshooting Table below for common problems and their solutions. If you continue to experience problems, contact us at www.DRpower.com or call toll-free 1-800-DR-OWNER (376-9637) for support.

WARNING

When performing any adjustment or maintenance, you must first shut off the engine, wait five minutes to allow parts to cool and disconnect the spark plug wire, keeping it away from the spark plug.

Troubleshooting Table

SYMPTOM	POSSIBLE CAUSE
<p><i>The Engine will not start.</i></p> <p><i>(Please refer to the Engine Owner's Manual for Engine-specific procedures.)</i></p>	<ul style="list-style-type: none"> ⇒ Check all the items under the section called "Starting" in Chapter 3. ⇒ Check that the Blade Switch Safety Cover is DOWN in the Disengaged position. ⇒ Make sure the Spark Plug wire is attached. ⇒ If the Engine is cold, make sure the Throttle is in the CHOKE position. See "Starting" in Chapter 3. ⇒ The gas must be fresh and clean. If the gas is old, change it. Use a fuel stabilizer if you keep gas longer than one month. ⇒ The Spark Plug may be dirty or cracked, change it. ⇒ If the Spark Plug is oily, leave it out, hold a rag over the Plug hole and crank the Engine over a couple of times using the Electric Starter (Mow Pro-60) or Starter Cord (Mow Pro-44) to blow out any oil in the Cylinder, then wipe off the Plug and reinsert it. ⇒ The Air Filter may be dirty, change it following the procedure in the Engine Owner's Manual. ⇒ There are two Fuses in the Wiring Harness. Check the Fuses and replace if needed. ⇒ Check the wire connections—especially the ground connection, the large green wire coming from the Battery, where it connects to the Engine. ⇒ The Battery may not be charged. Check the voltage yourself or at a service station. If it is low, charge it with a 12-volt, 1 to 2-amp trickle charger. If you do not use your machine for at least 45 minutes at a time, the Battery may need to be periodically charged. See the "Battery Care" section in Chapter 4. ⇒ If the Battery is charged and the DR TOW-BEHIND FIELD and FINISH MOWER still will not start (Mow Pro-60), visit our website at www.DRpower.com.
<p><i>The Engine lacks power or is not running smoothly.</i></p> <p><i>(Please refer to the Engine Owner's Manual for Engine-specific procedures.)</i></p>	<ul style="list-style-type: none"> ⇒ The Throttle Lever may be in the wrong position; Make sure the Throttle Lever is in the RUN position. ⇒ The Air Filter may be dirty, change it following the procedure in the Engine Owner's Manual. ⇒ The Spark Plug may be dirty or cracked, change it. ⇒ If the Spark Plug is oily, leave it out, hold a rag over the Plug hole and crank the Engine over a couple of times using the Electric Starter (Mow Pro-60) or Starter Cord (Mow Pro-44) to blow out any oil in the Cylinder, then wipe off the Plug and reinsert it. ⇒ The gas must be fresh and clean. If the gas is old, change it. Use a fuel stabilizer if you keep gas longer than one month. ⇒ The Engine may not have the right amount of clean oil. If it is dirty, change it following the procedure in Chapter 4. ⇒ If the Engine still lacks power, visit our website at www.DRPower.com.

! WARNING

When performing any adjustment or maintenance, you must first shut off the engine, wait five minutes to allow parts to cool and disconnect the spark plug wire, keeping it away from the spark plug.

Troubleshooting Table (Continued)

SYMPTOM	POSSIBLE CAUSE
<i>Engine smokes.</i>	<ul style="list-style-type: none">⇒ Check the oil level and adjust as needed.⇒ You may be operating the machine on too great an incline. See “Slopes and Uneven Terrain” in Chapter 3⇒ Check the Air Filter(s) and clean or replace if needed.⇒ You may be using the wrong oil—too light for the temperature. Refer to your Engine Owner’s Manual for detailed information.⇒ Clean the Cooling Fins and the Carburetor housing if they are dirty.⇒ If the Engine still smokes, visit our website at www.DRpower.com for assistance
<i>The Belt frays or rolls over the Pulley.</i>	<ul style="list-style-type: none">⇒ There may be a nick in a Pulley groove. Check the Belt for wear and hard spots. File off any nicks on the Pulley.⇒ The Belt may be stretched; replace it. See Chapter 4.
<i>Blades vibrate when engaged.</i>	<ul style="list-style-type: none">⇒ The Blade Mounting Bolt may not be tight enough. Tighten the Bolt as tight as possible with a Breaker Bar and 3/4" Wrench.⇒ Replace a Blade if it is chipped, bent, or broken.⇒ The Spindle Bearings may be damaged or the Spindle Shaft is bent.⇒ If the Blades still vibrate, visit our website at www.DRpower.com for assistance.
<i>The Blades are not cutting or are loose.</i>	<ul style="list-style-type: none">⇒ The Blade Mounting Bolt may not be tight enough. Tighten the Bolt as tight as possible with a Breaker Bar and 3/4" Wrench.⇒ Sharpen the Blades; they may be dull or nicked.
<i>The Blades will not Engage and/or Disengage.</i>	<ul style="list-style-type: none">⇒ Faulty Blade Control Switch. Remove and replace the Switch on the Control Panel.⇒ Faulty Electric Clutch. Visit our website at www.DRpower.com for assistance.⇒ Low or weak battery may cause electric clutch to not engage. Check battery for sufficient voltage.
<i>Uneven cut.</i>	<ul style="list-style-type: none">⇒ Left and Right Deck Height Adjusters are not at the same setting.
<i>Excessive Engine stalling.</i>	<ul style="list-style-type: none">⇒ The grass is too heavy at the current cutting height or at the current Tow Vehicle speed. Raise the cutting height and drive slower when cutting.

Chapter 6: Parts Lists and Schematic Diagrams

Parts List – Frame and Tow Bar

Note: Part numbers listed are available through DR Power Equipment.

<u>Ref#</u>	<u>Part#</u>	<u>Description</u>	<u>Ref#</u>	<u>Part#</u>	<u>Description</u>
1	35495	Bracket, Offset	16	34511	Bolt, Hex, Flange, 1/2-13 X 3", Gr5, ZP
2	37366	Support, Wheels, Finish, Right, With Labels	17	36573	Bolt, Hex, Flange, 1/2-13 X 4.5", Gr5, ZP
3	37367	Support, Wheels, Finish, Left, With Labels	18	33348	Bolt, Hex, Flange, 3/8-16 X 2.5"
4	37349	Label, Height Adjust, Right	19	33338	Nut, Nylon Lock, Flanged, 3/4-10
5	37125	Label, Crank Direction	20	33335	Nut, Nylon Lock, Flanged, 1/2-13
6	37350	Label, Height Adjust, Left	21	33333	Nut, Nylon Lock, Flanged, 3/8-16
7	37383	Push Bar	22	18064	Washer, .8" ID, 1.5" OD X .11"
8	36272	Brace, Rear	23	23499	Washer, SAE Flat, 1/2", ZP
9	37168	Bracket, Push Bar	24	18655	Pin, Cotter, 3/16" x 2"
10	37145	Wheel, Pneumatic, Turf Saver Tread, 11 X 4 Tire, 5" Hub	25	25549	Pin, Clevis, 1/2" X 2 1/2"
11	37144	Caster	26	18737	Pin, Clevis, 1/2" OD X 4.5" Lg
12	37342	Wheel, Pneumatic, Turf Saver Tread, 11 X 4, Sealed Bearing	27	16003	Pin, Hair, 1/2" To 9/16", .12" Wire
13	35496	Tow Bar	28	10189	Grease Fitting 1/4-28 Straight
14	35497	Extension, Tow Bar	29	37353	Label, QR Code
15	34324	Bolt, HCS, 3/4-10 X 7", ZP	30	12376	Bushing, .766" ID, 1.0" OD

Schematic – Frame and Tow Bar

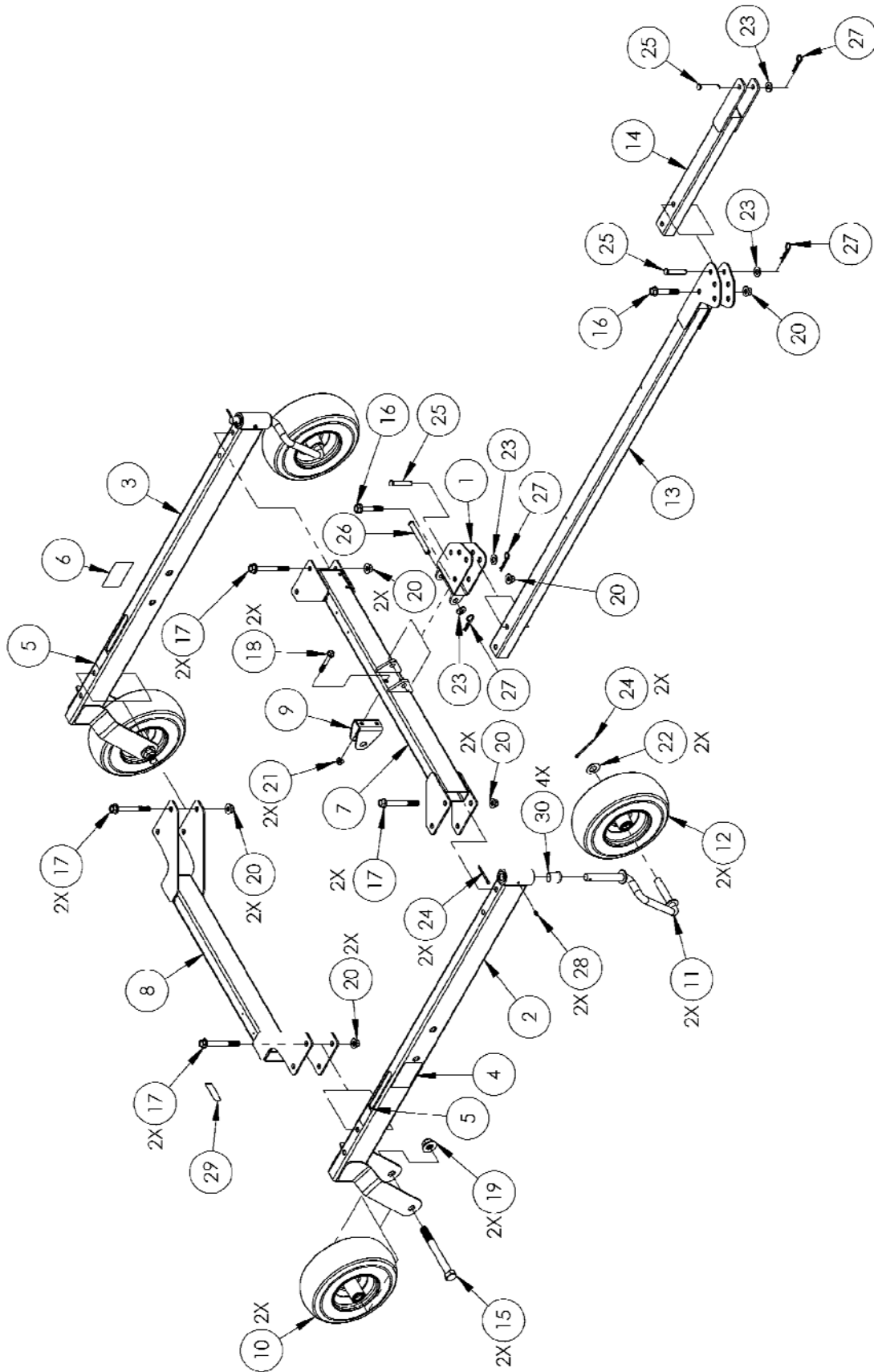

Parts List – Deck and Deck Lift (Mow Pro-44)

Note: Part numbers listed are available through DR Power Equipment.

Ref#	Part#	Description	Ref#	Part#	Description
1	37369	Deck, Finish Mowing, 44" Wide, With Labels	21	15127	Pulley, Flat Idler, 4"
2	13649	Label, Danger, Blade	22	36281	Belt, A76
3	37354	Label, Belt Routing	23	15094	Spring, E, .750" OD X .112" Wire
4	37381	Cover, Pulleys, With Labels	24	37159	Belt Guide, Wire
5	36574	Shim, Nylon, .76" ID X .131" OD X .06" THK	25	37157	Blade, Mowing, 22-1/4"
6	34139	Label, DR Logo, 4" Black	26	36572	Bolt, Hex, Flange, 1/2-13 X 3.5", GR5, ZP
7	36298	Guard, Discharge	27	36563	Bolt, Hex, Flange, 1/2-13 X 1.25", GR5, ZP
8	37158	Rod Assembly, Height Adjust, Acme Thread	28	11465	Bolt, HCS Ft, 3/8-16 X 3", GR5, ZP
9	36289	Bushing, Sway Brace	29	33348	Bolt, Hex, Flange, 3/8-16 X 2.5"
10	35494	Brace, Sway	30	15712	Bolt, HCS, 3/8-16 X 2-1/4", GR5, ZP
11	35499	Block, Height Adjust	31	35281	Bolt, Hex, Flange, Tri Lobe, 3/8-16 X 3/4", GR5 ZP
12	36254	Crank, Hand	32	11148	Bolt, HCS, 1/4-20 X 1.75", GR5, ZP
13	37121	Crank, Hand, Break-Away	33	33335	Nut, Nylon Lock, Flanged, 1/2-13
14	36576	Knob, 4-Lobe, 5/16-18 X 1/2" Stud, ZP	34	36575	Nut, Acme, 1/2-10, GR2, ZP
15	32341	Collar, Shaft, 1/2", Clamp-On	35	33333	Nut, Nylon Lock, Flanged, 3/8-16
16	36280	Spindle, Assembly, Finish	36	18755	Nut, Nylon Lock, 5/16-18, LP
17	36264	Pulley, 5" OD, 0.75" Bore, A/B Profile	37	11073	Nut, Nylon Lock, 1/4-20, ZP
18	37169	Key, ANSI #605 Woodruff, 3/16" X 5/8"	38	11239	Washer, Flat, 3/8", USS
19	37382	Idler Arm	39	22253	Washer, Lock, 3/8"
20	37166	Spacer, 3/8" ID, 1-3/8" OD, 3/4" THK	40	36577	Detent Pin, Grip Ring, 1/4" X 1-1/4", ZP
			41	36258	Bushing, .380" X .664" X .9"

Schematic – Deck and Deck Lift (Mow Pro-44)

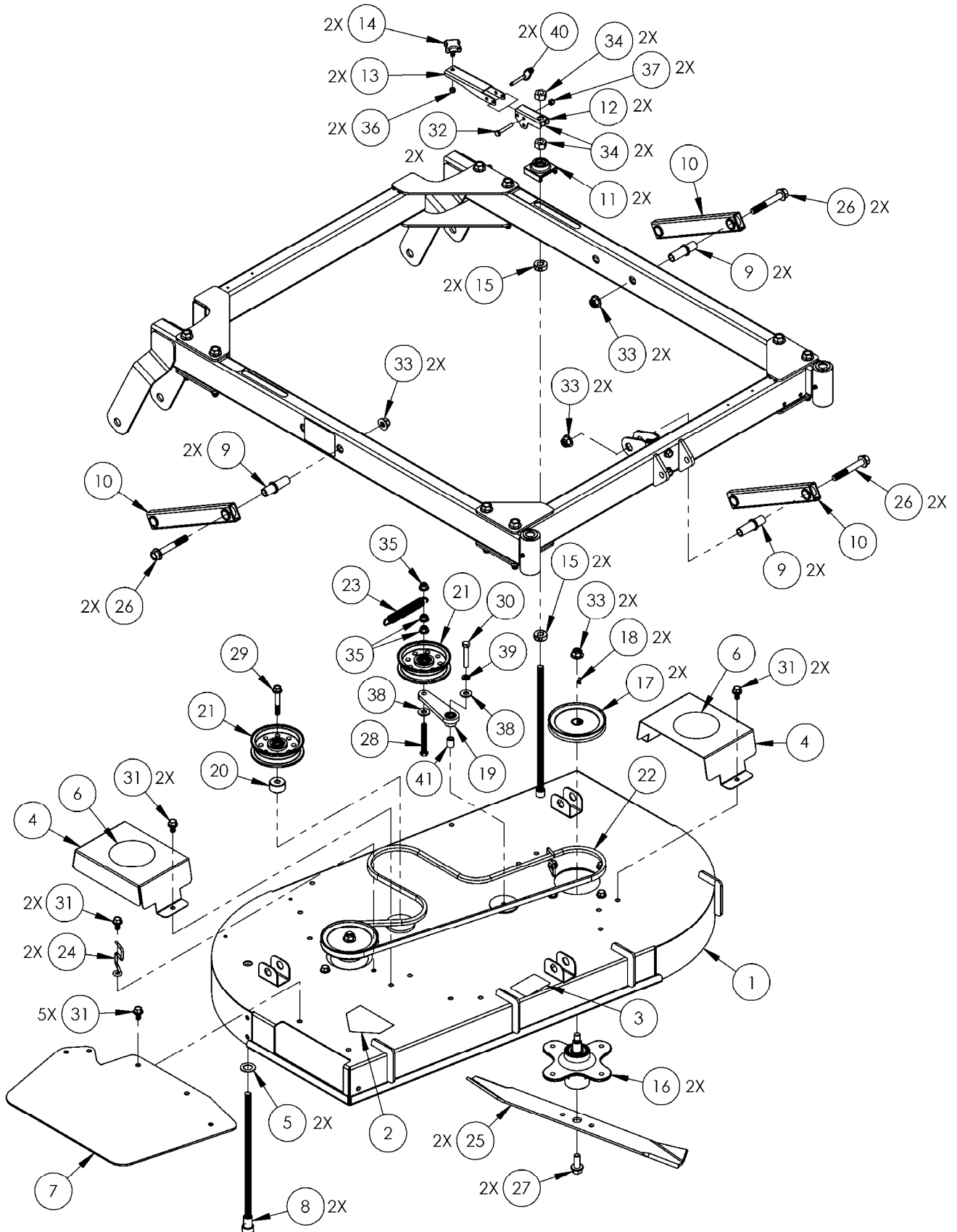

Parts List – Deck and Deck Lift (Mow Pro-60)

Note: Part numbers listed are available through DR Power Equipment.

Ref#	Part#	Description	Ref#	Part#	Description
1	37368	Deck, Finish Mowing, 60" Wide, With Labels	23	37166	Spacer, 3/8" ID, 1-3/8" OD, 3/4" Thk
2	36574	Shim, Nylon, .76" ID X .1.31" OD X .06" THK	24	15127	Pulley, Flat Idler, 4"
3	13649	Label, Danger, Blade	25	36258	Bushing, .380" X .664" X .9"
4	37355	Label, Belt Routing, 60	26	37382	Idler Arm
5	36577	Detent Pin, Grip Ring, 1/4" X 1-1/4", ZP	27	38551	Belt, AK124, General Purpose Cover
6	37384	Cover, Belt, 60, With Labels	28	37341	Spring, 1.00" OD, .135" Wire, 5.5"L
7	34139	Label, DR Logo, 4" Black	29	36563	Bolt, Hex, Flange, 1/2-13 X 1.25", Gr5, ZP
8	37161	Cover, Pulleys	30	36572	Bolt, Hex, Flange, 1/2-13 X 3.5", Gr5, ZP
9	36298	Guard, Discharge	31	36573	Bolt, Hex, Flange, 1/2-13 X 4.5", Gr5, ZP
10	15708	Wheel Anti-Scalping	32	11465	Bolt, HCS Ft, 3/8-16 X 3", Gr5, ZP
11	37158	Rod Assembly, Height Adjust, Acme Thread	33	33348	Bolt, Hex, Flange, 3/8-16 X 2.5"
12	36289	Bushing, Sway Brace	34	15712	Bolt, HCS, 3/8-16 X 2-1/4", GR5, ZP
13	35494	Brace, Sway	35	35281	Bolt, Hex, Flange, Tri Lobe, 3/8-16 X 3/4", GR5 ZP
14	35499	Block, Height Adjust	36	15713	Screw, Shoulder, 3/8-16
15	36254	Crank, Hand	37	33335	Nut, Nylon Lock, Flanged, 1/2-13
16	37121	Crank, Hand, Break-Away	38	36575	Nut, Acme, 1/2-10, Gr2, ZP
17	36576	4-Lobe Knob, 5/16-18 X 1/2" Stud, ZP	39	33333	Nut, Nylon Lock, Flanged, 3/8-16
18	37156	Blade, Mowing, 20-1/2"	40	18755	Nut, Nylon Lock, 5/16-18, LP
19	36280	Spindle, Assembly, Finish	41	11239	Washer, Flat, 3/8", USS
20	37159	Belt Guide, Wire	42	22253	Washer, Lock, 3/8"
21	36264	Pulley, 5" OD, 0.75" Bore, A/B Profile	43	32341	Collar, Shaft, 1/2", Clamp-On
22	37169	Key, ANSI #605 Woodruff, 3/16" X 5/8"	44	11148	Bolt, HCS, 1/4-20 X 1.75", GR5, ZP
			45	11073	Nut, Nylon Lock, 1/4-20, ZP

Schematic – Deck and Deck Lift (Mow Pro-60)

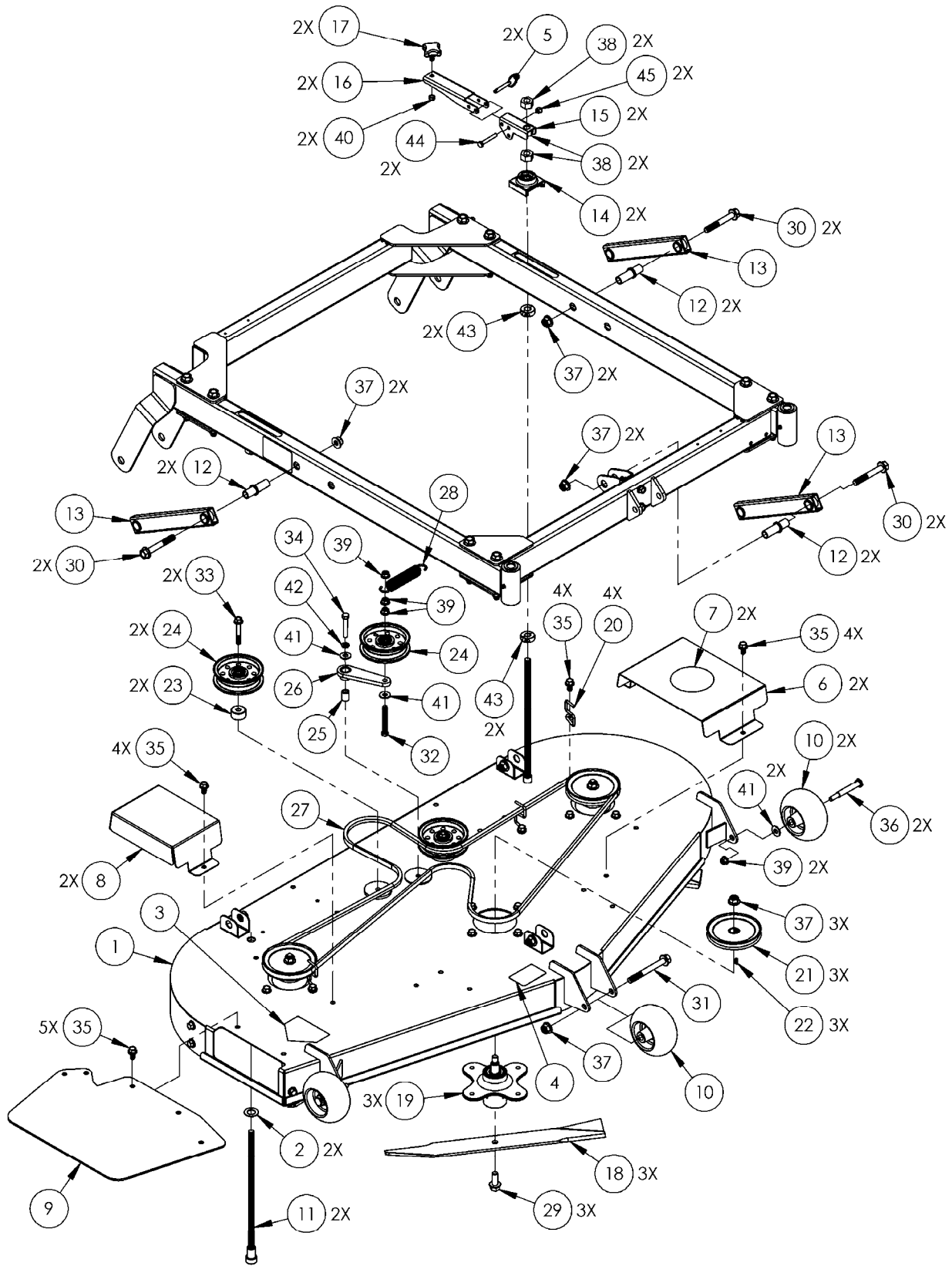

Parts List – Drive, Gas and Control (Mow Pro-44)

Note: Part numbers listed are available through DR Power Equipment.

<u>Ref#</u>	<u>Part#</u>	<u>Description</u>	<u>Ref#</u>	<u>Part#</u>	<u>Description</u>
1	37371	Rail Support, Left, 44, With Labels	20	13758	Label, Check Oil, 2.75" x .63"
2	37122	Label, Warnings	21	13683	Label, Caution, Hot Surface
3	37165	Rail Support, Right, 44	22	22252	Washer, Lock, 7/16", Split, ZP
4	36275	Mount, Engine, Finish	23	19130	Washer, Flat, .469" X 1.62" X .25"
5	37376	Cover, Belt, Front, 44, With Labels	24	37132	Bolt, HCS, M10-1.25 X 50, Cl10, ZP
6	37348	Label, Branding	25	11465	Bolt, HCS Ft, 3/8-16 X 3", GR5, ZP
7	37167	Cover, Belt, Rear, 44	26	35281	Bolt, Hex, Flange, Tri Lobe, 3/8-16 X 3/4", GR5 ZP
8	37136	Control Panel, With Labels			
9	36585	Label, Throttle Control	27	11250	Washer, Lock, 1/4", External Tooth
10	36584	Label, Blade Engage	28	15045	Bolt, HCS, 5/16-18 X 1-3/4", GR5, ZP
11	36549	Cable, Throttle, 30 L	29	11069	Nut, Hex, 5/16-18, GR2, ZP
12	36305	Safety Cover, Toggle Switch	30	11170	Screw, 10-32 X 1/2", Type F, Hex, ZP
13	36304	Switch, Toggle, Dpdt	31	15049	Screw 8-32 x 1/2"
14	22142	Spacer, 1.00" ID X 1.75" OD X 1.25"	32	33333	Nut, Nylon Lock, Flanged, 3/8-16
15	33386	Clutch, Electric, 75 Ft-Lbs	33		
16	16520	Switch, Snap-In, M/S	<u>Not Shown</u>		
17	38571	Engine, DR, 13.3tq, 340cc, M/S, 50st/CE, W/ Labels		37347	Wire Harness, Machine, Local, M/S
18	11239	Washer, Flat, 3/8", USS		15720	Key Ignition Switch
19	37147	Tube, Oil Drain, RV340		37386	Carbon Canister, RV340

Schematic – Drive, Gas and Control (Mow Pro-44)

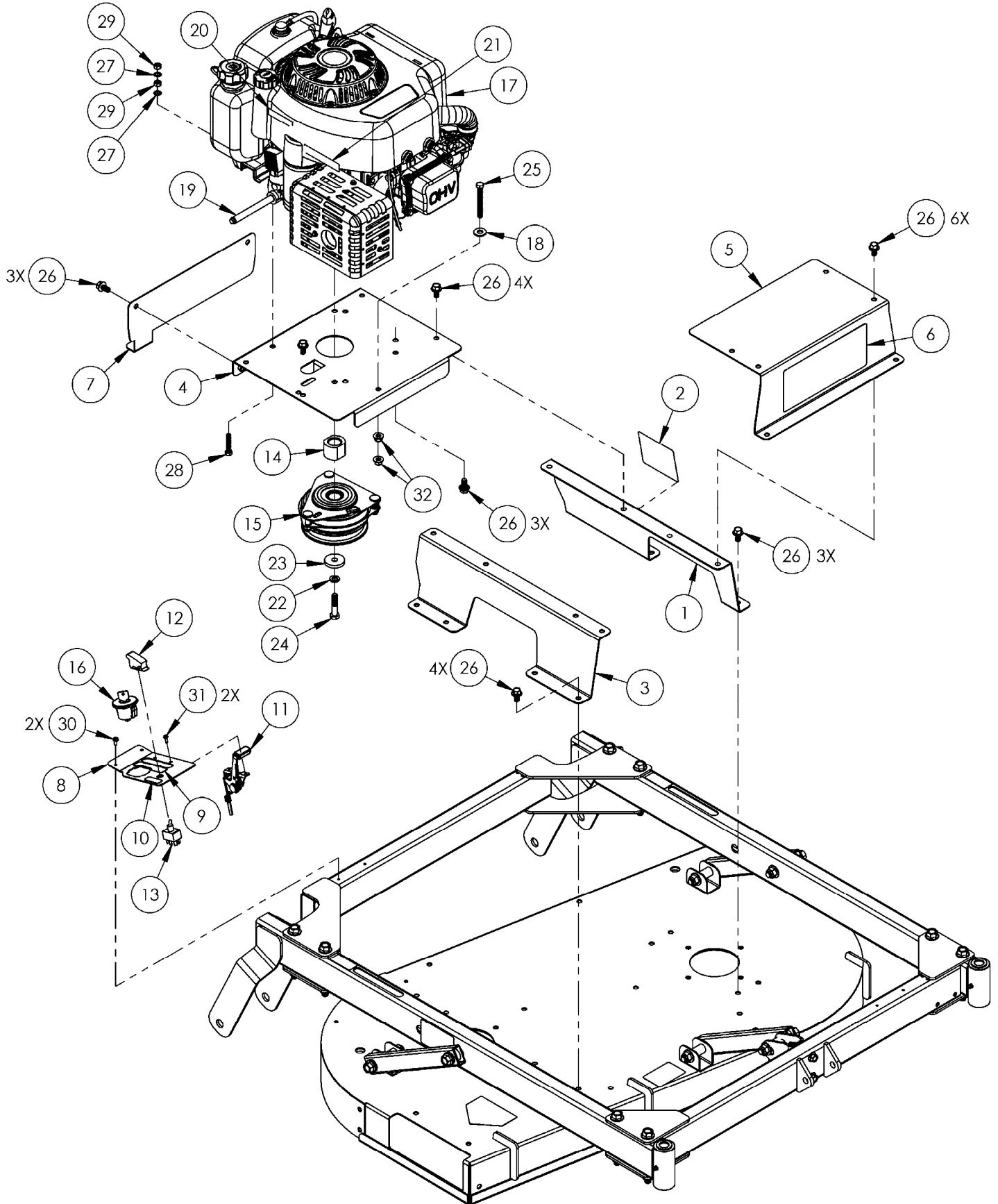

Parts List – Drive, Gas and Control (Mow Pro-60)

Note: Part numbers listed are available through DR Power Equipment.

Ref#	Part#	Description	Ref#	Part#	Description
1	39111	Rail Support, Left, 3/8" Straps, 60, With Labels	28	31283	Nut, Lock, 1/4-20, Serrated Flange
2	12797	Cable Tie, 17", # 50	29	33333	Nut, Nylon Lock, Flanged, 3/8-16
3	37122	Label, Warnings	30	24230	Strap, Battery, 9Ah
4	39107	Rail Support, Right, 3/8" Straps, 60	31	11069	Nut, Hex, 5/16-18, GR2, ZP
5	36275	Mount, Engine	32	15049	Screw, 8-32 x 1/2"
6	39106	Support, Gas Tank, 3/8" Straps, Finish	33	36554	Wire Harness, Machine, Local, E/S
7	36276	Cover, Belt, Rear, 60	34	11170	Screw, 10-32 X 1/2", Type F, Hex, ZP
8	13447	Battery, 12V, 9Ah	35	37113	Hose Fuel Ca Cert, 2" Long, W/ Clamps
9	38570	Fuel Tank Assy, 2.5 Gal, With Labels	36	10066	Clamp Fuel Line
10	11250	Washer, Lock, 5/16", Ext Tooth, ZP	37	31117	Bolt, HWH, 1/4-20 x .75", Taptite
11	37348	Label, Branding	38	37373	Hose Fuel Ca Cert, 22" Long, W/ Clamps
12	38581	Strap, Tank, 3/8" Studs	39	15045	Bolt, HCS, 5/16-18 X 1-3/4", Gr5, ZP
13	38530	Carbon Canister, 300cc, 1/4" Tank, 3/16" Purge	40	36286	Valve, Fuel Shutoff
14	37067	Engine, B&S, 14.5hp Intek, E/S, 6- Pin, W/ Labels	41	22214	Bolt, 7/16-20 X 2-1/4", GR8, ZP
15	22252	Washer, Lock, 7/16", Split, ZP	42	38568	Hose, Vapor, 1/4" ID, 15" Long, W/ Clamps
16	13758	Label, Check Oil, 2.75" X .63"	43	26581	Clamp, Vapor Line
17	13683	Label, Caution, Hot Surface	44	35281	Bolt, Hex, Flange, Tri Lobe, 3/8-16 X 3/4", Gr5 ZP
18	22142	Spacer, 1.00" ID X 1.75" OD X 1.25"	45	37374	Hose, Vapor, 3/16" ID, 42" Long, W/ Clamps
19	33386	Clutch, Electric, 75 Ft-Lbs	Not Shown		
20	37136	Control Panel, With Labels	342751	Wire, Battery, Ground	
21	19130	Washer, Flat, .469" X 1.62" X .25"	343331	Deflector, Briggs	
22	36585	Label, Throttle Control	343311	Muffler Guard, B&S	
23	36584	Label, Blade Engage	343341	Static Cover, Briggs	
24	36549	Cable, Throttle, 30" L	15720	Key Ignition Switch	
25	22223	Switch, Snap-On, E/S	34332	Screw, Guard, B&S	
26	36304	Switch, Toggle, DPDT	34335	Screw, B&S, Static Cover	
27	36305	Safety Cover, Toggle Switch			

Notes:

TOW-BEHIND DR[®] FIELD and FINISH MOWER



2-Year Limited Warranty Terms and Conditions

The TOW-BEHIND DR[®] FIELD and FINISH MOWER is warranted for two (2) years against defects in materials or workmanship when put to ordinary and normal consumer use; ninety (90) days for any other use. The Engine manufacturer warrants the Engine separately. The Battery is warranted for one (1) year.

For the purposes of all the above warranties, "ordinary and normal consumer use" refers to non-commercial residential use and does not include misuse, accidents, or damage due to inadequate maintenance.

DR Power Equipment certifies that the DR[®] FIELD and FINISH MOWER is fit for ordinary purposes for which a product of this type is used. DR Power Equipment however, limits the implied warranties of merchantability and fitness in duration to a period of two (2) years in consumer use, ninety (90) days for any other use except all emission related components. DR Power Equipment limits the implied warranties of merchantability and fitness in duration to a period of two (2) years for all emissions related components. The Engine manufacturer warrants the Engine separately. The Battery is warranted for one (1) year.

The 2-Year Limited Warranty on the TOW-BEHIND DR[®] FIELD and FINISH MOWER starts on the date the machine ships from our factory. The 2-Year Limited Warranty is applicable only to the original owner.

The warranty holder is responsible for the performance of the required maintenance as defined by the manufacturer's owner's manuals. The warranty holder is responsible for replacement of normally wearing parts such as the Drive Belts, Blades, Battery, Spark Plug and Filters (Air and Oil). This warranty does not cover attachments and accessories to the machine.

During the warranty period, the warranty holder is responsible for the machine transportation charges, if required. During the warranty period, warranty parts will ship by standard method at no charge to the warranty holder. Expedited shipping of warranty parts is the responsibility of the warranty holder.

SOME STATES DO NOT ALLOW LIMITATIONS ON THE LENGTH OF IMPLIED WARRANTIES, SO THE ABOVE LIMITATIONS MAY NOT APPLY TO YOU.

DR[®] Power Equipment shall not be liable under any circumstances for any incidental or consequential damages or expenses of any kind, including, but not limited to, cost of equipment rentals, loss of profit, or cost of hiring services to perform tasks normally performed by the TOW-BEHIND DR[®] FIELD and FINISH MOWER.

SOME STATES DO NOT ALLOW THE EXCLUSION OR LIMITATION OF INCIDENTAL OR CONSEQUENTIAL DAMAGES, SO THE ABOVE LIMITATIONS MAY NOT APPLY TO YOU.

THIS WARRANTY GIVES YOU SPECIFIC LEGAL RIGHTS, AND YOU HAVE OTHER RIGHTS, WHICH VARY FROM STATE TO STATE.

Warranty

CALIFORNIA EVAPORATIVE EMISSION CONTROL WARRANTY STATEMENT

YOUR WARRANTY RIGHTS AND OBLIGATIONS

The California Air Resources Board and Country Home Products, Inc. are pleased to explain the evaporative emission control system warranty on your 2018 DR® Field and Finish Mower. In California, new equipment that use small off-road engines must be designed, built and equipped to meet the State's stringent anti-smog standards. Country Home Products, Inc. must warrant the evaporative emission control system on your DR® Field and Finish Mower for the period of time listed below provided there has been no abuse, neglect or improper maintenance of your equipment.

Your evaporative emission control system may include parts such as the carburetor, fuel-injection system, the ignition system, catalytic converter, fuel tanks, fuel lines, fuel caps, valves, canisters, filters, vapor hoses, clamps, connectors, and other associated emission-related components.

MANUFACTURER'S WARRANTY COVERAGE:

This evaporative emission control system is warranted for two years. If any evaporative emission-related part on your equipment is defective, the part will be repaired or replaced by Country Home Products, Inc.

OWNER'S WARRANTY RESPONSIBILITIES:

As the DR® Field and Finish Mower owner, you are responsible for performance of the required maintenance listed in your owner's manual. Country Home Products, Inc. recommends that you retain all receipts covering maintenance on your DR® Field and Finish Mower, but Country Home Products, Inc. cannot deny warranty solely for the lack of receipts.

As the DR® Field and Finish Mower owner, you should however be aware that Country Home Products, Inc. may deny you warranty coverage if your DR® Field and Finish Mower or a part has failed due to abuse, neglect, or improper maintenance or unapproved modifications.

You are responsible for presenting your DR® Field and Finish Mower to Country Home Products, Inc.'s distribution center or service center as soon as the problem exists. The warranty repairs should be completed in a reasonable amount of time, not to exceed 30 days. If you have a question regarding your warranty coverage, you should contact the Country Home Products, Inc. Technical Service Department by dialing our TOLL-FREE Hotline at 1-800-DR-OWNER (376-9637).

GENERAL EMISSIONS WARRANTY COVERAGE:

Country Home Products, Inc. warrants to the ultimate purchaser and each subsequent purchaser that the DR® Field and Finish Mower is:

- (1) Designed, built and equipped so as to conform with all applicable regulations; and
- (2) Free from defects in materials and workmanship that cause the failure of a warranted part to be identical in all material respects to that part as described in Country Home Products, Inc.'s application for certification.

The warranty period begins on the date the DR® Field and Finish Mower is delivered to an ultimate purchaser. The warranty period is two years.

Subject to certain conditions and exclusions as stated below, the warranty on emission-related parts is as follows:

- (1) Any warranted part that is not scheduled for replacement as required maintenance in the written instructions supplied, is warranted for the warranty period stated above. If the part fails during the period of warranty coverage, the part will be repaired or replaced by Country Home Products, Inc. according to subsection (4) below. Any such part repaired or replaced under warranty will be warranted for the remainder of the period.

(2) Any warranted part that is scheduled only for regular inspection in the written instructions supplied is warranted for the warranty period stated above. Any such part repaired or replaced under warranty will be warranted for the remaining warranty period.

(3) Any warranted part that is scheduled for replacement as required maintenance in the written instructions supplied is warranted for the period of time before the first scheduled replacement date for that part. If the part fails before the first scheduled replacement, the part will be repaired or replaced by Country Home Products, Inc. according to subsection (4) below. Any such part repaired or replaced under warranty will be warranted for the remainder of the period prior to the first scheduled replacement point for the part.

(4) Repair or replacement of any warranted part under the warranty provisions herein must be performed at a warranty station at no charge to the owner.

(5) Notwithstanding the provisions herein, warranty services or repairs will be provided at all of our distribution centers that are franchised to service the subject engines or equipment.

(6) The DR® Field and Finish Mower owner will not be charged for diagnostic labor that is directly associated with diagnosis of a defective, emission-related warranted part, provided that such diagnostic work is performed at a warranty station.

(7) Country Home Products, Inc. is liable for damages to other engine or equipment components proximately caused by a failure under warranty of any warranted part.

(8) Throughout the DR® Field and Finish Mower warranty period stated above, Country Home Products, Inc. will maintain a supply of warranted parts sufficient to meet the expected demand for such parts.

(9) Any replacement part may be used in the performance of any warranty maintenance or repairs and must be provided without charge to the owner. Such use will not reduce the warranty obligations of Country Home Products, Inc.

(10) Add-on or modified parts that are not exempted by the Air Resources Board may not be used. The use of any non-exempted add-on or modified parts by the ultimate purchaser will be grounds for disallowing a warranty claims. Country Home Products, Inc. will not be liable to warrant failures of warranted parts caused by the use of a non-exempted add-on or modified part.

WARRANTED PARTS:

The repair or replacement of any warranted part otherwise eligible for warranty coverage may be excluded from such warranty coverage if COUNTRY HOME PRODUCTS, Inc. demonstrates that the DR® Field and Finish Mower has been abused, neglected, or improperly maintained, and that such abuse, neglect, or improper maintenance was the direct cause of the need for repair or replacement of the part. That notwithstanding, any adjustment of a component that has a factory installed, and properly operating, adjustment limiting device is still eligible for warranty coverage. The following emission warranty parts list are covered (use portions of this list applicable to your DR® Field and Finish Mower:

- (1) Fuel Tank
- (2) Fuel Cap
- (3) Fuel Line
- (4) Fuel Line Fittings
- (5) Fuel Line Clamps
- (7) Control Valve
- (14) Vapor Hoses
- (15) Liquid/Vapor Separator
- (16) Carbon Canister
- (17) Canister Mounting Brackets
- (18) Carburetor Purge Port Connector

If you have any questions, please contact us at www.DRpower.com or call 1-800-DR-OWNER (376-9637)

Daily Checklist for the TOW-BEHIND DR FIELD and FINISH MOWER

WARNING

When performing any adjustment or maintenance, you must first shut off the engine, wait five minutes to allow parts to cool and disconnect the spark plug wire, keeping it away from the spark plug.

To help maintain your **TOW-BEHIND DR FIELD and FINISH MOWER** for optimum performance, we recommend you follow this checklist each time you use your machine.

- [] Check the engine oil and Gas Tank level.
- [] Check that Engine is clean of debris.
- [] Check the general condition of the Mower, e.g.; nuts, bolts, welds, etc.
- [] Check Tire Pressure and wear.
- [] Check the Frame for wear and damage.
- [] Check the Blades and Spindle for tightness, nicks, cracks, wear or debris that has wrapped around.

End of Season and Storage

WARNING

When performing any adjustment or maintenance, you must first shut off the engine, wait five minutes to allow parts to cool and disconnect the spark plug wire, keeping it away from the spark plug.

Note: Please refer to the Engine Owner's Manual for Engine-specific procedures.

- Change the Engine Oil and Oil Filter (Mow Pro-60) and replace the Fuel Filter.
- Remove the Spark Plug and pour about 1 ounce of motor oil into the Cylinder hole. Replace the Plug and crank the Engine over a couple of times using the Starter Pull Cord or the Electric Starter (Mow Pro-60). This will coat the pistons and seat the valves to prevent moisture buildup.
- Clean or replace the Air Filter(s).
- Clean dirt and debris from the Cylinder Head Cooling Fins, Blower Housing, Debris Screen, and Muffler area of the Engine.
- If your TOW-BEHIND DR FIELD and FINISH MOWER will be idle for more than 30 days, we recommend using a gas stabilizer. This will prevent sediment from gumming up the Carburetor. If there is dirt or moisture in the gas or tank, remove it by draining the tank. Completely fill the tank with fresh, unleaded gas and add the appropriate amount of stabilizer or gasoline additive. Run the Engine for a short time to allow the additive to circulate.
- Remove any wrapped weeds from the Blades Carrier Housing. Clean grass and debris from the top and underneath the mower Deck with a stiff brush.
- Check the Blades for nicks and wear. Remove the Blades and sharpen them, or have them professionally sharpened if needed.
- Touch-up all rusted or chipped paint surfaces. Sand them lightly before painting.
- Be sure all nuts, bolts, and screws are securely fastened.
- Inspect moving parts and the Blades' Drive Belt for damage and wear; replace if necessary.
- Store the Battery in a dry area that will not freeze. If you will not use the machine over a long period, charge the Battery every four to six weeks.
- If possible, store your TOW-BEHIND DR FIELD and FINISH MOWER inside, but not near an open flame or spark such as found in a water heater.
- After the TOW-BEHIND DR FIELD and FINISH MOWER has cooled, cover the machine with a suitable protective cover that does not retain moisture. Do not use plastic, as this material cannot breathe; it also allows condensation to form, which will cause your machine to rust.



75 MEIGS ROAD, P.O. BOX 25, VERGENNES, VERMONT 05491