

TOW-BEHIND DR[®] FIELD and BRUSH MOWER

SAFETY & OPERATING INSTRUCTIONS

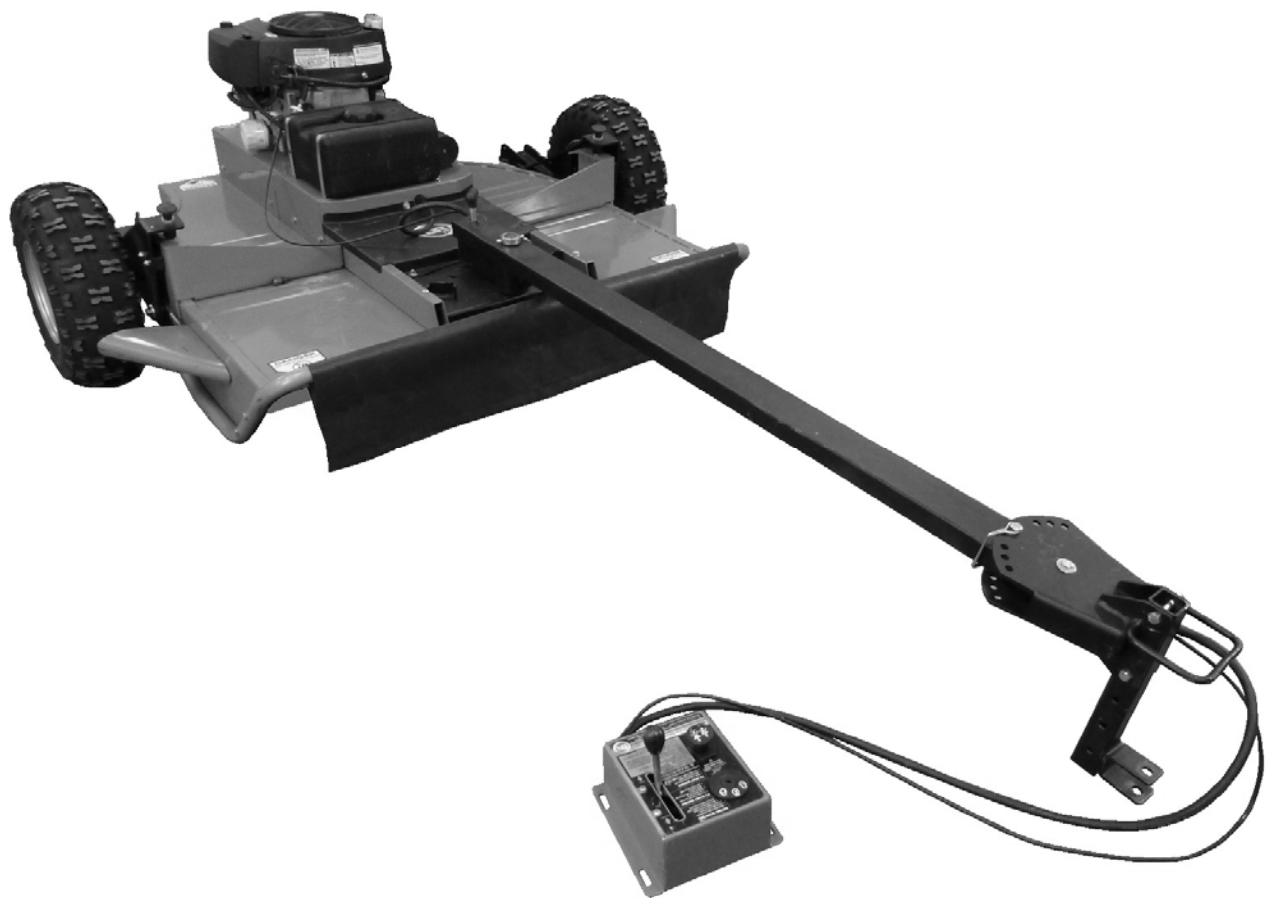

Serial No. _____

Order No. _____

Original Language

DR Power Equipment
Toll-free phone: 1-800-DR-OWNER (376-9637)
Fax: 1-802-877-1213
Website: www.DRpower.com

! WARNING

Read and understand this manual and all instructions before operating the TOW BEHIND DR FIELD and BRUSH MOWER.

Table of Contents

Chapter 1: General Safety Rules.....	3
Chapter 2: Setting Up The TOW-BEHIND DR FIELD and BRUSH MOWER.....	7
Chapter 3: Operating The TOW-BEHIND DR FIELD and BRUSH MOWER.....	17
Chapter 4: Maintaining The TOW-BEHIND DR FIELD and BRUSH MOWER	23
Chapter 5: Troubleshooting	29
Chapter 6: Parts Lists and Schematic Diagrams.....	31

Conventions used in this manual

WARNING

This indicates a hazardous situation, which, if not avoided, could result in death or serious injury.

CAUTION

This indicates a hazardous situation, which, if not avoided, could result in minor or moderate injury.

NOTICE

This information is important in the proper use of your machine. Failure to follow this instruction could result in damage to your machine or property.

Serial Number and Order Number

A Serial Number is used to identify your machine and is located on the Serial Number Label on your machine. An Order Number is used to check and maintain your order history and is located on the upper left portion of your packing slip. For your convenience and ready reference, enter the Serial Number and Order Number in the space provided on the front cover of this manual.

Additional Information and Potential Changes

DR Power Equipment reserves the right to discontinue, change, and improve its products at any time without notice or obligation to the purchaser. The descriptions and specifications contained in this manual were in effect at printing. Equipment described within this manual may be optional. Some illustrations may not be applicable to your machine.

Chapter 1: General Safety Rules

⚠ WARNING

Read this Safety & Operating Instructions manual before you use the TOW BEHIND DR FIELD and BRUSH MOWER. Become familiar with the operation and service recommendations to ensure the best performance from your machine. If you have any questions or need assistance, please contact us at www.DRpower.com or call toll-free 1-800-DR-OWNER (376-9637) and one of our Technical Support Representatives will be happy to help you.

Labels

Your TOW BEHIND DR FIELD and BRUSH MOWER carries prominent labels as reminders for its proper and safe use. Shown below are copies of all the Safety and Information labels that appear on the equipment. Take a moment to study them and make a note of their location on your Mower as you set up and before you operate the unit. Replace damaged or missing safety and information labels immediately.



#136491



#136831

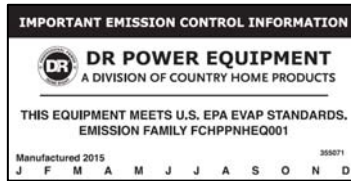

#35507
(Pro and Pro-XL Models)



#137581

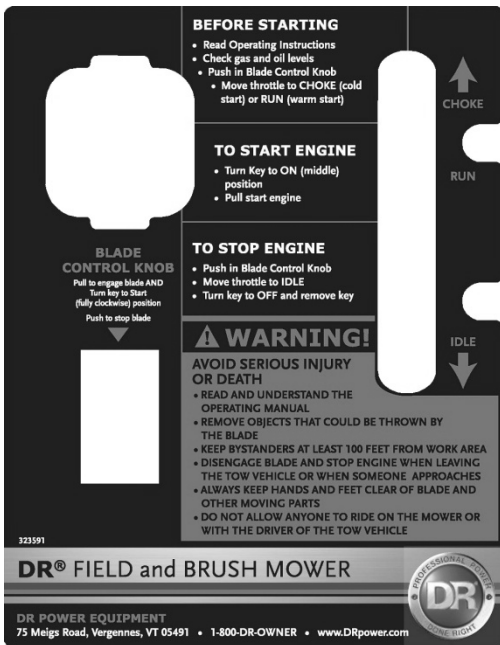

#32359
(Premier Model)



#22222
(Pro and Pro-XL Models)

Protecting Yourself and Those Around You

WARNING

This is a high-powered machine with fast moving parts operating at high speeds. You must operate this machine safely. Unsafe operation can create hazards for you, as well as anyone else in the work area. Use proper clothing and safety gear when operating this machine to prevent or minimize the risk of severe injury. Always take the following precautions when operating the TOW-BEHIND DR FIELD and BRUSH MOWER:

- Always wear protective goggles or safety glasses with side shields while mowing to protect your eyes from possible objects thrown from the machine.
- We recommend wearing safety shoes when using this machine. Wear shoes with non-slip treads to improve footing on slippery surfaces. Do not use the machine wearing open sandals or while barefoot.
- We recommend wearing long pants and gloves while using this machine. Be sure the gloves fit properly and do not have loose cuffs or drawstrings.
- We recommend the use of ear protectors or ear plugs rated for at least 20 dba to protect your hearing.
- Allow only responsible individuals who are familiar with these general safety rules and operating instructions to use your TOW-BEHIND DR FIELD and BRUSH MOWER. Never allow people who are unfamiliar with these rules and instructions to use your machine.
- Have a complete working knowledge of your tow vehicle and know how to handle it with the TOW-BEHIND DR FIELD and BRUSH MOWER attached.
- Keep your hands and feet away from the blades, belt, blade pulley, and concealed areas while the engine is running. Never reach under the deck or grab hold of any part of the deck when the engine is running.
- The mower can throw objects far and at great speeds. Keep people and pets at least 100 feet away from your machine at all times. Install warnings around the area of operation stating “It is prohibited to enter this area”. Disengage the blade and stop the engine when a person or pet approaches within 100 feet. Do not restart the machine until people and pets are at least 100 feet away from the mower.
- Clear the area of objects such as rocks, toys, wire, bones, sticks, etc., which could be picked up and thrown by the blades.
- Be sure the blade control knob is down (disengaged) before attempting to start the engine.
- Never get off the tow vehicle without first stopping the blades and shutting off the tow vehicle engine and the TOW-BEHIND DR FIELD and BRUSH MOWER engine.
- Never, under any conditions, remove, bend, cut, fit, weld, or otherwise alter standard parts on the TOW-BEHIND DR FIELD and BRUSH MOWER. This includes all shields and guards. Modifications to your machine could cause personal injuries and property damage and will void your warranty.

Safety for Children and Pets

WARNING

Tragic accidents can occur if the operator is not alert to the presence of children and pets. Children are often attracted to the machine and the digging activity. *Never* assume that children will remain where you last saw them. Always follow these precautions:

- Keep children and pets at least 100 feet from the working area and ensure they are under the watchful care of a responsible adult.
- Be alert and always turn off your tow vehicle engine and the Tow-Behind DR Field & Brush Mower engine if children enter the work area.
- Before, and while moving your tow vehicle backwards, look behind, and down for small children.
- Never allow children to operate the TOW-BEHIND DR FIELD and BRUSH MOWER.
- Never allow children to ride on the mower, even if the engine is not running.
- Use extra care when approaching blind corners, shrubs, trees, or other objects that may obscure your vision.

Slope Operation

WARNING

- Use of machinery on slopes is a major factor related to accidents, which can result in severe personal injury. Use of machinery on slopes requires caution. If you feel uneasy using the TOW-BEHIND DR FIELD and BRUSH MOWER on a slope, do not operate it. Always take the following precautions when using this machine on slopes:

ALWAYS:

- Operate the machine up and down the face of slopes and avoid going across. Exercise extreme caution when changing direction on slopes.
- Remove objects such as glass, large sticks, stones, metal objects, wire, rope, and string-like material.
- Watch for holes, ruts, and bumps on the ground.

NEVER:

- Never operate near drop-offs, ditches, or embankments; you could lose control of your tow vehicle and/or the TOW-BEHIND DR FIELD and BRUSH MOWER.
- Never operate on slopes greater than 20 degrees, or on any excessively steep slope. See the operating parameters section on page 21 for further restrictions relating to your tow vehicle.
- Never operate on wet, or slippery slopes. Reduced traction could result in tipping over your tow vehicle and/or the TOW-BEHIND DR FIELD and BRUSH MOWER.
- Never park the tow vehicle on a steep grade or slope.

Safety with Gasoline - Powered Machines

WARNING

Gasoline is a highly flammable liquid. Gasoline also gives off flammable vapor that can be easily ignited and cause a fire or explosion. Never overlook the hazards of gasoline. Always follow these precautions:

- Never run the engine in an enclosed area or without proper ventilation as the exhaust from the engine contains carbon monoxide, which is an odorless, tasteless, and deadly poisonous gas.
- Store all fuel and oil in containers specifically designed and approved for this purpose and keep away from heat and open flame, and out of the reach of children.
- Replace rubber fuel lines and grommets when worn or damaged and after 5 years of use.
- Fill the gasoline tank outdoors with the engine off and allow the engine to cool completely. Don't handle gasoline if you or anyone nearby is smoking, or if you're near anything that could cause it to ignite or explode. Reinstall the fuel tank Cap and fuel container cap securely.
- If you spill gasoline, do not attempt to start the engine. Move the machine away from the area of the spill and avoid creating any source of ignition until the gas vapors have dissipated. Wipe up any spilled fuel to prevent a fire hazard and properly dispose of the waste.
- Allow the engine to cool completely before storing in any enclosure. Never store a machine that has gas in the tank, or a fuel container, near an open flame or spark such as a water heater, space heater, clothes dryer or furnace.
- Never make adjustments or repairs with the engine running. Shut down the engine, disconnect the spark plug wire, keeping it away from the spark plug to prevent accidental starting, wait 5 minutes before making adjustments or repairs.
- Never check for an ignition spark with the spark plug or spark plug wire(s) removed. Always use an approved spark tester.
- Never tamper with safety devices. Regularly check their proper operation.
- Never change the engine governor settings or modify the engine speed. Modifications will void your warranty.
- To reduce fire hazard, keep the engine and muffler area free of debris build-up such as leaves, grass, oil, grease, or any other combustible material. Clean the engine area after each use.
- Never operate the engine without the muffler. Inspect the muffler periodically and replace if necessary. If the engine is equipped with a muffler deflector, inspect it periodically and replace if necessary.
- Never cover the machine while the muffler is still hot.
- Do not operate the engine with the air cleaner or the carburetor air intake cover removed. Removal of such parts could create a fire hazard. Do not use flammable solutions to clean the air filter.
- The muffler and engine become very hot and can cause a severe burn; do not touch.

General Safety

WARNING

Safe operation of the TOW-BEHIND DR FIELD and BRUSH MOWER is necessary to prevent or minimize the risk of death or serious injury. Unsafe operation can create a number of hazards for you. Always take the following precautions when operating this machine:

- The TOW-BEHIND DR FIELD and BRUSH MOWER is a powerful tool and not a plaything. When using this machine, exercise extreme caution at all times. The design of this machine is to mow grass and brush. Do not use it for any other purpose.
- The operator or user of the TOW-BEHIND DR FIELD and BRUSH MOWER is responsible for accidents or hazards occurring to other people, their property, and themselves.
- Always mount the remote control panel within easy reach of the operator's position.
- Know how to quickly stop the TOW-BEHIND DR FIELD and BRUSH MOWER. See page 15.
- Never allow people or pets to ride on this machine, even with the engine turned off.
- If the machine should make an unusual noise or vibration, shut off the tow vehicle and the TOW-BEHIND DR FIELD and BRUSH MOWER engines. Vibration is generally a warning of trouble. Wait five (5) minutes for the TOW-BEHIND DR FIELD and BRUSH MOWER engine to cool. Disconnect the spark plug wire(s) and then inspect the machine for clogging, or loose engine mounting bolts. Clear any obstructions and repair and/or replace damaged parts.
- The mower blades are sharp and can cut. Wrap the blades or wear gloves, and use extra caution when servicing.
- Always keep the machine in good safe operating condition. Always make certain nuts and bolts are tight and always use the supplied self-locking hardware. Do not use substitute hardware.
- Always shut off the tow vehicle engine TOW-BEHIND DR FIELD and BRUSH MOWER engine, wait five (5) minutes to cool, and disconnect the spark plug wire(s) before attempting to remove grass or debris from the underside of the deck.
- Use the TOW-BEHIND DR FIELD and BRUSH MOWER only in daylight and give complete and undivided attention to the job at hand.
- Do not hurry or take things for granted when using the TOW-BEHIND DR FIELD and BRUSH MOWER. When in doubt about the machine or your surroundings, stop the mowing activity and take time to look things over.
- Disengage the blades and exercise extreme caution when on or crossing drives, walks, or roads. Stay alert for hidden hazards or traffic.
- If leaving the machine, shift the tow vehicle into neutral and set the parking brake; turn off the tow vehicle engine and remove its key; turn off the TOW-BEHIND DR FIELD and BRUSH MOWER engine and remove its key.
- Do not operate the mower when under the influence of alcohol, drugs, or medication.

A Note to All Users

Under California law, and the laws of some other states, you are not permitted to operate an internal combustion engine using hydrocarbon fuels without an engine spark arrester. This also applies to operation on US Forest Lands. All TOW-BEHIND DR[®] FIELD and BRUSH MOWERS shipped to California, New Mexico and Washington State are provided with spark arresters. Failure of the owner or operator to maintain this equipment in compliance with state regulations is a misdemeanor under California law and may be in violation of other state and/or federal regulations. Contact your State Park Association or the appropriate state organization for specific information in your area.

No list of warnings and cautions can be all-inclusive. If situations occur that are not covered by this manual, the operator must apply common sense and operate this TOW-BEHIND DR FIELD and BRUSH MOWER in a safe manner. Contact us at www.DRpower.com or call 1-800-DR-OWNER (376-9637) for assistance.

Chapter 2: Setting Up The TOW-BEHIND DR FIELD and BRUSH MOWER

It may be helpful to familiarize yourself with the controls and features of your TOW-BEHIND DR FIELD and BRUSH MOWER by reviewing **Figure 1** before beginning these procedures. If you have any questions at all, please feel free to contact us at www.DRpower.com.

TOW-BEHIND DR FIELD and BRUSH MOWER Controls and Features (Premier model)

NOTE: The model shown in Figure 1 may look slightly different from your machine.

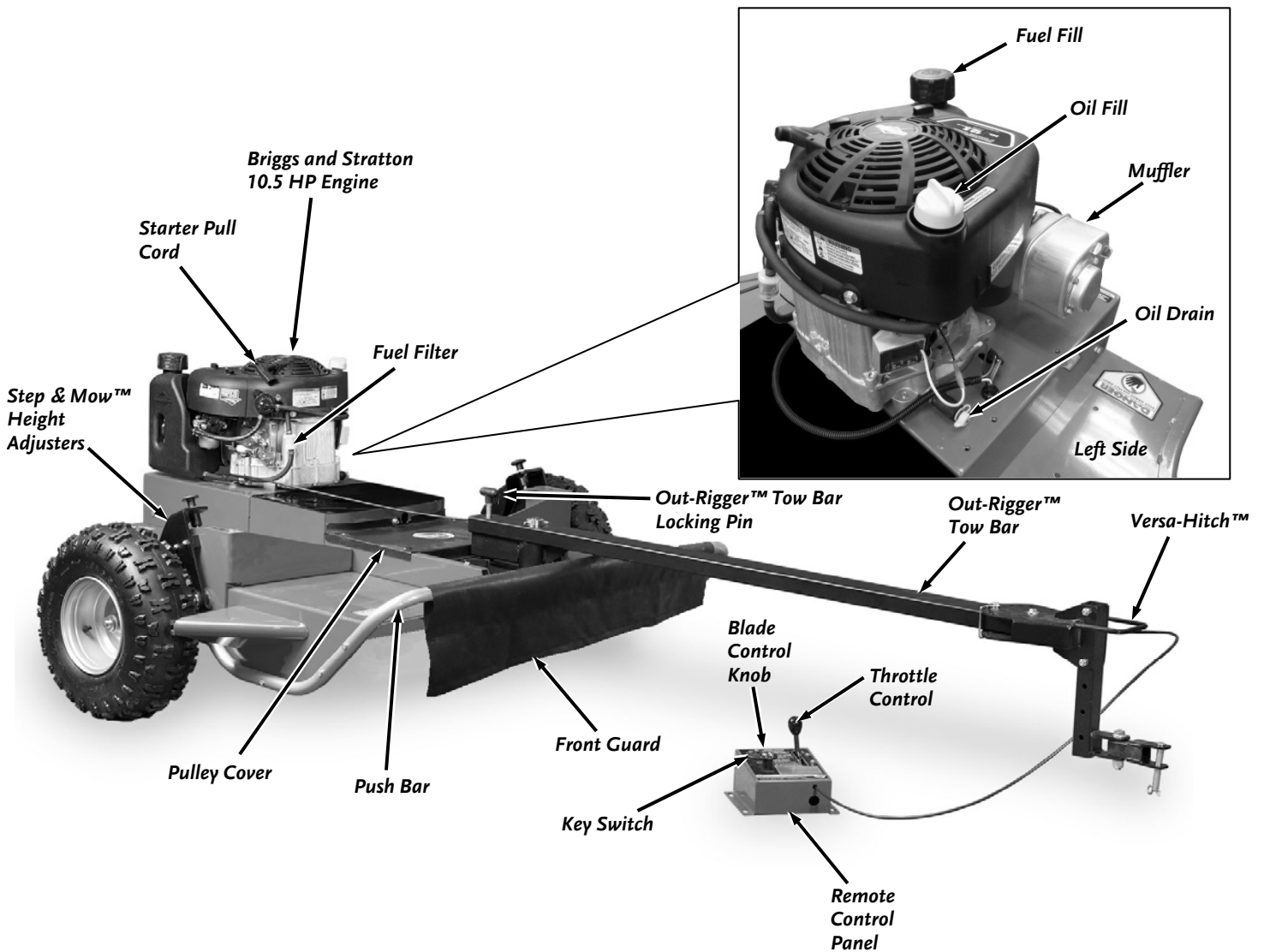

Figure 1a

TOW-BEHIND DR FIELD and BRUSH MOWER Controls and Features (Pro and Pro-XL Models)

NOTE: The model shown in Figure 1 may look slightly different from your machine.

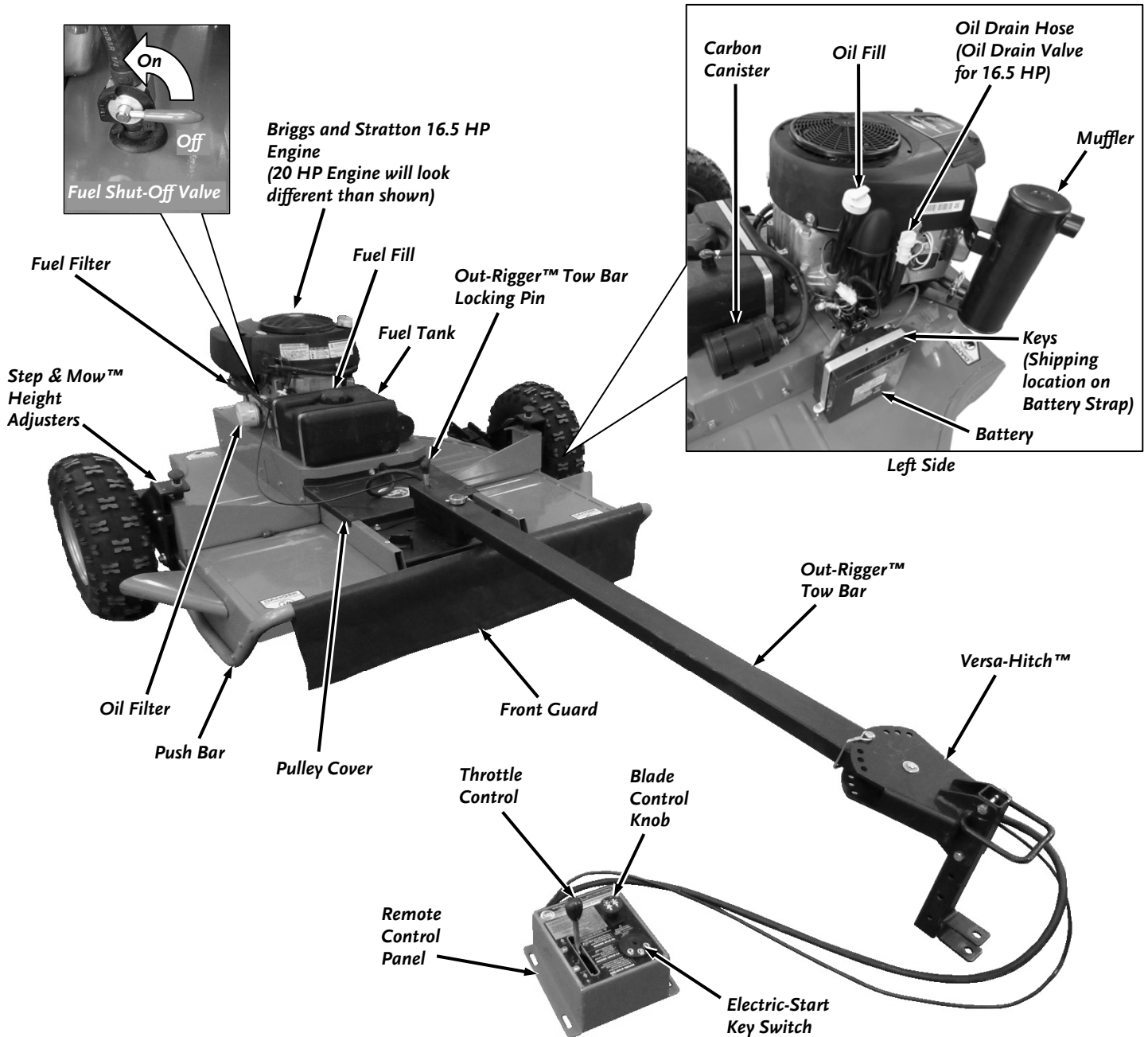

Figure 1b

Specifications

	10.5 HP Premier Model	16.5 HP Pro Model	20 HP Pro-XL Model
Engine	See your Engine Manual for Oil capacity and other Engine specifications.	See your Engine Manual for Oil capacity and other Engine specifications.	See your Engine Manual for Oil capacity and other Engine specifications.
Starting System	Manual Start	Electric Start	Electric Start
Fuel Tank	.75 Gal. (2.84 L), Gasoline, Unleaded	2.5 Gal. (9.46 L), Gasoline, Unleaded	2.5 Gal. (9.46 L), Gasoline, Unleaded
Wheels	18" Dia. x 6-7/8" Wide, All Terrain Tread, 28 PSI, Sealed, Tubeless	18" Dia. x 6-7/8" Wide, All Terrain Tread, 28 PSI, Sealed, Tubeless	18" Dia. x 6-7/8" Wide, All Terrain Tread, 28 PSI, Sealed, Tubeless
Remote Control Panel	Key Switch, Throttle Lever, and Blade Engage Switch, 5' from Versa-Hitch™ to front of Control Panel.	Key Switch, Throttle Lever, and Blade Engage Switch, 5' from Versa-Hitch™ to front of Control Panel.	Key Switch, Throttle Lever, and Blade Engage Switch, 5' from Versa-Hitch™ to front of Control Panel.
Deck Offset	0%, 50%, 75%, 100% Out-Rigger™ Tow Bar	0%, 50%, 75%, 100% Out-Rigger™ Tow Bar	0%, 50%, 75%, 100% Out-Rigger™ Tow Bar
Adjustable Cutting Height	4", 5", 6-1/4" and 7-1/2". Step & Mow™ Wheel Axle and Versa-Hitch™	5", 6-1/4", and 7-1/2" Step & Mow™ Wheel Axle and Versa-Hitch™	5", 6-1/4", and 7-1/2" Step & Mow™ Wheel Axle and Versa-Hitch™
Cutting Width	44"	44"	44"
Cutting Capacity	4' High Grass, 8'-high weeds & brush, 1" Thick Saplings	4' High Grass, 8'-high weeds & brush, 1-1/2" Thick Saplings	6' High Grass, 8'-high weeds & brush, 2" Thick Saplings
Blade Tip Speed	195 MPH or 17,180 Ft/Min	195 MPH or 17,180 Ft/Min	195 MPH or 17,180 Ft/Min
Swinging Blades	"PRO-TEK" Swinging Blades 2 Blades, .25" Thick x 16-1/2" Long, Hardened Steel	"PRO-TEK" Swinging Blades 2 Blades, .25" Thick x 16-1/2" Long, Hardened Steel	"PRO-TEK" Swinging Blades 2 Blades, .25" Thick x 16-1/2" Long, Hardened Steel
Deck	11 GA (.12" thick) Welded Steel	11 GA (.12" thick) Welded Steel	11 GA (.12" thick) Welded Steel
Spindle	1-3/8" Dia. Shaft with 2 Sealed 30 mm Bearings	1-3/8" Dia. Shaft with 2 Sealed 30 mm Bearings	1-3/8" Dia. Shaft with 2 Sealed 30 mm Bearings
Spindle Housing	7 GA (.18" thick) Welded Steel	7 GA (.18" thick) Welded Steel	7 GA (.18" thick) Welded Steel
Push Bar	1-1/4" Dia. x 11 GA (.12" thick) Steel Tubing	1-1/4" Dia. x 11 GA (.12" thick) Steel Tubing	1-1/4" Dia. x 11 GA (.12" thick) Steel Tubing
Front Guard	3/16" Thick Compressed Rubber	3/16" Thick Compressed Rubber	3/16" Thick Compressed Rubber
Belt	5/8" x 53.8" Type BP51	5/8" x 53.8" Type BP51	5/8" x 53.8" Type BP51
Electric Clutch	75 ft-lb Ogura	75 ft-lb Ogura	95 ft-lb Ogura
Fuses	None	20 AMP Type AGC Fuse (Engine Alternator Circuit) 7 AMP Type AGC Fuse (Clutch Circuit)	20 AMP Type AGC Fuse (Engine Alternator Circuit) 7 AMP Type AGC Fuse (Clutch Circuit)
Machine Overall Width	64-1/4" Outside the Wheels	64-1/4" Outside the Wheels	64-1/4" Outside the Wheels
Machine Overall Length	110" with the Tow Bar fully extended	110" with the Tow Bar fully extended	110" with the Tow Bar fully extended
Machine Overall Height	28-1/2"	28-1/4"	28-7/8"
Machine Weight at Tow Bar	32 lbs.	35 lbs.	27 lbs.
Machine Weight	420 lbs.	456 lbs.	468 lbs.
Shipping Weight	595 lbs.	617 lbs.	629 lbs.
Shipping Crate	73" x 60" x 36"	73" x 60" x 36"	73" x 60" x 36"

Unpacking and Assembling the Machine

Unpacking and assembling the TOW-BEHIND DR FIELD and BRUSH MOWER is a two-person job as the 10.5 HP unit weighs 420 pounds, 15 HP unit weighs 442 pounds and the 20 HP unit weighs 485 pounds. We recommend you have an extra set of hands available before you begin. Electric Start models have the Key located on the rear of the Battery Strap as shown in Figure 1 on page 7.

Parts Supplied in Crate:

- TOW-BEHIND DR FIELD and BRUSH MOWER
- Safety & Operating Instructions Manual
- Engine Manual
- Small Parts Bag:
 - Hook and Loop Straps - Plastic hose (oil drain)
 - Extra Cable Ties

Tools and Supplies Needed:

- Pry Bar
- Metal Shears
- Hammer
- Gloves and Eye Protection

⚠ CAUTION

- Stabilize the shipping container on clean flat terrain before attempting to unpack and assemble the machine.
- Always wear eye protection and stand to one side when cutting the banding. The banding is under a lot of tension and can cause injury when you release the tension.
- Use caution around exposed nails when uncrating the machine.

1. Pry off and remove the top cross members of the shipping crate. **Be careful of the nails when removing the boards.**
2. Pry off and remove the crate sides; the two (2) long sides first, and then the two (2) short sides.
3. Stand to one side and cut any bands holding the machine to the shipping pallet and the bands holding the Remote Control Panel carton to the Push Bar. **Be careful when cutting the banding.**
4. The Out-Rigger™ Tow Bar is shipped unassembled; remove it from the pallet.
5. Raise the Mower Deck Height to the highest setting (7-1/2") to clear the blocking beneath the back of the machine (see page 20 for adjustment instructions) and then roll the Mower off the shipping pallet.

⚠ CAUTION

Wear gloves and be very careful when handling the deck. The blades are very sharp, and may spin as you maneuver the deck.

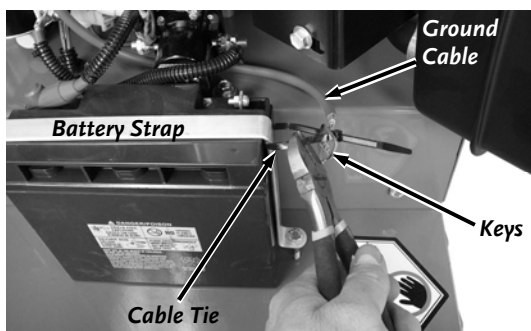

Figure 2

6. Remove the Blade Protector from the Blades. (See **CAUTION** note above)
7. **Pro and Pro-XL Models:** Cut the Cable Tie that is securing the Keys and Ground Cable to the Battery Strap (**Figure 2**).
- Premier Model:** Cut the Cable Tie that is securing the Keys to the control panel.
8. Do not discard your pallet and packaging material until you are fully satisfied with your new TOW-BEHIND DR FIELD and BRUSH MOWER.

About the Battery

The Pro and Pro-XL TOW-BEHIND DR FIELD and BRUSH MOWERS come with a 12-Volt, maintenance-free, rechargeable, sealed lead acid Battery. Properly maintained and charged, the Battery provides years of dependable service.

! WARNING

- Never modify the TOW-BEHIND DR FIELD and BRUSH MOWER'S electrical system. Modifications could ruin the electrical system as well as cause a fire, resulting in serious injury.
- Using electrical components other than those supplied with your machine could cause the electrical system to overheat, explode, or start a fire.
- Using the wrong type of battery or charger could cause a fire or explosion, resulting in serious injury.
- Use the charger only in dry locations. Avoid contact with water.
- Only adults should handle the battery. It contains sulfuric acid (an electrolyte) and the battery is heavy; dropping it could result in serious injury.
- Never allow children to charge the battery. THE ELECTRICITY INVOLVED IN CHARGING THE BATTERY COULD CAUSE SEVERE INJURY.
- Examine the charger, its connectors, and the battery for excessive wear or damage each time you charge the battery. Replace any components showing excessive wear or damage.
- Never lift or carry the battery by the cables or terminals. This can damage the battery and possibly start a fire, resulting in serious injury. Lift and carry the battery only by its case.
- Do not short circuit the battery.
- Read the safety instructions on the battery.

Connecting the Battery Wire (Pro and Pro-XL models)

We ship all Electric-Starting machines with the negative (ground) Battery Wire disconnected. This prevents the Battery from discharging during shipment. Before using your TOW-BEHIND DR FIELD and BRUSH MOWER, you must connect the negative (ground) Battery Wire.

Tools Needed:

- Two 5/16" Wrenches
- Cutting Pliers

! WARNING

When attaching the Negative (ground) Wire, make sure you position and attach the Wire so that it will not rest on or near the Muffler. The heat from the Muffler will melt the coating and create a fire hazard causing harm to the machine and/or yourself.

1. Connect the Green negative wire to the negative terminal on the Battery with two 5/16" Wrenches (**Figure 3**).

NOTE: The Bolt and Nut come with the Battery.

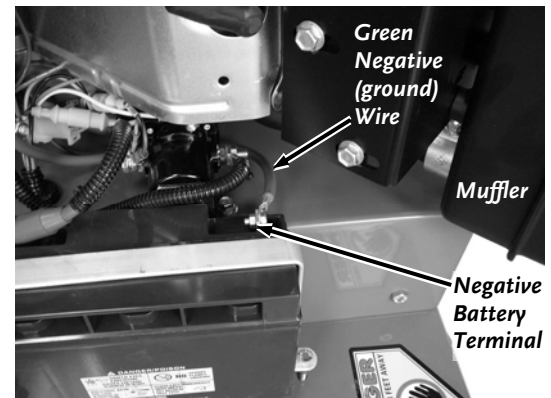

Figure 3

Adding Oil and Gasoline

NOTICE

- You must add oil before starting the engine. This machine is shipped without oil. Traces of oil may be in the reservoir from factory testing, but **YOU MUST ADD OIL BEFORE STARTING THE ENGINE**. Fill the reservoir slowly, checking the level frequently to avoid overfilling.
- To get an accurate reading when checking the oil level:
 - The machine should be on a level surface.
 - The dipstick **SHOULD** be screwed down.

Tip: To avoid confusion, we recommend leaving the caps ON the Fuel and Oil Fills until you are ready to pour either gasoline or oil into the correct Fill.

Note: Use only SAE 30 HD (High Detergent) oil. Other types of oil could cause problems with the operation of your machine. Please refer to your Engine Owner's Manual for detailed oil information.

Engine Oil and Fuel Capacities		
	Oil (SAE 30 HD)	Fuel (Unleaded)
Briggs and Stratton – 10.5 HP	See your Engine Manual for Oil capacities.	See your Engine Manual for Fuel capacity.
Briggs and Stratton – 16.5 HP		2.5 Gal (9.46 L)
Briggs and Stratton – 20 HP		2.5 Gal (9.46 L)

1. Place the machine on a level surface and initially add 32 oz. of SAE 30 High Detergent oil (recommended by the Engine Manufacturer) into the Oil Fill (**Figure 4**) and wait one minute for the oil to settle.
2. Check the Dipstick and continue adding a few ounces of oil at a time, rechecking the Dipstick until the oil reaches the fill mark. Be careful not to overfill.
3. Fill the gas tank to within 1-1/2 inches below top of fill neck (to allow for fuel expansion) with fresh, unleaded gas. See the Engine Owner's Manual for more information.



Briggs and Stratton 10.5 HP Engine

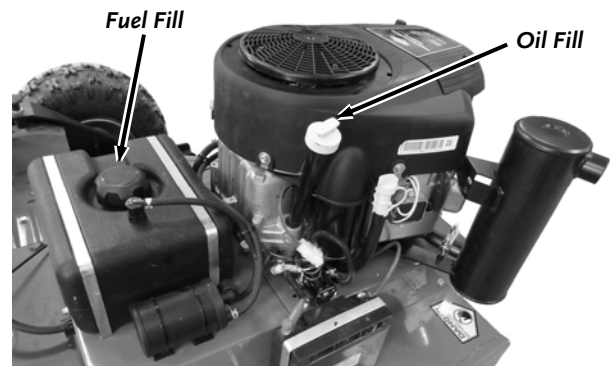

Briggs and Stratton 20 HP Engine (16.5 HP similar)

Figure 4

Attaching the Out-Rigger™ Tow Bar to the TOW-BEHIND DR FIELD and BRUSH MOWER

⚠ WARNING

When attaching the tow bar and wire harnesses, you must first disconnect the spark plug wire(s), keeping it away from the spark plug(s) to prevent accidental starting of the engine.

Tools Needed:

- 3/8" Wrench

1. Using a 3/8" Wrench or Socket, remove the three (3) Bolts and Washers that retain the black Pulley Cover and remove the Cover (**Figure 5**).
2. Locate and remove the Tow Bar Retaining Pin and Collar from the Pivot Pin on the front of the Mower Deck.
3. Pull the Handle of the Tow Bar Locking Pin up so its Spring Pins are above the Tow Bar and then twist the Handle 90° so the bottom Spring Pin rests on top of the Tow Bar (**Figure 6**).

Tip: Enlist the help of another person to hold the Tow Bar level during the next step.

4. Place the Tow Bar over the Pivot Pin and install the Collar and the Tow Bar Retaining Pin.

NOTE: The Remote Control Panel Throttle Cable and Wire Harness are routed inside the Tow Bar housing. Use care not to pinch them when attaching the Tow Bar over the Pivot Pin.

5. Pull the Tow Bar Locking Pin Handle up, turn it 90°, and release the Locking Pin into the center hole in the Tow Bar Mount Plate.

Connecting the Remote Control Panel Throttle Cable and Control Wire Harness

Note: An optional Control Extension Kit is available to give you more mounting options for your machine. You can replace the existing Throttle Cable with a longer one and extend the existing Wire Harness. Visit our website at www.DRpower.com to order Kit #23388 for the 10.5 HP and 16.5 HP Engines and order Kit #23390 for the 20 HP Engines.

Control Wire Harness

1. Locate the Solenoid Wire Harness with Terminals under the orange Fuel Tank Mount (**Figure 7**).
2. Connect the terminals of the Solenoid Wire Harness to the terminals of the Control Wire Harness coming from the Tow Bar (they are keyed and color coded) by pushing them together until they snap in place.
3. Position the Strain-Relief behind the cutout in the Fuel Tank Mount and then pull it towards you into the cutout until it snaps in place. Make sure the Wire Harness terminals are tucked back under the Fuel Tank Mount.
4. Replace the black Belt Cover and secure with the three Bolts and Washers.

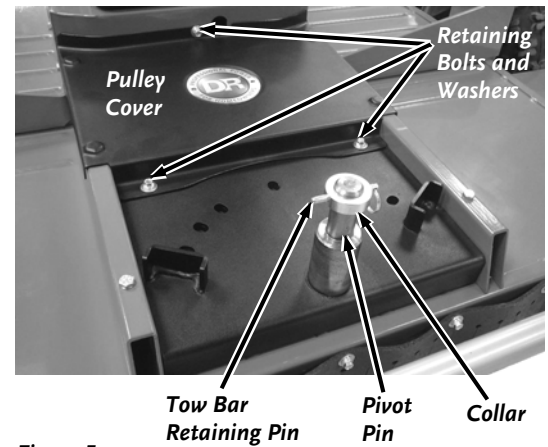

Figure 5

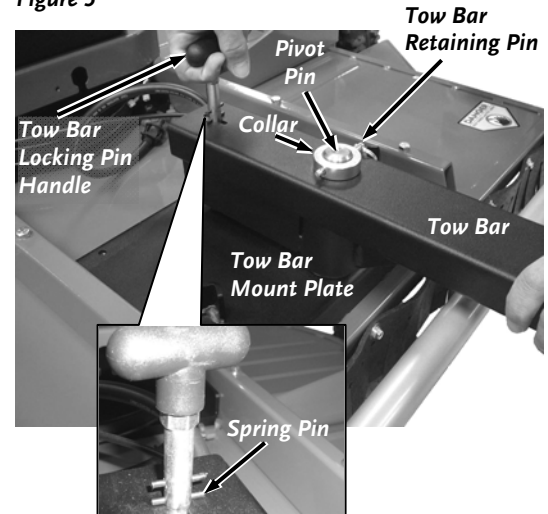

Figure 6

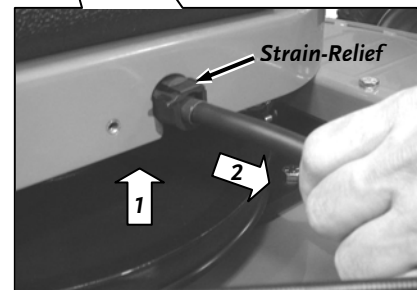
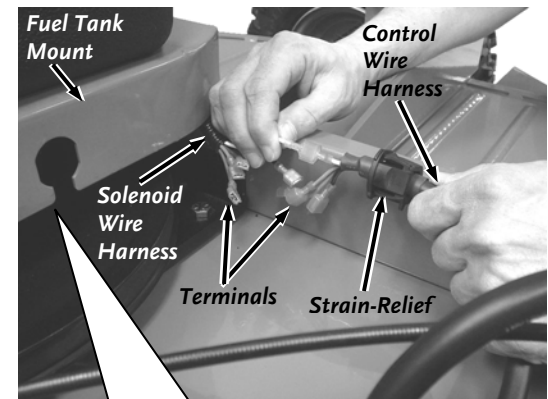

Figure 7



Figure 8

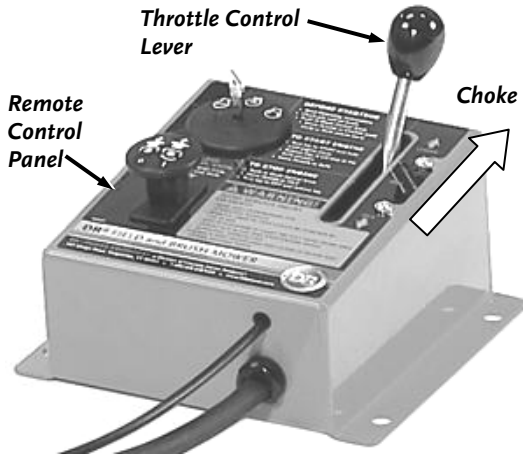

Figure 9

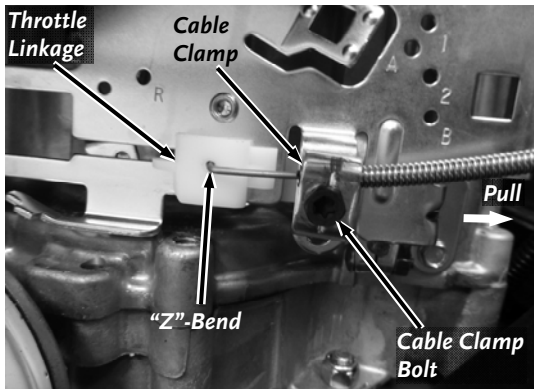

Figure 10

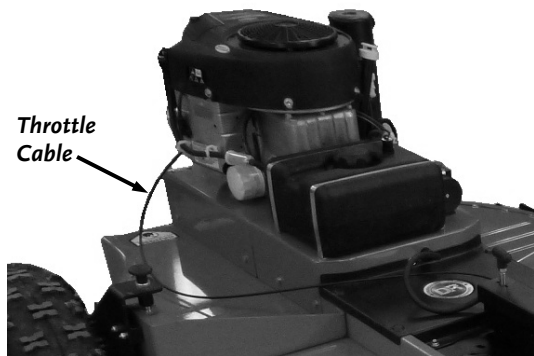

Figure 11

Throttle Cable – Premier 10.5 HP and 16.5 HP Briggs and Stratton

Tools Needed:

- T25 Torx Bit
1. Route the Throttle Control Cable from the Tow Bar up to the Throttle Linkage on the right hand side of the Engine (**Figure 8**).
 2. Move the Throttle Control to the Choke position on the Remote Control Panel (**Figure 9**).
 3. Insert the “Z”-Bend of the Cable end into the hole in the Throttle Linkage on the side of the Engine (**Figure 10**).
 4. Using a T25 Torx Bit, loosen the Throttle Cable Clamp Bolt, and slip the Cable Sheath behind the Clamp.
 5. Pull the Cable Sheath as far as possible towards the front of the machine. This will move the Linkage into the Choke position.
 6. Tighten the Cable Clamp Bolt while holding the Cable in the Choke position.

Throttle Cable – Pro-XL 20 HP Briggs and Stratton

Tools Needed:

- T25 Torx Bit
1. Route the Throttle Control Cable from the Tow Bar up the left hand side of the Engine to the Throttle Linkage at the back of the Engine (**Figure 11**).
 2. Move the Throttle Control to the Choke position on the Remote Control Panel (**Figure 12**).

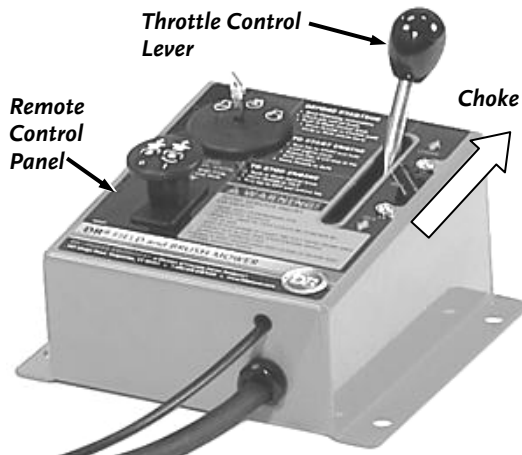

Figure 12

3. Insert the "Z"-Bend of the Cable end into the bottom hole in the Throttle Pivot linkage on the back of the Engine (**Figure 13**).
4. Using a T25 Torx Bit, loosen the Throttle Cable Clamp Bolt, and slip the Cable Sheath behind the Clamp.
5. Pull the Cable Sheath as far as possible towards the right side of the machine. This will move the Pivot Arm into the Choke position.
6. Tighten the Cable Clamp Bolt while holding the Cable in the Choke position.
7. Install one end of the Throttle Return Spring to the Throttle Linkage Bracket and the other end to the "Z" Bend at the end of the Throttle Cable (**Figure 13a**).

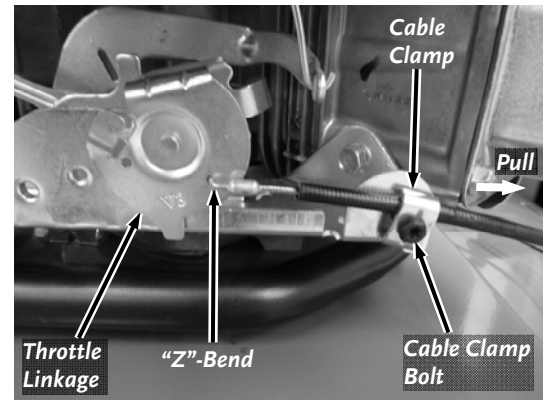

Figure 13

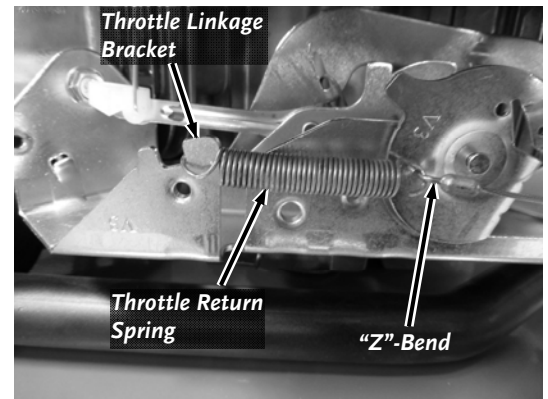

Figure 13a

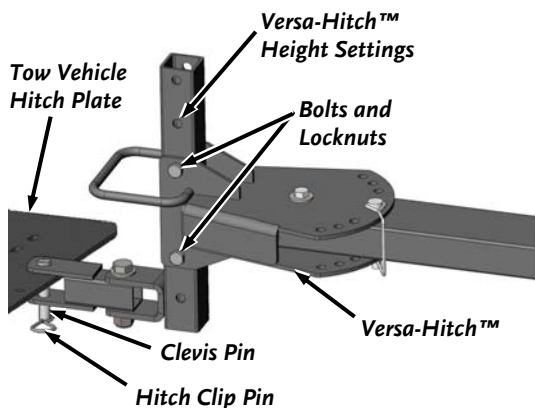

Figure 14

Connecting the TOW-BEHIND DR FIELD and BRUSH MOWER to your Tow Vehicle

The Versa-Hitch™ on the TOW-BEHIND DR FIELD and BRUSH MOWER Out-Rigger™ Tow Bar has four positions to accommodate different Tow Vehicle hitch heights. The Versa-Hitch™ positions are also for leveling the machine according to the Cutting Height setting of the machine. See page 16.

1. Move your Tow Vehicle to a reasonably flat area and set the Parking Brake. Lift the Versa-Hitch™ and position it onto the center of the Tow Vehicle Hitch Plate and secure with the Clevis Pin and Hitch Clip Pin (Figure 14).

NOTICE

For the machine to work properly, it is important to use the Versa-Hitch™ height setting that positions the Out-Rigger™ Tow Bar level with the ground.

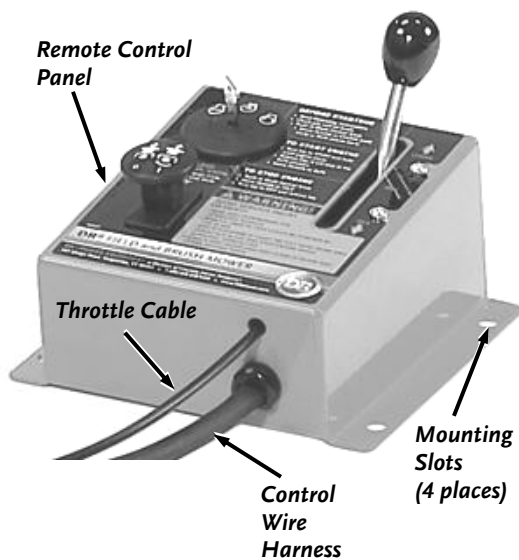

Figure 15

Attaching the TOW-BEHIND DR FIELD and BRUSH MOWER Remote Control Panel

1. Locate the Remote Control Panel (Figure 15) on your Tow Vehicle within reach of the seated Tow Vehicle driver.
2. Secure the Remote Control Panel by threading the Hook and Loop Straps provided with your TOW-BEHIND DR FIELD and BRUSH MOWER, through the Remote Control Panel Mounting Slots and then around a fixed object on your Tow Vehicle (Figure 16a and b).

NOTICE

Be sure to route the Throttle Cable and Control Wire Harness between the Hitch and the Remote Control Panel away from the muffler of the tow vehicle.

Checking the Tire Pressure

The maximum Tire pressure is marked on the side of each Tire. Do not exceed the manufacturer's recommended maximum pressure.

NOTE: They are Self-sealing Tubeless Tires to protect against minor punctures.

Mounted Remote Control Panel

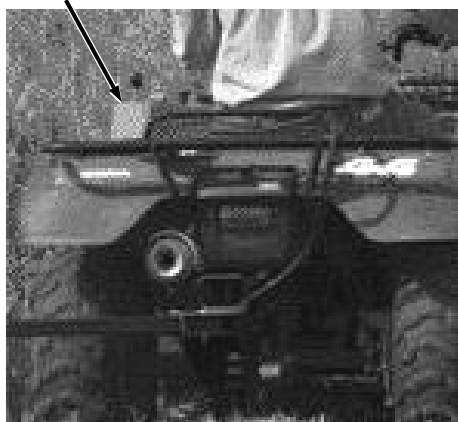

ATV Mounted

Figure 16a



Mower Mounted

Figure 16b

Chapter 3: Operating the TOW-BEHIND DR FIELD and BRUSH MOWER

This chapter covers the procedures for starting and stopping your new TOW-BEHIND DR FIELD and BRUSH MOWER and discusses basic operation features. You may find it helpful to review the TOW-BEHIND DR FIELD and BRUSH MOWER Controls and Features on page 7 before reading this chapter.

WARNING

- This machine is designed for cutting grass and brush. Never use this machine for any other purpose as it could cause serious injury.
 - Contact with internal rotating parts will cause serious personal injury. Never put hands, face, feet, or clothing under the deck or near the discharge area with the engine running.
 - Before performing any maintenance procedure or inspection, stop the engine and wait five (5) minutes to allow all parts to stop and cool. Disconnect the spark plug wire(s) keeping it away from the spark plug(s).
-

Operating Parameters

We recommend a few types of Tow Vehicles for the TOW-BEHIND DR FIELD and BRUSH MOWER. The Tow Vehicle may be either 2 or 4 wheel drive, but some vehicle types are not suitable for rough, hilly terrain or heavy brush conditions. See the Tow Vehicle Restrictions section below.

- ATV
- Lawn/Garden Tractor (17 HP and above and weighing at least 500 pounds)
- Riding Lawn Mower (14 HP and above and weighing at least 400 pounds)
- Utility Vehicle
- Compact or Sub-Compact Tractor

Tow Vehicle Restrictions:

- You must be able to secure the Remote Control Panel of the TOW-BEHIND DR FIELD and BRUSH MOWER within easy reach of the driver seated on the Tow Vehicle. The front of the Control Panel is 5' from the Versa-Hitch™. A Utility Vehicle with a bed longer than 2 ft. will not meet this restriction so you cannot use it as a Tow Vehicle.
- Riding Lawn Mowers with Engines under 17 HP and weighing less than 500 pounds are not suitable for use on slopes greater than 5°.
- Never operate your TOW-BEHIND DR FIELD and BRUSH MOWER on slopes greater than 20° using any type of Tow Vehicle.
- If your Tow Vehicle will not travel by itself over the terrain you plan to use it with the TOW-BEHIND DR FIELD and BRUSH MOWER, then it will not be suitable as a Tow Vehicle over that terrain.

Tip: Riding Lawn Mowers will work best as a Tow Vehicle with their cutting deck removed.

CAUTION

- We do not recommend driving over 5 mph on flat terrain and over 4 mph on rough terrain while operating your TOW-BEHIND DR FIELD and BRUSH MOWER.
 - Never use a truck (2 or 4wd) or jeep to operate the TOW-BEHIND DR FIELD and BRUSH MOWER. It would be difficult to see and you cannot operate the mower controls from these types of tow vehicles. Using these vehicles will void the TOW-BEHIND DR FIELD and BRUSH MOWER warranty.
-

Before Starting the Engine

! WARNING

Inspect the area where you will be working. The site must be free of potentially hazardous obstacles such as glass, large stones, sticks, wire, rope, and string-like materials. Make sure there are no people or animals in the area around the TOW-BEHIND DR FIELD and BRUSH MOWER.

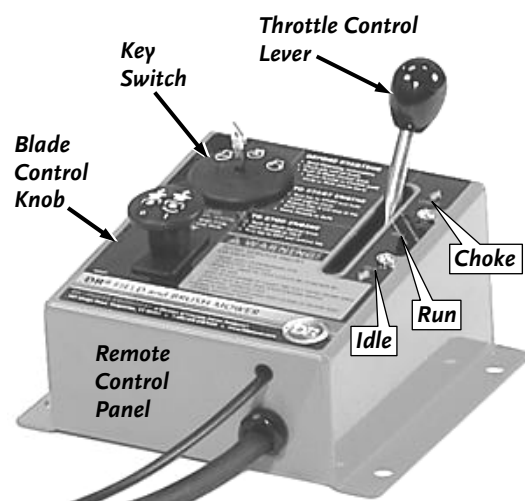

Figure 17



Figure 18

1. Check the oil level every time you use the machine (**Figure 4 on page 10**).
2. Check the gasoline level (**Figure 4 on page 10**).
3. **Pro and Pro-XL Models:** Open the Fuel Shut-Off Valve, which is located in the Fuel Line on the Fuel Tank Mount (**Figure 1b on page 8**).
4. Make sure the Blade Control Knob is pushed down to the disengaged position (**Figure 17**).

Note: The Blade Control Knob must be DOWN before starting.

Starting

Manual Starting (Premier Model)

1. Push the Blade Control Knob down to disengage the Blades (**Figure 17**).
2. When starting a cold Engine, push the Throttle Control Lever up to the CHOKE position. When starting an already warm Engine, push the Throttle Control Lever down to the RUN position.
3. Turn the Key to the RUN (center) position.
4. Grasp the Recoil Starter Handle and slowly pull until you feel resistance. Pull the cord rapidly to start the engine (**Figure 18**). Repeat as needed.
5. As the Engine warms up, slowly adjust the Throttle to the Run position. Wait until the Engine runs smoothly before each Throttle adjustment. For maximum performance, operate the Engine with the Throttle in the RUN position.

Electric Starting (Pro and Pro-XL Models)

1. Push the Blade Control Knob down to disengage the Blades (**Figure 17**).
2. When starting a cold Engine, push the Throttle Control Lever up to the CHOKE position. When starting an already warm Engine, push the Throttle Control Lever down to the RUN position.
3. Turn the Key Switch to the center position (ON), and then to the START position until the Engine starts, then release. The Key will snap back to the center position (ON) and the Engine will continue to run.
4. As the Engine warms up, slowly adjust the Throttle to the Run position. Wait until the Engine runs smoothly before each Throttle adjustment. For maximum performance, operate the Engine with the Throttle in the RUN position.

Stopping the Engine

NOTICE

Never stop the engine by moving the throttle control lever to the choke position. This could cause an engine backfire resulting in engine damage.

1. Disengage the Blades by pushing the Blade Control Knob down (**Figure 19**).
2. Move the Throttle Control Lever all the way down to the IDLE position and turn the Key to STOP.
3. Remove the Key for safety. The Key has a pressure lock that prevents it from vibrating loose during operation. To remove the Key, push it in and then quickly and firmly pull it out. If the Key becomes difficult to remove, apply a non-conductive lubricant into the Keyhole.

Note: Close the Fuel Shut-Off Valve when transporting or storing the TOW-BEHIND DR FIELD and BRUSH MOWER.

Engaging the Blades (Premier Model)

1. Engage the Blades by turning and holding the Key to the furthest right position as you pull UP on the Blade Control Knob (**Figure 19**). Release the Key and it will return to the run (middle) position.

Engaging the Blades (Pro and Pro-XL Models)

1. Engage the Blades by pulling UP on the Blade Control Knob (**Figure 19**).

Stopping the Blades

1. Push DOWN on the Blade Control Knob (**Figure 19**).

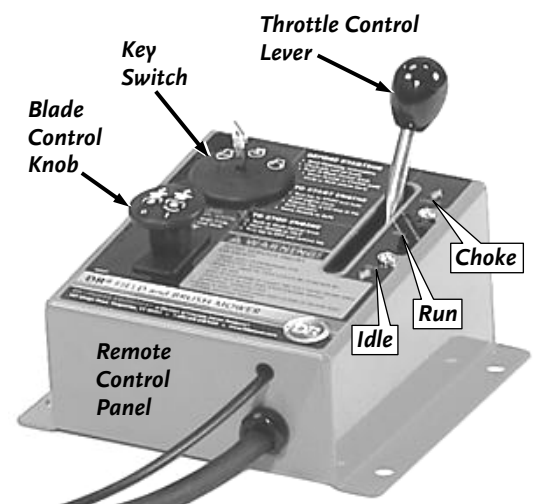

Figure 19

Adjusting the Mower Deck Height

! WARNING

- Shut off the engine before adjusting the deck height or serious injury may result. The blades could sever your foot if it sticks under the deck with the engine running.
- Never get off the tow vehicle without first stopping the blades and shutting off the tow vehicle engine and the TOW-BEHIND DR FIELD and BRUSH MOWER engine.

NOTE: The TOW-BEHIND DR FIELD and BRUSH MOWER Deck has four (4) cutting heights, 4", 5", 6-1/4" and 7-1/2".

! CAUTION

Keep your foot clear of the mower deck when adjusting the height. You could pinch your foot if it sticks under the deck.

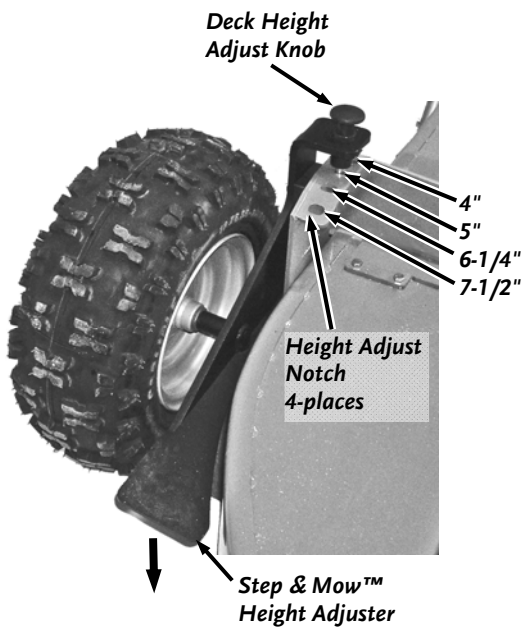

Figure 20

1. To change the cutting height, apply foot pressure to the Step & Mow™ Height Adjuster (**Figure 20**) and at the same time, lift up on the spring loaded Deck Height Adjust Knob and re-position the Knob to the desired height in one of the four Height Adjust Notches on top of the Deck. Repeat this for the opposite side of the Deck.

NOTE: Make sure that the left and right side Adjust Knob is the same notch for both sides.

Tip: Since you previously leveled the Out-Rigger™ Tow Bar when attaching it to your Tow Vehicle, whenever you change Cutting Height position up or down, just move the Versa-Hitch™ (**Figure 14 on page 17**) up or down to ensure that the Tow Bar is level or slightly lower at the Tow Hitch.

Offset Mowing

The Out-Rigger™ Tow Bar allows you to offset the cutting path of the TOW-BEHIND DR FIELD and BRUSH MOWER up to 100% from the Tow Vehicle. The provided locking positions are 0%, 50%, 75%, and 100%. Offset mowing allows you to mow closer to equipment, trees, and fences and to drive in area already cut.

CAUTION

When performing offset mowing, always be sure that the Out-Rigger™ Tow Bar angle setting (**Figure 21**) and the Versa-Hitch™ angle setting match. This allows the tow-behind DR field and brush mower to track parallel to the tow vehicle.

Offset at the Tow Bar Mount Plate:

1. Lift the Handle of the Tow Bar Locking Pin and rotate it (**Figure 22a**) to align the Spring Pins with the slot in the Tow Bar. Continue lifting until both Spring Pins are above the Tow Bar.
2. Rotate the Handle again until the Bottom Spring Pin is 90° to the Slots in the Tow Bar and lower the Handle until the Bottom Spring Pin (**Figure 22b**) rests on the Tow Bar. This is the unlocked position.
3. Move the Mower, using the Push Bar, until you have approximately aligned the Tow Bar with the desired Offset angle (**Figure 21**).
4. Lift the Handle and twist it until the Spring Pins align with the Slots in the Tow Bar. Press down to be sure to seat the Pin in the Mounting Plate hole (**Figure 22a**) at the desired location.

NOTE: If the Tow Bar alignment is correct and the Locking Pin is properly positioned, the Upper Spring Pin will not be showing. If the Upper Spring Pin is still visible, adjust the Tow Bar angle by moving the Mower until the Locking Pin can be pushed down into place and the Upper Spring Pin is no longer visible (**Figure 22b**).

5. Rotate the Handle to position the Upper Spring Pin out of alignment with the Slot in the Tow Bar (**Figure 22a**).

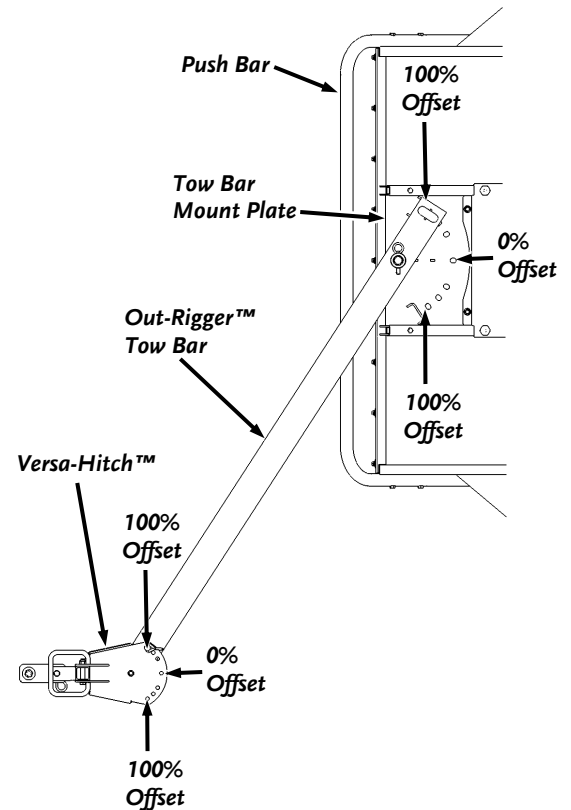

Figure 21

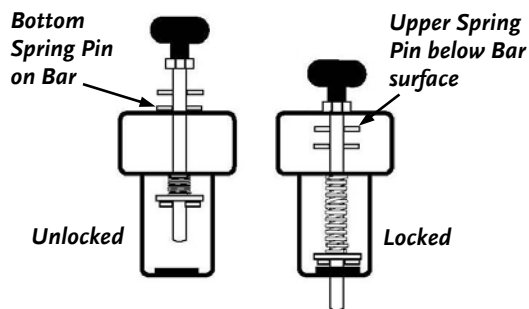

Figure 22b

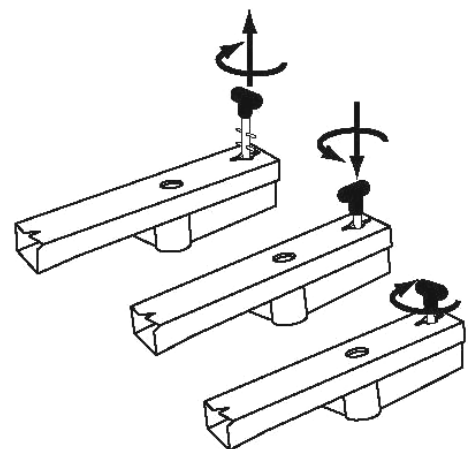

Figure 22a

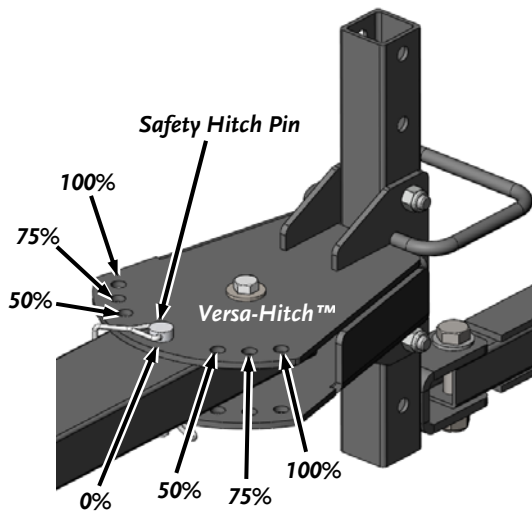

Figure 23

Offset at the Versa-Hitch™:

1. Remove the Safety Hitch Pin (**Figure 23**) from the Versa-Hitch™ and pull the Out-Rigger™ Tow Bar to the position that matches the Tow Bar position on the Deck. Re-attach the Safety Hitch Pin.

NOTE: The Versa-Hitch™ is parallel to the machine when the Offset at the Deck and the Offset at the Hitch are matched correctly.

Slopes and Uneven Terrain

! WARNING

- Check the owner's manual for your tow vehicle to determine its recommended towing capabilities on slopes.
- When operating the TOW-BEHIND DR FIELD and BRUSH MOWER over uneven terrain or slopes, use extreme caution not to tip over the machine.
- Never use the TOW-BEHIND DR FIELD and BRUSH MOWER on slopes greater than 20 degrees. Doing so could result in serious injury or damage to your machine.
- If you have to mow on sloping terrain, mow up and down, never across the slope, for better control.

If the machine gets hung up

1. Disengage the Blades and STOP the Engine. NEVER try to free the machine from stumps or debris with the Blades engaged.
2. Try driving over or backing away from the obstacle.

! WARNING

- If you need to leave the tow vehicle to clear debris from the mower deck, set the parking brake and shut off the tow vehicle engine, disengage the mower blades, shut off the TOW-BEHIND DR FIELD and BRUSH MOWER engine and disconnect the spark plug wire(s).
- Never touch the exhaust areas when reaching for the spark plugs; they may be very hot.

Cutting Brush and Saplings

- The cutting capacity is 1" for the Premier Model and 1-1/2" saplings for the Pro and Pro-XL Models.
- When cutting woody material, small saplings, etc., allow the machine to ride up and over material slowly. Adjust your forward speed to varying conditions.
- After cutting brush, etc., you may want to mow over it again to remove any remaining branches. It works best to mow from the trunk end toward the top as brush lies on the ground.
- If you are using Offset Mowing, keep the Offset at 75% when cutting heavy brush.

Cutting Wet and Heavy Growth

- Avoid steep slopes and other slippery areas.
- Use a lower, slower speed when mowing in wet conditions.

Chapter 4: Maintaining The TOW-BEHIND DR FIELD and BRUSH MOWER

This chapter covers regular maintenance procedures that will ensure the best performance and long life of your TOW-BEHIND DR FIELD and BRUSH MOWER. For Engine maintenance, please refer to the Engine Owner's Manual that came with your machine. Service intervals listed in the checklist below supersede those listed in the Engine Owner's Manual.

! WARNING

- When performing any adjustment or maintenance, you must first shut off the engine, wait five (5) minutes to allow parts to cool and disconnect the spark plug wire(s), keeping it away from the spark plug(s).
- Some of the following procedures require access to the underside of the machine. If you need to tip the machine back or on its side, you must first disconnect the spark plug wire(s), and drain the oil and gas.

Regular Maintenance Checklist

Note: Consider the service intervals shown as maximum under normal operating conditions. Increase frequencies under extremely dirty or dusty conditions.

PROCEDURE	BEFORE EACH USE	EVERY 20 HOURS	EVERY 100 HOURS
Check Engine Oil Level	▲		
Check General Condition, e.g. nuts, bolts, welds, etc.	▲		
Check the Blades Sharpness	▲		
Inspect the Debris Guard	▲		
Clean Engine Exterior & Cooling Fins	▲		
Check Cable connections		▲	
Check Tire Pressure (psi on side of tire)		▲	
Change Engine Oil and Filter NOTE: 1 st time after 5 hours		▲	
Replace Air Filter			▲
Replace Spark Plug(s)			▲
Replace In-line Gas Filter			▲

Removing and Replacing the Engine Oil (Premier and Pro Models)

Note: Drain the oil when the engine is warm. Warm oil drains quickly and completely.

Supplies Needed:

- Rags and a suitable container for used oil
 - SAE 30 High Detergent Oil
1. Remove the Oil Filler Cap and position a suitable oil drain container under the machine near the Oil Drain Valve on the side of the Engine (**Figure 24**).
 2. Open the Cap on the Oil Drain Valve and attach the Plastic Hose (provided in product package) to the Valve opening.
 3. Push in the Oil Drain Valve, turn it counterclockwise then pull it out for draining.
 4. When the Oil is completely drained, push the Oil Drain Valve in and turn clockwise until it locks into position.
 5. Remove the Hose and push the Cap fully onto the Oil drain Valve.
 6. Replace the oil by following the instructions "Adding Oil and Gasoline" in Chapter 2.

Note: Be sure to use environmentally safe disposal procedures in the disposing of the used oil.

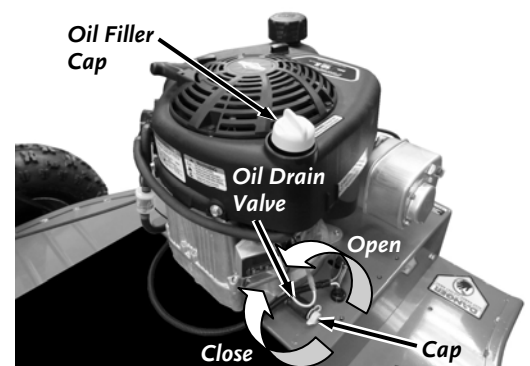

Figure 24

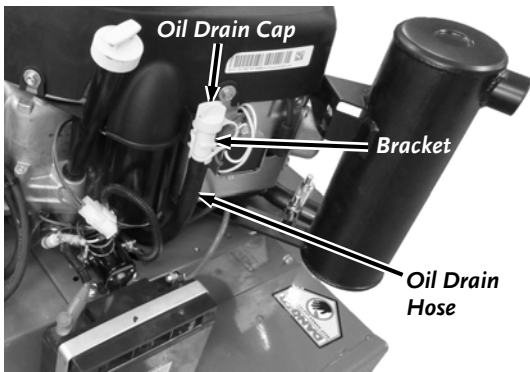

Figure 25

Removing and Replacing the Engine Oil and Filter (Pro-XL Model)

Note: Refer to the Engine Users manual for more detailed instructions for Engine maintenance. Drain the oil when the Engine is warm. Warm oil drains quickly and completely.

Tools and Supplies Needed:

- Oil Filter Wrench (obtainable from a local auto parts or hardware store)
- Rags and a suitable container for used oil
- SAE 30 High Detergent Oil

1. Turn the Oil Drain Cap a quarter turn counterclockwise and open the end of the Drain Hose Assembly (**Figure 25**).
2. Position an appropriate drain container near the Drain Hose.
3. Remove the Oil Drain Hose Assembly from the Bracket and lower the Cap

end over the Container to drain.

4. The Engine Oil Filter is located on the side of the Engine. Using an Oil Filter Wrench, or grasping the Oil Filter firmly with your hand, unscrew the Oil Filter counterclockwise from the Engine. **BE SURE THAT THE OLD FILTER GASKET COMES OFF WITH THE FILTER.**
5. Wipe the mounting base for the Oil Filter with a clean cloth.
6. Apply a thin coat of clean motor oil to the new Oil Filter Gasket. **DO NOT USE GREASE OR USED OIL.**
7. Line up the threads carefully to avoid cross threading and screw the new Oil Filter on until the Filter Gasket contacts the base, and then tighten the Oil Filter 3/4 to 1 turn. **DO NOT OVER TIGHTEN.**
8. Mount the Oil Drain Hose Assembly onto the Bracket and replace the Oil Fill Cap.
9. Refill the oil by following the instructions on page 12.
10. Reattach the Spark Plug wire(s).

Note: Be sure to use environmentally safe disposal procedures in the disposing of the used oil.

Removing and Replacing the Blades' Drive Belt

NOTICE

Use only DR belts on your machine. They have been thoroughly tested and proven for many hours of use.

Tools and Supplies Needed:

- 3/8", 7/16", 1/2" and 9/16" Wrenches
- Flat Screwdriver
- 17" Cable Tie (for Carbon Canister version)
- Side Cutters or Scissors
- Hooked End Pulling Tool - Optional (we suggest a Tent Peg Puller)

1. For Pro and Pro-XI Models, Turn the Fuel Shut-Off Valve to the OFF position (**Figure 26**).
2. Remove the Bolts and Lock Washers from both sides of the Fuel Tank Mount using a 1/2" Wrench.
3. Using a 3/8" Wrench or Socket, remove the three Bolts, Lock Washers, and Flat Washers that retain the Pulley Cover.
4. Lift up the front of the Fuel tank Mount so you can remove the Pulley Cover (**Figure 27**).
5. Remove the Strain Relief (with Wire Harness) from the Fuel Tank Mount by pushing the Locking Tabs in with a screwdriver and pushing it into and down out of the cutout.
6. Carefully lift and set the Fuel Tank Mount to the Fuel Line side of the Engine (right hand side) (**Figure 28**).
7. Using a 9/16" Wrench, remove the top Nut from the Belt Tension Spring Mounting Stud.
8. Using a Hooked End Pulling Tool, remove the Belt Tension Spring from the Mounting Stud by hooking the Tool in the Spring End and pulling the Spring up and over the Stud.

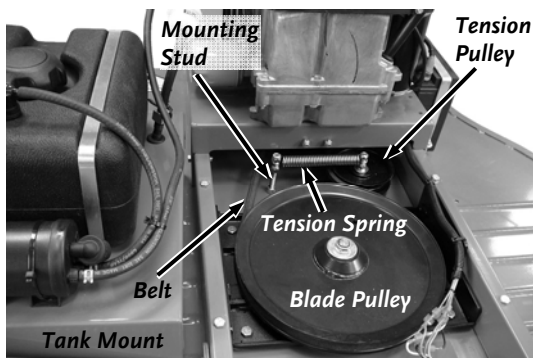

Figure 28

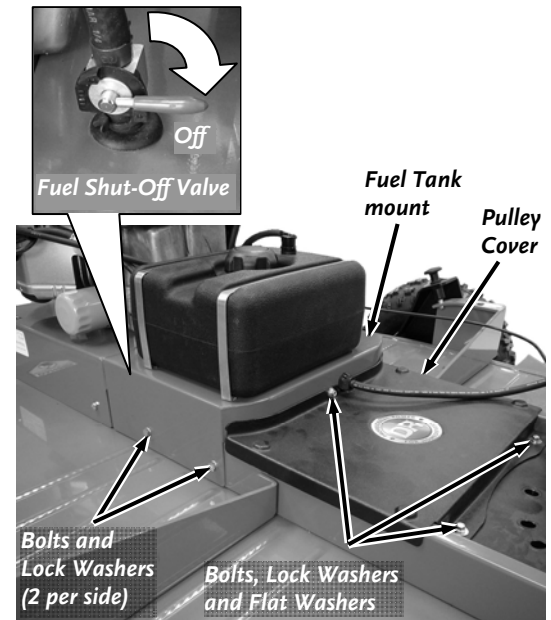

Figure 26

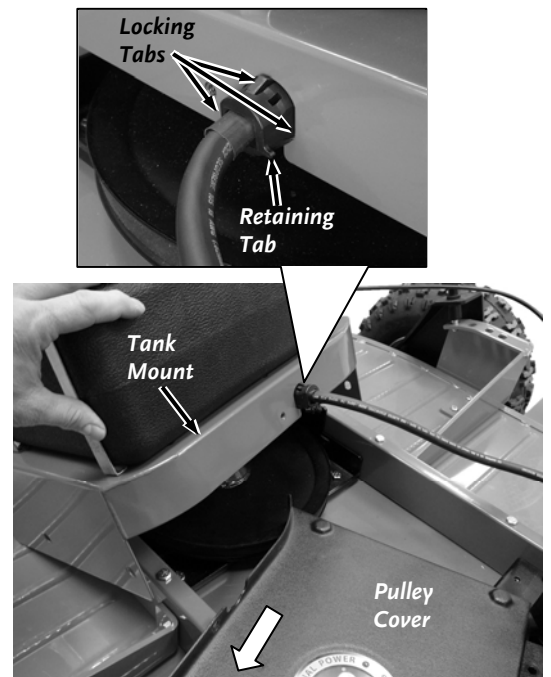

Figure 27

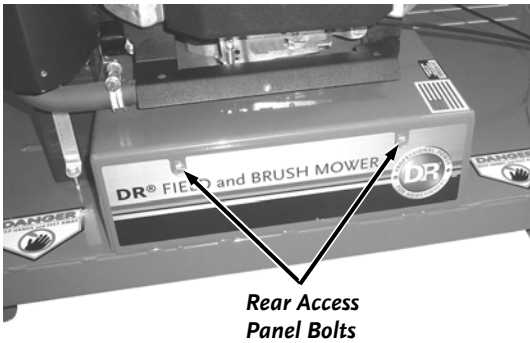

Figure 29

9. Using a 7/16" Wrench or Socket, remove the two Bolts and Lock Washers that retain the Rear Access Panel on the Mower and remove the Panel (**Figure 29**). This will open access to the Drive Pulley for Belt removal and installation.
10. Slip the old Drive Belt from the Blade Pulley and from the Drive Pulley beneath the Engine at the Rear of the Mower.
11. To install the new Belt, follow the above procedure in the reverse order making sure that the Belt is on the inside of the Tension Pulley (**Figure 28**).

Note: When reinstalling the Wire Harness back into the Fuel Tank mount you will need to start the Retaining Tab through first to get the Strain Relief into the hole.

See Figure 30.

For the Pro-XL: Before tightening the Cable Tie that secures the Throttle Cable to the Carbon Canister, make sure you allow enough slack in the Cable for Tow Bar side to side adjustment.

Removing and Replacing the Swinging Blades

Note: Replace the Blade(s) when worn or damaged.

Tools and Supplies needed:

- Two 15/16" Wrenches
- Gloves

⚠ WARNING

Wear gloves and use caution when pushing or pulling the wrench next to the blade. If the wrench slips off the bolt you may be seriously injured.

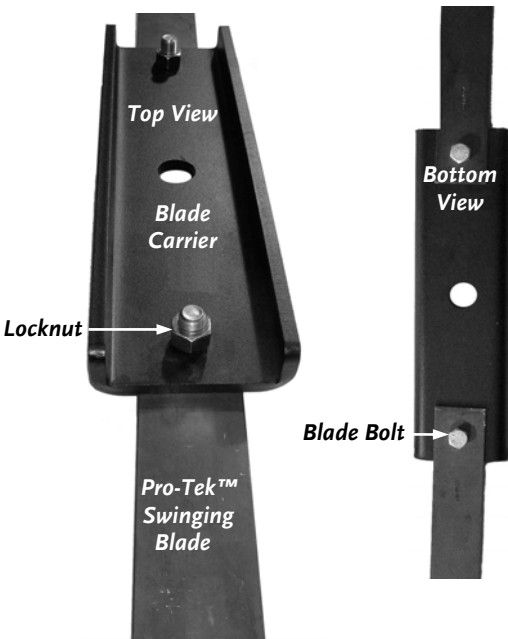

Figure 30

1. Using two 15/16" Wrenches, remove the Top Lock Nut (right-hand, regular thread) and then the Blade Bolt followed by the Pro-Tek™ Swinging Blade (**Figure 30**).

2. Reinstall the sharpened or a new Pro-Tek™ Swinging Blade in the

orientation shown (**Figure 31**).

3. Install the Locknut until it just touches the Blade Carrier using two 15/16" Wrenches to allow for the Blade Swinging action (**Figure 30**).

4. Repeat steps 1 through 3 for the other Pro-Tek™ Swinging Blade.

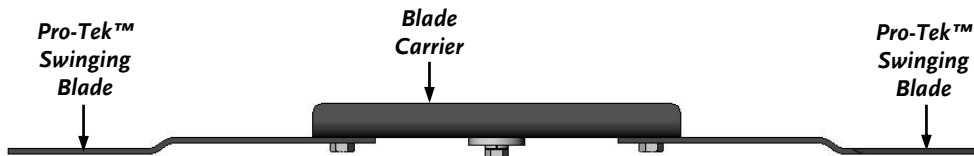

Figure 31

Replacing the Wheels

Tools needed:

- 9/16" Wrench or Socket
1. With the weight of the machine on the wheel, loosen (counterclockwise) the Axle Bolt (**Figure 32**) with a 9/16" Wrench or Socket.
 2. Block the machine up off the ground so that the Wheel you are removing spins freely, remove the Axle Bolt, Lock Washer, Flat Washer, and Outer Bushing.
 3. Slide the Wheel from the Axle.

Note: If the Inner Bushing should slip out when removing the Wheel, simply re-insert it on the Step & Mow™ Axle Shaft.

4. Replace the Wheel and hardware in the reverse order.

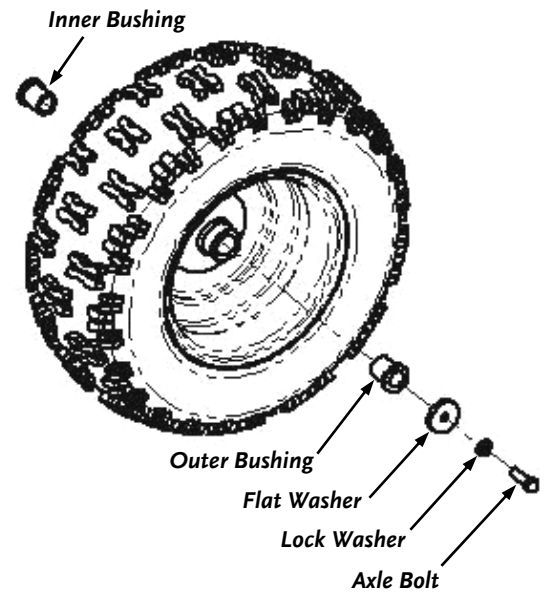

Figure 32

Debris Guard Replacement

The purpose for this section is to be sure the operator of the TOW-BEHIND DR FIELD and BRUSH MOWER is aware of the potential unsafe condition of operating the machine with a damaged Debris Guard.

⚠ WARNING

Do not operate your TOW-BEHIND DR FIELD and BRUSH MOWER with a damaged debris guard. Failure to replace the damaged debris guard can result in thrown objects hitting the operator, which can cause severe injury.

- Inspect the Debris Guard before each use and often during use. If you notice damage to the Debris Guard, DO NOT continue to use your machine.
- If your Debris Guard becomes worn or damaged it MUST be replaced.

Tools needed:

- 7/16" Wrench
 - Two 1/2" Wrenches
1. Remove the machine from the tow vehicle and ensure that it is located in a clean flat area.
 2. Set the Tow Bar in the straight forward position and block the tires to prevent the machine from moving.
 3. Lift the Tow Bar until the back of the machine touches the ground and position a Jack Stand under the Tow Bar. This will allow enough clearance for Push Bar removal.
 4. Remove the two Bolts (one Bolt on each side) that secure the Debris Guard using a 7/16" Wrench (**Figure 33**).
 5. Using two 1/2" Wrenches, remove the four Bolts and Locknuts on each side of the Brush Guard to remove the Brush Guard from the Deck (**Figure 34**).

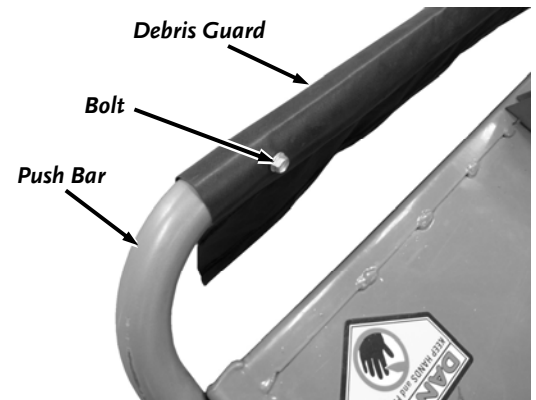

Figure 33

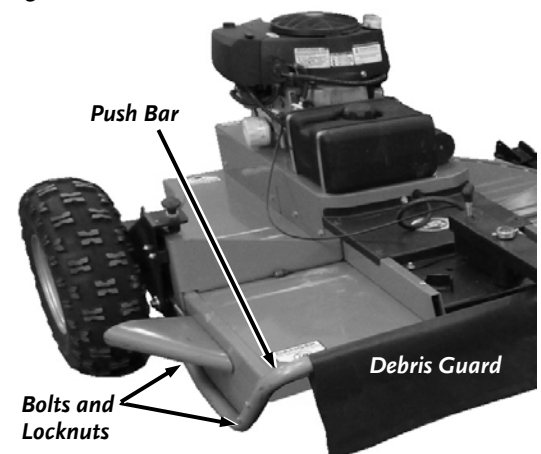

Figure 34

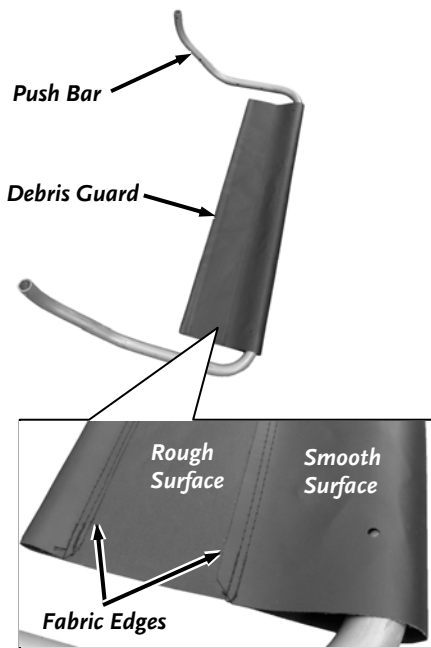

Figure 35

Note: The new Debris Guard must be installed with the smooth side facing forward and the side with the stitched fabric edges and rougher surface facing towards the back of the machine (Figure 35).

6. Insert one end of the Push Bar into the new Debris Guard opening and slide the Debris Guard on until it is fully on the front portion of the Push Bar.

Note: You may need to work back and forth, pulling from the end of the Debris Guard and pushing where it was first started to aid in installation.

7. Reinstall the Push Bar with new Debris Guard onto the machine. Secure with four Bolts and Locknuts on each side using two 1/2" Wrenches.
8. Position the Debris Guard to align the holes and use a 7/16" Wrench to install the two Bolts at both sides of the Guard. The Bolt needs to be snug against the Push Bar but do not tighten enough to twist the Fabric excessively.

Replacing the Carbon Canister (Pro and Pro-XL Models)

Tools needed:

- Wire Cutters
- Pliers

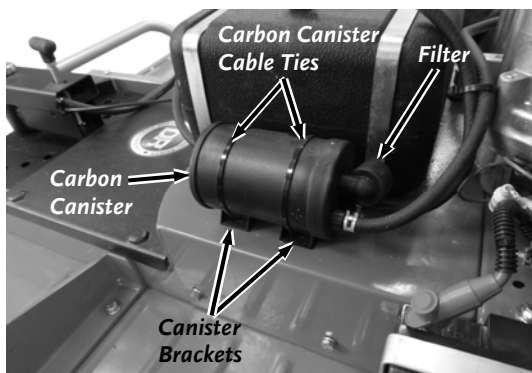

Figure 36

1. Pull the Filter from the Carbon Canister. (Figure 36).
2. Cut the two Cable Ties that are securing the Carbon canister to the Canister Brackets.
3. Slide the Hose Clamp down from the Hose connection with Pliers and twist the Hoses from the Canister (Figure 37).

Note: The Hoses MUST be installed onto the new Canister in the same location as they were on the old Canister. The Canister is labeled "Purge" (this hose is from the engine) and "Tank" (this hose is from the top of the fuel tank).

4. Install the Hoses onto the new Carbon Canister and position the Hose Clamp with Pliers.
5. Slide new Cable Ties through the Canister Brackets and position the Canister onto the Brackets with the Tabs on the bottom of the Canister into the Bracket cavities. Make sure the Filter is facing down (the filter can be rotated if needed).
6. Tighten the Cable Clamps around the Canister and cut the excess with Wire Cutters.

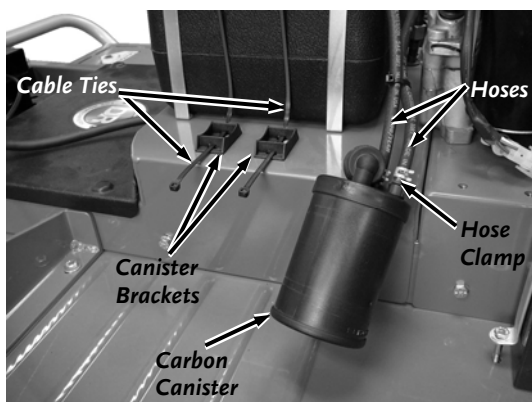

Figure 37

Battery Care (Pro and Pro-XL Models)

Proper care can extend the life of a Battery. Follow these recommendations to ensure your Battery's best performance and long life:

- Do not allow the Battery charge to get too low. If the machine is not used, charge the Battery every 4 – 6 weeks. Operate the Engine for at least 45 minutes to maintain proper Battery charge.
- Store an unused Battery in a dry area that does not freeze.
- Do not charge an already charged Battery. In theory, you cannot overcharge our Battery with a trickle charger; however, when a Battery is fully charged and the charger is still on, it generates heat that could be harmful to the Battery. A fully charged Battery will read 12V-13.2V with a voltmeter.
- Do not continue to crank the Engine when the Battery charge is low.

Chapter 5: Troubleshooting

Most problems are easy to fix. Consult the Troubleshooting Table below for common problems and their solutions. If you continue to experience problems, contact us at www.DRpower.com or call toll-free 1-800-DR-OWNER (376-9637) for support.

WARNING

When performing any adjustment or maintenance, you must first shut off the engine, wait five (5) minutes to allow parts to cool and disconnect the spark plug wire(s), keeping it away from the spark plug(s).

Troubleshooting Table

SYMPTOM	POSSIBLE CAUSE
<p><i>The Engine will not start.</i></p> <p><i>(Please refer to the Engine Owner's Manual for Engine-specific procedures.)</i></p>	<ul style="list-style-type: none"> ⇒ Check all the items under the section called "Starting" on page 18. ⇒ Check that the Blade Control Knob is DOWN in the Disengaged position. ⇒ Make sure the Spark Plug wire(s) is attached. ⇒ If the Engine is cold, make sure the Throttle is in the CHOKE position. See "Starting" on page 18. ⇒ The gas must be fresh and clean. If the gas is old, change it. Use a fuel stabilizer if you keep gas longer than one month. ⇒ Check the Throttle adjustment and travel. See page 14. ⇒ The Spark Plug(s) may be dirty or cracked, change it. ⇒ If the Spark Plug(s) is oily, leave it out, hold a rag over the Plug hole(s) and crank the Engine over a couple of times using the Electric Starter to blow out any oil in the Cylinder(s), then wipe off the Plug(s) and reinsert it. ⇒ The Air Filter may be dirty, change it following the procedure in the Engine Owner's Manual. ⇒ There are two Fuses in the Wiring Harness. Check the Fuses and replace if needed. ⇒ Check the wire connections—especially the ground connection, the large green wire coming from the Battery, where it connects to the Engine. ⇒ The Battery may not be charged. Check the voltage yourself or at a service station. If it is low, charge it with a 12-volt, 1 to 2-amp trickle charger. If you do not use your machine for at least 45 minutes at a time, the Battery may need to be periodically charged. See the "Battery Care" section on page 28. ⇒ If the Battery is charged and your DR TOW-BEHIND FIELD & BRUSH MOWER still will not start, visit our website at www.DRpower.com or call 1-800-DR-OWNER (376-9637) for assistance.
<p><i>The Engine lacks power or is not running smoothly.</i></p> <p><i>(Please refer to the Engine Owner's Manual for Engine-specific procedures.)</i></p>	<ul style="list-style-type: none"> ⇒ Check the Throttle Lever travel and adjustment. Make sure the Throttle Lever is in the Run position. ⇒ The Air Filter may be dirty, change it following the procedure in the Engine Owner's Manual. ⇒ The Spark Plug(s) may be dirty or cracked, change it. ⇒ If the Spark Plug(s) is oily, leave it out, hold a rag over the Plug hole(s) and crank the Engine over a couple of times using the Electric Starter to blow out any oil in the Cylinder(s), then wipe off the Plug(s) and reinsert it. ⇒ The gas must be fresh and clean. If the gas is old, change it. Use a fuel stabilizer if you keep gas longer than one month. ⇒ The Engine may not have the right amount of clean oil. If it is dirty, change it following the procedure on page 23. ⇒ If the Engine still lacks power, visit our website at www.DRPower.com or call 1-800-DR-OWNER (376-9637) for assistance.

! WARNING

When performing any adjustment or maintenance, you must first shut off the engine, wait five (5) minutes to allow parts to cool and disconnect the spark plug wire(s), keeping it away from the spark plug(s).

Troubleshooting Table (Continued)

SYMPTOM	POSSIBLE CAUSE
<i>Engine smokes.</i>	<ul style="list-style-type: none">⇒ Check the oil level and adjust as needed.⇒ You may be operating the machine on too great an incline. See “Slopes and Uneven Terrain” on page 22.⇒ Check the Air Filter(s) and clean or replace if needed.⇒ You may be using the wrong oil—too light for the temperature. Refer to your Engine Owner’s Manual for detailed information.⇒ Clean the Cooling Fins and the Carburetor housing if they are dirty.⇒ If the Engine still smokes, visit our website at www.DRPower.com for assistance
<i>The Belt frays or rolls over the Pulley.</i>	<ul style="list-style-type: none">⇒ There may be a nick in a Pulley groove. Check the Belt for wear and hard spots. File off any nicks on the Pulley.⇒ The Belt may be stretched; replace it. See page 25.
<i>Blades vibrate when engaged.</i>	<ul style="list-style-type: none">⇒ The Blade Carrier Mounting Bolt may not be tight enough. Tighten the Bolt as tight as possible by hand with at least a 1ft long 13/16" Wrench.⇒ A Swinging Blade may be too loose on the Blade Carrier. Re-tighten the Swinging Blade mounting hardware. See page 26. Be sure to turn OFF the Engine and remove the Spark Plug wire(s) before performing this operation.⇒ Replace a Swinging Blade if it is chipped, bent, or broken.⇒ The Spindle Bearings may be damaged or the Spindle Shaft is bent.⇒ Call 1-800-DR-OWNER (376-9637) for assistance.
<i>The Blades are not cutting or are loose.</i>	<ul style="list-style-type: none">⇒ The Blade Carrier Mounting Bolt may not be tight enough. Tighten the Bolt as tight as possible by hand with at least a 1ft long 13/16" Wrench.⇒ A Swinging Blade may be too loose on the Blade Carrier. Re-tighten the Swinging Blade mounting hardware. See page 26. Be sure to turn OFF the Engine and remove the Spark Plug wire(s) before performing this operation.⇒ Sharpen the Swinging Blades; they may be dull or nicked.
<i>The Blades will not Engage and/or Disengage.</i>	<ul style="list-style-type: none">⇒ Faulty Blade Control Switch. Remove and replace the Switch on the Remote Control Panel.⇒ Faulty Electric Clutch. Call 1-800-DR-OWNER (376-9637) for assistance.⇒ Low or weak battery may cause electric clutch to not engage. Check battery for sufficient voltage.
<i>Uneven cut.</i>	<ul style="list-style-type: none">⇒ The Step & Mow™ Height Adjuster and Versa-Hitch™ position are out of sync. Adjust the cutting height or Versa-Hitch™ position so that the Out-Rigger™ Tow Bar is level with the ground.⇒ Left and Right Step & Mow™ Height Adjusters are not at the same setting.
<i>Clogging at discharge.</i>	<ul style="list-style-type: none">⇒ The Step & Mow™ Height Adjuster and Versa-Hitch™ position are out of sync. Adjust the cutting height or Versa-Hitch™ position so that the Out-Rigger™ Tow Bar is level with the ground.
<i>Excessive Engine stalling.</i>	<ul style="list-style-type: none">⇒ The brush or grass is too heavy at the current cutting height or at the current Tow Vehicle speed. Raise the cutting height and drive slower when cutting.

Chapter 6: Parts Lists and Schematic Diagrams

Parts List - Deck and Drive Assembly (For Premier specific parts see page 34)

NOTE: Part numbers listed are available through DR Power Equipment.

Ref#	Part#	Description	Ref#	Part#	Description
01	22950	Deck w/Labels	37	22214	Bolt, 7/16-20 x 2-1/4", Locking, HCS, GR8
02	22136	Support, Deck	38	22141	Anti-Rotation Bracket
03	22213	Bolt, 5/16-18 x 3-5/8", HCS, GR5, ZP	39	12321	Bolt, 5/16-18 x 3/4", HCS, GR5, ZP
04	11241	Washer, Flat, 5/16", USS, ZP	40	22133	Belt, BP51, 5/8" x 53.8"
05	11076	Nut, Nylon Lock, 5/16-18, ZP	41	22220	Idler Arm
06	22245	Valve, 3/8" NPT, Oil Drain (16.5 HP)	42	22221	Bushing, .390" ID x .625" OD x .78"
07	22138	Mount, Tow Bar, Deck	43	11985	Bolt, 3/8-16 x 1-1/2", HCS, GR5, ZP
08	22246	Bolt, 3/8-16 x 3/4", HCS, GR8, ZP, YZP	44	11239	Washer, Flat, 3/8", USS, ZP
09	22247	Bolt, 3/8-16 x 2-1/4", HCS, GR8, ZP, YZP	45	15127	Pulley, Flat Idler, 4", 3/8" Bore
10	18081	Washer, Lock, 3/8", Split	46	15069	Bolt, 3/8-16 x 2-1/2", HCS, GR5
11	22129	Spindle, Housing	47	15094	Spring, Ext., 3/4" OD x 5" L
12	22888	Bolt, 3/8-16 x 1", HCS, GR8, ZP, YZP	48	17926	Bolt, 3/8-16 x 3-1/2", HCS, GR5, ZP, Full Thread
13	11075	Nut, Nylon Lock, 3/8-16, ZP	49	28949	Wire Harness, Solenoid (20 HP)
14	22130	Shaft, Spindle, w/Key & Bearing		27943	Wire Harness Solenoid (16.5 HP)
15	22131	Bearing, Ball, 30mm Bore	50	15250	Bolt, 1/4-20 x 3/4", HCS, w/Flange
16	22132	Pulley, 12.00" EOD, 1.00" Bore	51	10181	Washer, Lock, 1/4", Split, ZP
17	15745	Washer, Flat, 5/8", USS, ZP	52	11238	Washer, Flat, 1/4", USS, ZP
18	22126	Nut, Nylon Lock, 5/8-18, Low Profile, ZP	53	23081	Strain Relief, 1/2" Cord
19	21240	Spindle Hub, 30mm Bore	54	10483	Battery, 12V, 17Ah
20	22122	Blade Carrier	55	12451	Clamp, Battery, 7-1/8" X 5-1/2"
21	10177	Washer, .64" ID x 2-1/4" OD x 3/8", ZP	56	11148	Bolt, 1/4-20 x 1-3/4", HCS, GR5, ZP
22	21258	Washer, Lock, 5/8", Split, Heavy Duty, YZP	57	11073	Nut, Nylon Lock, 1/4-20, ZP
23	21241	Bolt, 5/8-18 x 1-3/4", HCS, GR8, ZP, YZP	58	15014	Wire, Ground, 16"
24	22121	Blade, Swinging, 16-1/2" x 2-1/2"	59	11243	Washer, Lock, 5/16", Split, ZP
25	31264	Nut, 5/8-18, Nylon Loc, GR8, ZP	60	24726	Cover, Belt w/Label
26	23402	Bolt, 5/8"-18 x 1-1/2", GR8, ZP	61	22952	Cover, Clutch Access w/Label
27	34101	Engine, B&S, 16.5HP, Pro Series, E/S	62	11248	Washer, Lock, 1/4", Ext. Tooth
	34099	Engine, B&S, 20HP, V-twin, E/S	63	24054	Strain Relief, .5" Cord
28	34131	Muffler, Exhaust, Briggs 20 HP, V-twin	64	16413	Nut, Nylon Lock, 3/8-16, Low Profile
29	22137	Mount, Engine	65	28990	Bolt, Tri Lobe, 3/8-16 x 1"
30	22885	Bolt, 5/16-18 x 1-1/2", HCS, GR8, ZP	66	28337	Mount, Fuel Tank
31	22927	Bolt, 5/16-18 x 1-3/4", HCS, GR8, ZP	67	28336	Fuel Tank, 2.5 Gal, Certified
32	22142	Spacer, Clutch	68	22237	Strap, 2.5 Gal Tank
33	33386	Clutch, Elec, 75 ft-lbs, 3.86a, w/Key (10.5 HP and 16.5 HP)	69	11070	Nut, Hex, 1/4-20, ZP
	28522	Clutch, Electric, 95 ft-lbs (20HP)	70	22244	Grommet, 1/2" ID x .12" Mount, Rubber
34	29674	Valve, Fuel Tank Vapor (included in item 67)	71	22239	Valve, Fuel Shutoff
35	19130	Washer, Flat, .469" ID x 1-5/8" OD x 1/4"	72	10066	Clamp, Fuel Line
36	22252	Washer, Lock, 7/16", Heavy Duty	73	21166	Hose, Fuel, Certified
			74	26575	Carbon Canister, 300cc, 3/16" Ports

<u>Ref#</u>	<u>Part#</u>	<u>Description</u>	<u>Items Not Illustrated</u>	
75	26577	Bracket, Canister	14002	Tubing, Oil Drain (10.5 HP and 16.5 HP)
76	12797	Cable Tie, 17" Long	14220	Fuse, 20 Amp, Type AGC
77	26579	Screw, 6-32 X 1/2", Phil Pan, ZP	22900	Fuse, 7 Amp, Type AGC
78	27822	Nut, 6-32, Nylon Lock	11214	Cable Tie, 7-1/2" L
79	10181	Washer, Lock, 1/4", Split, ZP	34121	Spring, Throttle Return
80	26580	Hose, Vapor, 3/16", ID	11194	Spring, Throttle Return (20hp)
81	26581	Clamp, Vapor Hose	34331	Muffler Guard
82	27710	Cap, Fuel W/ Tether (included in item 67)	34332	Screw, Guard
83	29675	Grommet, Vapor Valve (included in item 67)	34333	Deflector
84	14232	Key Square 1/4"x1"L (20 HP)	34130	Gasket, Exhaust, Briggs 20 HP, V-twin
85	34334	Static Cover, B&S 16.5 HP	34132	Manifold, Exhaust, Briggs 20 HP, V-twin
	34337	Static Cover, B&S 20 HP	<u>Safety and Information Labels</u>	
86	34335	Screw, Static Cover, 16.5 HP	23093	Label, DR Tow-Behind Field & Brush Mower
	34338	Screw, Static Cover, 20 HP	24053	Label, DR, 4" Round
87	15045	Bolt, 5/16-18 x 1-3/4",HCS, GR5, ZP	13649	Label, Danger
			13683	Label, Caution Hot Surface
			13758	Label, Check Oil
			23090	Label, Serial Number
			35507	Label, EPA Cert, 2015

Schematic – Deck and Drive Assembly (For Premier specific parts see page 35)

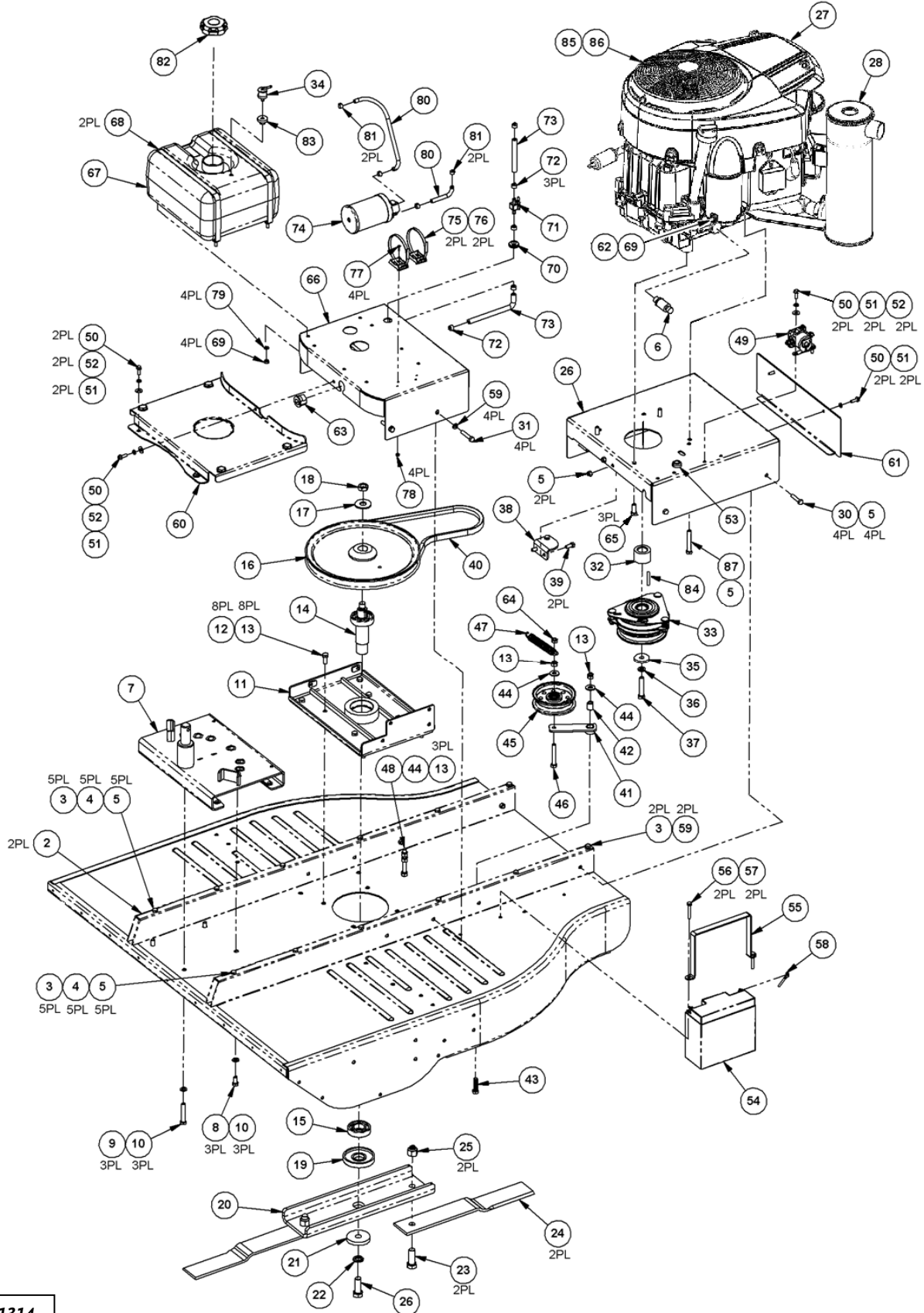

011314

Parts List – Premier Specific Parts

NOTE: Part numbers listed are available through DR Power Equipment.

<u>Ref#</u>	<u>Part#</u>	<u>Description</u>	<u>Ref#</u>	<u>Part#</u>	<u>Description</u>
1	34359	Engine, 10.5HP B&S, MS W/labels	12	22224	Cable & Lever, Throttle, 154" (10.5HP & 16.55HP)
2	22245	Valve, 3/8" NPT, Oil Drain	13	33386	Clutch, Elec, 75 ft-lbs, 3.86a, w/Key (10.5HP and 16.5 HP)
3	31335	Plate, Block-Off, 10.5HP	14	19130	Washer, Flat, .469" ID x 1-5/8" OD x 1/4"
4	11250	Washer, Star, 5/16, ZP	15	22252	Washer, Lock, 7/16", Heavy Duty
5	11069	Nut, Hex, 5/8-18, GR2, ZP	16	22214	Bolt, 7/16-20 x 2-1/4", Locking, HCS, GR8
6	32319	Wire Harness, Engine, 10.5HP	17	11478	Screw, 10-24 x 5/8", Phil Pan, ZP
7	10181	Washer, Lock, 1/4", Split, ZP	18	11873	Nut, Nylon Lock, 10-24, ZP
8	11070	Nut, Hex, 1/4-20, ZP	19	32318	Wire Harness, Control, 10.5HP
9	15045	Bolt, 5/16-18 x 1-3/4", HCS, GR5, ZP			
10	28990	Bolt, Tri Lobe, 3/8-16 x 1"			
11	22142	Spacer, Clutch			

Schematic – Premier Specific Parts

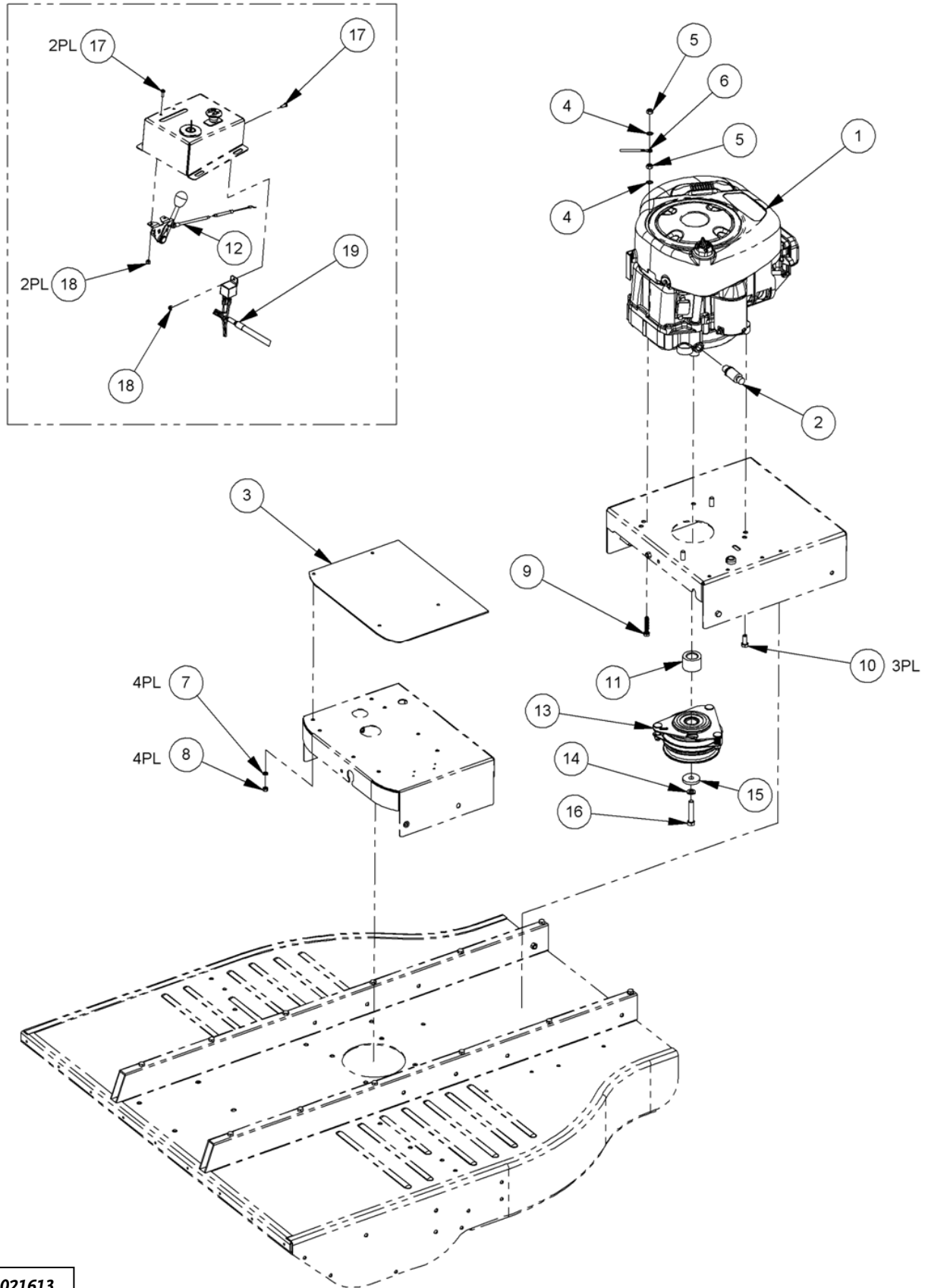

021613

Parts List – Wheels and Push Bar Assembly

NOTE: Part numbers listed are available through DR Power Equipment.

<u>Ref#</u>	<u>Part#</u>	<u>Description</u>	<u>Ref#</u>	<u>Part#</u>	<u>Description</u>
01	24025	Support, Axle Pivot, RH	16	22151	Bushing, .75" ID x 1.00" OD x 1.25", Flange
02	24024	Support, Axle Pivot, LH	17	24035	Deflector, Wheel, RH
03	12321	Bolt, 5/16-18 x 3/4", HCS, GR5, ZP	18	24034	Deflector, Wheel, LH
04	11076	Nut, Nylon Lock, 5/16-18, ZP	19	22246	Bolt, 3/8-16 x 3/4", HCS, GR8, ZP
05	24023	Axle, Adjustable, RH	20	22134	Push Bar
06	24022	Axle, Adjustable, LH	21	22927	Bolt, 5/16-18 x 1.75", HCS, ZP
07	22150	Bushing, 1.0" ID x 1.25" OD x 1.0" L	22	33561	Guard, Front PVC
08	22886	Bolt, 3/8-16 x 1-1/4", HCS, GR8, ZP	23	18013	Screw, Tri-Lobe 1/4-20 x 1.0", ZP
09	18081	Washer, Lock, 3/8", Split, ZP	24	11238	Washer, Flat, 1/4", USS, ZP
10	22887	Washer, .385" ID x 1.50" OD x .25", ZP	25	11158	Bolt, 5/16-18 x 1", HCS, GR5, ZP
11	22159	Pin Assy, 1/2", w/Spring			
12	23082	Spacer, 2.5" x 1.25" x .75", Nylon			
13	16086	Bolt, 1/4-20 x 1.25", HCS, ZP			
14	11073	Nut, Nylon Lock, 1/4"-20, ZP			
15	22232	Wheel, 18" x 6.5-8, 1.0" Bore x 3.0" Long			

Schematic – Wheels and Push Bar Assembly

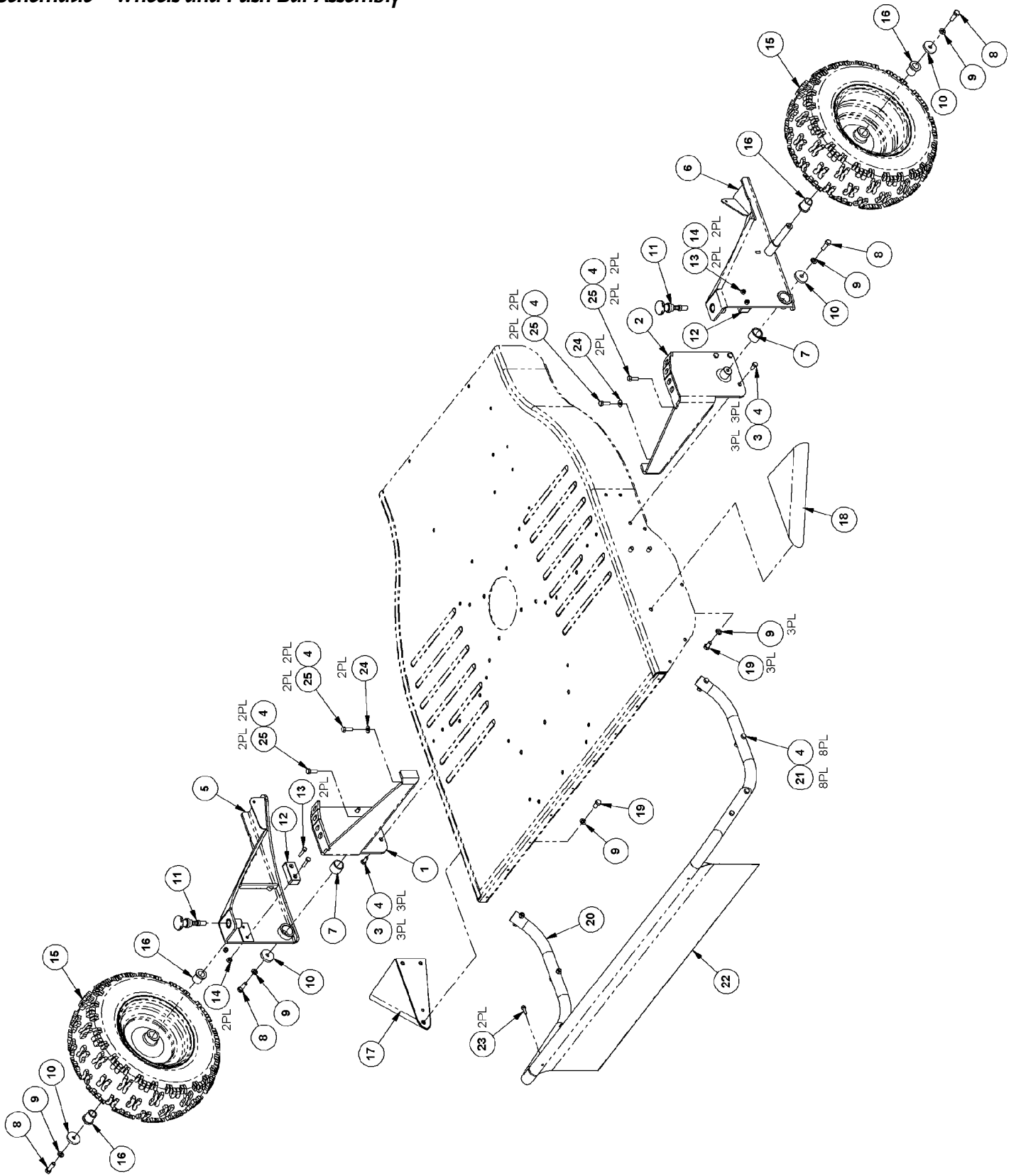

020615

Parts List – Tow Bar and Remote Control Panel Assembly

NOTE: Part numbers listed are available through DR Power Equipment.

<u>Ref#</u>	<u>Part#</u>	<u>Description</u>	<u>Ref#</u>	<u>Part#</u>	<u>Description</u>
01	24807	Tow Bar, w/Bushing	21	15720	Key, Ignition Switch
02	22156	Bushing, 1.75" ID x 2.00" OD x 2.75", Teflon	22	19123	Switch, Push/Pull, TPDT
03	22149	Washer, 1.00" ID x 1.62" OD, w/Pin Hole	23	22224	Cable & Lever, Throttle, 154" (10.5HP and 16.5HP Engines)
04	15046	Pin, Detent, 1/4" x 2", ZP		22248	Cable & Lever, Throttle, 170" (20HP Engine)
05	23498	Pin, Pivot, Tow Bar	24	23091	Knob, 3/8"-24, Mount, 1.12" OD
06	22154	Pin, Spring, 1/8" x 1", ZP	25	11478	Screw, 10-24 x 5/8", Phil Pan, ZP
07	22155	Knob, 3/8"-16, 2.5" Long x 7/8" Wide T	26	11873	Nut, Nylon Lock, 10-24, ZP
08	12683	Nut, Hex, 3/8"-16, ZP	27	22226	Wire Harness, Control
09	21348	Spring, C, .660" OD x .067" Wire x 2.0"	28	23081	Strain Relief, 1/2" Cord
10	23499	Washer, .53" ID x 1.06" OD x .095", ZP	29	23500	Pin, Cotter, 7/64" x 1", ZP
11	25475	Swivel, Hitch	30	16484	Bolt, 3/8-16 x 2-1/2", HCS, ZP
12	22157	Bushing, .386" ID x .623" OD x 1.915"	31	25476	Tongue, TB1 Hitch
13	12337	Bolt, 3/8-16 x 2-3/4", HCS, GR5, ZP	32	26556	Bolt, 1/2-13 x 2-3/4", HCS, ZP
14	11239	Washer, Flat, 3/8", USS, ZP	33	11072	Locknut, 1/2-13
15	11075	Nut, Nylon Lock, 3/8"-16, ZP	34	26552	Extender, Hitch
16	21155	Pin, Snap Safety, 3/8" x 2-3/4"	<u>Items Not Illustrated</u>		
17	21154	Pin, Clevis, 1/2" x 3.5" L, ZP		19165	Strap, Hook and Loop
18	16003	Pin, Hitch Clip, 1/2" to 9/16"		11158	Bolt, 5/16-18 x 1", HCS, GR5, ZP
19	21325	Control Panel	<u>Safety and Information Labels</u>		
20	22223	Switch, Snap-In, Electric Start		22222	Label, Control Panel (Pro and Pro-XL)
				32359	Label, Control Panel (Premier)

Schematic – Tow Bar and Remote Control Panel Assembly

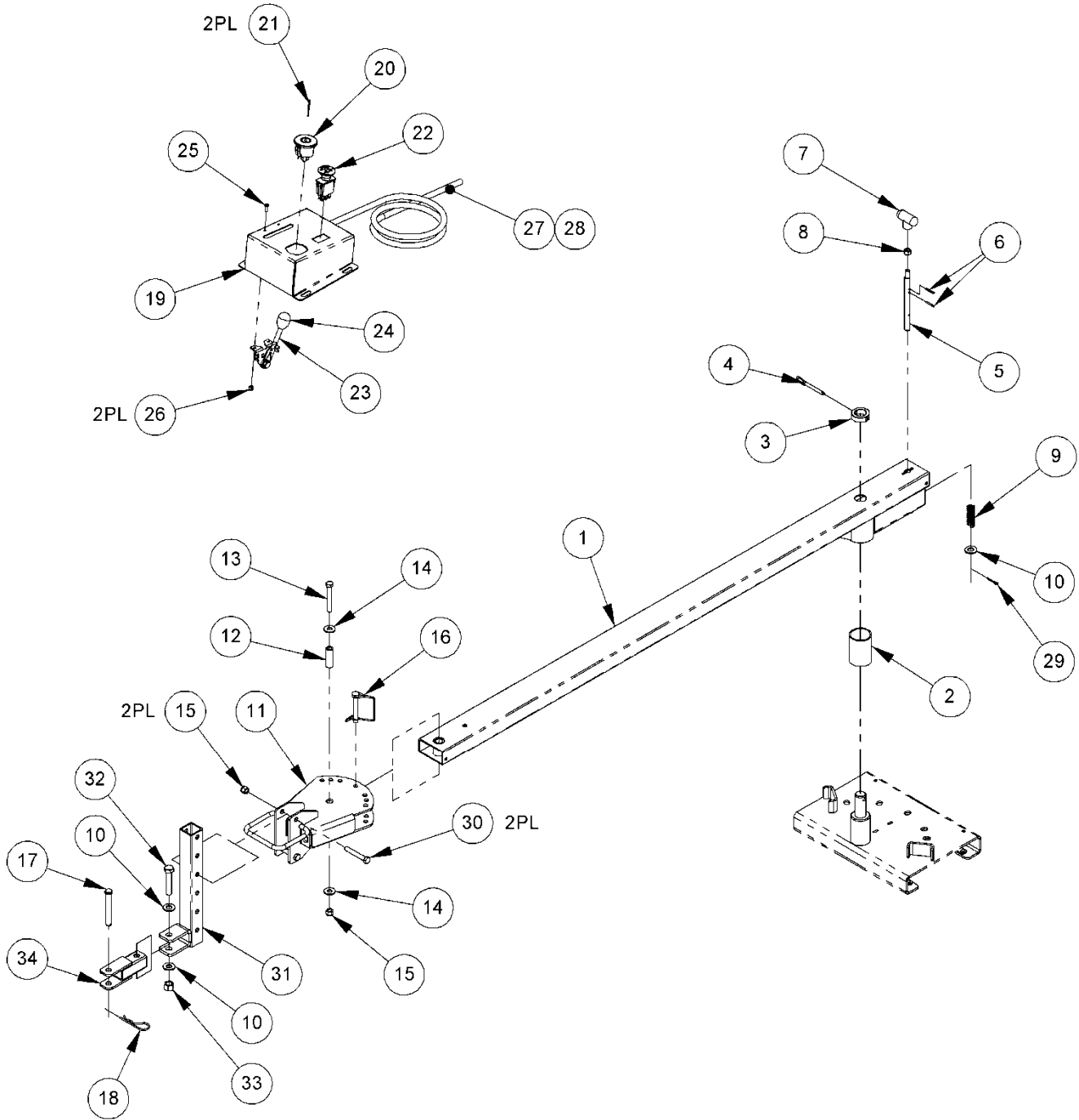

Daily Checklist for the TOW-BEHIND DR FIELD and BRUSH MOWER

To help maintain your **TOW-BEHIND DR FIELD and BRUSH MOWER** for optimum performance, we recommend you follow this checklist each time you use your machine.

WARNING

When performing any adjustment or maintenance, you must first shut off the engine, wait five (5) minutes to allow parts to cool and disconnect the spark plug wire(s), keeping it away from the spark plug(s).

- Check the engine oil and Gas Tank level.
- Check that Engine is clean of debris.
- Check the general condition of the Mower, e.g.; nuts, bolts, welds, etc.
- Check Tire Pressure and wear.
- Check the Frame for wear and damage.
- Check the Blades and Spindle for tightness, nicks, cracks, wear or debris that has wrapped around.
- Check that the Remote Control Panel is secure.
- Check the Debris Guard for wear or damage.

End of Season and Storage

WARNING

When performing any adjustment or maintenance, you must first shut off the engine, wait five (5) minutes to allow parts to cool and disconnect the spark plug wire(s), keeping it away from the spark plug(s).

NOTE: Please refer to the Engine Owner's Manual for Engine-specific procedures.

- Change the Engine oil and Oil Filter and replace the Fuel Filter.
- Remove the Spark Plug(s) and pour about 1 ounce of motor oil into the Cylinder hole. Replace the Plug(s) and crank the Engine over a couple of times using the Electric Starter. This will coat the pistons and seat the valves to prevent moisture buildup.
- Clean or replace the Air Filter(s).
- Clean dirt and debris from the Cylinder Head Cooling Fins, Blower Housing, Debris Screen, and Muffler area of the Engine.
- If your TOW-BEHIND DR FIELD and BRUSH MOWER will be idle for more than 30 days, we recommend using a gas stabilizer. This will prevent sediment from gumming up the Carburetor. If there is dirt or moisture in the gas or tank, remove it by draining the tank. Completely fill the tank with fresh, unleaded gas and add the appropriate amount of stabilizer or gasoline additive. Run the Engine for a short time to allow the additive to circulate.
- Remove any wrapped weeds from the Blades Carrier Housing. Clean grass and debris from the top and underneath the mower Deck with a stiff brush.
- Check the Blades for nicks and wear. Remove the Blades and sharpen them, or have them professionally sharpened if needed.
- Touch-up all rusted or chipped paint surfaces. Sand them lightly before painting.
- Be sure all nuts, bolts, and screws are securely fastened.
- Inspect moving parts and the Blades' Drive Belt for damage and wear; replace if necessary.
- Store the Battery in a dry area that will not freeze. If you will not use the machine over a long period, charge the Battery every four to six weeks.
- If possible, store your TOW-BEHIND DR FIELD and BRUSH MOWER inside, but not near an open flame or spark such as found in a water heater.
- After the TOW-BEHIND DR FIELD and BRUSH MOWER has cooled, cover the machine with a suitable protective cover that does not retain moisture. Do not use plastic as this material cannot breathe; it also allows condensation to form, which will cause your machine to rust.



75 MEIGS ROAD, P.O. BOX 25, VERGENNES, VERMONT 05491