



3pt 60" Plug Aerator

OWNER'S MANUAL



WARNING:

Carefully read and understand all **ASSEMBLY AND OPERATION INSTRUCTIONS** before operating. Failure to follow the safety rules and other basic safety precautions may result in serious personal injury.

Thank you very much for choosing this product! For future reference, please complete the owner's record below:

Serial Number: _____

Order Number: _____

Purchase Date: _____

Save the receipt, the warranty, and these instructions. It is important that you read the entire manual to become familiar with this product before you begin using it.

This product is designed for certain applications only. The manufacturer cannot be responsible for issues arising from modification. We strongly recommend that this product not be modified and/or used for any application other than that for which it was designed. If you have any questions relative to a particular application, DO NOT use the product until you have first contacted us to determine if it can, or should, be performed on the product.

For technical questions, please contact us at www.DRpower.com or call **1-800-DR-OWNER (376-9637)** for assistance.

INTENDED USE

The 60" 3 pt. Plug Aerator is the perfect tool for aerating your compact soil and lawns, allowing nutrients in and keeping your soil and lawns healthy and performing well.

TECHNICAL SPECIFICATIONS

Item	Description
Category	0 and 1
Working Width	60"
Construction	Steel
Dimensions	70.31"x23.23"x31.89"

GENERAL SAFETY RULES



WARNING: Read and understand all instructions. Failure to follow all instructions listed below may result in serious injury.



CAUTION: Do not allow persons to operate or assemble this Plug Aerator until they have read this manual and have developed a thorough understanding of how the Plug Aerator works.



WARNING: The warnings, cautions, and instructions discussed in this instruction manual cannot cover all possible conditions or situations that could occur. It must be understood by the operator that common sense and caution are factors that cannot be built into this product, but must be supplied by the operator.

SAVE THESE INSTRUCTIONS

WORK AREA

- **Keep work area clean**, free of clutter, and well-lit. Cluttered and dark work areas can cause accidents.
- **Keep children and bystanders** away while operating a **Plug Aerator**. Distractions can cause you to lose control, so visitors should remain at a safe distance from the work area.
- **Be alert of your surroundings**. Using a **Plug Aerator** in confined work areas may put you dangerously close to sharp tools and rotating parts.

PERSONAL SAFETY

- **Stay alert**, watch what you are doing, and use common sense when using a **Plug Aerator**. Do not use a **Plug Aerator** while you are tired or under the influence of drugs, alcohol, or medication. A moment of inattention while operating a **Plug Aerator** may result in serious personal injury.
- **Dress properly**. Do not wear loose clothing, dangling objects, or jewelry. Keep your hair, clothing, and gloves away from moving parts. Loose clothes, jewelry, or long hair can be caught in moving parts.
- **Use safety apparel and equipment**. Use safety goggles or safety glasses with side shields that comply with current national standards or, when needed, a face shield. Use a dust mask if working in dusty work conditions. This applies to all persons in the work area. Also use non-skid, safety shoes, hard hats, gloves, dust collection systems, and hearing protection when appropriate.

Plug Aerator USE AND CARE

- **Do not modify the Plug Aerator in any way**. Unauthorized modification may impair the function and/or safety and could affect the life of the equipment. There are specific applications for which the **Plug Aerator** was designed.
- **Always check for damaged or worn-out parts before using the Plug Aerator**. Broken parts will affect the **Plug Aerator's** operation. Replace or repair damaged or worn parts immediately.
- **Do not exceed the Plug Aerator load capacity**.
- **Distribute the load evenly**. Uneven loads may cause the **Plug Aerator** to tip, resulting in personal injury to the operator or others.
- **Use the Plug Aerator on flat and level surfaces** capable of supporting the **Plug Aerator** and its maximum load. Pulling or pushing a load on a slanted or uneven surface can result in loss of control.
- **Store idle Plug Aerator**. When **Plug Aerator** is not in use, store it in a secure place out of the reach of children. Inspect it for good working condition prior to storage and before re-use.

ASSEMBLY INSTRUCTIONS

Step 1: Take away the pointed two hex bolts M8x40 and nylon lock nuts M8, set the two cutter tooth in correct position, then lock them.

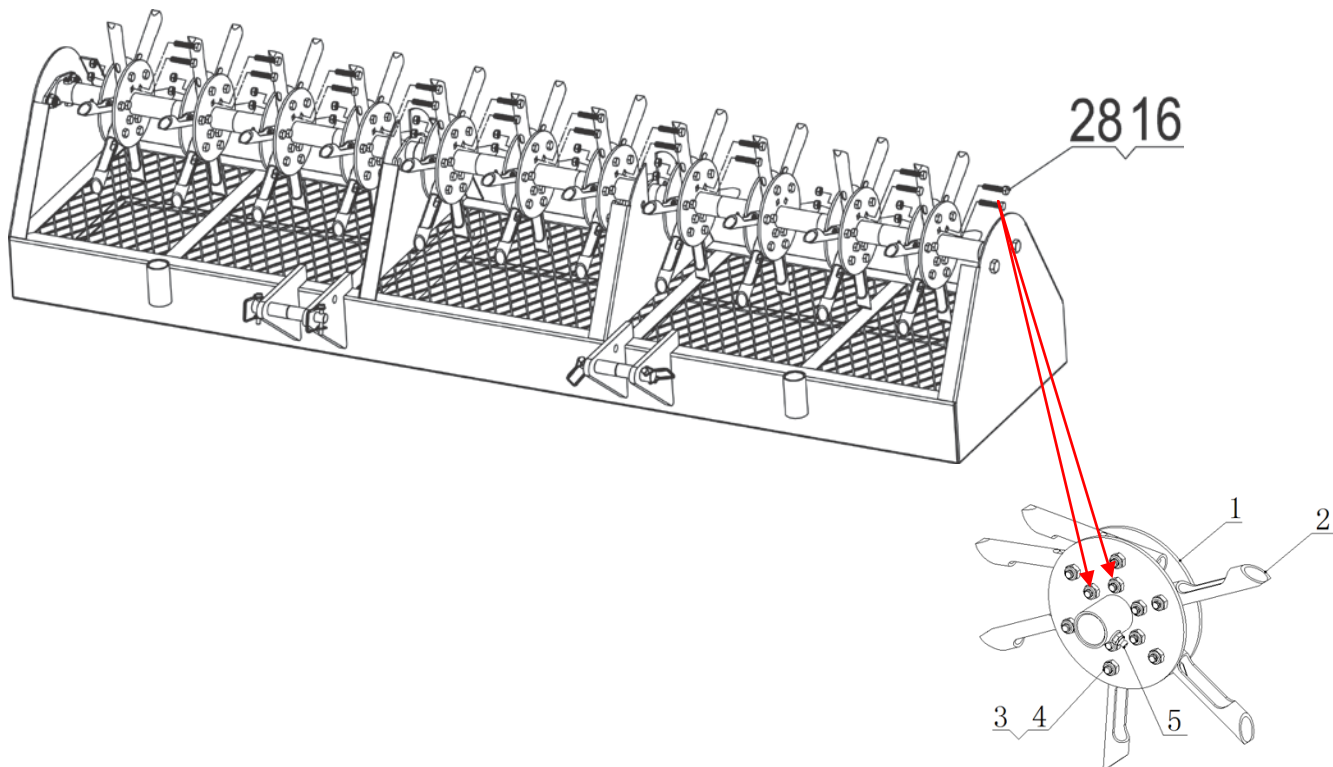

Step 2: Insert drive pin (#7) to the support leg (#8), then insert support leg (#8) to the frame (#1) and tighten with hex bolt M10x45 (#5) and nylon lock nut M10 (#6).

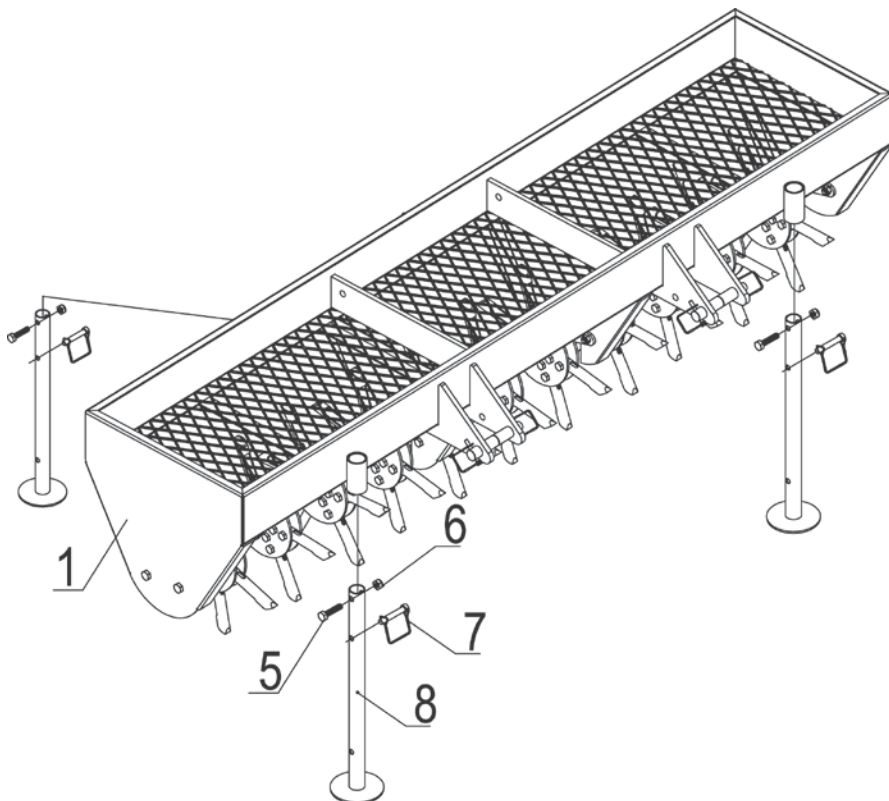

- Step 3:**
1. Attach connecting plate (#23) to the frame (#1) using hex bolt M12x35 (#22), flat washer Ø12 (#12), and nylon lock nut M12 (#13).
 2. Attach tractor connecting plate (#9) to the frame (#1) using hex bolt M12x35 (#22), flat washer Ø12 (#12) and nylon lock nut M12 (#13).
 3. Connect the hex bolt M12x110 (#11) through the connecting plate (#23), tractor connecting plate (#9), stop collar (#10), tractor connecting plate (#9) and connecting plate (#23), then tighten with flat washer Ø12 (#12) and nylon lock nut M12 (#13).
 4. Attach hitch pin II (#24) and hitch pin (#25) through tractor connecting plate (#9), separately insert drive pin (#7) and drive pin (#3).

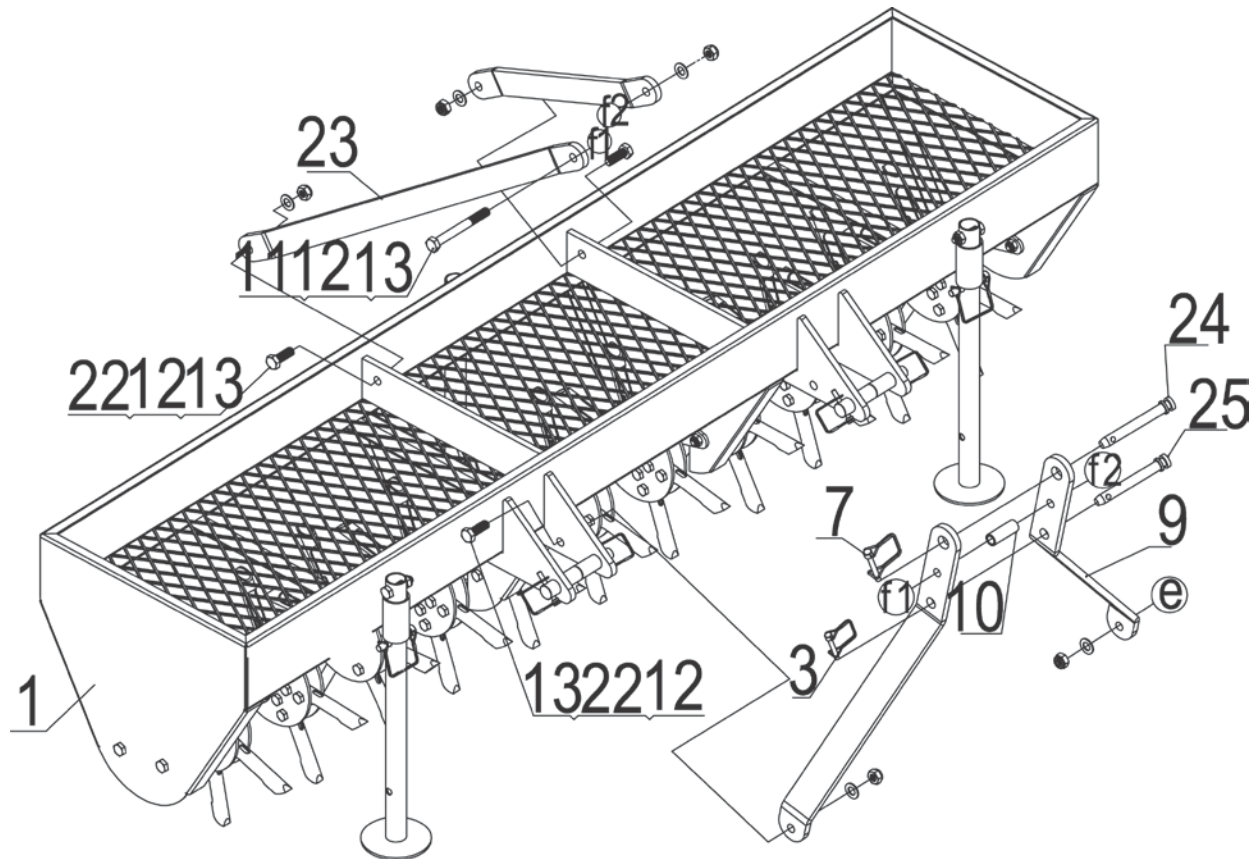

OPERATION

- Connect the aerator to the category 0 or 1 tractor. Lift the aerator. Remove the pins (#7) from the support legs (#8), raise the support legs, and insert pins (#7) back in the raised legs during aerator use.

MAINTENANCE

- **Maintain your Plug Aerator.** It is recommended that the general condition of any **Plug Aerator** be examined before it is used. Keep your **Plug Aerator** in good repair by adopting a program of conscientious repair and maintenance. If any abnormal vibrations or noise occurs, have the problem corrected before further use. Have necessary repairs made by qualified service personnel.

PARTS DIAGRAM

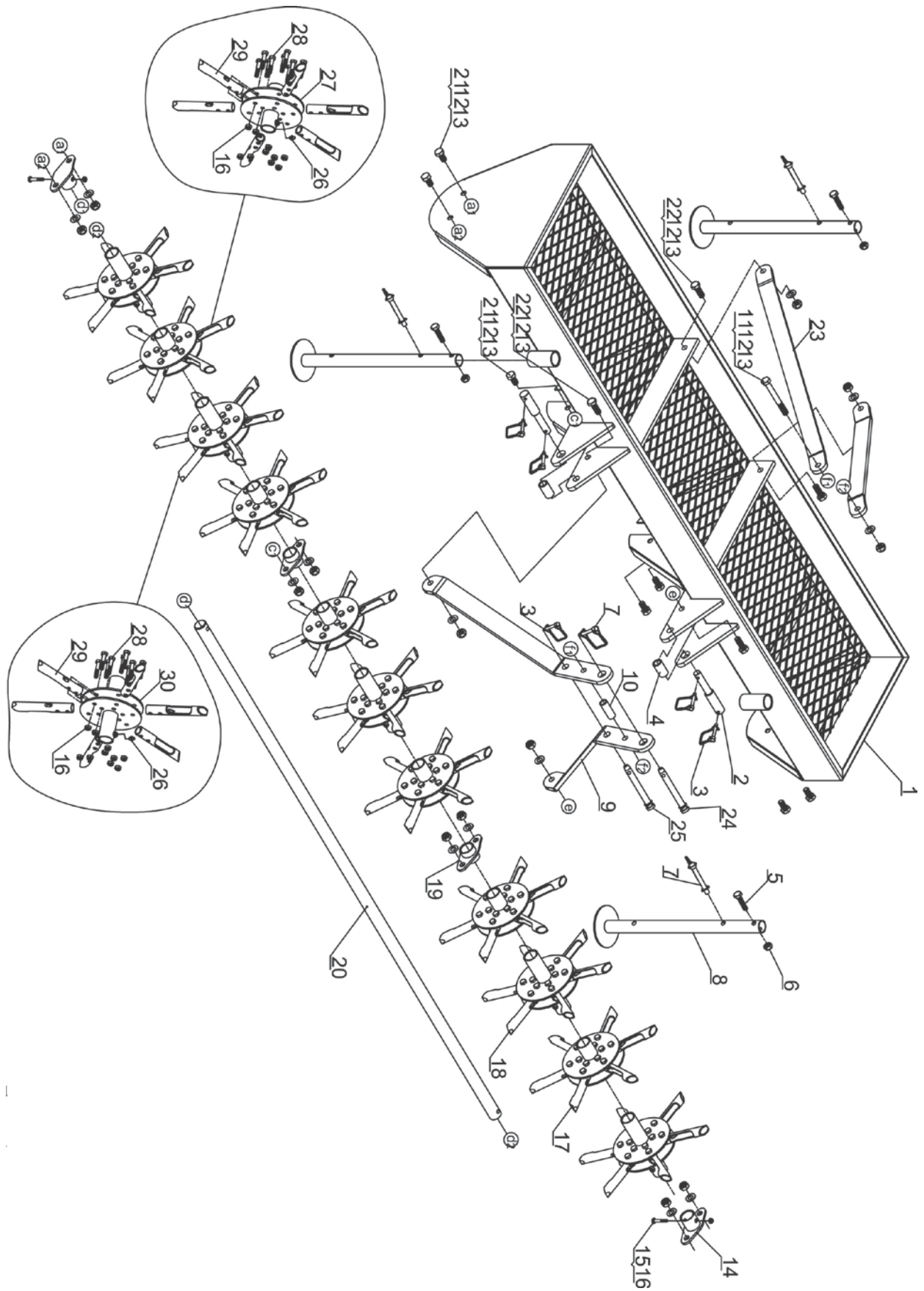

PARTS LIST

Ref#	Description	Part #	Qty.
1	Frame	41240	1
2	Pin Ø22x134	41211	2
3	Drive Pin Ø6x53	41212	5
4	Pin Sleeve	41213	2
5	Hex Bolt M10x45	41214	3
6	Nylon Lock Nut M10	41215	3
7	Drive Pin Ø9x65	41216	4
8	Support Leg	41217	3
9	Tractor Connecting Pin	41218	2
10	Stop Collar	41219	1
11	Hex Bolt M12x110	41220	1
12	Flat Washer Ø12	41221	13
13	Nylon Lock Nut M12	41222	13
14	Guide Block A	41223	2
15	Hex Bolt M8x45	41224	2
16	Nylon Lock Nut M8	41225	134
17	Short Plug Spool Assembly	41226	6
18	Long Plug Spool Assembly	41227	5
19	Guide Block B	41228	2
20	Axle Shaft	41259	1
21	Hex Bolt M12x25	41230	8
22	Hex Bolt M12x35	41231	4
23	Connecting Plate	41232	2
24	Hitch Pin II Ø19x138	41233	1
25	Hitch Pin Ø16x138	41234	1
26	Oil Cup	41235	11
27	Short Plug Spool Weldment	41236	6
28	Hex Bolt M8x40	41237	132
29	Cutter Tooth	41238	66
30	Long Plug Spool Weldment	41239	5

For replacement parts and technical questions, please contact us at www.DRpower.com or call **1-800-DR-OWNER (376-9637)** for assistance

DR[®] 3PT 60" PLUG AERATOR



2-Year Limited Warranty

Terms and Conditions

The DR[®] PLUG AERATOR is warranted for two (2) years against defects in materials or workmanship when put to ordinary and normal consumer use; ninety (90) days for any other use.

For the purposes of all the above warranties, "ordinary and normal consumer use" refers to non-commercial residential use and does not include misuse, accidents or damage due to inadequate maintenance.

DR Power Equipment certifies that the DR[®] PLUG AERATOR is fit for ordinary purposes for which a product of this type is used. DR Power Equipment however, limits the implied warranties of merchantability and fitness in duration to a period of two (2) years in consumer use, ninety (90) days for any other use.

The 2-Year Limited Warranty on the DR[®] PLUG AERATOR starts on the date the machine ships from our factory. The 2-Year Limited Warranty is applicable only to the original owner.

The warranty holder is responsible for the performance of the required maintenance as defined by the manufacturer's owner's manuals. The warranty holder is responsible for replacement of normally wearing parts such as the Cutter Teeth. Accessories to the machine are not covered by this warranty.

During the warranty period, the warranty holder is responsible for the machine transportation charges, if required. During the warranty period, warranty parts will be shipped by standard method at no charge to the warranty holder. Expedited shipping of warranty parts is the responsibility of the warranty holder.

SOME STATES DO NOT ALLOW LIMITATIONS ON THE LENGTH OF IMPLIED WARRANTIES, SO THE ABOVE LIMITATIONS MAY NOT APPLY TO YOU.

DR Power Equipment shall not be liable under any circumstances for any **incidental or consequential damages or expenses** of any kind, including, but not limited to, cost of equipment rentals, loss of profit, or cost of hiring services to perform tasks normally performed by the DR[®] PLUG AERATOR.

SOME STATES DO NOT ALLOW THE EXCLUSION OR LIMITATION OF INCIDENTAL OR CONSEQUENTIAL DAMAGES, SO THE ABOVE LIMITATIONS MAY NOT APPLY TO YOU.

THIS WARRANTY GIVES YOU SPECIFIC LEGAL RIGHTS, AND YOU ALSO HAVE OTHER RIGHTS, WHICH VARY FROM STATE TO STATE.



**75 Meigs Rd, PO Box 25
Vergennes, VT 05491**