

DR CHIPPER

Operating & Assembly Instruction Manual

Model: 10.0 HP

C102-CHP



This manual contains information concerning proper and improper operating procedures, warnings, maintenance, troubleshooting, assembly, and tips. Everyone who operates this machine should read these instructions and be thoroughly familiar with them.

SECTION I – SAFETY



This symbol points out important safety instructions which, if not followed, could endanger the personal safety and/or property of yourself and others. Read and follow all instructions in this manual before attempting to operate your chipper. Failure to comply with these instructions may result in personal injury. When you see this symbol - **heed its warning.**

**THIS MACHINE IS CAPABLE OF INFLICTING SERIOUS INJURY
IF
OPERATED IMPROPERLY -- READ WARNINGS & CAUTION LABELS.**

INTENDED USE

Never use your chipper for any other purpose than chipping limbs. It is designed for this use and any other use many cause serious injury.



DANGER: *Rotating cutting blade.*

Keep hands and feet out of inlet and discharge opening while machine is running.

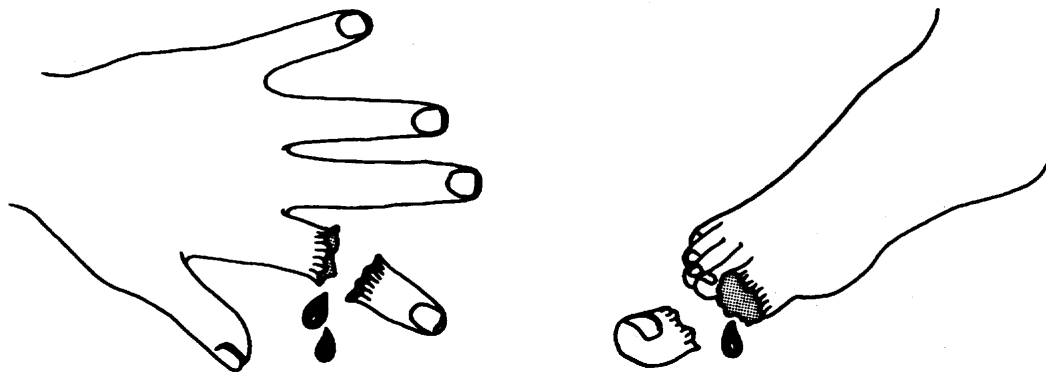

DANGER: This machine can **CRUSH, GRIND, CUT,** and **SEVER** parts of your body if they enter the inlet or discharge area of your chipper.



DANGER: Your chipper was built to be operated according to the rules for safe operation in this manual. **As with any type of power equipment, carelessness or error on the part of the operator can result in serious injury.** If you violate any of these rules, you may cause serious injury to yourself or others.



WARNING: The Engine Exhaust from this product contains chemicals known to the state of California to cause cancer, birth defects or other reproductive harm.

MAKE CERTAIN THAT ALL SAFETY LABELS ON THIS EQUIPMENT ARE KEPT CLEAN AND IN GOOD CONDITION. IF YOU NEED REPLACEMENT LABELS, ORDER BY PART NUMBER.



080-0967



080-0970



091-0055



091-0057



091-0059



091-0062



091-0088



091-0256



091-0380



091-0381

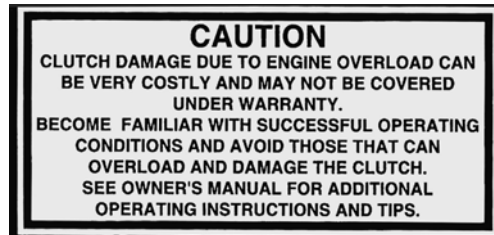

913-0265

SAFE OPERATION PRACTICES

TRAINING

- Read this owner's manual carefully in its entirety before attempting to assemble this machine. Read, understand, and follow all instructions on the machine before operation. Be completely familiar with the controls and the proper use of the machine before operating it. Keep this manual in a safe place for future and regular reference and for ordering replacement parts.
- Never allow children to operate the unit. Never allow adults to operate the equipment without proper instruction. Only responsible individuals who are familiar with these rules of safe operation should be allowed to use your unit.
- Keep the area of operation clear of all persons, particularly small children and pets. Stop the engine when they are in the vicinity of the unit. Keep work area clean and clear of branches or obstacles, which could cause you to stumble or fall.
- Keep in mind that the operator or user is responsible for accidents or hazards occurring to other people, their property, and themselves.
- Your chipper is a powerful tool, not a plaything. Exercise extreme caution at all times. Your unit has been designed to chip. Do not use it for any other purpose.
- If situations occur which are not covered in this manual, use care and good judgment. Contact your place of purchase for additional assistance.

PREPARATION

- Thoroughly inspect the area where the equipment is to be used and remove all foreign objects.
- Do not operate the machine without wearing adequate outer garments and safety goggles. Always wear safety glasses or goggles during operation and while performing any adjustment or repair, to protect eyes from foreign objects that may be thrown from the machine. Be sure your glasses or goggles fit properly.
- Avoid loose-fitting clothes and use protective footwear that will improve footing on slippery surfaces. Shirt and slacks that cover the arms and legs and steel-toed shoes are recommended. Secure hair above shoulders. Do not wear loose clothes or jewelry that can be caught in moving parts. Never operate a unit in bare feet, sandals or sneakers. Wear gloves when feeding material into the chipper chute. Be sure your gloves fit properly and do not have loose cuffs or drawstring.
- Warning: Fuel is highly flammable and the vapors are explosive. Take the following precautions.
 - Store fuel and oil in approved containers.
 - Keep away from heat and open flame, and out of the reach of children.
 - Refuel outdoors only and do not smoke while refueling.
 - Check and add fuel before starting the engine. Never remove gas cap or add fuel while the engine is running or when the engine is hot. Allow engine to cool before refueling.
 - If fuel is spilled, do not attempt to start the engine but move the machine away from the area of spillage and avoid creating any source of ignition until fuel vapors have disappeared.
 - Replace all fuel tank and container caps securely.
 - Never store the machine or fuel container inside where there is an open flame or spark, such as a gas hot water heater, space heater, clothes dryer or furnace.
 - To reduce fire hazard, keep engine and muffler free of debris build-up. Clean up fuel and oil spillage. Allow unit to cool at least five minutes before storing.
- Never attempt to make any adjustments while the engine is running.

OPERATION

- Never place your hands, feet, or any part of your body in the chipper chute, discharge opening, or near or under any moving part while the engine is running. Keep clear of the discharge opening at all times. If it becomes necessary to push material into the chipper chute, use a small diameter stick, NOT YOUR HANDS.
- Keep your face and body back from chipper chute to avoid accidental bounce back of any material.
- The machine should only be operated on a level surface. Never operate your unit on a slippery, wet, muddy, or icy surface.
- Stay alert for hidden hazards or traffic. Do not carry passengers.
- If the cutting mechanism strikes a foreign object or if your machine should start making an unusual noise or vibration, immediately stop the engine, remove the spark plug wire(s) and wait for all moving parts to come to a complete stop. After the machine has come to a complete stop proceed as follows:
 - Inspect for any damage.
 - Repair or replace any damaged parts before restarting and operating the machine.
- Exercise caution to avoid slipping or falling.
- If the machine should start to vibrate abnormally, immediately stop the engine, remove the spark plug wire(s) and wait for all moving parts to come to a complete stop and inspect for the cause. Vibration is generally a warning sign of trouble.
- Stop the engine when leaving the operating position, and when making any repairs, adjustments and inspections.
- Take all possible precautions as recommended by the manufacturer when leaving the machine unattended. Stop the engine and remove the key if so equipped.
- Before cleaning, repairing, or inspecting, shut off the engine and make certain the flywheel and all moving parts have come to a complete stop. Disconnect the spark plug wire and keep the wire away from spark plug to prevent accidental starting. Do not use flammable solutions to clean air filter.
- Never run this machine in an enclosed area as the exhaust from the engine contains carbon monoxide, which is an odorless, tasteless, and deadly poisonous gas.
- Keep all guards and safety devices in place and operating properly. Do not operate the machine if all safety guards are not in place.
- Do not use the unit with the chipper hopper removed.
- The muffler and engine become hot and can cause a severe burn. Do not touch.
- Keep children and pets away.
 - Tragic accidents can occur if the operator is not alert to the presence of small children.
 - Keep children out of the work area and under the watchful eye of a responsible adult other than the operator.
 - Be alert and turn the unit off if a child enters the area.
 - Never allow children to operate the chipper.
- Do not overload or attempt to chip material beyond manufacturers recommendation. Personal injury or damage to the machine could result.
- Never operate the machine at high transport speeds or on hard or slippery surfaces.
- Never allow bystanders near the unit while running.
- Only use accessories approved for this machine by the manufacturer. Read, understand, and follow all the instructions provided with the approved accessory.
- Only operate unit in good daylight. Do not operate unit at night or in dark areas where your vision may be impaired.
- Use extreme caution when reversing or pulling the machine towards you.
- Do not tamper with the engine's governor setting. The governor controls the maximum safe operation speed and protects the engine. Over-speeding the engine is dangerous and will cause damage to the engine and to the other moving parts of the machine. See your authorized dealer for engine governor adjustments.
- Start the engine according to the manufacturers instructions. Keep hands and feet away from inlet and discharge areas.
- Never pick up or carry the machine while the engine is running.
- Do not operate while under the use of alcohol, drugs, or medication. A clear mind is essential for safety.
- Do not allow anyone who is not alert to operate this machine.
- When feeding material into this equipment, be extremely careful that pieces of metal, rocks, or other foreign objects are not included. Personal injury or damage to the machine could result.
- Keep area of discharge clear of people, animals, buildings, glass or anything else that will obstruct clear discharge, cause injury or damage. Wind can also change discharge direction, so be aware.

- Do not allow an accumulation of processed material to build up in the discharge area as this will prevent proper discharge and can result in kick-back from the chipper chute.
- Do not allow any part of the engine, especially around the cooling fans and muffler, to become clogged with processed material, leaves, oil, grease or any other combustible material.
- Do not operate engine if air cleaner or cover over carburetor air-intake is removed, except for adjustment. Removal of such parts could create a fire hazard.

MAINTENANCE AND STORAGE

- Keep machine, attachments and accessories in safe working condition.
- Check engine mounting bolts and other hardware at frequent intervals for proper tightness. Never operate your chipper in poor mechanical condition or when in need of repair. Be sure all safety guards and shields are in proper position. These safety devices are for your protection.
- Never store machine with fuel in the fuel tank inside a building where ignition sources are present, such as hot water and space heaters, clothes dryers and the like. Allow the engine to cool before storing in any enclosure.
- Always refer to the operator's manual for important details if the machine is to be stored for an extended period.
- If the fuel tank is to be drained, do this outdoors.
- Follow the manufacturer's recommendations for safe loading, unloading and storage of machine.
- If it is necessary for any reason to unclog the feed intake or discharge openings or to inspect or repair the machine where a moving part can come in contact with your body or clothing, shut the machine off, allow all moving parts to come to a complete stop disconnect the spark plug wire(s) and allow the engine to cool before attempting to unclog, inspect or repair.
- Check the knife mounting screws at frequent intervals for proper tightness. Also visually inspect the knife for wear or damage. Replace the knife with parts that meet original equipment specifications.
- Knives should be checked for sharpness and the bolts attaching them to the flywheel for tightness every 8-10 hours of operation.
- Replace the nylock nuts securing the knife every time you replace the knife.
- Check the gap between the knife and wear plate every time you sharpen or replace the knife, or every 8-10 hours of operation.
- Never tamper with safety devices. Check their proper operation regularly.
- Inspect the belt each time you use the unit. Look for damage, worn areas or tears. Do not use the unit if this condition exists.
- Do not tamper with the engine's governor setting. The governor controls the maximum safe operation speed and protects the engine. Over-speeding the engine is dangerous and will cause damage to the engine and to the other moving parts of the machine. See your authorized dealer for engine governor adjustments.

**BEFORE STARTING ENGINE
ALWAYS CHECK OIL LEVEL**

- Only operate your chipper from the operator zone.
- Know how to turn your unit off.
- Never move your chipper or leave it unattended with the engine running.
- Follow engine owner's manual for engine maintenance and repair.

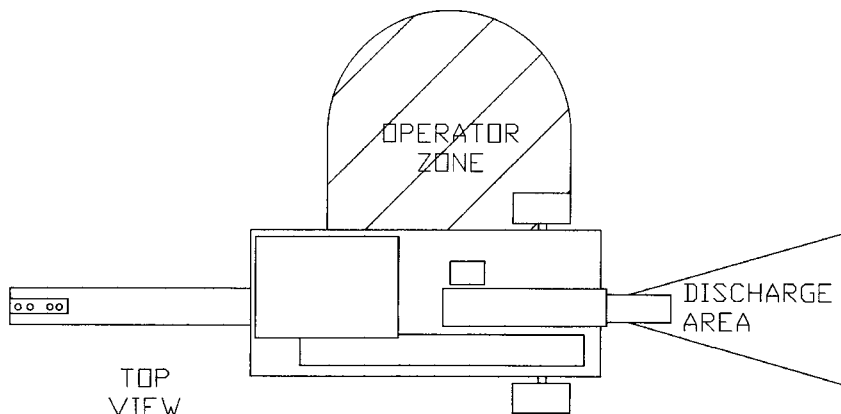

YOUR RESPONSIBILITY

- Restrict the use of this power machine to persons who read, understand and follow the warnings and instructions in this manual and on the machine.

SAVE THESE INSTRUCTION
FOR FUTURE REFERENCE



HAZARD: This unit is equipped with an internal combustion engine and should not be used on or near any unimproved forest-covered, brush-covered or grass-covered land unless the engine's exhaust system is equipped with a spark arrester meeting applicable local or state laws (if any). If a spark arrester is used, the operator should maintain it in effective working order.

In the State of California, the above is required by law (Section 4442 of the California Public Resources Code). Other states may have similar laws. Federal laws apply on federal lands. A spark arrester for the muffler is available through your Briggs & Stratton servicing dealer.

SECTION II - ASSEMBLY INSTRUCTIONS

PACKAGE CONTENTS

SKID	PARTS BOX	BOLT BAG
CHIPPER	CHIPPER HOPPER	4 EA – 5/16-18 X 3/4" CARRIAGE BOLTS
TOW BEAM	HITCH PLATE	3 EA – 5/16-18 X 1" HHCS
PARTS BOX	GLASSES	7 EA – 5/16-18 NYLOCK NUTS
	OWNER'S MANUAL	4 EA – 5/16 USS FLATWASHERS
	ENGINE MANUAL	1 EA – 1/4-20 X 1 1/4" U-BOLT
	BOLT BAG	2 EA – 1/4-20 NYLOCK NUTS
	KNIFE GAUGE	

TOOLS REQUIRED FOR ASSEMBLY

- 1/2" Wrench or Socket - 2 required
- 7/16" Wrench or Socket

STEP I - UNPACKING AND CHECKING CONTENTS

1. Remove the carton and place the unit on its wheels.
2. After unpacking the shipping carton, compare the contents with the list above.
3. If any parts are missing or damaged, contact Country Home Products at 800-376-9637.
4. Assembly should be done on a clean, level surface.

STEP II - UNIT ASSEMBLY INSTRUCTIONS

1. Assemble chipper hopper (item #15, pg 29) to machine using four each 5/16"-18 x 3/4" carriage bolts, 5/16"-18 nylock nuts and 5/16" flatwashers. Put head of bolt inside hopper with threads sticking out. Tighten all hardware with a 1/2" wrench.
2. Attach the tow beam (item #2, pg 27) to the axle of the machine by putting the u-bolt (item #26, pg 27) from the bolt bag around the axle and through the two holes in the tow beam per the picture on page 28. Secure with two 1/4-20 nylock nuts.
3. Attach the center of the tow beam to the front of the frame as shown on page 28 with a 5/16-18 x 1" HHCS and a 5/16-18 nylock nut.
4. Attach the hitch plate (item #3, pg 27) to the tow beam as shown on page 28 with two 5/16-18 x 1" HHCS (item #18, pg 27) and two 5/16-18 nylock nuts (item #19, pg 27).
5. Service the engine as per the engine manual.
6. Lubricate both rotor bearings every 8 hours of operation with multi-purpose grease. Also check the bearing collar set screws regularly to be sure they are tight. If they are loose, reset them with Loctite 243, obtainable at any hardware store.

SECTION III - OPERATION

BEFORE STARTING ENGINE, ALWAYS CHECK OIL LEVEL!

Refer to the engine owner's manual for further details regarding OPERATION AND MAINTENANCE OF the engine.

NOTE: ENGINE IS SHIPPED *WITHOUT* OIL! FILL CRANKCASE WITH OIL BEFORE STARTING ENGINE. BE VERY CAREFUL NOT TO ALLOW DIRT TO ENTER THE ENGINE WHEN CHECKING OR ADDING OIL OR FUEL.

NOTE: IF YOU START THE ENGINE WITHOUT OIL, THE ENGINE WILL BE DAMAGED BEYOND REPAIR AND WILL NOT BE COVERED UNDER WARRANTY.

BEFORE STARTING: Oil and Gas Fill-Up

Oil Capacity: ¾ quarts (26 ounces)

Fuel Capacity: 1 gallon

OIL

- Use a high quality detergent oil classified "For Service SF, SG, SH, SJ" or higher.
- Do not use special additives.
- Choose a viscosity according to the following table.

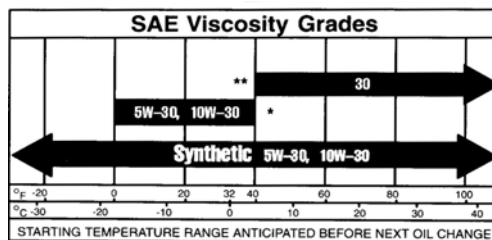

* **CAUTION:** Air cooled engines run hotter than automotive engines. The use of non-synthetic multi-viscosity oils (5W-30, 10W-30, etc.) in temperatures above 40 deg. F (4 deg. C) will result in higher than normal oil consumption. When using a multi-viscosity oil, check oil level more frequently.

** **CAUTION:** SAE 30 oil, if used below 40 deg. F (4 deg. C), will result in hard starting and possible engine bore damage due to inadequate lubrication.

CHECKING AND ADDING OIL

- Check oil level before starting the engine.
- Check level daily, or after every eight hours.
- Keep oil level at FULL.
- Do not overfill.

Oil filling procedure:

- Place engine level and clean around oil fill area.
- Remove oil fill cap.
- Pour oil slowly. Fill to point of overflowing.
- Replace and tighten oil fill cap.

Oil checking procedure: before starting engine, check oil level.

- Place engine level and clean around oil fill area.
- Remove oil fill cap.
- If oil level is not to the top of fill hole add oil.
- Pour oil slowly. Fill to point of overflowing.
- Replace and tighten oil fill cap.

FUEL

- Use clean, fresh, regular unleaded gasoline with a minimum of 85 octane. Fresh fuel prevents gum from forming in the fuel system or on essential carburetor parts. Purchase fuel in quantity that can be used within 30 days.
- Do not use gasoline which contains Methanol.
- Do not mix oil with gasoline.

CAUTION: Some fuels, called oxygenated or reformulated gasoline, are gasoline blended with alcohols or ethers. Excessive amounts of these blends can damage the fuel system or cause performance problems. If any undesirable operating symptoms occur, use gasoline with a lower percentage of alcohol or ether.

ADDING FUEL

- Fill tank outdoors or in a well-ventilated area, away from sparks, open flames, pilot lights, heat and other ignition sources
- If fuel spills, wait until it evaporates before starting engine.
- Turn engine OFF and let engine cool at least 2 minutes before removing gas cap.
- Remove cap. Fill tank to approximately 1-½ inches below top of neck to allow for fuel expansion. Be careful not to overfill.
- Replace cap before starting.

STARTING AND STOPPING

STARTING AND OPERATING TIPS

- Store and fuel equipment in level position.
- Use fresh fuel.
- Use correct type of oil for expected starting temperature.
- Remove external equipment/engine loads.
- Periodically remove any debris buildup from the machine.
- After engine has started, let it warm up several seconds to several minutes, depending on outside temperature.
- For maximum performance and life, operate engine with choke in RUN and throttle in FAST.

TO START ENGINE

- Check oil level.
- Open fuel shut-off valve.
- Move choke control to CHOKE position.
- Move throttle to FAST position. Operate engine with throttle in FAST.
- Grasp rope handle. Pull slowly until resistance is felt, then pull rapidly to start engine and avoid kickback.
- Let engine warm up. Slowly adjust choke control toward RUN position. Wait until engine runs smoothly before each choke adjustment.

TO STOP ENGINE

- Move throttle to SLOW, then to STOP.
- Close fuel shut-off valve.

CAUTION: Do not stop engine by moving choke control to CHOKE. Backfire, fire or engine damage could occur.

Operation Notes

- At engine start-up, the engine of your chipper operates under no load until approximately 1200-1400 RPM'S at which speed the centrifugal clutch engages and begins driving the rotor.
- Proper rotor speed is 2400 RPM +/- 200 RPM.
- When viewed from the operator zone, the flywheel turns in a clockwise direction. This rotation pulls branches into the chipper.
- Always wear protective gloves and safety glasses during operation of the chipper.
- If it becomes necessary to push material into the chipper hopper, only use a wood stick, never your hands or anything steel.
- Never assume you know where the knife is. You don't know where it is. Always keep hands out of the chipper hopper.
- Keep area of discharge clear of people, animals, buildings, glass or anything else that will obstruct clear discharge, cause injury or damage. Wind can also change discharge direction, so be aware.

SECTION IV - CHIPPING

THIS CHIPPER WAS DESIGNED FOR CHIPPING LIMBS OR BRANCHES. NEVER USE THIS MACHINE FOR ANY OTHER PURPOSE AS IT COULD CAUSE SERIOUS INJURY.

SAFETY FIRST

- Always wear protective gloves and safety glasses during operation of the chipper.
- Never allow your hands or any part of your body or clothing inside the chipper hopper or discharge area of the chipper.
- Keep all protective guards and warning labels on the machine and in good working condition.
- Always stand clear of the discharge area when the chipper is running.
- Keep your face and body back from the chipper hopper to avoid being struck by any material that may bounce back.
- Keep proper balance and footing while operating the chipper.
- If it becomes necessary to push material into the chipper hopper, only use a wood stick, never your hands or anything steel.
- Never assume you know where the chipper knife is. You do not know where it is.
- Keep area of discharge clear of people, animals, buildings, glass or anything else that will obstruct clear discharge, cause injury or damage. Wind can also change discharge direction, so be aware.
- Always keep hands out of the chipper hopper.
- Never operate the chipper without the chipper hopper in place.
- Do not transport the chipper while the engine is running.
- Do not refuel the engine while it is hot, warm, or running.
- Do not cover the chipper while the muffler is still hot.

PROCESSING LIMBS OR BRANCHES

- Your chipper can process dry or green material.
- Remove side limbs, branches or twigs from main branch.
- Feed branch into chipper hopper.
- Keep branch at same angle as chipper hopper.
- As the branch becomes short and is inside the chipper hopper, finish processing it by pushing it into the chipper with the next branch.
- If branches are 2" or larger in diameter, feed only one branch at a time into the chipper.
- If branches are smaller than 2", more than one at a time can be fed into the chipper.
- Green branches process quicker and easier than dry branches.
- Soft wood processes easier than hard wood.
- When chipping branches, sometimes a tail will be left at the end of the branch (usually green wood) that will increase in length as you chip. To avoid this, rotate or twist the branch as you feed it into the chute.
- Rotating the branch as you feed it into the machine will improve chipping performance.

- **USE COMMON SENSE WHEN USING YOUR CHIPPER.**
- **LEARN TO RECOGNIZE THE CHANGE IN THE SOUND OF YOUR MACHINE WHEN IT IS OVERLOADED.**
- **BECOME FAMILIAR WITH SUCCESSFUL OPERATING CONDITIONS AND AVOID THOSE THAT CAN OVERLOAD AND DAMAGE THE MACHINE.**
- **IF THE MACHINE BECOMES JAMMED BY OVERLOADING OR ANY OTHER CAUSE, STOP THE MACHINE IMMEDIATELY.**

IF YOU JAM THE MACHINE AND DO NOT STOP THE ENGINE, IT CAN:

- **BURN THE BELT**
- **RUIN THE CLUTCH**

THIS DAMAGE CAN BE COSTLY AND IT MAY NOT BE COVERED UNDER WARRANTY. FOR THIS REASON, IT IS IMPORTANT THAT YOU IMMEDIATELY SHUT OFF THE MACHINE IF IT BECOMES JAMMED.

- **ONLY YOUR OPERATOR EXPERIENCE WILL TELL YOU HOW FAST TO FEED LIMBS.**
- **CHECK TO SEE THAT THE FLYWHEEL WILL TURN FREELY BEFORE YOU START THE CHIPPER.**
- **VISUALLY CHECK CHIPPER KNIFE FOR DAMAGE EACH TIME YOU USE YOUR CHIPPER.**
- **CHECK KNIFE CONDITION, WEAR PLATE CONDITION, GAP SETTING AND THE NUTS AND BOLTS THAT HOLD THE KNIFE IN PLACE FOR TIGHTNESS EVERY 8-10 HOURS OF OPERATION.**
- **DO NOT ALLOW CHIPS TO BUILD UP WITHIN 3" OF DISCHARGE CHUTE OPENING. MOVE CHIPPER OR PILE AS NEEDED. FAILURE TO DO THIS COULD RESULT IN UNNECESSARY JAMMING OF THE MACHINE.**
- **TO MOVE PILE OF PROCESSED MATERIAL, USE SPADE, RAKE, OR LONG HANDLE TOOL. NEVER USE YOUR HANDS OR FEET!**

TO FREE A JAMMED FLYWHEEL

- Stop the engine.
- Remove the spark plug wire and keep away from the spark plug.
- Disconnect battery at negative terminal (if so equipped).
- Remove any material left in the chipper hopper.
- Remove the deflector.

NOTE: Never pry against the scroll weldment when removing the deflector or at any other time. This will cause damage to the machine.

- Check to see if deflector is clogged. If it is, clear with a branch.
- With a wooden stick, loosen and remove any material left in the chipping chamber.
- Reinstall the deflector.
- Reconnect the spark plug wire and battery (if so equipped).
- Start machine and let material in chipping chamber discharge through deflector.
- If chamber doesn't clear and the flywheel is still jammed, repeat above process.
- Be certain chipping chamber is clear before trying to process more material into the chipper.

SECTION V - MAINTENANCE AND STORAGE

IMPORTANT: The knife should be checked for sharpness and the bolts attaching them to the flywheel for tightness every 8-10 hours of operation.

IMPORTANT: Every time you perform maintenance or any kind of service or check on the knife, be sure to check the gap between the knife and wear plate for proper setting.

NOTE: A knife gauge has been provided with your machine. It is 1/16th thick and should be used to set the correct gap between the knife and wear plate.

If the cutting mechanism strikes any foreign object or if your machine should start making an unusual noise or is vibrating, stop the engine, disconnect the spark plug wire from the spark plug. Allow the engine to cool before you:

- a. Inspect and examine for damage.
- b. Repair or replace any damaged parts before restarting and operating the machine.

1. When not in use, your chipper should be stored out of the reach of children. Be sure there are no gasoline fumes in the storage area. For long periods of storage (over winter), refer to the engine owner's manual.
2. After every 8 hours of operation, lubricate the chipper side and drive side bearings. To do this, wipe all dirt, etc., from the grease fittings with a clean cloth, then apply no more than 3 shots of quality general-purpose grease with a hand-pumped grease gun. Over lubrication can also damage bearings. Also, check the bearing collar set screws regularly to be sure they are tight. If they are loose, reset them with Loctite 243, obtainable at any hardware store.
3. You will find information included referring to operation and maintenance of the chipper engine. Look it over carefully. **BE CERTAIN TO SERVICE THE ENGINE BEFORE YOU START IT.**
4. When the steel chipping knife (item #8, pg. 29) needs replacing or sharpening, refer to the section on removal, sharpening and re-installation.
5. Care must be exercised when sharpening the knife to maintain the correct bevel and a straight edge. Refer to sharpening directions. When you install a knife, use the supplied knife gauge to be sure the clearance between the knife and wear plate is set to 1/16" (see figure 1).
6. To adjust this clearance, loosen the three 1/4" nuts and bolts (item #11 & #20, pg. 29) holding the wear plate in place. The wear plate can now be slid up or down (in or out) to achieve the correct gap setting.
7. Take the knife gauge and slide between the knife and wear plate. If the gap is set correctly, the knife gauge will lightly touch both the knife and wear plate. If the gap is too small, you will not be able to get the gauge between the knife and wear plate. If the gap is too large, there will be excess room between the knife gauge, knife and wear plate. Tighten the nuts and bolts when the wear plate is in the correct position. Be certain the flywheel rotates without hitting anything before starting the chipper.
8. If the gap between the wear plate and the knife is not set correctly, you will have excessive vibration when chipping and the blade will seem to be dull. This should be checked every 8-10 hours of operation.
9. If at any time it becomes necessary to disassemble the chipper for repairs, the chipper disk (item #3, pg. 29) must be re-installed in exactly the same position on the rotor shaft.

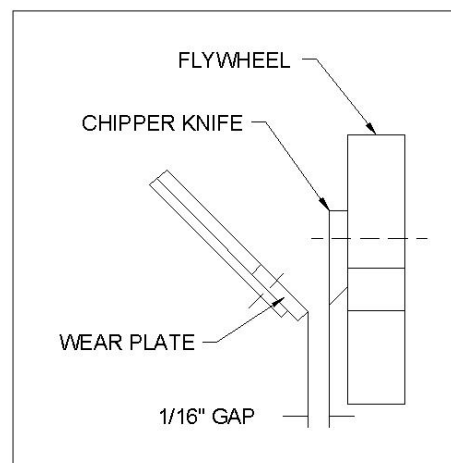

NOTE: Proper gap setting is critical to the proper operation of your machine.

REMOVAL, SHARPENING AND RE-INSTALLATION OF CHIPPER KNIFE

HOW TO REMOVE THE KNIFE

- Stop the engine.
- Remove the spark plug wire and keep away from the spark plug.
- Disconnect battery at negative terminal (if so equipped).
- Open the access cover on the chipper basic machine.
- Rotate the chipper disk until the three countersunk screws attaching the knife to the flywheel are visible through the access door.
- Clean out the heads of the allen screws with an awl or sharp tool.
- Insert a 3/16" allen wrench into the heads of the screws.
- While applying pressure with the allen wrench, apply heat from a propane torch to the screws to break loose the Loctite on the screws.
- Remove the heat once the screws have loosened.
- Remove all three allen screws in this manner.

KNIFE SHARPENING

- You should never attempt to sharpen the chipper knife (or knives) freehand.
- It is extremely important that the 45 degree angle be maintained consistently for proper performance.
- The chipper knife (or knives) should be taken to a machine shop for proper sharpening.
- If your chipper is equipped with two knives, it is extremely important that they be balanced to equal weights to eliminate vibration.
- If your chipper is equipped with two knives, replace in pairs only.
- Excessive heat generated during the sharpening process will damage knives and weaken the metal. **Be sure the knives are not overheated.**

KNIFE INFORMATION

- The chipper knife should be checked routinely for sharpness.
- Using a dull knife (knives) will decrease performance and cause excessive vibration that will cause damage to the chipper.
- How many times a knife can be sharpened is determined by how much material needs to be taken off to sharpen or to compensate for dents or gouges.
- A new chipper knife has 5/16" measurement between the short side bevel edge and the knife mounting holes. See figure 2.

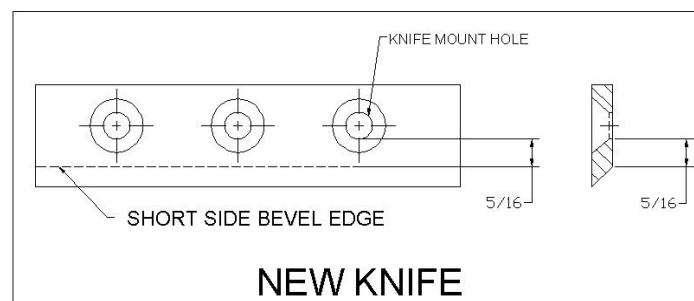

Figure 2

- The knife should never be sharpened to the extent that more than $3/32$ " is taken off this measurement.
- Once this measurement is below $7/32$ " (see figure 3) the knife should be replaced.
- If you are unable to remove dents or gouges with these guidelines, replace the knife.

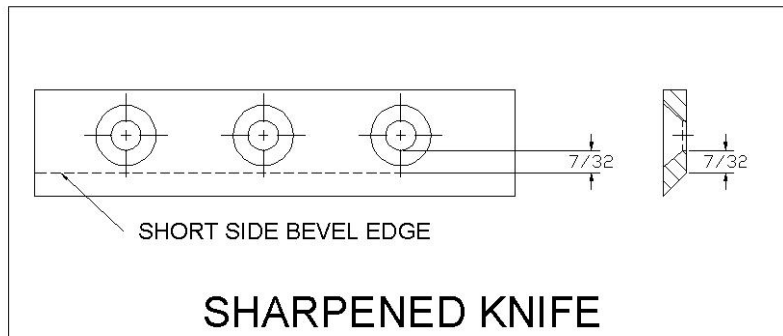

Figure 3

KNIFE INSTALLATION

- Clean chipper disk where knife is going to be attached.
- Visually inspect the chipper disk slot and knife mounting area and be sure they are clean and that the knife will be able to mount flush against the chipper disk.
- Visually inspect and clean the knife.
- Apply Loctite 243 to the screws that hold the knife in place.
- Hand tighten the knife to the chipper disk. If you are installing a new knife, use the new hardware that comes with the knife when attaching it to the chipper disk.
- Tighten the center nut and bolt.
- Tighten the outer nut and bolt.
- Tighten the inner nut and bolt.
- Double check all three for tightness one more time.
- If your chipper has two knives, rotate the flywheel 180 degrees and repeat above process.

WEAR PLATE

- The wear plate should have a square edge and be free of dents or gouges.
- The wear plate can be sharpened by hand, but as with the knife, do not overheat during the sharpening process. This will change the characteristics of the steel and it should be replaced.
- Check the gap between the knife and wear plate every time any adjustments are done to either piece, or every 8-10 hours of operation.

AFTER ANY BLADE OR WEAR PLATE MAINTENANCE OR ADJUSTMENT, ROTATE THE CHIPPER DISK BY HAND. WATCH AND LISTEN CAREFULLY FOR ANY UNUSUAL NOISES, CLICKING OR VIBRATION. IF ANY OF THESE ARE DETECTED, INSPECT THE MACHINE FOR DAMAGE, REPAIR OR REPLACE ANY DAMAGED PARTS AND CHECK FOR ANY LOOSE PARTS AND RETIGHTEN.

KNIVES MUST BE CHECKED AND MAINTAINED!

KNIVES MUST BE SHARP!

BE SURE TO REINSTALL THE KNIFE CORRECTLY AND DOUBLE CHECK FOR TIGHTNESS!

CHANGING OIL

- Your chipper is equipped with an oil drain valve to make changing the oil easy.
- The valve is located on the engine, on the towing side of the machine.
- Place engine level.
- Disconnect spark plug wire and keep it away from spark plug.
- With engine OFF but still warm open oil drain valve and drain oil into appropriate receptacle.
Note: To open valve, push in and turn counterclockwise.
- Close oil drain valve.
- Remove dipstick (if equipped) or oil fill cap.
- Add new oil (26 ounces). Fill to FULL line on dipstick or to point of overflowing at oil fill cap. **Do not overfill.**
- Replace dipstick or oil fill cap.

INSTRUCTIONS FOR ADJUSTING OR REPLACING BELT

BELT ADJUSTMENT

The belt on your chipper should deflect $3/8$ " under three pounds of pressure as shown in figure 1 below. If it doesn't, adjust per the following directions.

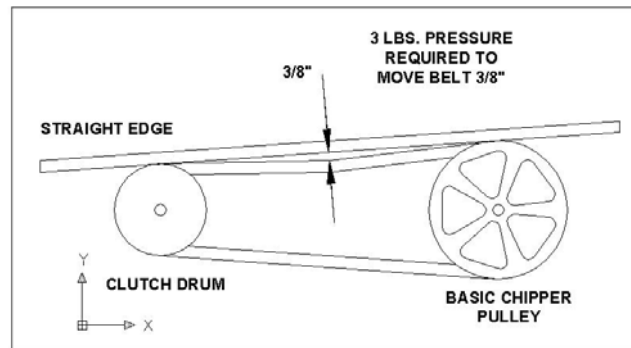

Figure 1

- Remove belt guard.
- Loosen engine bolts.
- Tighten or loosen the nut on the belt tensioner until you have the correct tension as shown in figure 1.
- Retighten engine bolts.
- Check alignment of the clutch (item #12, pg.27) with the drive pulley (item #13, pg 27) by placing a straightedge across both faces as shown in figure 2. If adjustment is necessary, correct alignment by moving rotor pulley in or out on the rotor shaft. **Do not make adjustment by moving the clutch on the engine shaft.**
- Replace belt guard.

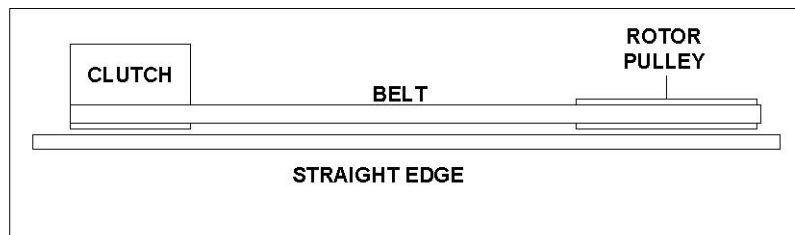

Figure 2

BELT REPLACEMENT

- To replace the belt, follow the above belt adjustment directions.
- After you have loosened the engine bolts, remove the old belt and replace it with a new one.
- Set belt tension and alignment per above directions.

NOTE: Check and re-tighten belt after initial break-in period, one hour of use.

CENTRIFUGAL CLUTCH TECH TIPS

CLUTCH PART NO. 030-0164

THE SHOES AND SPRINGS ON THE CLUTCH ARE NORMAL WEAR ITEMS. IF YOU NOTICE DECREASED PERFORMANCE OF THE CLUTCH THEY SHOULD BE CHECKED AND REPLACED IF NECESSARY.

The clutch on your machine is designed for rugged, dependable service, however, it is important to understand the limitations of a clutch. A clutch is designed to provide load free starting of the engine, and slippage under excessive overloading of the driven application. These features help protect the engine from damages such as broken crankshafts and starters.

The clutch obtains its power from engine RPM's. The lower the engagement speed, and the higher the maintained engine speed, the more torque the clutch can transfer to the driven unit. **Do not operate at less than full RPM's.**

- At engine start-up, the engine of your chipper operates under no load until approximately 1000-1200 RPM'S at which speed the centrifugal clutch engages and begins driving the rotor.
- Proper rotor speed is 2400 RPM +/- 200 RPM.
- Do not tamper with the engine's governor setting. The governor controls the maximum safe operation speed and protects the engine. Over-speeding the engine is dangerous and will cause damage to the engine and to the other moving parts of the machine. See your authorized dealer for engine governor adjustments.
- Become familiar with successful operating conditions and avoid those that can overload and damage the machine.
- Do not overload or attempt to chip material beyond manufacturers recommendation. Personal injury or damage to the machine could result.
- Learn to recognize the sound of the machine when it is overloaded.
- If the machine becomes jammed by overloading or any other cause, stop the machine immediately.
- If you jam the machine and do not stop the engine, it can:
 - Burn the belt.
 - Ruin the clutch.
- Only your operator experience will tell you how fast you can successfully feed limbs into the machine.
- **Clutch damage can be costly and it may not be covered under warranty. For this reason, it is important that you immediately shut off the machine if it becomes jammed.**

CLUTCH MAINTENANCE

The centrifugal clutch on this machine is permanently lubricated and does not require oil or grease. If, after long periods of use, the drum wobbles excessively, replace the drum assembly. Always replace shoes and springs in sets. Whenever shoes are changed, replace all springs.

CLUTCH REMOVAL

1. Remove clutch from shaft by removing bolt and washers.
2. Slide clutch off shaft.
3. Remove key from keyway.

DISASSEMBLY OF EXISTING CLUTCH

1. Remove retainer ring and slide off drum assembly.
2. Unhook one spring from its shoe. Use tape wrapped pliers to avoid nicking spring.
3. Carefully note position of shoes. Remove shoes from hub.

REASSEMBLE

1. Locate shoes correctly on hub for rotation required.
2. Place one end of each spring over a shoe pin, stretch spring just enough to clear pin on the other shoe. Use tape wrapped pliers to avoid nicking spring. Avoid over stretching that may damage spring. Repeat for all shoes.
3. Replace washer on hub shaft.
4. Reassemble drum to hub, secure with retaining ring.
5. Locate key in keyway of hub.
6. Slide clutch onto crankshaft, then washers.
7. Secure hub by tightening cap screw and allen head set screws.

INSTALLATION OF A NEW CLUTCH

1. Clean shaft and remove any burrs.
2. Apply anti-seize compound to the shaft.
3. Place key in keyway on shaft.
4. Slide clutch onto shaft, secure with bolt, flatwasher and lockwasher (items #21, 22 & 23).
5. Tighten two allen head set screws..

030-0164 CLUTCH BREAKDOWN

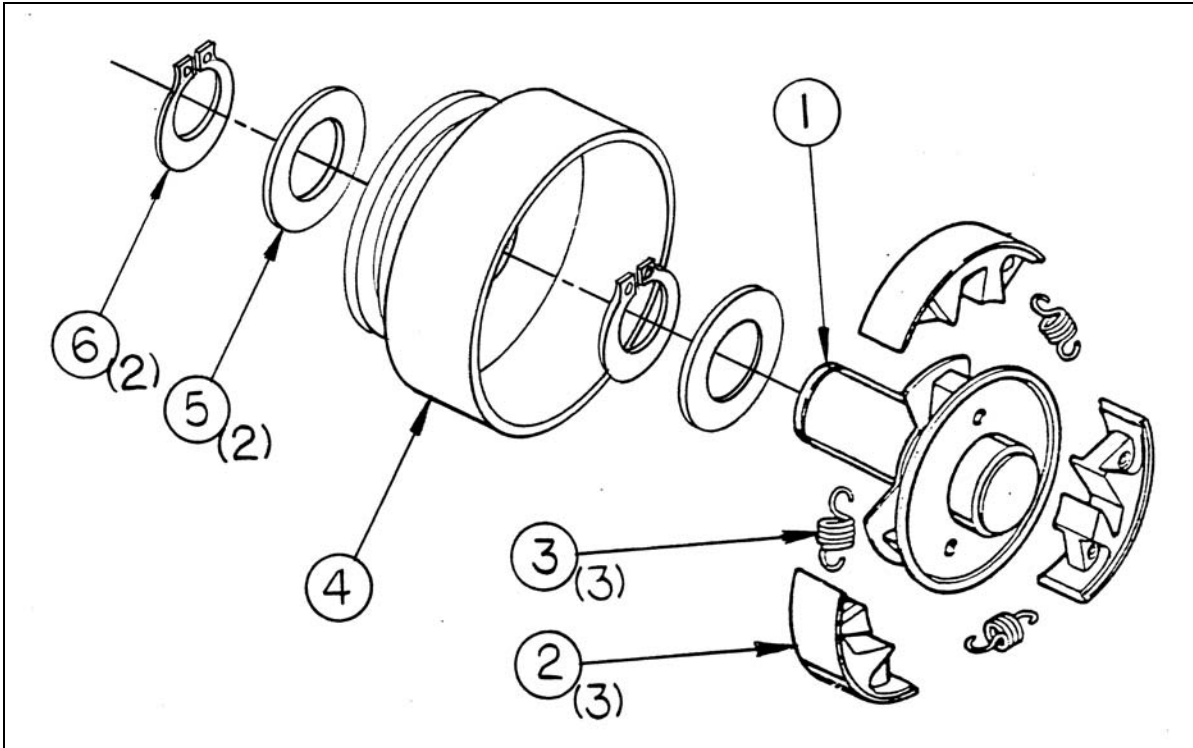

<u>Item</u>	<u>Part No.</u>	<u>Qty</u>	<u>Description</u>
1	030-0164-1	1	Hub Assembly
2	030-0164-2	3	Shoe
3	030-0164-3	3	Spring
4	030-0164-4	1	Drum Assembly
5	030-0164-5	2	Washer
6	030-0164-6	2	Retaining Ring

TROUBLESHOOTING

SYMPTOM	PROBLEM	CORRECTION
Clutch overheats. Belt burns. Flywheel won't turn.	Clutch is slipping or flywheel is jammed or stopped.	<ul style="list-style-type: none"> • Immediately stop engine. • Remove spark plug wires. • Turn flywheel by hand to be sure it turns freely. • Check belt tension.
Chipping action seems too slow or flywheel stalling.	Engine speed is too slow. Belts are slipping.	<ul style="list-style-type: none"> • Run engine at full throttle. • Check for loose or missing belt & tighten.
When chipping, log seems to vibrate excessively & "hammers" hands.	Knife is dull. Gap between knife & wear plate is too great.	<ul style="list-style-type: none"> • Remove knife & sharpen - be sure to maintain same bevel of 45 degrees. • Adjust gap as per instructions.
Chipper knife is hitting wear plate.	The gap between the knife and wear plate is set incorrectly.	<ul style="list-style-type: none"> • Adjust gap per directions in the front of this section.
Engine runs but flywheel doesn't rotate.	Inner shoes of clutch worn. Retaining springs weak or broken. Loose drive belt.	<ul style="list-style-type: none"> • Replace worn or broken clutch parts. • Check belt tension. • Clear chipper chamber.

LUBRICATION AND MAINTENANCE

OPERATION TIME	PROCEDURE	COMMENTS
BREAK IN	<ul style="list-style-type: none"> • Change engine oil and filter after first five hours. • Check belt tension. • Check all nuts and bolts for tightness. 	<ul style="list-style-type: none"> • Follow oil recommendations per the engine & owner's manual. • Adjust per directions. • Tighten if necessary.
8 HOURS	<ul style="list-style-type: none"> • Check engine oil. • Check chipper knife for sharpness. • Check knife and wear plate gap. • Clean air filter. • Grease bearings on basic chipper. * 	<ul style="list-style-type: none"> • Per recommendations. Do not overfill. • See knife information. • See gap setting information. • Per engine recommendations. • Use quality general-purpose grease.
40 HOURS	<ul style="list-style-type: none"> • Change engine oil. ** • Check tire pressure. • Remove and sharpen or replace chipper knife. • Sharpen wear plate. 	<ul style="list-style-type: none"> • Per recommendations. Do not overfill. • Add or adjust as required. • See knife information. • See wear plate information.
100 HOURS	<ul style="list-style-type: none"> • Replace belt. • Change engine oil. 	<ul style="list-style-type: none"> • Order replacement belts. • Per recommendations. Do not overfill.
200 HOURS	<ul style="list-style-type: none"> • Change engine oil filter. • Clean and adjust, or replace spark plugs. 	<ul style="list-style-type: none"> • Per recommendations in engine manual. • Per recommendations in engine manual.

* No more than three pumps of a hand-pumped grease gun. Do not over-grease as this may damage the bearing seal.

** Lubrication schedule may vary depending on working environment. Overly dirty and dusty situations will require more frequent oil changes to protect the engine.

C102-CHP PARTS LIST

ITEM #	PART #	QTY	DESCRIPTION
1	913-0335	1	FRAME WELDMENT
2	913-0089	1	TOW BEAM
3	913-0008	1	HITCH PLATE
4	913-0090	1	AXLE
5	908-0060	2	AXLE BRACKET
6	703-0108	2	TIRES
7	090-0457	2	PUSH CAP
8	913-0011	1	BASIC CHIPPER MACHINE
9	913-0023	1	DEFLECTOR
10	030-0258	1	10 HP BRIGGS & STRATTON ENGINE
11	913-0343	1	BELT TIGHTENER
12	030-0164	1	CLUTCH
13	030-0229	1	PULLEY
14	030-0354	1	5H580 BELT
15	913-0096	1	BELT GUARD ASSEMBLY
16	500-0012	2	TIRE SPACERS
17	080-0081	2	1/4 X 1/4 X 1 1/4" KEY
18	090-0088	11	5/16-18 X 1" HHCS
19	090-0460	19	5/16-18 NYLOCK NUT
20	090-0072	4	5/16-18 X 2" HHCS
21	090-0021	1	3/8-24 x 1 1/4" HHCS
22	090-0228	1	3/8 LOCKWASHER
23	704-0106	1	WASHER
24	090-0233	16	5/16 USS FLATWASHER
25	080-0053	2	5/16-18 X 5/16 SET SCREW
26	090-0610	1	1/4-20 X 1 1/4" U-BOLT
27	090-0077	2	5/16-18 x 4" HHCS
28	030-0387	1	OIL DRAIN VALVE
29	030-0388	1	1/4" X 3" NPT NIPPLE
30	030-0389	1	3/8" TO 1/4" NPT REDOUCCING COUPLING

**CHECK OIL LEVEL
BEFORE STARTING CHIPPER**

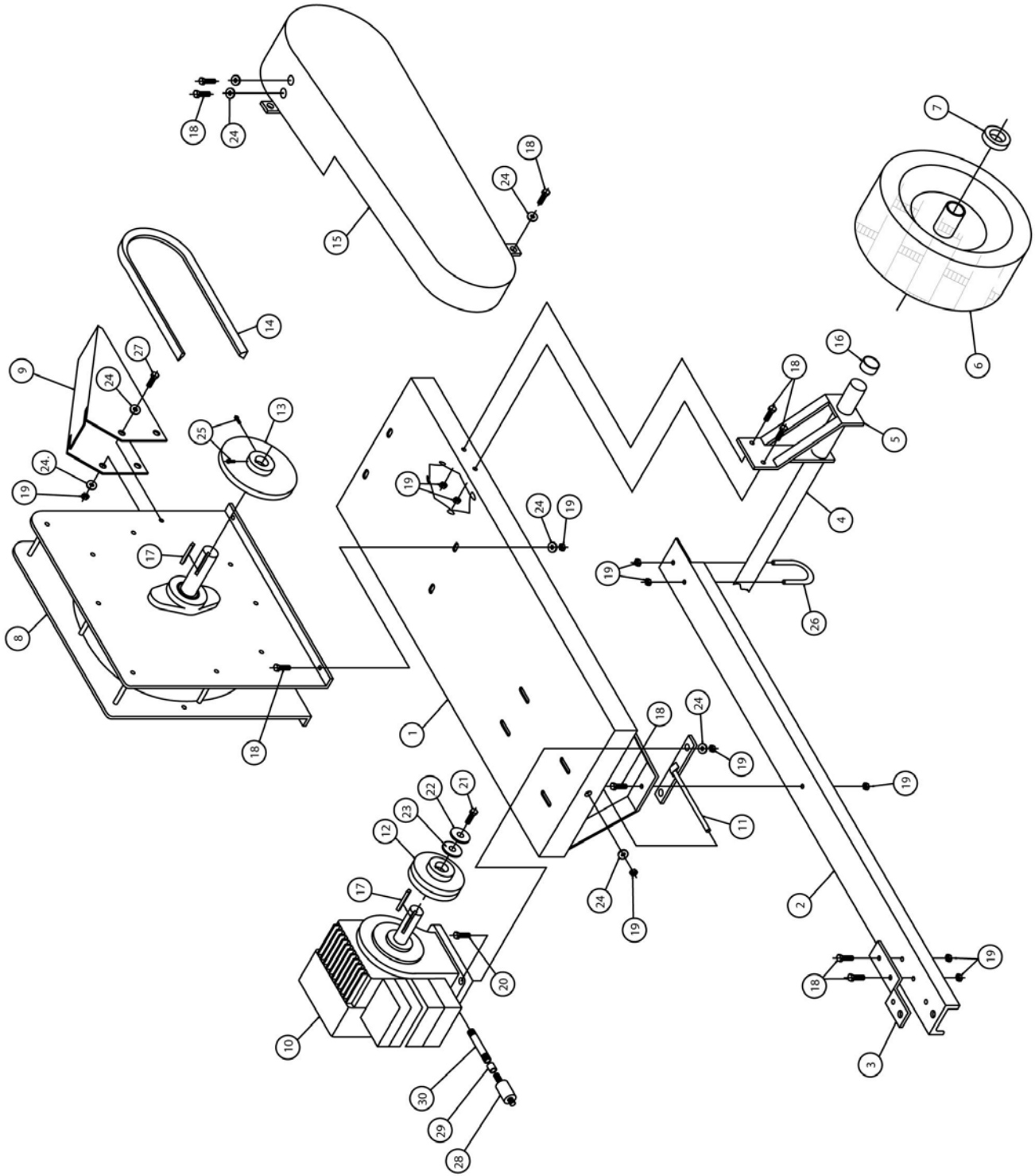

PARTS BREAKDOWN
C102-CHP

913-0011 CHIPPER BASIC MACHINE PARTS LIST

ITEM NO.	QTY.	PART NO.	DESCRIPTION
1	1	913-0012	DRIVE SIDE PLATE WELDMENT
2	9	090-0048	5/16-18 GRIPCO NUT
3	1	900-0243	CHIPPER DISC
4	1	030-0118	FLYWHEEL TAPERLOCK
6	1	913-0334	FLYWHEEL SHAFT
7	1	913-0019	SCROLL WELDMENT
8	1	030-0351	KNIFE
9	3	090-0258	5/16-18 X 3/4" FSHCS
10	2	913-0021	SCROLL TUBE
11	3	090-0677	1/4-20 X 1" CARRIAGE BOLT
12	1	913-0325	WEAR PLATE
13	4	090-0460	5/16-18 NYLOCK NUT
14	8	090-0233	5/16 USS FLATWASHER
15	1	913-0371	CHIPPER HOPPER
16	4	090-0462	5/16-18 X 3/4' CARRIAGE BOLT
17	9	090-0077	5/16-18 X 4" HHCS
18	3	090-0245	1/4 SAE FLATWASHER
19	4	090-0111	3/8-16 X 1 1/4" HHCS
20	3	090-0470	1/4-20 NYLOCK NUT
21	4	090-0042	3/8-16 GRIPCO NUT
22	2	030-0115	SHAFT BEARING
23	2	090-0162	10-32 X 3/8 SELF TAPPING SCREW
24	1	913-0013	CHIPPER SIDE PLATE WELDMENT
25	2	090-0024	SHIM
26	1	030-0117	RETAINING RING
27	2	090-0676	RETAINING RING
28	1	913-0377	BLOW BACK SHIELD
29	3	090-0504	10-24 X 1/2" HHCS
30	3	090-0643	10-24 U-CLIP

ACCESSORIES FOR C102-CHP

Tow beam stand	Order part #	913-0071
Tow handle kit	Order part #	913-0066
All weather cover	Order part #	913-0069

CHECK OIL LEVEL BEFORE STARTING CHIPPER

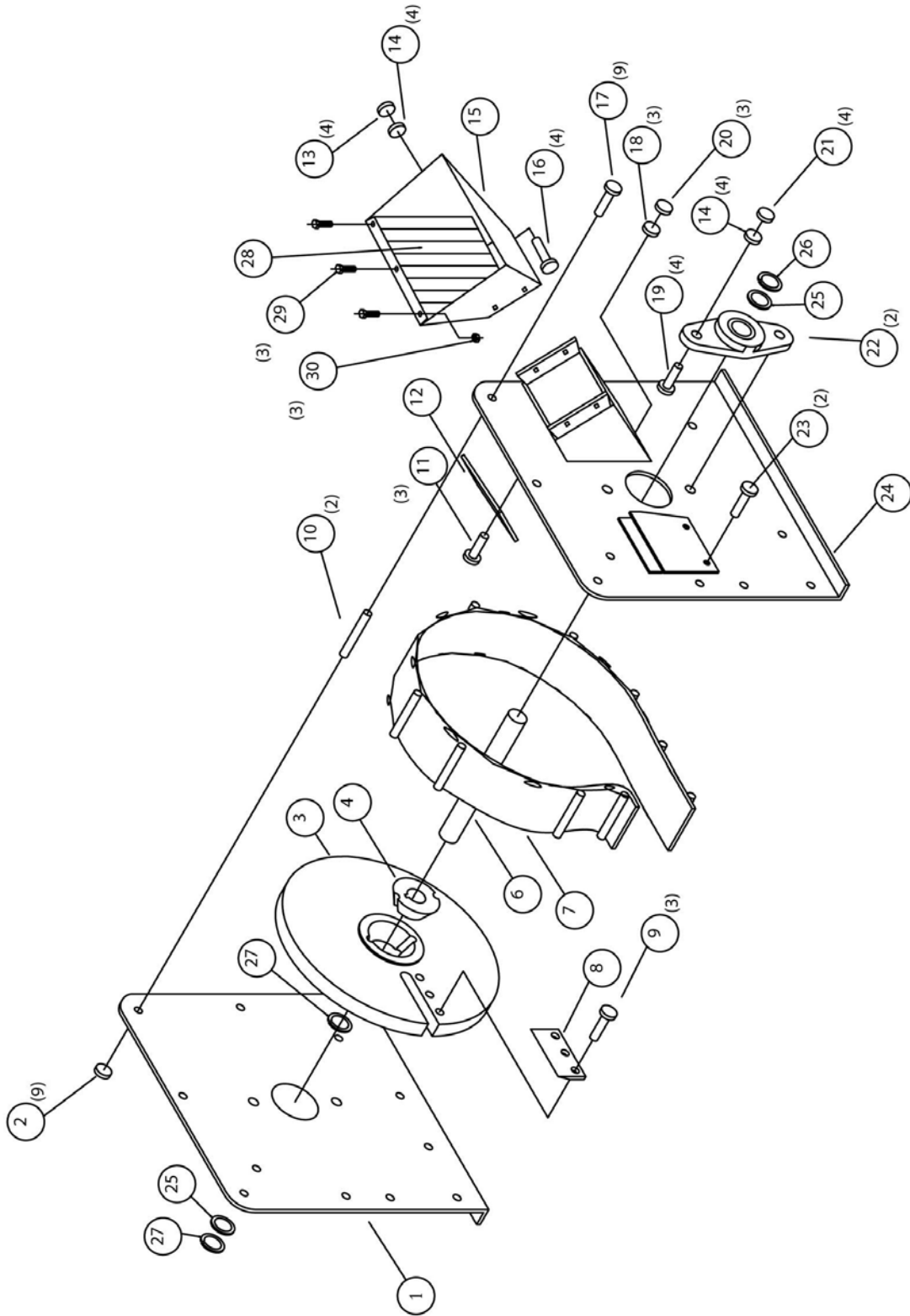

PARTS BREAKDOWN
 913-0011 CHIPPER BASIC MACHINE

NOTES

NOTES

COUNTRY HOME PRODUCTS
Meigs Road, P.O. Box 25, Vergennes, Vermont 05491
1(800)DR-OWNER(376-9637)

©2001 CHP INC. 148281

CODE#31045X

02/02/04