



Pole Saw

Safety & Operating Instructions

Model: CPS40108DR



NEUTON® Power Equipment

75 MEIGS ROAD
P.O. Box 25
VERGENNES, VT 05491



Toll-free phone: **1-866-NEUTON1 (638-8661)**

Fax: 1-802-877-1213

Website: www.neutonpower.com

E-MAIL: INFO@NEUTONPOWER.COM

! WARNING

Read and understand this manual and all instructions before operating the POLE SAW.

Table of Contents

Chapter 1: Important Safety Considerations	3
Chapter 2: Setting Up Your NEUTON Pole Saw	6
Chapter 3: Operating The NEUTON Pole Saw	10
Chapter 4: Maintaining The NEUTON Pole Saw	14
Chapter 5: Troubleshooting	20
Chapter 6: Parts Lists, Schematic Diagrams And Warranty	21

Conventions used in this manual

DANGER

This indicates a hazardous situation, which, if not followed, *will* result in death or serious injury.

WARNING

This indicates a hazardous situation, which, if not avoided, *could* result in death or serious injury.

CAUTION

This indicates a hazardous situation, which, if not avoided, *could* result in minor or moderate injury.

NOTICE

This information is important in the proper use of your machine. Failure to follow this instruction could result in damage to your machine or property.

Additional Information and Potential Changes

Neuton Inc. reserves the right to discontinue, change, and improve its products at any time without notice or obligation to the purchaser. The descriptions and specifications contained in this manual were in effect at printing. Equipment described within this manual may be optional. Some illustrations may not be applicable to your machine.

Chapter 1: Important Safety Considerations

WARNING

Read this safety & operating Instructions manual before you use the NEUTON Pole Saw. Become familiar with the operation and service recommendations to ensure the best performance from your machine. If you have any questions or need assistance, please contact us at www.neutonpower.com or call toll-free 1-866-NEUTON1 (638-8661) and one of our Technical Support Representatives will be happy to help you.

Labels

Your NEUTON Pole Saw carries safety and information labels as a reminder for its proper and safe use. Shown are copies of the labels or tags that appear on the equipment. Take a moment to study them and make a note of their location on your Saw as you set up and before you operate the unit. Replace damaged or missing safety and information labels immediately.



#271561



#271581

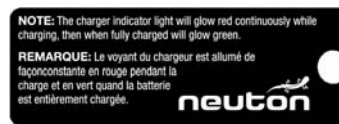

#271591



#271601



#271611

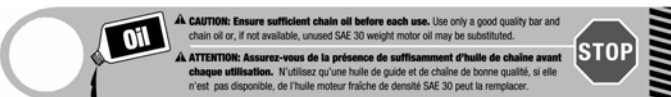

#271571

Protecting Yourself and Those Around You

WARNING

This is a Battery-powered machine, with rotating Teeth operating with high energy. You must operate the machine safely. Unsafe operation can create a number of hazards for you, as well as anyone else in the nearby area. Always take the following precautions when using this machine:

- Keep in mind that the operator or user is responsible for accidents or hazards occurring to other people, their property, and themselves.
- Wear safety glasses with side shields or goggles that are marked to comply with ANSI Z87.1 standard when operating this product. Use face or dust mask if operation is dusty.
- Wear a safety hard hat with a full face shield that meets the ANSI Standards ANSI Z89.1 or CE Standards while operating the pole saw.
- Wear appropriate personal hearing protection during use. Under some conditions and duration of use, noise from this product may contribute to hearing loss.
- Avoid wearing loose clothing or jewelry and wear protective hair covering to contain long hair. They can be caught in moving parts.
- We recommend wearing rubber grip gloves while using the Pole Saw. Be sure your gloves fit properly and do not have loose cuffs or drawstrings.
- Wear shoes with non-slip treads when using your Saw. If you have safety shoes, we recommend wearing them. Do not use the machine while barefoot or wearing open sandals.
- Wear long pants while operating the Machine.
- Keep bystanders 50 feet away from your work area at all times. Stop the Saw when another person or pet approaches.

Hazardous environments

DANGER

- Do not operate pole saw in gaseous or explosive atmospheres. Motors in these tools normally spark, and the sparks might ignite fumes.
 - If pole saw jams on any electrical cord or line, DO NOT TOUCH THE BAR AND CHAIN! THEY CAN BECOME ELECTRICALLY LIVE AND VERY DANGEROUS. Release the unit in the safest manner possible. Disconnect the damaged electrical cord or line from the power source. If possible, do so safely. If in doubt, call an electrician or an electrical contractor for assistance. Failure to heed this Danger will result in serious personal injury and possible death.
 - Use of this tool may cause exposure to chemicals that are known to the state of California to cause cancer, birth defects or other reproductive harm. Dust and debris created during cutting, drilling, grinding or sanding on some materials may contain chemicals known to the State of California to cause cancer or birth defects or other reproductive harm. To reduce exposure to these chemicals, always use approved safety equipment, work in a well-ventilated area and wear dusk mask that filters out microscopic particles.
 - To protect yourself from electrocution maintain a min. of 50ft (15m) from overhead electrical lines.
-

Safety for Children and Pets

WARNING

Tragic accidents can occur if the operator is not alert to the presence of children and pets. Children are often attracted to the machine and the Sawing activity. *Never* assume that children will remain where you last saw them. Always follow these precautions:

- Keep children and pets at least 50 feet away from the working area and ensure they are under the watchful care of a responsible adult.
 - Be alert and release the throttle if children or pets enter the work area.
-

General Safety

WARNING

Operating this Pole Saw safely is necessary to prevent or minimize the risk of death or serious injury. Unsafe operation can create a number of hazards for you. Always take the following precautions when operating this Pole Saw:

- Before any use, be sure everyone using this tool reads and understands all safety instructions and other information contained in this manual.
 - Your Saw is a wood-cutting tool, not a plaything. Exercise extreme caution at all times. The machine is designed to limb trees. Do not use it for any other purpose.
 - Never operate your unit on a slippery, wet, muddy, or icy surface. Exercise caution to avoid slipping or falling.
 - Never use the machine without ensuring that all guards and shields are in place.
 - Never, under any conditions, remove, bend, cut, fit, weld, or otherwise alter standard parts on the Saw. This includes all shields and guards. Modifications to your machine could cause personal injuries and property damage and will void your warranty.
 - If the machine should start making an unusual noise or vibration, stop using it, then inspect for damage. Vibration is generally a warning of trouble. Check for damaged parts and clean, repair and/or replace as necessary.
 - Never tamper with safety devices. Check their proper operation regularly.
 - Don't use pole saws in rain, damp or wet locations.
 - Risk of cut. Keep hands away from chain. Keep both hands securely on pole and handle when operating the Saw.
 - Never stand under the limb being trimmed. Position yourself out of the way of falling debris
 - Stop the motor, wait for the blade to stop, wait five minutes for the saw to cool, remove the battery and wear gloves to protect your hands from the chain teeth before performing any maintenance, inspection or cleaning on the saw. Do not leave Saw unattended.
 - Don't carry the pole saw with finger on switch. Be sure switch is off when installing battery pack.
 - When not in use, pole saw should be stored indoors in a dry and high or locked-up place, out of reach of children.
-

WARNING

- Before further use of the pole saw, any part that is damaged should be carefully checked to determine that it will operate properly and perform its intended function. Check for alignment of moving parts, binding of moving parts, breakage of parts, mounting and any other condition that may affect its operation. A guard or other part that is damaged should be properly repaired or replaced by an authorized service center unless otherwise indicated elsewhere in this manual.
 - Only operate pole saw in daylight or good artificial light.
 - Chain coasts after Pole saw is turn off.
 - Keep cutters sharp and clean for best performance and to reduce the risk of injury. Inspect your Battery periodically and replace if damaged. Keep handles dry, clean and free from oil and grease.
 - Don't force pole saw – It will do the job better and with less likelihood of a risk of injury at the rate for which it was designed.
 - Stay alert – Watch what you are doing Use common sense Do not operate pole saw when you are tired or under the influence of medication, drugs or alcohol.
 - Never carry pole saw with one hand. Doing so could cause saw to become unbalanced and damage may occur. Failure to heed this warning can result in serious personal injury.
 - Do not attempt to remove cut material or hold material to be cut when chain is moving. Make sure Battery is removed when clearing jammed material from Teeth. Do not grasp the exposed Bar or Teeth when picking up or holding the saw.
 - Don't overreach. Keep proper footing and balance at all times.
-

Handling the Battery Pack Safely

WARNING

- Always charge the Battery Pack indoors, never charge it the rain or in wet conditions.
 - Use only the Charger provided to charge the Battery Pack. Use of a different Charger may cause a fire or explosion.
 - Never attempt to alter or open the Battery Pack or Charger. There are no customer serviceable parts inside. Use normal household voltage (120 volts) when charging the Battery Pack. Plug the Charger Power Supply directly into the electrical outlet.
 - Exercise care in handling the Battery Pack in order not to short-circuit it with conducting materials such as rings, bracelets, and keys. When short-circuited, the Battery Pack or conductor may overheat and cause burns.
 - Never dispose of the Battery Pack in a fire, as the Battery Pack may explode. Never open or mutilate the Battery Pack; released electrolyte is corrosive and will cause damage to eyes, skin, or clothes. Battery Pack electrolyte is toxic if swallowed or if you inhale the fumes.
 - A small leakage of liquid from the Battery Pack may occur under extreme usage, charging, or temperature conditions. This does not indicate a failure. However, if the outer seal is broken and this leakage gets on your skin, wash quickly with soap and water and neutralize with a mild acid such as lemon juice or vinegar. If the Battery Pack liquid gets in your eyes, flush them with clean water for a minimum of 10 minutes and seek immediate medical attention.
 - Please dispose of your used Battery Packs responsibly by recycling them, never throw away used Battery Packs in your household trash. Call your local Solid Waste Management District or your local waste handler to locate the collection site nearest you. Some collection sites recycle Battery Packs year-round; others collect them periodically.
-

A Note to All Users

No list of warnings and cautions can be all-inclusive. If situations occur that are not covered by this manual, the operator must apply common sense and operate this NEUTON Pole Saw in a safe manner. Contact us at www.neutonpower.com or call **1-866-NEUTON1 (638-8661)** for assistance.

Chapter 2: Setting Up Your NEUTON Pole Saw

It may be helpful to familiarize yourself with the controls and features of your NEUTON Pole Saw as shown in *Figure 1* before beginning these procedures. If you have any questions at all, please feel free to contact us at www.neutonpower.com.

NEUTON Pole Saw Controls and Features

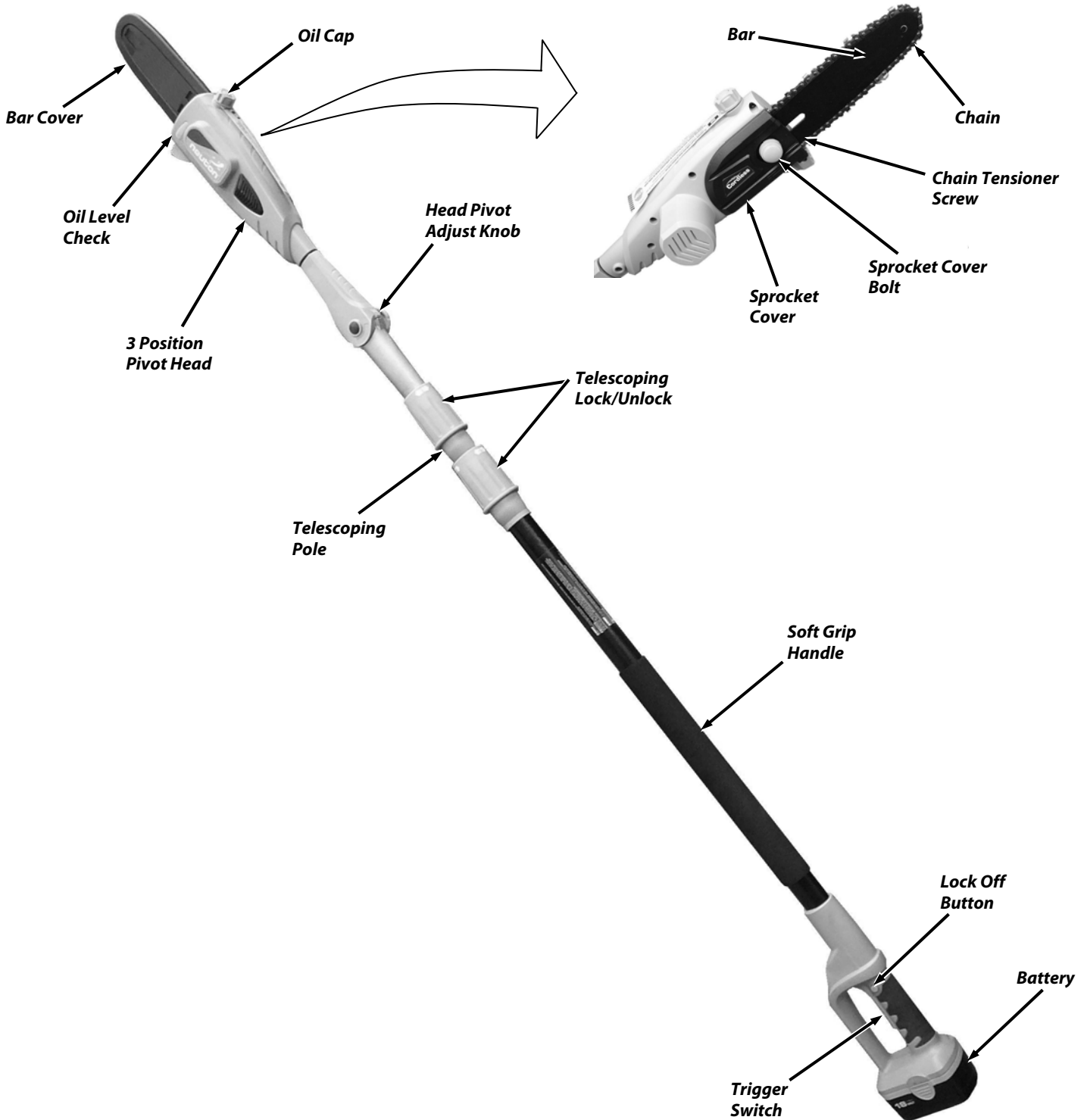

Figure 1

Specifications

Battery 18 Volts
 Bar Length 8"
 Pole Saw Length (before extending) 6'-6.5"
 Pole Saw Length (after extending) 9'
 Pole Saw Weight w/Battery 9 lbs.

Unpacking and assembling the NEUTON Pole Saw

Unpacking

Tools Needed:

- Utility Knife

1. Place the Shipping Box in a clean level area.
2. Cut the Box open with the Utility Knife and remove the contents.

Compare the contents of the Shipping Box with the "Parts Supplied" list below. If you have any questions, please contact us at www.neutonpower.com or call 1-866-NEUTON1 (638-8661) for assistance.

PARTS SUPPLIED

Description	Quantity
Pole Saw Body	1
Bar	1
Chain	1
Sprocket Cover	1
Bolt for Sprocket Cover	1
Battery Pack	1
Battery Charger	1
Spanner Wrench	1

NOTE: Do not discard the Shipping Carton and packaging material until you are fully satisfied with your new NEUTON Pole Saw.

Assembling

Tools Needed:

- Spanner Wrench (supplied with Saw)
- Gloves

1. Lay out the Saw Chain in a loop and straighten any kinks. The sharp side of the Teeth should face in the direction of the Chain rotation (**Figure 2**). If they face backwards, turn the loop over.
2. Place the Chain Drive Links into the Bar groove.

NOTE: Make certain of the direction of Chain.

3. Position the Chain so there is a loop at the back of the bar. Hold the chain in position on the Bar and place the loop around the Sprocket (**Figure 3**).
4. Fit the Bar flush against the mounting surface so that the Bar slot mounts onto the slot flange in the head.

NOTE: When placing the Bar on the flange, ensure that the Tensioner pin is in the Chain Tensioner Pin Hole in the Bar. Adjust the Chain Tensioner Pin as needed by adjusting the Chain Tensioner with a Flat Tip Screwdriver.

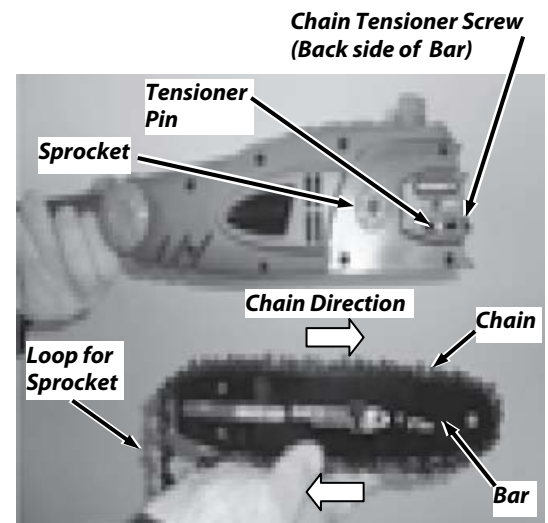

Figure 2

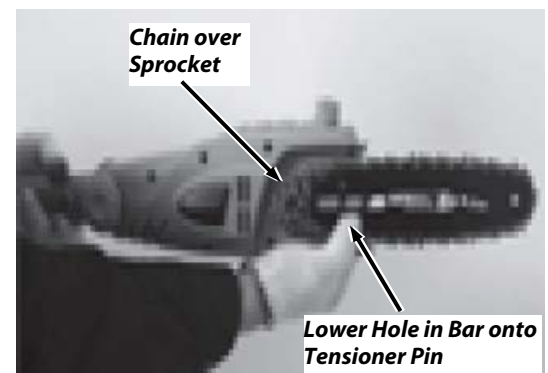

Figure 3

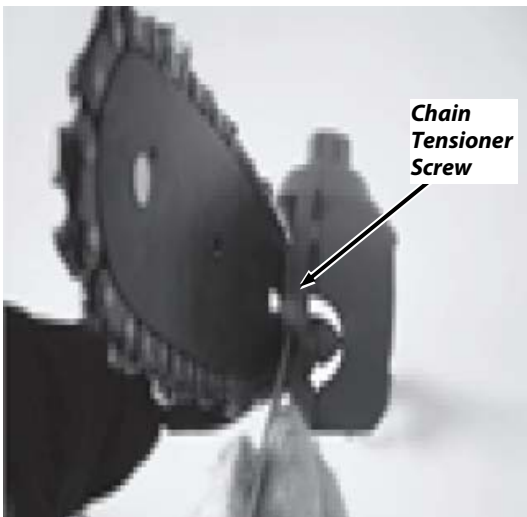

Figure 4

5. Tighten the Chain Tensioner Screw only enough to hold the Bar and Chain in Place (**Figure 4**).
6. Install the Sprocket Cover by inserting the rear tab first and positioning the Cover onto the Bar Stud (**Figure 5**).
7. Install the Sprocket Cover Bolt by hand and leave the Bar free to move for tension adjustment.
8. Remove all slack from the Chain by turning the Chain Tensioner Screw clockwise until the Chain seats snugly against the bar with the drive links in the Bar groove.
9. Tighten the Sprocket Cover Bolt.

NOTE: A cold chain will be correctly tensioned when there is no slack on the underside of the guide bar, the chain is snug, but it can be turned by hand without binding.

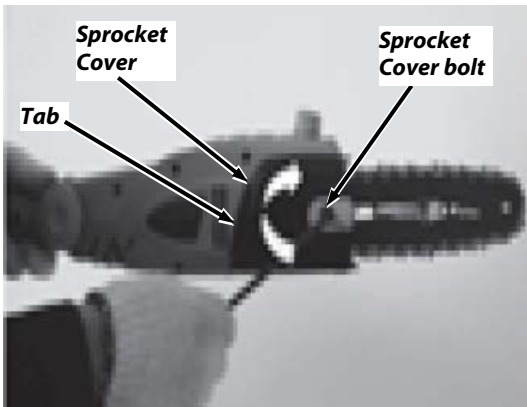

Figure 5

Charge the Battery Pack before your first use

The NEUTON Pole Saw comes with a sealed, Nickel-Cadmium Battery Pack. The Battery Pack is 18 volts and rated at 1.7 amp-hours. The Battery Pack should not leak, regardless of the position in which it is stored. Read "Handling the Battery Safely" in Chapter 1 for additional information. The Battery Pack is completely maintenance free. You never need to add water. With all rechargeable Batteries, after years of use, they will eventually need replacement.

You **MUST** charge the Battery Pack for at least five (5) to six (6) hours before you use the Saw for the first time. If you do not charge it before using the Saw, the Battery Pack's charging capacity may decrease. It may take up to 5 initial charging/discharging cycles before maximum run time/capacity is achieved.

1. Plug the Charger Power Supply into a standard household electrical outlet (**Figure 6**)
2. Place Battery Pack in the Charger. The Battery Pack and Charger have keyways so they will fit together only one way. When properly connected, the RED Charger Indicator Light (LED) will glow

NOTE: The Charger Indicator Light will glow RED continuously while charging. When fully charged the LED light will glow GREEN.

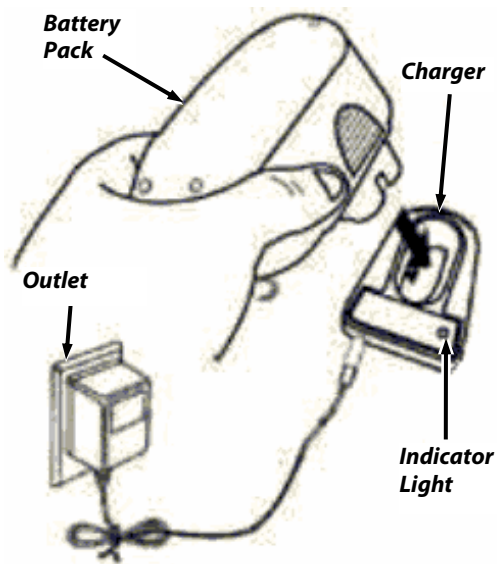
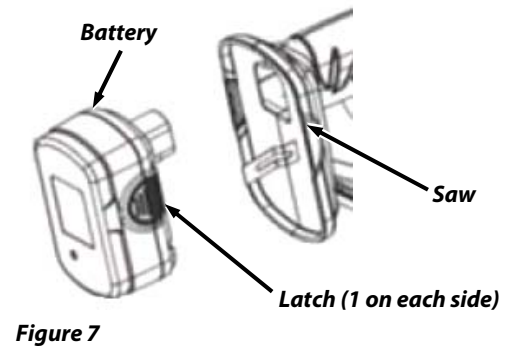

Figure 6

! CAUTION

When installing the Battery Pack, DO NOT push the Lock-Off Button or squeeze the Trigger ON/OFF Switch.

3. Install the Charged Battery Pack in your NEUTON Pole Saw by aligning the connector on the Battery Pack with the receptacle at the rear of the Saw and insert the Battery Pack (**Figure 7**) until the Latches on each side of the Battery Pack snap into place; assuring a secure connection to the Saw. Again, the Battery Pack and Saw Housing have keyways so they will fit together only one way.
4. To remove the Battery Pack, simply press both Latches on sides of the Battery Pack to release the Battery Pack from the NEUTON Pole Saw Housing and pull the Battery Pack straight out.



Add Oil for Chain Lubrication

NOTICE

Failure to lubricate the chain will cause damage to the bar and chain

Your NEUTON Pole Saw is equipped with an Automatic Oil Pump for Bar and Chain oiling.

1. Remove the Oil Cap (**Figure 8**) and add the #32 Bar & Chain Oil provided.

NOTE: Use only a good quality bar and chain oil or, if not available, unused SAE 30 weight motor oil may be substituted. One minute of use will consume approximately 0.1 fl. oz. (3ml) of oil. Refill when the oil level drops to 1/4 of a tank.

Your Neuton Pole Saw is now ready to use.

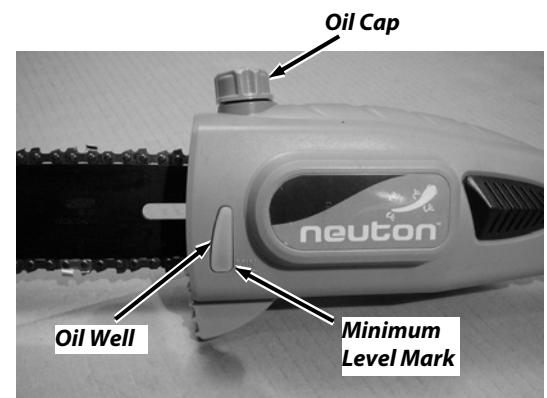

Figure 8

! WARNING

If any parts are damaged or missing do not operate this product until the parts are replaced. Failure to heed this warning could result in serious personal injury.

Chapter 3: Operating The NEUTON Pole Saw

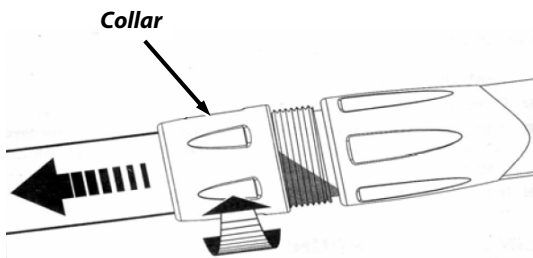

Figure 9

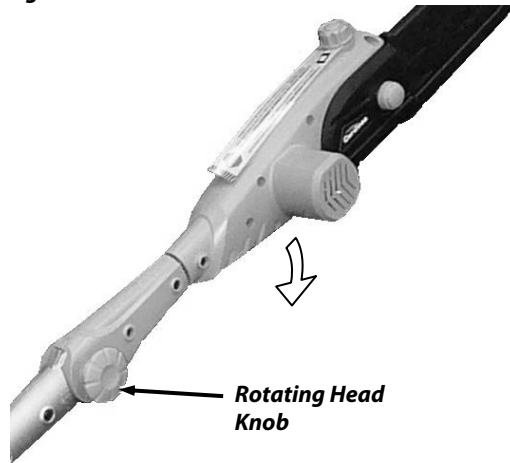

Figure 10

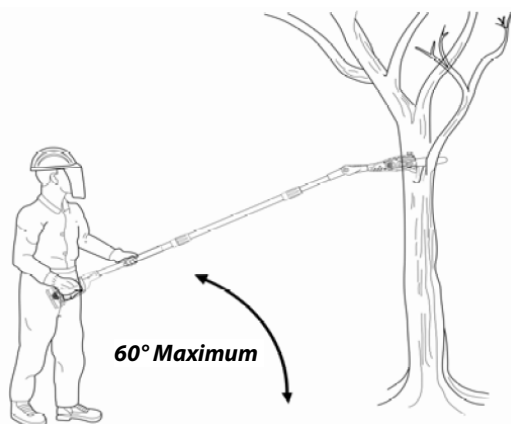

Figure 11

Proper Cutting Stance

- Weight should be balanced with both feet on solid ground.
- A good, firm grip on the pole and handle with both hands will help you maintain control. Grip the rear handle with your right hand whether you are right or left handed. Wrap the fingers of your left hand over and around the pole shaft. A firm grip together with positioning handle against your body will help you maintain control of the saw. Don't let go.
- Your body should always be to the left of the chain line.
- The most typical cutting application is to position the unit at an angle of 60° or less depending on the specific situation (Figure 11). As the angle of the pole saw shaft to ground increases, the difficulty of making the first cut (from the underside of limb) increases.

Adjusting Telescoping Pole

⚠ WARNING

Stop the motor, wait for the blade to stop, wait five minutes for the saw to cool, remove the battery and wear gloves to protect your hands from the chain teeth before performing any adjustment on the saw.

1. Rotate the collar counterclockwise to loosen (Figure 9).
2. Push poles towards each other to shorten the pole or pull away from each other to lengthen the pole.
3. When the desired length is achieved, rotate the collar clockwise to secure.
4. Be certain the collars are fully tightened before operating equipment. Check them periodically for tightness during use to avoid serious injury.

Note: Adjust hand placement on the shaft of the pole saw to keep proper balance. Do not attempt to use the pole saw at a length which does not allow you to achieve proper footing and balance at all times.

Adjusting the Angle of the Pole Saw Head

1. Turn the Knob on Rotating Head counter clockwise to loosen Power Head (Figure 10).
2. Adjust to desired position.
3. Turn the Knob clockwise to tighten. Failure to secure properly may result in personal injury and or property damage.

⚠ WARNING

- Read instruction manual before using. Keep Manual for future use.
- Keep hands on handle and pole shaft and away from chain.
- Do not overreach.
- Chain coasts after turned off.
- Do not use under wet conditions.
- Do not allow familiarity with this type of product to make you careless. Remember that a careless fraction of a second is sufficient to inflict serious injury.
- Do not cut vines and/or small underbrush with the Pole Saw.
- Do not use the pole saw with any type of accessory or attachment. Such usage might be hazardous and would void the warranty.
- Before you start the unit, make sure the blade is not contacting any object.

⚠ WARNING

Wear a safety hard hat with a full face shield that meets the ANSI Standards ANSI Z89.1 or CE Standards while operating the pole saw.

To Turn the Saw On and Off

1. Push the Lock-Off Button in with your thumb and then squeeze the Trigger with your fingers (**Figure 12**). Once the tool is running, you can release the lock-off button.
2. To turn the Saw OFF, release the Trigger.

Basic Cutting Procedure

This unit is designed for trimming small branches and limbs up to 6 in. in diameter.

Push and Pull – This reaction force is always opposite to the direction the chain is moving where wood contact is made. Thus, the operator must be ready to control the PULL when cutting on the bottom edge of the bar, and PUSH when cutting along the top edge.

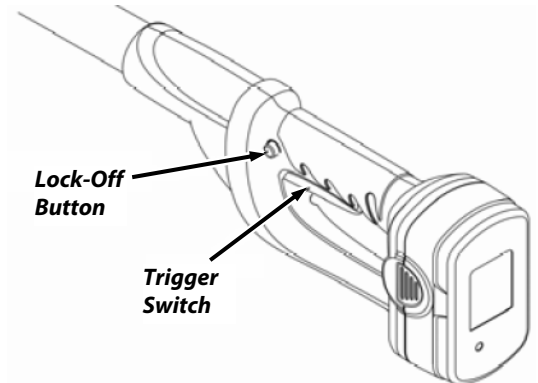

Figure 12

⚠ DANGER

- If the tree branch makes contact with any utility line, stay away and notify the utility company immediately.
- Do not cut trees near electrical wires or buildings.
- To protect yourself from electrocution, do not operate within 50ft. of overhead power lines (**Figure 13**).
- Keep bystanders at least 50ft. away (**Figure 14**).

Practice cutting a few small limbs using the following technique to get the "feel" of using the saw before you begin a major sawing operation.

1. Take the proper stance in front of the wood with the saw off.
2. Press in the Lock-off Button with your thumb and squeeze the Trigger and let the Chain accelerate to full speed before entering the cut.
3. Hold the Pole Saw firmly with both hands. Always keep one hand firmly on the Pole with your other hand on the Molded Handle so that the Handle is positioned firmly against your body for adding balance during cutting.
4. Keep the unit running the entire time you are cutting and maintain a steady speed.

NOTE: Allow the chain to cut for you; exert only light downward pressure. If you force the cut, damage to the bar, chain, or unit can result.

5. Do not put pressure on the Saw at the end of the cut.

Limbing

Limbing is removing branches from a fallen tree.

- Work slowly, keeping both hands on the pole saw with a firm grip. Always make sure your footing is secure and your weight is distributed evenly on both feet.
- Leave the larger support limbs under the tree to keep the tree off the ground while cutting.
- Limbs should be cut one at a time. Remove the cut limbs from the work area often to help keep the work area clean and safe.
- Branches under tension should be cut from the bottom up to avoid binding the pole saw.
- Keep the tree between you and the pole saw while limbing. Cut from the side of the tree opposite the branch you are cutting.

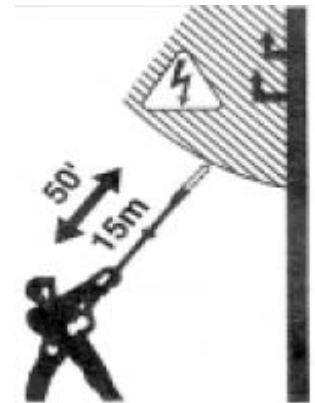

Figure 13

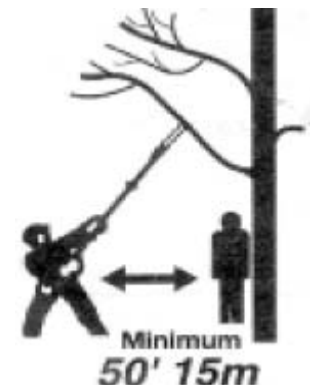

Figure 14

Pruning

Pruning is trimming limbs from a live tree.

WARNING

- Plan the cut carefully. Be aware of the direction in which the branch will fall. Branches may fall in unexpected directions. Do not stand directly under the branch being cut.
- If the tree limb starts to fall in the wrong direction, or if the saw gets caught or hung up during the fall, leave the saw and save yourself.
- Periodically glance at the top of the tree during the back-cut to assure the tree limb is going to fall in the desired direction.
- Always cut with both feet on solid ground to prevent being pulled or knocked off balance.
- Never climb into a tree to limb to prune. Do not stand on ladders, platforms, a log, or in any position which can cause you to lose your balance or control of the saw.
- Use extreme caution when cutting limbs under tension, because tense material may catch the saw and be whipped toward you, pull you off balance or spring back.

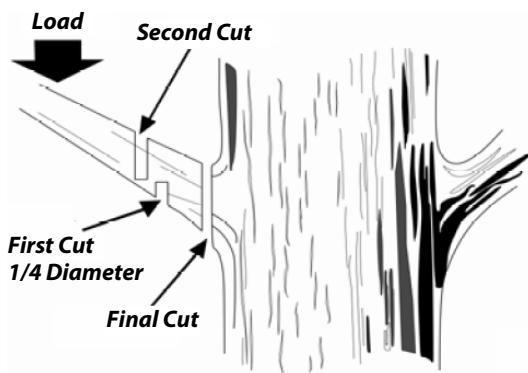

Figure 15



Figure 16

- Work slowly, keeping both hands on the pole saw with a firm grip and the handle positioned firmly against your body for added control and ease of handling. Always make sure your footing is secure and your weight is distributed evenly on both feet.
- Remove long branches in several stages.
- Cut lower branches first to allow the top branches more room to fall.
- When pruning trees it is important not to make the finishing cut next to the main limb or trunk until you have cut off the limb further out to reduce the weight. This prevents stripping the bark from the main member.

1. Make a shallow first cut (1/4 of limb diameter) on the underside of the limb close to the main limb or trunk. (Figure 15).
2. Make a second cut from the top side of the limb outboard from the first cut. Continue the cut through the limb until the limb separates from the tree. Be prepared to balance the weight of the tool when the limb falls.

NOTE: For second and final cuts (from top of limb or branch), hold front cutting guide against the limb being cut (Figure 16). This will help steady the limb and make it easier to cut. Allow the chain to cut for you; exert only light downward pressure. If you force the cut, damage to the bar, chain, or motor can result.

3. Now make your finishing cut smoothly and neatly close to the main member so the bark will grow back to seal the wound.
4. Release the trigger as soon as the cut is completed. Failure to follow proper cutting procedures will result in the bar and chain binding and becoming pinched or trapped in the limb.

If the Saw Becomes Pinched or Trapped

WARNING

Stop the motor, wait for the blade to stop, wait five minutes for the saw to cool, remove the battery and wear gloves to protect your hands from the chain teeth before performing any maintenance or inspection on the saw.

1. If the limb can be reached from the ground, lift the limb while holding the saw. This should release the "PINCH" and free the saw.
2. If the saw is still trapped, call a professional for assistance.

Minimize Kickback

WARNING

Kickback may occur when the moving chain contacts an object at the upper portion of the tip of the guide bar or when the wood closes in and pinches the pole saw in the cut. Contact at the upper portion of the tip of the guide bar can cause the chain to dig into the object and stop the chain for an instant. The result is a lightning fast, reverse reaction which kicks the guide bar up and back toward the operator. If the pole saw is pinched along the top of the guide bar, the guide bar can be driven rapidly back toward the operator. Either of these reactions can cause loss of saw control which can result in serious injury. Do not rely exclusively upon the safety devices built into the saw. As a pole saw user, you should take several steps to keep your cutting jobs free from accident or injury.

The following precautions should be followed to minimize kickback:

- Before you start the unit, make sure the pole saw is not contacting any object.
- Always grip the Pole and Handle firmly with both hands when unit is running. Place one hand on the Pole and your other hand on the Molded Handle with your thumbs and fingers encircling the Pole and Handle. A firm grip together with positioning The Handle against your body will help you maintain control of the Saw if kickback occurs.
- Make sure that the area in which you are cutting is free from obstructions.
- Do not let the Kickback danger Zone area of the Guide Bar contact a log, Branch, fence or any other obstruction that could be hit while you are operating the Saw (**Figure 17**).
- Always cut with the unit running at full speed. Fully squeeze the Throttle Trigger and maintain a steady cutting speed.
- Wear non-slip gloves for maximum grip and protection.
- Extend the pole only to the length required to reach the limb cut. Do not extend the handle above waist height.

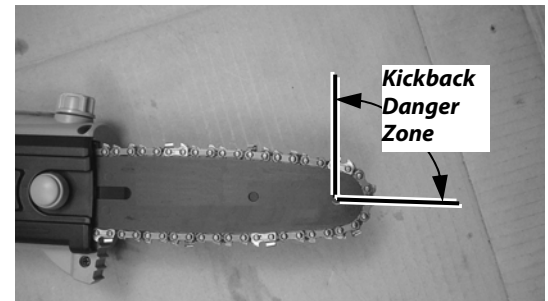

Figure 17

Chapter 4: Maintaining The NEUTON Pole Saw

Regular maintenance is the way to ensure the best performance and long life of your machine. Please refer to this section for maintenance procedures.

! WARNING

Stop the motor, wait for the blade to stop, wait five minutes for the saw to cool, remove the battery and wear gloves to protect your hands from the chain teeth before performing any maintenance or inspection on the saw.

Regular Maintenance Checklist

PROCEDURE	BEFORE EACH USE	AS NEEDED
Check Chain Teeth for sharpness and damage	▲	
Check General Equipment Condition	▲	
Clean Sawdust and debris from Saw	▲	
Check Chain Lubricating Oil Level	▲	
Check Chain Tension	▲	
Sharpen Teeth		when dull
Replace the Chain		*

*Broken Teeth or Teeth worn down too small from sharpening

Properly Adjusted Warm Chain



Flats

Chain Needs Tensioning



Figure 18

Chain Tension

NOTE: Chain must be re-tensioned whenever the flats on the drive links hang out of the bar groove (Figure 18).

! WARNING

Stop the motor, wait for the blade to stop, wait five minutes for the saw to cool, remove the battery and wear gloves to protect your hands from the chain teeth before performing any maintenance or inspection on the saw.

During normal saw operation, the temperature of the chain will increase. The drive links of a correctly tensioned warm chain will hang approximately .050 in. (1.25mm) out of the bar groove. Be aware that chain tensioned while warm, may be too tight upon cooling. Check the "cold tension" before next use. A cold chain will be correctly tensioned when there is no slack on the underside of the guide bar, the chain is snug, but it can be turned by hand without binding.

NOTE: A new chain tends to stretch. Check chain tension frequently and tension as required. A new chain tends to stretch, check chain tension frequently and tension as required.

Tools and Supplies Needed:

- Spanner Wrench
 - Gloves
1. Loosened the Sprocket Cover Bolt (Spanner Wrench) so it is only finger tight (Figure 19).
 2. Turn the Chain Tensioner Screw clockwise to tension the Chain as described above.
 3. Tighten the Sprocket Cover Bolt.

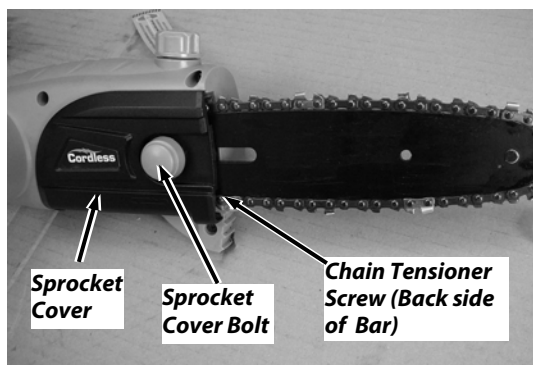

Figure 19

Chain Sharpening

! WARNING

- Stop the motor, wait for the blade to stop, wait five minutes for the saw to cool, remove the battery and wear gloves to protect your hands from the chain teeth before performing any maintenance or inspection on the saw.
- Improper chain sharpening increases the potential of kickback.
- Failure to replace or repair damaged chain can cause serious injury.

For smooth and fast cutting the chain needs to be sharpened when the wood chips are small and powdery, the chain must be forced through the wood during cutting, or the chain cuts to one side.

During sharpening of your chain remember:

- Improper filing angle of the side plate can increase the risk of severe kickback.
- Raker (depth gauge) clearance (see Figure 23).
 - Raker too low increases the potential for kickback.
 - Raker not low enough decreases cutting ability.
- If cutter teeth have hit hard objects such as nails and stones, or have been abraded by mud or sand on the wood, have service dealer sharpen chain.

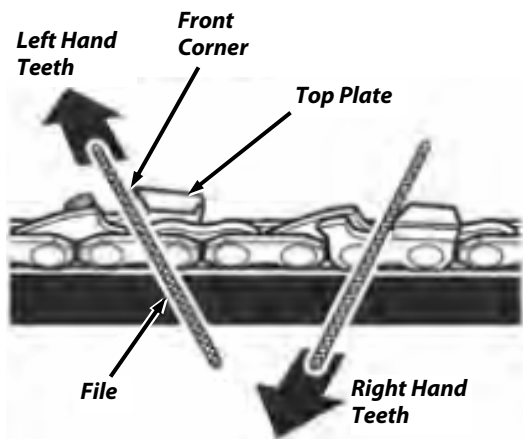

Figure 20

Sharpening the Chain Teeth

Tools and Supplies Needed:

- 5/32" diameter round file and holder
- Flat File
- Depth Gauge Jointer
- Wire Brush
- Gloves

Be careful to file all Teeth to the specified angles and to the same length, as fast cutting can be obtained only when all Teeth are uniform.

NOTE: Do all of your filing at the midpoint of the bar.

1. Properly tension the chain prior to sharpening. Refer to the "Chain Tension" Section earlier in this Chapter.
2. Keep the file level with the top plate of the tooth and do not let the file dip or rock, as you use light but firm pressure to stroke the file towards the front corner of the tooth (**Figure 20**).
3. Put a few firm strokes on every tooth and lift the file away from the Teeth on each return stroke.
4. File all left hand cutters in one direction. Then move to the other side and file the right hand cutters in the opposite direction.
5. Occasionally remove filings from the file with a wire brush.

Top Plate Filing Angle (Figure 21)

Correct 30 degrees - File holders are marked with guide marks to align file properly to produce top plate angle.

Less than 30 degrees - for Cross cutting.

More than 30 degrees - feathered edge dulls quickly.

Side Plate Angle (Figure 22)

Correct - 80 degrees produced automatically if correct diameter file (5/32" diameter round file) is used in file holder.

Correct Top Plate Filing Angle

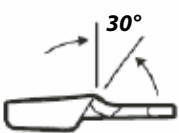

Incorrect Top Plate Filing Angle

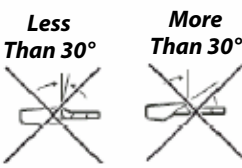
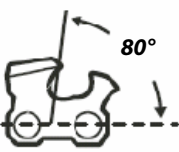

Figure 21

Correct Side Plate Filing Angle



Incorrect Side Plate Filing Angle

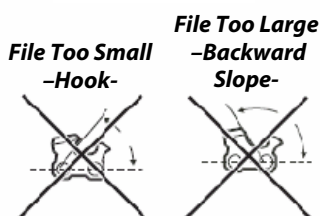

Figure 22

Hook - "Grabs" and dulls quickly. Increases potential of kickback. Results from using a file with a diameter too small, or file held too low.

Backward Slope - Needs too much feed pressure, causes excessive wear to bar and chain. Results from using a file with a diameter too large, or file held too high.

Raker (Depth Gauge) Clearance

Tools Needed:

- Flat File
- Depth Gauge Jointer

The Rakers (Depth Gauges) should be maintained at a clearance of .025 in. (0.6 mm). Use a depth gauge Jointer for checking the Raker clearances. Every time the Chain is filed, check the Raker clearance.

Use a Flat File and a Depth Gauge Jointer to lower all Rakers uniformly. Depth Gauge Jointers are available in .020 in. to .035 in. (0.5 mm to 0.9 mm). Use a .025 in. (0.6 mm) Depth Gauge Jointer for this Pole Saw.

Rakers must be adjusted with the flat file in the same direction the adjoining Tooth was filed with the round file. Use care not to contact Tooth face or adjoining drive links with flat file when adjusting Rakers.

1. Position the Depth Gauge Jointer onto the Chain so the Raker rests in the groove of the Depth Gauge Jointer (**Figure 23**).
2. File the Raker in a forward motion (lift file from Raker on return stroke) and stop filing just before the file hits the Jointer.
3. Move to the next Raker, file it to the correct depth and then continue until all of the Rakers are at the same depth.
4. After lowering each Raker, restore original shape by rounding the front.

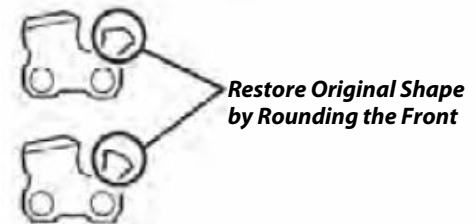
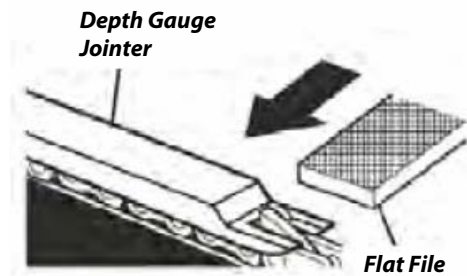
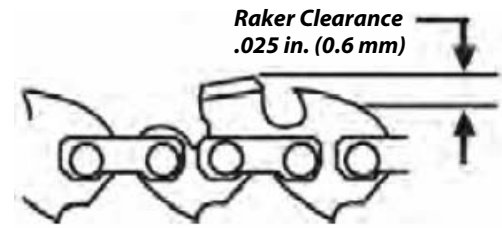

Figure 23

Replacing The Guide Bar And Chain

⚠ WARNING

- To avoid serious personal injury, read and understand all the safety instructions provided.
- Stop the motor, wait for the blade to stop, wait five minutes for the saw to cool, remove the battery and wear gloves to protect your hands from the chain teeth before performing any maintenance or inspection on the saw.
- Never start the motor before installing the guide bar, chain, sprocket cover and sprocket cover bolt. Without all these parts in place, the clutch can fly off or explode, exposing the user to possible serious injury.
- Never touch or adjust the chain while the motor is running. The saw chain is very sharp; always wear protective gloves when performing maintenance to the chain to avoid possible serious lacerations.

NOTE: When replacing the guide bar and chain, use only identical replacement parts. Inspect the drive sprocket for wear or damage when replacing the chain. If signs of wear or damage are present in the areas indicated, have the drive sprocket replaced by an authorized service dealer.

1. Remove the Battery from the Pole Saw.

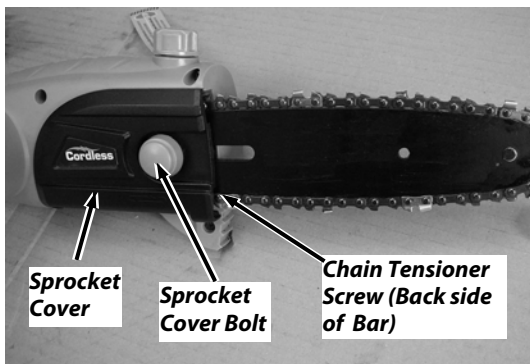

Figure 24

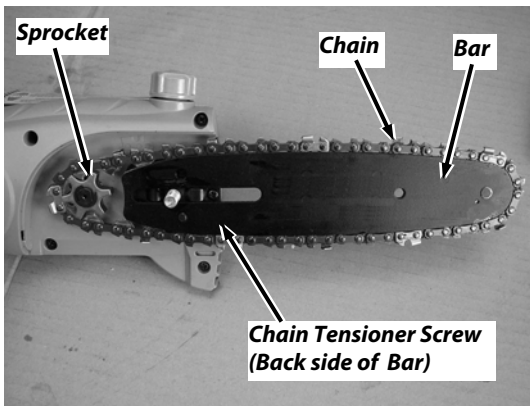

Figure 25

2. Remove the Sprocket Cover Bolt (**Figure 24**).
3. Remove the Sprocket Cover.
4. Remove the Bar and Chain from the mounting surface. You may need to loosen the Chain Tensioner Screw to make removal of the Bar and Chain easier (**Figure 25**).
5. Remove the Old Chain from the Bar.

Refer to the "Assembling" section in Chapter 2 to finish the installation and tensioning procedures.

Maintaining The Battery Pack

- Recharge the battery as soon as the cutting power of your cordless pole saw is no longer effective.
- When fully charged, the battery can be safely stored in temperatures down to -40 degrees F for a period of up to two weeks, before requiring charging. Fully charge battery pack every 30 days.
- If over a period of time the battery pack quickly runs down after a full 5-6 hour charging period, a replacement battery pack is needed.
- Avoid running the battery into full discharge (draining the battery completely).
- A good time to consider purchasing a replacement Battery Pack is when the Battery Pack takes longer than six (6) hours to charge
- Since the battery will not develop a memory, it does not have to be fully discharged before recharging.

NOTICE

- Charge the battery pack only with the charger provided.
- Make sure the Charger Power Supply is plugged into a normal household voltage, 120volts, 60Hz, AC only.
- You should operate the Battery Charger indoors in a dry place with temperatures between 23°F and 104°.
- Disconnect Charger Power Supply from the household voltage power when not in use to prevent damage to the Charger during a power surge.
- Periodically inspect the Cord on the Charger unit for damage. If damage occurs, do not use the Charger until you have replaced or repaired the Cord. Do not abuse the Cord. Never carry the Charger by the Cord. Always pull the plug – and not the Cord – when disconnecting the Power Supply from the electrical outlet (wall outlet) and from the Charger. When using an extension Cord with your Charger, use a heavy-duty extension Cord.
- A Battery Pack may last much longer if you charge it as soon as it starts to lose power and not let it completely discharge. Recharge the Battery Pack as soon as the cutting power of your NEUTON Pole Saw is no longer effective. This would be a good time to have a spare Battery Pack ready to go.
- Do not attempt to open the charger or the unit. There are no customer serviceable parts inside.
- DO NOT incinerate battery packs even if they are severely damaged or completely worn out They can explode in a fire causing injury.
- To prevent permanent damage to the battery, never store in a discharged condition.

A small leakage of liquid from the battery cells may occur under extreme usage, charging or temperature conditions. This does not indicate a failure. However, if the outer seal is broken and this leakage gets on your skin.

- a. Wash quickly with soap and water.
- b. Neutralize with a mild acid such as lemon juice or vinegar.
- c. If the battery liquid gets in your eyes, flush them with clean water for a minimum of 10 minutes and seek immediate medical attention.

To Charge

See “Charge the Battery Pack before your first use” in Chapter 2 to charge the Battery.

Battery Disposal

Remove the battery pack from the pole saw. Cover the terminals with heavy duty adhesive tape. Do not attempt to destroy or disassemble battery pack or remove any components.

This product contains nickel-cadmium batteries which must be recycled or disposed of properly. Local, state or federal laws may prohibit disposal of these batteries in ordinary trash. To preserve natural resources, please recycle or dispose of batteries properly. Consult your local waste authority for information regarding available recycling and/or disposal options.

General Maintenance

WARNING

Stop the motor, wait for the blade to stop, wait five minutes for the saw to cool, remove the battery and wear gloves to protect your hands from the chain teeth before performing any maintenance or inspection on the saw.

NOTICE

- Do not at any time let brake fluids, gasoline, petroleum based products, penetrating oils, etc., come in contact with plastic parts. They contain chemicals that can damage, weaken or destroy plastic.
- Fertilizers and other garden chemicals contain agents which greatly accelerate the corrosion of metals. Do not store the tool on or adjacent to fertilizers or chemicals.

If you drop the pole saw, carefully inspect it for damage. If the blade is bent, housing cracked, or handles broken or if you see any other condition that may affect the saws operation, contact your local Authorized Service Center for repairs before putting it back into use.

Use only mild soap and a damp cloth to clean the tool. Never let any liquid get inside the tool; never immerse any part of the tool into a liquid.

To assure product SAFETY and RELIABILITY, repairs, maintenance and adjustment should be performed by an authorized service center or other qualified service organization, always using identical replacement parts.

Ensure that the plastic blade cover is in place when Saw is not being used.

Lubrication System

WARNING

- Stop the motor, wait for the blade to stop, wait five minutes for the saw to cool, remove the battery and wear gloves to protect your hands from the chain teeth before performing any maintenance or inspection on the saw.
- Use only new chain oil specifically formulated for pole saws. Never use waste oil, low quality oil, or insufficient oil. This could damage the pump, the bar and the chain which may result in serious personal injury.

Before using the Pole Saw, Fill oil tank with new quality bar and oil formulated and recommended for pole saws.

Check oil level before each work session, refill if less than 1/4. full.

If the lubrication system does not work properly, check if the oil filter and all oil ways are clean and free from obstructions.

NOTE: It is normal for oil to seep from the saw when not in use. To prevent seepage, empty the oil tank after each use.

Guide Bar Maintenance

When the guide bar shows signs of wear, reverse it on the saw to distribute the wear for maximum bar life. The bar should be cleaned every day of use and checked for wear and damage.

Feathering or burring of the bar rails is a normal process of bar wear. Such faults should be smoothed with a flat file as soon as they occur.

A bar with any of the following faults should be replaced:

- Wear inside the bar rails which permits the chain to lay over sideways.
- Bent guide bar
- Cracked or broken rails
- Spread rails

In addition, guide bars with a sprocket at their tip must be lubricated weekly with a grease syringe to extend the guide bar life. Using a grease syringe (available at your local chain saw dealer). lubricate weekly in the lubricating hole.

Turn the guide bar and check that the lubrication holes and chain groove are free from impurities.

Chapter 5: Troubleshooting

Most problems are easy to fix. Consult the Troubleshooting Table below for common problems and their solutions. If you continue to experience problems, contact us at www.neutonpower.com or call 1-866-NEUTON1 (638-8661) for support.

WARNING

Stop the motor, wait for the blade to stop, wait five minutes for the saw to cool, remove the battery and wear gloves to protect your hands from the chain teeth before performing any maintenance or inspection on the saw.

Troubleshooting Table

SYMPTOM	POSSIBLE CAUSE/SOLUTION
<i>Unit does not run</i>	<ul style="list-style-type: none"> ⇒ Battery in not charged. Charge Battery. ⇒ Battery in not inserted into the Saw correctly. Insert Battery. ⇒ Lock Off not fully operated. Check that Lock Off is fully depressed prior to engaging trigger switch.
<i>Bar and chain running hot and smoking</i>	<ul style="list-style-type: none"> ⇒ Check tension for over-tight condition. Adjust chain tension. ⇒ Chain oil tank empty. Fill tank with chain oil. ⇒ The lubrication holes are plugged. Clean out the lubrication holes.
<i>Motor runs but chain is not rotating</i>	<ul style="list-style-type: none"> ⇒ Chain tension too tight. Adjust chain tension. ⇒ Check guide bar and chain for damage. Replace damaged bar and chain with identical replacement parts or contact an authorized service center for repair.
<i>The Motor runs, but the Chain speed Is low.</i>	<ul style="list-style-type: none"> ⇒ The Battery Pack was probably not at full charge prior to cutting. Charge the Battery Pack, if necessary. ⇒ The Chain is loose. Re-tension.
<i>The Battery Pack will not charge</i>	<ul style="list-style-type: none"> ⇒ You did not insert the Battery Pack all the way into the Charger. Insert the Battery Pack until the Red LED Light illuminates. ⇒ The Charger Power Supply is not in a working outlet. Check the outlet with a lamp or other appliance. ⇒ Check to see if the outlet that you are using for the Charger Power Supply is controlled from a wall switch. ⇒ The surrounding air temperature is too hot or too cold. Move Charger and Battery Pack to a location where the surrounding air temperature is between 40°F (5°C) and +95°F (+35°C).
<i>The Battery loses its charge quickly.</i>	<ul style="list-style-type: none"> ⇒ The Battery Pack was probably not at full charge prior to cutting. Charge the Battery Pack, if necessary. <p>NOTE: You will need to charge a new Battery Pack at least five (5) times to achieve maximum cutting time.</p> <ul style="list-style-type: none"> ⇒ The Battery Pack may be getting old. After some time, you will need to replace the Battery Pack.

Chapter 6: Parts Lists, Schematic Diagrams And Warranty

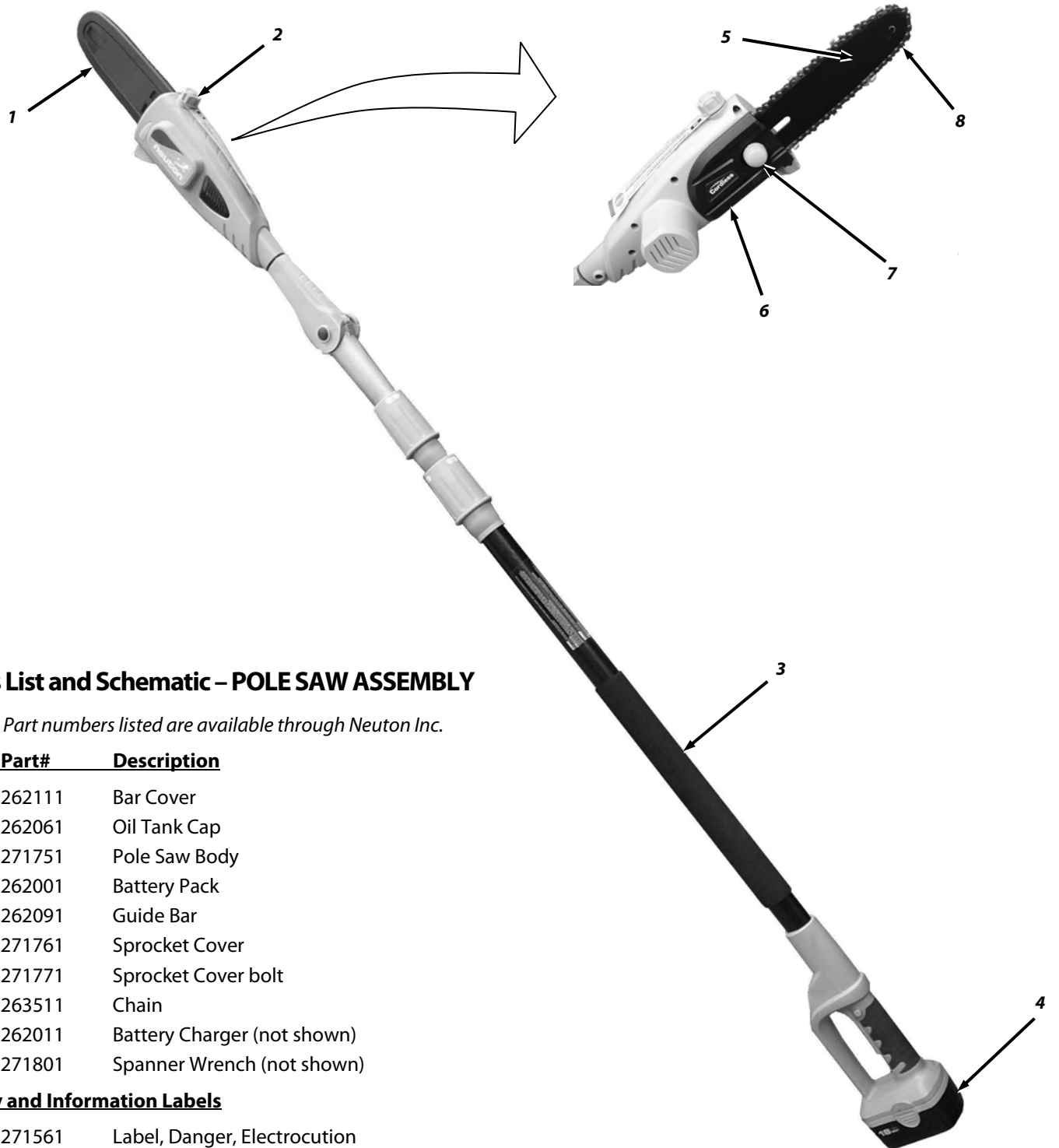

Parts List and Schematic – POLE SAW ASSEMBLY

NOTE: Part numbers listed are available through Neuton Inc.

Ref#	Part#	Description
01	262111	Bar Cover
02	262061	Oil Tank Cap
03	271751	Pole Saw Body
04	262001	Battery Pack
05	262091	Guide Bar
06	271761	Sprocket Cover
07	271771	Sprocket Cover bolt
08	263511	Chain
09	262011	Battery Charger (not shown)
10	271801	Spanner Wrench (not shown)

Safety and Information Labels

271561	Label, Danger, Electrocutation
271571	Tag, Check Chain Oil
271581	Label, Warning, Reduce Risk of Shock
271591	Label, Note, Indicator Light
271601	Label, Note, Charger Input

Notes:

1-Year Limited Warranty

Terms and Conditions

The NEUTON® Pole Saw is warranted for one (1) year against defects in materials or workmanship when put to personal residential household use.

For the purposes of the warranty, “personal residential household use” refers to non-commercial residential use and further excludes misuse, accidents, or damage due to inadequate maintenance.

Neuton Inc. certifies that the NEUTON® Pole Saw is fit for ordinary purposes for which a product of this type is used. Neuton Inc. however, limits the implied warranties of merchantability and fitness in duration to a period of one (1) year in personal residential household use.

The 1-Year Limited Warranty on the NEUTON® Pole Saw starts on the date the machine shipped from our factory. The 1-Year Limited Warranty is applicable only to the original owner.

The owner is responsible for the performance of all the required maintenance as defined by the manufacturer's owner manual.

The owner is responsible for the replacement of normally wearing parts including the Chain, Bar, and the Battery.

During the warranty period, the owner is responsible for all shipping and transportation charges, if required.

SOME STATES DO NOT ALLOW LIMITATIONS ON THE LENGTH OF IMPLIED WARRANTIES, SO THE ABOVE LIMITATIONS MAY NOT APPLY TO YOU.

Neuton Inc. shall not be liable under any circumstances for any **incidental or consequential damages or expenses** of any kind, including, but not limited to, cost of equipment rentals, or cost of hiring services to perform tasks normally performed by the NEUTON® Pole Saw.

SOME STATES DO NOT ALLOW THE EXCLUSION OR LIMITATION OF INCIDENTAL OR CONSEQUENTIAL DAMAGES, SO THE ABOVE LIMITATIONS MAY NOT APPLY TO YOU.

THIS WARRANTY GIVES YOU SPECIFIC LEGAL RIGHTS, AND YOU ALSO HAVE OTHER RIGHTS, WHICH VARY FROM STATE TO STATE.

Daily Checklist for the NEUTON Pole Saw

To help maintain your NEUTON Pole Saw for optimum performance, we recommend you follow this checklist each time you use your Saw.

WARNING

Stop the motor, wait for the blade to stop, wait five minutes for the saw to cool, remove the battery and wear gloves to protect your hands from the chain teeth before performing any maintenance or inspection on the saw.

- [] Check Teeth for sharpness and Raker depth.
- [] Check Chain for proper tension.
- [] Check oil level.
- [] Check the general condition of the Saw, e.g.; cracks, loose hardware, etc.
- [] Check Battery for charge.

End of Season and Storage

WARNING

Stop the motor, wait for the blade to stop, wait five minutes for the saw to cool, remove the battery and wear gloves to protect your hands from the chain teeth before performing any maintenance or inspection on the saw.

- [] Ensure that the plastic Blade Cover is in place when storing.
- [] Do not store the Saw near chemicals, such as fertilizers, organic or other solvents. Do not expose brake fluids, gasoline, petroleum-based products, penetrating oils, etc., to the plastic parts of the Saw. These products are often highly corrosive and may cause permanent damage, weaken, or destroy the plastic to your Saw.
- [] Clean the Saw with mild soap and a damp cloth. Never let any liquid get inside the tool; never immerse any part of the tool into a liquid.
- [] When storing the unit for a long period of time (3 months or longer) be sure the Chain is lightly lubricated; this will prevent rust on the Chain and Bar Sprocket. Drain the oil if you wish to prevent leaking. Remember to add oil the next time you use the Saw.
- [] When not in use, your NEUTON Pole Saw should be stored indoors in a dry and high or locked-up place, out of reach of children.
- [] For superior Battery Pack performance, always store the Battery Pack in a DRY environment with temperatures between 40°F (5°C) and +95°F (+35°C). Make sure the storage temperatures will never be outside these limits. The lower the storage temperature is within the specified range, the better. The Battery Pack will discharge more slowly at low temperatures. Charge the Battery Pack for five (5) to six (6) hours prior to storage and then every one (1) to two (2) months; and then again prior to the first seasons use. To prevent permanent damage to the Battery Pack, never store it in a discharged condition. Always store the Saw with a full Battery Pack charge. Be sure to remove the Battery Pack from the Charger after charging. Also, do not store the Battery Pack near children or pets or close to a source of heat, sparks, open flame or on the floor as it may be damp or subject to accidental flooding. In addition, never expose the Battery Pack to abnormal shaking or shocks. Regularly observe the external appearance of the Battery Pack. Never use a Battery Pack that shows cracks, changes shape, leaks, or is obviously damaged. You can safely keep the Battery Pack in the Saw when storing for the long term.

Neuton Inc.

75 MEIGS ROAD, P.O. BOX 25, VERGENNES, VERMONT 05491
