



OPERATOR'S MANUAL

GENERAC® 9.5 CHIPPER W/SHREDDER



Serial No. _____

Order No. _____

Original Language

Generac Power Systems
Toll-free phone: 1-888-545-6576

! WARNING

Read and understand this manual and all instructions before operating the 9.5 CHIPPER W/SHREDDER.

Table of Contents

Chapter 1: General Safety Rules..... 4
Chapter 2: Setting Up The 9.5 Chipper w/Shredder 8
Chapter 3: Operating the 9.5 Chipper w/Shredder 14
Chapter 4: Maintaining The 9.5 Chipper w/Shredder 17
Chapter 5: Troubleshooting 22
Chapter 6: Parts Lists and Schematic Diagrams..... 24

Conventions used in this manual

DANGER

This indicates a hazardous situation, which, if not followed, will result in death or serious injury.

WARNING

This indicates a hazardous situation, which, if not avoided, could result in death or serious injury.

CAUTION

This indicates a hazardous situation, which, if not avoided, could result in minor or moderate injury.

NOTICE

This information is important in the proper use of your machine. Failure to follow this instruction could result in damage to your machine or property.

Serial Number and Order Number

A Serial Number is used to identify your machine and is located on the Serial Number Label on your machine. An Order Number is used to check and maintain your order history and is located on the upper left portion of your packing slip. For your convenience and ready reference, enter the Serial Number and Order Number in the space provided on the front cover of this manual.

Additional Information and Potential Changes

Generac Power Systems reserves the right to discontinue, change, and improve its products at any time without notice or obligation to the purchaser. The descriptions and specifications contained in this manual were in effect at printing. Equipment described within this manual may be optional. Some illustrations may not be applicable to your machine.

Chapter 1: General Safety Rules

WARNING

Read this Safety & Operating Instructions Manual before you use the 9.5 Chipper w/Shredder. Become familiar with the operation and service recommendations to ensure the best performance from your machine. If you have any questions or need assistance, please contact us at 1-888-545-6576 and one of our Technical Support Representatives will be happy to help you.

Labels

Your 9.5 Chipper w/Shredder carries prominent labels as reminders for its proper and safe use. Shown below are copies of all the Safety and Information labels that appear on the equipment. Take a moment to study them and make a note of their location on your Chipper w/Shredder as you set up and before you operate the unit. Replace damaged or missing Safety and Information labels immediately.

**WARNING: Check Oil
Before Starting Engine**

#13758



#18887



#36529



#36530

Protecting Yourself and Those Around You

WARNING

This is a high-powered machine, with moving parts operating with high energy. You must operate the machine safely. Unsafe operation can create a number of hazards for you, as well as anyone else in the nearby area. This machine can crush, grind, cut, and sever parts of your body if they enter the inlet or discharge area of your Chipper w/Shredder. Always take the following precautions when using this machine:

- Keep in mind that the operator or user is responsible for accidents or hazards occurring to other people, their property, and themselves.
 - Always wear protective goggles or safety glasses with side shields while using the Chipper w/Shredder to protect your eyes from possible thrown debris.
 - Avoid wearing loose clothing or jewelry, which can catch on moving parts or the material fed into the Chipper w/Shredder.
 - We recommend wearing gloves while using the Chipper w/Shredder. Be sure your gloves fit properly and do not have loose cuffs or drawstrings.
 - Wear shoes with non-slip treads when using your Chipper w/Shredder. If you have safety shoes, we recommend wearing them. Do not use the machine while barefoot or wearing open sandals.
 - Wear long pants while operating the Chipper w/Shredder.
 - Use ear protectors or earplugs rated for at least 20 dba to protect your hearing.
 - Keep bystanders at least 100 feet away from your work area. Stop the engine when another person or pet approaches.
-

Safety for Children and Pets

WARNING

Tragic accidents can occur if the operator is not alert to the presence of children and pets. Children are often attracted to the machine and the chipping/shredding activity. *Never* assume that children will remain where you last saw them. Always follow these precautions:

- Keep children and pets at least 100 feet from the working area and ensure they are under the watchful care of a responsible adult.
 - Be alert and turn the machine off if children or pets enter the work area.
 - Never allow children to operate the Chipper w/Shredder.
-

Safety with Gasoline - Powered Machines

WARNING

Gasoline is a highly flammable liquid. Gasoline also gives off flammable vapor that can be easily ignited and cause a fire or explosion. Never overlook the hazards of gasoline. Always follow these precautions:

- Never run the Engine in an enclosed area or without proper ventilation as the exhaust from the Engine contains carbon monoxide, which is an odorless, tasteless, and deadly poisonous gas.
 - Store all fuel and oil in containers specifically designed and approved for this purpose and keep away from heat and open flame, and out of the reach of children.
 - Replace rubber Fuel Lines and Grommets when worn or damaged and after 5 years of use.
 - Fill the Gasoline Tank outdoors with the Engine off and allow the Engine to cool completely. Don't handle gasoline if you or anyone nearby is smoking, or if you're near anything that could cause it to ignite or explode. Reinstall the Fuel Tank Cap and Fuel Container Cap securely.
 - If you spill gasoline, do not attempt to start the Engine. Move the machine away from the area of the spill and avoid creating any source of ignition until the gas vapors have dissipated. Wipe up any spilled fuel to prevent a fire hazard and properly dispose of the waste.
-

Safety with Gasoline - Powered Machines (Continued)

WARNING

- Allow the Engine to cool completely before storing in any enclosure. Never store a machine that has gas in the tank, or a Fuel Container, near an open flame or spark such as a water heater, space heater, clothes dryer or furnace.
 - Never make adjustments or repairs with the Engine running. Shut down the Engine, disconnect the Spark Plug wire, keeping it away from the Spark Plug to prevent accidental starting, wait 5 minutes before making adjustments or repairs.
 - Never tamper with the Engine's Governor setting. The Governor controls the maximum safe operation speed and protects the Engine. Over-speeding the Engine is dangerous and will cause damage to the Engine and to the other moving parts of the machine. If required, see your authorized dealer for Engine governor adjustments.
 - Keep combustible substances away from the Engine when it is hot.
 - Never cover the machine while the Muffler is still hot.
 - Do not operate the Engine with the Air Cleaner or the Carburetor Air Intake Cover removed. Removal of such parts could create a fire hazard. Do not use flammable solutions to clean the Air Filter.
 - The Muffler and Engine become very hot and can cause a severe burn; do not touch.
-

General Safety

WARNING

Operating this Chipper w/Shredder safely is necessary to prevent or minimize the risk of death or serious injury. Unsafe operation can create a number of hazards for you. Always take the following precautions when operating this machine:

- Your Chipper w/Shredder is a powerful tool, not a plaything. Exercise extreme caution at all times. The machine is designed to chip wood and shred most organic materials. Do not use it for any other purpose.
 - Thoroughly inspect the area in which you will be working and remove all foreign objects. Look for rope, wire, etc., and remove these objects before chipping/shredding. Inserting these objects into the Chipper w/Shredder Hopper could damage the machine and/or cause injury.
 - Know how to stop the Chipper w/Shredder quickly; see "Stopping the Engine" in Chapter 3.
 - Never operate your unit on a slippery, wet, muddy, or icy surface. Exercise caution to avoid slipping or falling.
 - See manufacturer's instructions for proper operation and installation of accessories. Only use accessories approved by Generac Power Systems.
 - Never use the machine without ensuring that all guards and shields are in place.
 - Never, under any conditions, remove, bend, cut, fit, weld, or otherwise alter standard parts on the Chipper w/Shredder. This includes all shields and guards. Modifications to your machine could cause personal injuries and property damage and will void your warranty.
 - Never use the machine with the Chipper Chute, Shredder Hopper, Blowback Guards, or Discharge Guard removed.
 - Never place any part of your body in the Chipper Chute, Shredder Hopper, discharge opening, or near any moving part while the machine is running. Keep the area of discharge clear of anything that will obstruct a clear discharge. Wind can also change discharge direction, so be aware. If it becomes necessary to push material into the Chipper Chute or Shredder Hopper, use a small diameter stick, NOT YOUR HANDS.
 - Keep your face and body back from the Chipper Chute and Shredder Hopper to avoid accidental bounce back of any material.
 - Do not allow an accumulation of processed material to build up in the discharge area as this will prevent proper discharge and can result in kickback.
 - Allow only one person to operate the Chipper w/Shredder at any time.
 - Always operate the machine from the Operator Zone (see **Figure 14** on page 14). Never pass or stand on the discharge side of the machine when the Engine is running or the Flywheel is turning.
 - If the machine should start making an unusual noise or vibration, shut down the Engine, disconnect the Spark Plug Wire, keeping it away from the Spark Plug to prevent accidental starting, wait 5 minutes, then inspect for damage. Vibration is generally a warning of trouble. Check for damaged parts and clean, repair, and/or replace as necessary.
 - Never tamper with safety devices. Check their proper operation regularly.
-

General Safety (continued)

! WARNING

- Never try to pick up, move, or transport the machine while the Engine is running or the Flywheel is turning.
 - Before performing any maintenance or inspection procedure on the Chipper w/Shredder, shut the Engine OFF, wait 5 minutes for machine to cool, remove the Spark Plug Wire keeping it away from the Spark Plug.
 - Never allow people who do not understand and/or have not read this Safety and Operating Instructions Manual to use the Chipper w/Shredder. Allow only responsible individuals who are familiar with these rules of safe operation to use your machine.
 - Never overload or attempt to Chip or Shred material beyond the manufacturer's recommendation. Personal injury or damage to the machine could result.
 - While using the Chipper w/Shredder, don't hurry or take things for granted. When in doubt about the equipment or your surroundings, stop the machine and take the time to look things over.
 - Never operate the machine when under the influence of alcohol, drugs, or medication.
 - Use the machine only in daylight.
 - Stay alert for hidden hazards or traffic.
 - Keep all nuts and bolts tight and keep the equipment in good operating condition.
-

California Proposition 65

! WARNING

California Proposition 65:

- Engine exhaust and some of its constituents are known to the State of California to cause cancer, birth defects, and other reproductive harm.
 - This product contains or emits chemicals known to the State of California to cause cancer, birth defects, and other reproductive harm.
-

A Note to All Users

Under California law, and the laws of some other states, you are not permitted to operate an internal combustion engine using hydrocarbon fuels without an Engine Spark Arrester. This also applies to operation on US Forest Lands. All Generac Chippers w/Shredder shipped to California, New Mexico, and Washington State are provided with Spark Arresters. Failure of the owner or operator to maintain this equipment in compliance with state regulations is a misdemeanor under California law and may be in violation of other state and/or federal regulations. Contact your State Park Association or the appropriate state organization for specific information in your area.

No list of warnings and cautions can be all-inclusive. If situations occur that are not covered by this manual, the operator must apply common sense and operate this 9.5 Chipper w/Shredder in a safe manner. Contact us at 1-888-545-6576 for assistance.

Chapter 2: Setting Up The 9.5 Chipper w/Shredder

It may be helpful to familiarize yourself with the controls and features of your 9.5 Chipper w/Shredder as shown in **Figure 1** before beginning these procedures. If you have any questions at all, please feel free to contact us at 1-888-545-6576.

9.5 Chipper w/Shredder Controls and Features

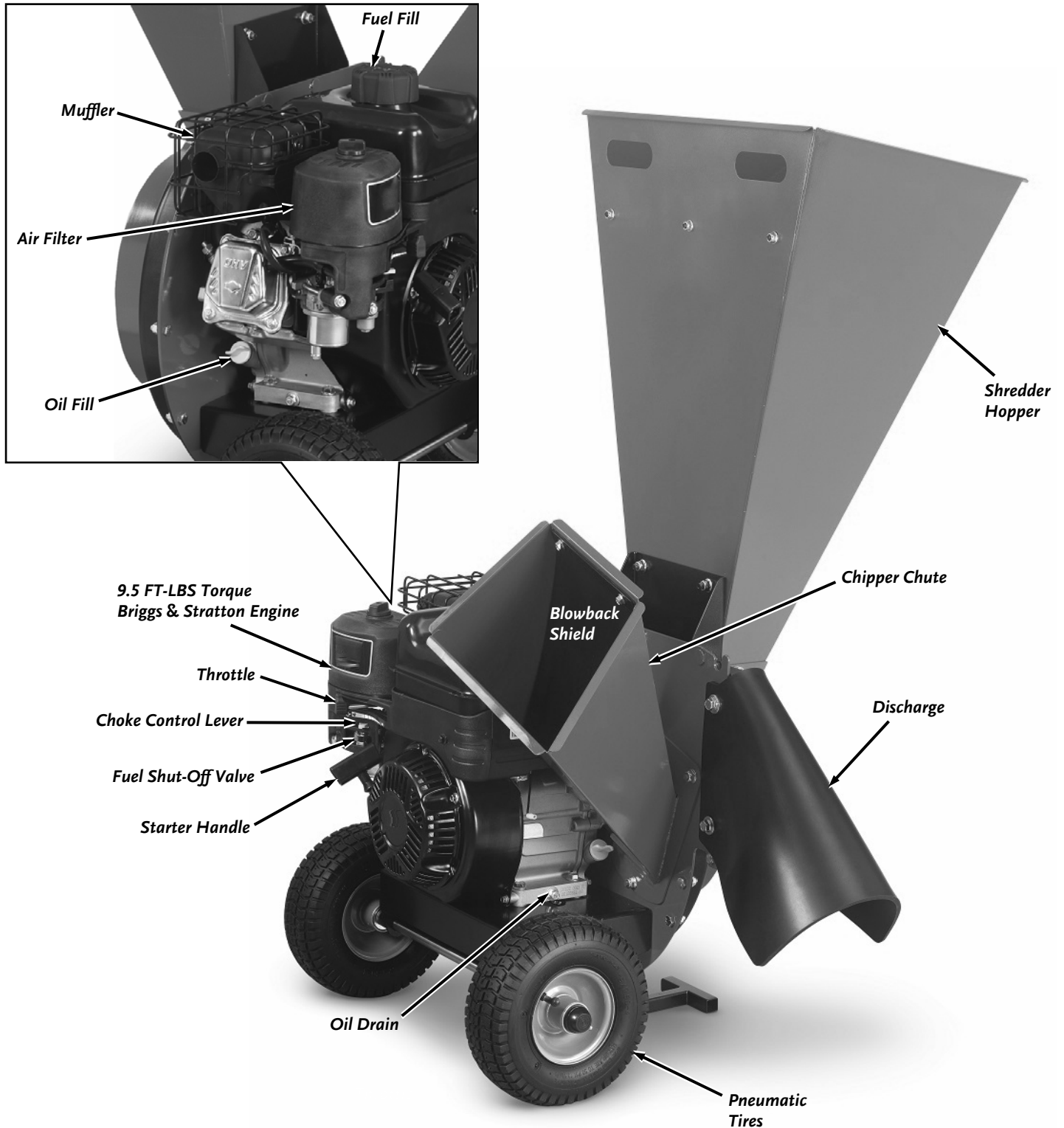

Figure 1

Specifications

Engine	Briggs & Stratton
Ft-Lbs Torque	9.50
Oil Capacity	20 oz.
Fuel Tank Capacity	0.8 Gallons
Starting	Manual
Chipping Capacity	3" Diameter Max Branches
Shredding Capacity	1/2" Diameter Max Woody Material
Chipper Knife	4-1/8"x 1-1/4" x 9/32" Thick
Shredding Hammers	8 Hardened Steel, 4 Flat and 4 J
Drive	Direct Mount Flywheel/Hammermill
Wheels	9/350 x 4, 4 Ply, Pneumatic
Unit Weight	126 pounds
Unit Dimensions	31-7/8" x 26-7/8" x 44-7/8" H

Assembly

Note: The 9.5 Chipper w/Shredder ships in 2 boxes.

Parts Supplied in Box 1 of 2 (Figure 2 and List below):

- 9.5 Chipper w/Shredder Power Unit
- Product Pack:
 - Safety and Operating Instructions Manual
 - Engine Manual
 - Hardware Bag

Hardware Bag Contents (Figure 3 and List below):

Item	Part#	Description	Qty
1	36503	Screw, Button HD Socket, 1/4-20 x 5/8"	4
2	33331	Nut, Nylon Lock, Flange, 1/4-20	7
3	33332	Nut, Nylon Lock, Flange, 5/16-18	12
4	35023	Bolt, Hex Flange, 5/16-18 x .75"	4
5	33804	Washer, .344" x .88" x .12"	4
6	11238	Washer, Flat, 1/4" USS	2

Parts Supplied in Box 2 of 2 (Figure 4 and list below):

- Shredder Hopper
- Chipper Chute
- Collection Bag
- Shredder Guard & Bracket Assembly
- Chipper Guard & Bracket Assembly
- Discharge Deflector

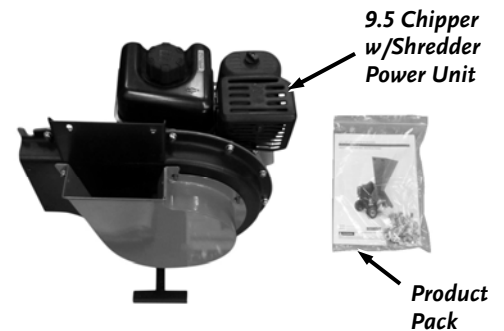

Figure 2

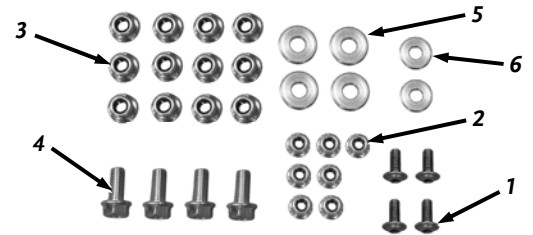

Figure 3

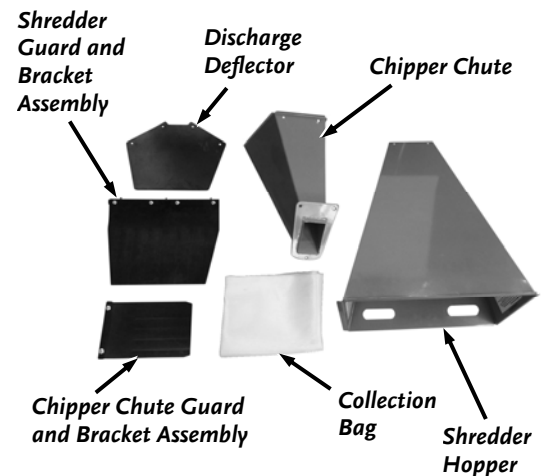

Figure 4

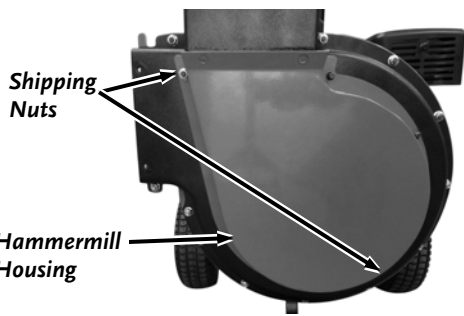

Figure 5

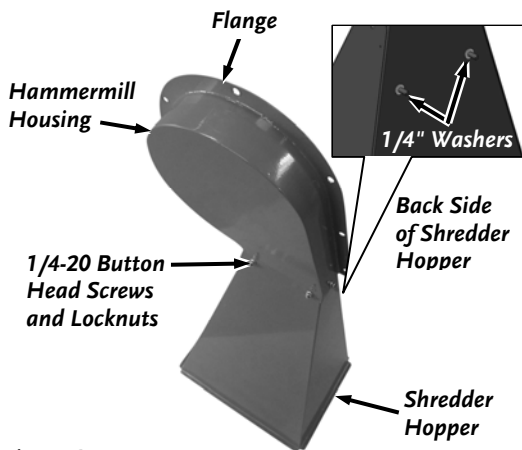

Figure 6

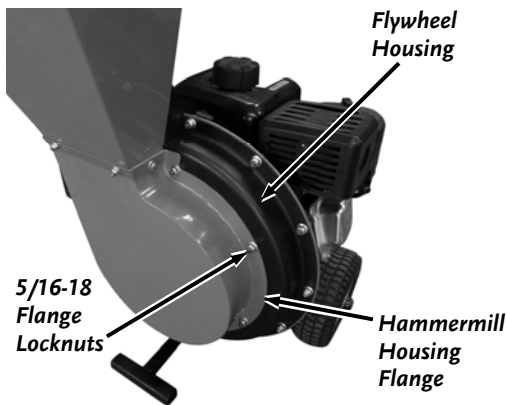

Figure 7

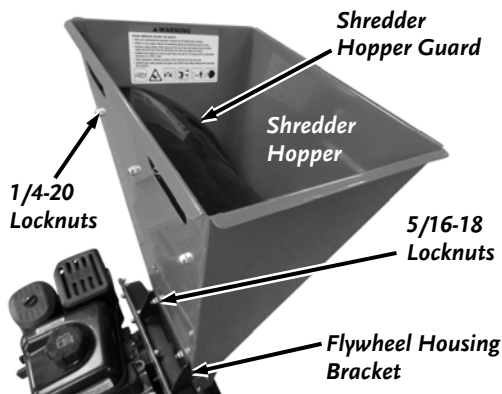

Figure 8

Attaching the Shredder Hopper and Hammermill Housing

Tools needed:

- 1/2" Wrench
- 5/32" Allen Wrench
- 7/16" Wrench
- 3/8" Wrench

1. Remove the two shipping nuts that are temporarily securing the Hammermill Housing to the Power Unit using a 1/2" Wrench (**Figure 5**). Discard the nuts.
2. Place a 1/4" Washer onto each of the two studs at the back of the Shredder Hopper. Make sure the Washers stay on the studs when performing the following steps.
3. Position the larger end of the Shredder Hopper on a flat surface and set the Hammermill Housing over the Shredder Hopper (**Figure 6**). Secure with four 1/4-20 Button Head Screws on the inside and 1/4-20 Locknuts on the outside using a 5/32" Allen Wrench for the Screws and 7/16" Wrench for the Locknuts.

Note: Make sure the Locknuts installed in step 3 are on the outside and the Button Head Screws on the inside.

Adjust the Shredder Hopper and Hammermill Housing as you tighten the hardware to make sure the back side of the Hopper is flush to the flange of the Housing.

4. Position the Hammermill Housing/Shredder Hopper Assembly onto the Flywheel Housing studs (**Figure 7**) and the studs of the Shredder Hopper into the Flywheel Housing Bracket (**Figure 8**).

Note: Ensure that the 1/4" Washers installed in step 2 are between the Shredder Hopper and Flywheel Housing Bracket.

5. Check the fit between the Hammermill Housing Flange to the Flywheel Housing (**Figure 7**). If there are any noticeable gaps, continue to step 6. If there are no noticeable gaps, go to step 7.
6. Remove the Hammermill Housing/Shredder Hopper Assembly, loosen the hardware installed in step 3 and adjust the Hammermill Housing and Shredder Hopper to align better with the Flywheel Housing. Retighten the hardware and return to step 4.
7. Secure the Flange of the Hammermill Housing with seven 5/16-18 Flange Locknuts (**Figure 7**) and the Shredder Hopper studs (**Figure 8**) with two Locknuts using a 1/2" Wrench.
8. Install the Shredder Hopper Guard Assembly to the Shredder Hopper with three 1/4-20 Flange Locknuts using a 7/16" Wrench.

Attaching the Chipper Chute:

1. Attach the Chipper Chute onto the Housing Studs with three 5/16-18 Flange Locknuts using a 1/2" Wrench (**Figure 9**).

Note: The 1/4-20 Bolts, and Locknuts in step 2 are pre-installed on the Guard Assembly to keep the parts in the correct order. Ensure that the Bracket stays on top of the Guard so the Bolts tighten against the Bracket and not the rubber Guard.

2. Using a 7/16" and 3/8" wrench, remove a Locknut from one of the Chipper Chute Guard Bolts, position it in the Chipper Chute, and loosely reinstall the Locknut (**Figure 9**). Repeat for the second Locknut. Fully tighten both Locknuts.

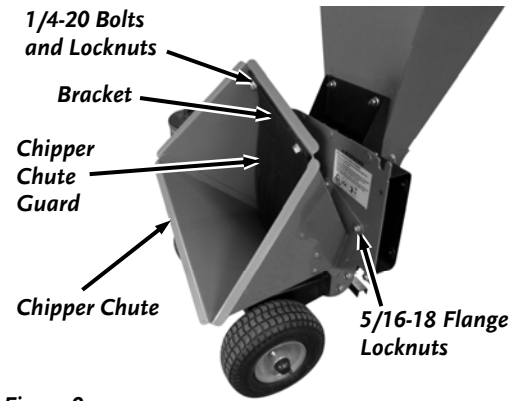

Figure 9

Attaching the Discharge Guard:

1. Secure one side of the Discharge Guard at the two mounting locations with 5/16-18 x .75 Bolts and Washers using a 1/2" Wrench (**Figure 10**).
2. Fold the Discharge Deflector over and attach the other side as in step 1.

Note: Tighten the Bolts just until the rubber guard begins to deform. No need to over tighten.

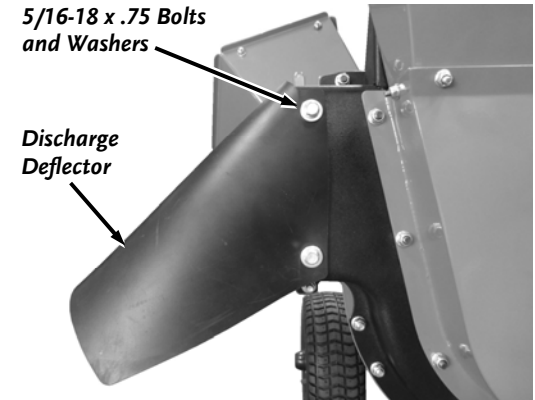

Figure 10

Adding Oil and Gasoline

NOTICE

- You **MUST** add oil before starting the Engine. This machine is shipped without oil. Traces of oil may be in the reservoir from factory testing, but you **MUST** add oil before starting the Engine. Fill the reservoir slowly, checking the level frequently to avoid overfilling.
- To get an accurate reading when checking the oil level:
 - The Engine **MUST** be level.
 - Refer to the Engine Manual for detailed information before performing the following procedures.

Engine Oil	SAE 30: above 50 degrees F; 10w-30: 10-90 degrees F; 5w-30: 30 degrees F or below
Fuel	Unleaded gasoline

NOTE: Use only the recommended high detergent Engine oil. Other types of oil could cause problems operating your machine. Please refer to your Engine Owner's Manual for more detailed oil information.

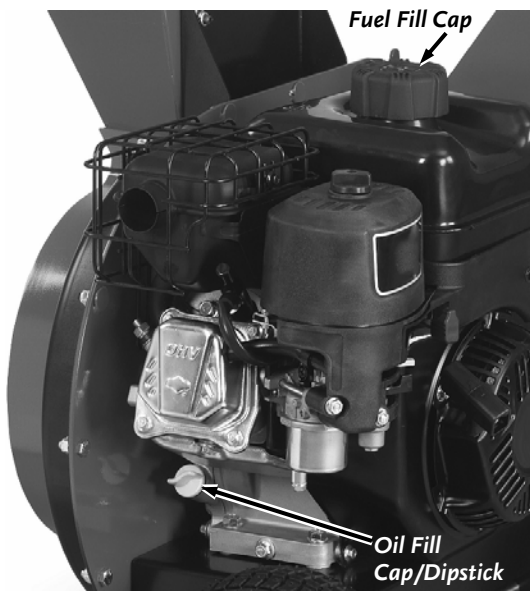

Figure 11

1. Position the machine so the Engine is level. Remove the Oil Fill Cap/Dipstick (**Figure 11**).
2. Initially add 12 oz. of the oil recommended by the Engine Manufacturer. Wait one minute for the oil to settle.
3. Check the Oil level on the Dipstick as described in the Engine Manual.
4. Continue adding a few ounces of oil at a time, rechecking the level until the oil reaches the full level as indicated in the Engine Manual. Be careful not to overfill.
5. Replace the Oil Fill Cap/Dipstick when full.
6. Remove the Fuel Fill Cap and fill the Fuel Tank with fresh, unleaded gas (with a minimum of 85 Octane) to approximately 1" to 1-1/2" below the top of the Fill Neck to allow for Fuel expansion. Be careful not to overfill. Reinstall the Fuel Fill Cap before starting the Engine. See your Engine Owner's Manual for more detailed information.

Note: To refill the Fuel Tank, turn the Engine OFF, and let the Engine cool at least five minutes before removing the Fuel Fill Cap.

Check the Tire Pressure

Tools Needed:

- Tire Pressure Gauge
- Air Compressor or Hand Pump

1. Remove the Valve Stem Protective Cap (**Figure 12**) and check the Tire pressure with a Tire Pressure Gauge.
2. Check the manufacturers recommended pressure that is stamped on the side of the Tire.

! WARNING

Do not over inflate the Tires. Inflate to the manufacturers recommended pressure.

3. If the pressure is too low, add air through the Valve Stem with an Air Compressor or Hand Pump.
4. Replace the Valve Stem Protective Cap when finished.

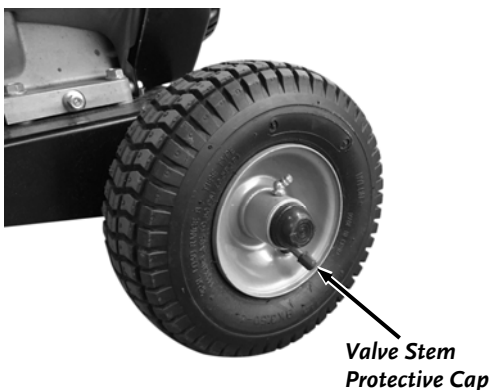

Figure 12

Chapter 3: Operating the 9.5 Chipper w/Shredder

This chapter covers the procedures for starting and stopping your new 9.5 Chipper w/Shredder and discusses basic operation features. It may be helpful to better familiarize yourself with the features of your Chipper w/Shredder by reviewing **Figure 1** in Chapter 2 before beginning the steps outlined in this chapter.

! WARNING

Read and understand the warnings listed in “Chapter 1 General Safety Rules” before operating this Chipper w/Shredder.

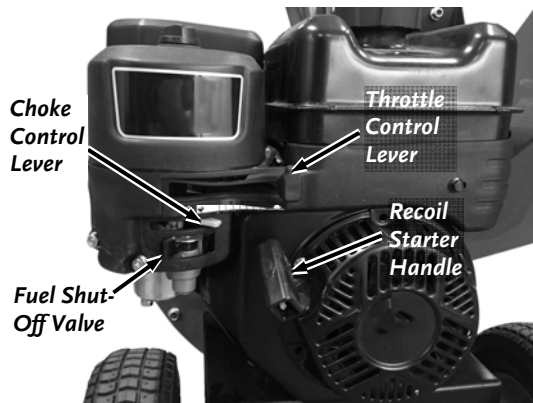

Figure 13

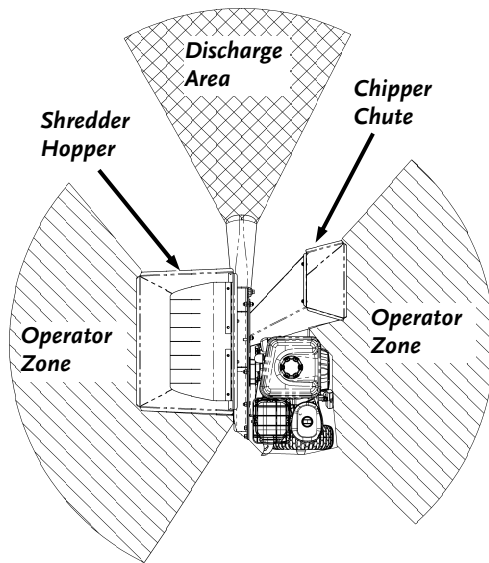

Figure 14

Starting the Engine

1. Check the Oil and Fuel level every time you use the 9.5 Chipper w/Shredder.
2. Move the Fuel Shut-Off Valve to the right to its OPEN position (**Figure 13**).
3. Check the Shredder Hopper, Chipper Chute, and Discharge Guard and remove any debris buildup from the machine as described on page 16.
4. Move the Choke Control Lever to the left to the Choke position (leave in the Run position to the right if the Engine is already warm).
5. Move the Throttle to the left, FAST (Rabbit) position.
6. Grasp the Recoil Starter Handle and slowly pull until you feel resistance, then pull the cord rapidly to start the Engine.
7. As the Engine warms up, slowly adjust the Choke to the right towards the Run position. Wait until the Engine runs smoothly before each Choke adjustment.
8. When the Engine is warmed up and running smoothly, ensure that the Choke is fully in the Run position to the right.

Note: The Throttle should always be fully to the left when Chipping/Shredding.

Stopping the Engine

Move the Throttle Control Lever all the way to the right past the SLOW (Turtle) position to the “STOP” position (**Figure 13**).

Note: Close the Fuel Shut-Off Valve when transporting or storing the 9.5 Chipper w/Shredder.

Before You Begin

- Visually check the Chipper Knife for damage each time you use the machine.
- ALWAYS operate the 9.5 Chipper w/Shredder from the Operator Zones (**Figure 14**).
- When viewed from the Chipper Chute side the Flywheel turns in a clockwise direction.
- NEVER assume you know where the Chipper Knife is. You do not know where it is.
- ALWAYS stop the Engine when leaving the Operating Zone or when moving the machine.

Using the Chipper Chute

The Chipper Chute is designed to chip larger, heavier materials that the Shredder Hopper isn't designed to handle. The revolving Chipper Knife mounted on a Flywheel turns branches fed into the Hopper into "chips". The Chipper can chip twigs and branches ranging in size from 1/2" to 3" in diameter. Cut your materials into manageable lengths before feeding them into the Chipper Chute.

- Do not force material into the Chipper. If the machine does not chip well, the Chipper Knife may need sharpening or to be replaced.
- Extremely hard knots may not process very well. Push any short stubs that have not self-fed through the Chipper, with the next branch to be chipped.
- Overloading the Chipper Chute will cause the Flywheel speed to decrease. If you hear the Engine RPM decreasing, stop feeding material into the Chipper Chute until the Engine has returned to full speed.
- Your 9.5 Chipper w/Shredder can process dry or green material. Green material will process quicker and easier than dry material. Soft wood processes easier than hard wood.
- It is best to trim off any side twigs from the main branch that you are chipping.
- When chipping branches, sometimes a tail will remain at the end of a branch. To avoid this, rotate the branch while feeding it into the Chipper Chute. Rotating the branch as you feed it into the machine will improve chipping performance.
- Use caution with small diameter green saplings and branches less than 1" in diameter. Chip these grouped or bundled together to provide support for each other. If the material is 1" or larger, feed only one at a time into the Chipper Chute.
- NEVER allow processed material to build up within 3" of the Discharge opening. Move the 9.5 Chipper w/Shredder or the pile as needed. Failure to do so could result in unnecessary jamming of the machine.
- To move a pile of processed material, first shut off the Engine, and use a spade, rake, or long handle tool; NEVER use your hands or feet!
- Make sure the 9.5 Chipper w/Shredder finishes processing material before shutting the Engine off.

Using the Shredder Hopper

The Shredder Hopper can process hard wood branches up to 1/2" in diameter and softer organic material up to 2-3/8" in diameter. You can shred most organic materials. A flex guard, or blowback shield is attached to the Hopper. You must push material past this flap (using a branch if necessary) in order to enter the main Shredding Chamber where revolving steel Hammers do the shredding.

WARNING

The Hammers within the Shredding Chamber can tug suddenly at material fed into the Shredder Hopper. Do not hold on tightly to branches and vines, and do not feed material straight down into the Hopper with your arm pointing downward toward the opening. Instead, keep your arms parallel to the ground and several inches above the top edge of the Hopper.

- Due to the wide variety of materials that you can shred, and their very different physical characteristics, only feed limited quantities of any material into the Shredder Hopper at first. Increase the amount and length of material if you find that the material is processing without any difficulty. Your judgment and operator experience is very important.
- Be sure not to overload the machine by feeding too much material into the Hopper at one time. If you hear the speed of the Engine decreasing, stop feeding material into the machine at once. Do not resume feeding the machine until the Engine has returned to full speed.
- You can feed several small branches into the Shredder Hopper at once providing their combined diameter is less than 1/2". Cut branches so they are shorter than 3 feet to make them more manageable.
- Allow green materials to dry before processing or alternate processing green/wet materials with dry materials to avoid clogging. If wet materials begin to clog, shred a stick to clear the material through. The shredding capacity is 1/2" hard woody material. For clearing a clog, you can intermittently shred a larger stick up to 1" diameter.

MATERIALS BEST SUITED FOR SHREDDING			
Leaves	Flowers	Corn Stalks	Roots
Soil	Palm frond tops	Grass clippings	Garden debris
Potato vines	Straw and Hay	Hedge clippings	Tomato vines
Manure	Kitchen Waste	Small branches	

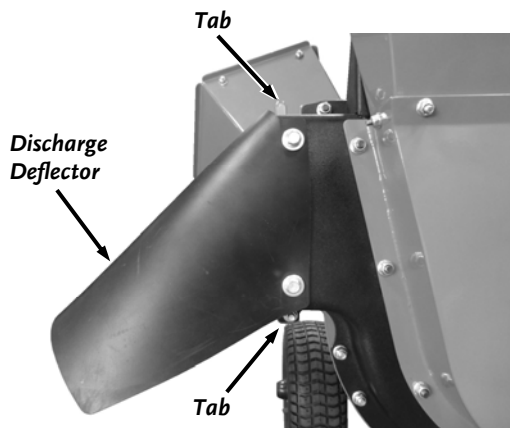

Figure 15

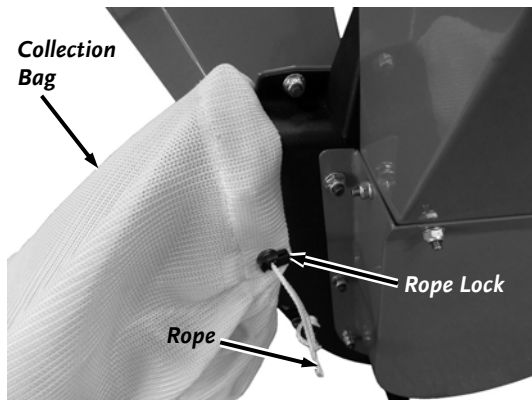

Figure 16

Using the Collection Bag

An optional Collection Bag is provided with your machine.

1. Install the open end of the Collection Bag over the rubber discharge Deflector and hook it over the metal housing tabs above and below the Discharge Deflector (**Figure 15**).
2. Cinch the bag tightly by squeezing the locking Button and pushing it against the machine as you pull the String. Release the Button to secure the Bag (**Figure 16**).

Note: Chip and shred as normal. Make sure to empty the Collection Bag before it is completely full.

To Free a Clog

! WARNING

Before performing any maintenance procedure or inspection, stop the Engine, wait five minutes to allow all parts to cool. Disconnect the Spark Plug Wire, keeping it away from the Spark Plug.

1. Remove any material left in the Chipper Chute and Shredder Hopper with a wooden stick.
2. Check the Discharge Opening for clogs. If it is clogged, clear it with a stick.
3. Start the machine and allow any remaining material to discharge.
4. If you have been shredding wet/green materials the clog may be near the shredder housing inlet. Shred a wood stick of up to 1" diameter to clear the clogged wet material.
5. If the clog does not clear repeat the above process.
6. Be certain the cutting chamber is clear before trying to process more material.

Chapter 4: Maintaining The 9.5 Chipper w/Shredder

Regular maintenance is the way to ensure the best performance and long life of your machine. Please refer to this manual and the Engine Manufacturer's Owner's Manual for maintenance procedures. Service intervals listed in the checklist below supersede those listed in the Engine Manufacturer's Owner's Manual.

WARNING

Before performing any maintenance procedure or inspection, stop the Engine, wait five minutes to allow all parts to cool. Disconnect the Spark Plug Wire, keeping it away from the Spark Plug.

Regular Maintenance Checklist

PROCEDURE	BEFORE EACH USE	EVERY 25 HOURS
Check Engine Oil Level	▲	
Check General Equipment Condition	▲	
Clean Engine Exterior & Cooling Fins	▲	
Inspect Knife for damage and sharpness	▲	
Check Air Filter, Clean or Replace as Needed	▲	
Check Tire Pressure	▲	
Change Engine Oil	1 st time 5 hrs	▲
Check Knife Attachment Screws		▲
Check Hammers/Spacers for Wear, Reverse or Replace as Needed		▲
Inspect Spark Plug, Replace as Needed		▲

Removing and Replacing the Engine Oil

Tools and Supplies Needed:

- 10mm Wrench
- Rags and approved Container (for waste oil)
- Small funnel
- Engine Oil (see your Engine Manual for Oil specifications)

Note: Drain the oil when the Engine is warm; warm oil drains quickly and completely.

1. Set the machine on a level surface, place a container between the wheels under the unit toward the right side, and remove the Oil Fill/Dipstick on the left side of the machine (**Figure 17**).
2. On the right side of the engine, use a 10mm Wrench to remove the Oil Drain Plug allowing the used oil to drain completely through the drain hole into an approved Waste Oil Container (**Figure 18**).
3. Replace the Oil Drain Plug, and refill with new oil (see "**Adding Oil and Gasoline**" on page 11).

Note: Be sure to use environmentally safe disposal procedures in the disposing of the used oil.

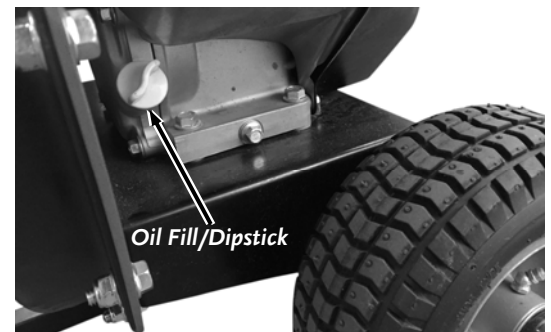

Figure 17

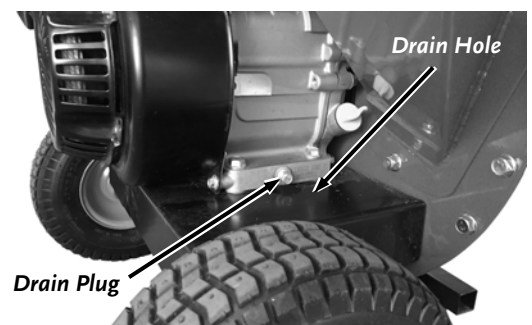
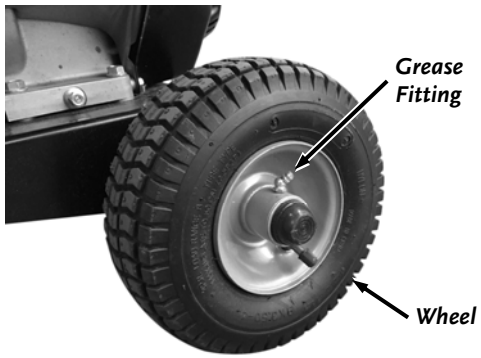

Figure 18



Greasing the Wheel Bearings

Tools and Supplies Needed:

- Grease Gun
- Lithium Grease
- Clean Cloth

1. Wipe all dirt, etc., from the Grease Fittings on both Wheels with a clean cloth (**Figure 19**).
2. Apply no more than three pumps of quality general-purpose lithium grease with a hand-pumped grease gun to the Grease Fitting on each Wheel.

Figure 19

Replacing the Chipper Knife

The 9.5 Chipper w/Shredder is shipped with a sharp Chipper Knife and depending upon material being chipped we've found it can remain acceptably sharp for 40 plus hours. When you notice diminished self-feeding, it is time to replace the knife. You may also choose to have the knife sharpened instead as described on the next page.

Tools and Supplies needed:

- 1/2" Wrench
- 1/2" Deep Socket
- 3/16" Allen Wrench
- Awl
- Gloves

1. Use a 1/2" Wrench to remove the nine Locknuts that secure the Hammermill Housing and Shredder Hopper Assembly (**Figure 20**). Lift the Assembly off the machine.
2. Use a 1/2" Wrench to remove the three Locknuts that secure the Chipper Chute and lift it off the machine (**Figure 21**).
3. Rotate the Flywheel until the Locknut is visible through the Locknut Access Hole. (**Figure 22**).
4. Clean out the heads of the Allen Screws with an awl or sharp tool (**Figure 23**).
5. Insert a 3/16" Allen wrench into the head of the screw and a 1/2" Deep Socket on the Locknut through the Locknut Access Hole (**Figure 22**) and remove the Locknut and Screw.

Note: Take care not to drop the Allen Screw or Locknut into the machine.

6. Rotate the Hammer Mill Assembly until the outer Locknut is visible through the Locknut Access Cutout.
7. Repeat Steps 6 and 7 for the remaining Screw and Locknut.
8. Remove the dull or damaged Knife and visually inspect the Knife mounting area and be sure they are clean. Metal burrs may need filing so that the replacement Knife will be able to mount flush against the Flywheel.
9. Install a new or sharpened Knife and finger tighten the Allen Screws and Locknuts.

Note: New Allen Screws and Locknuts are provided with each new Chipper Knife.

10. Using a 3/16" Allen Wrench on the Screw and a 1/2" Deep Socket on the Locknut, tighten the hardware to secure the Chipper Knife.
11. Double-check both Screws for tightness one more time.
12. Reinstall the Chipper Hopper, Hammer Mill Housing/Shredder Hopper Assembly.

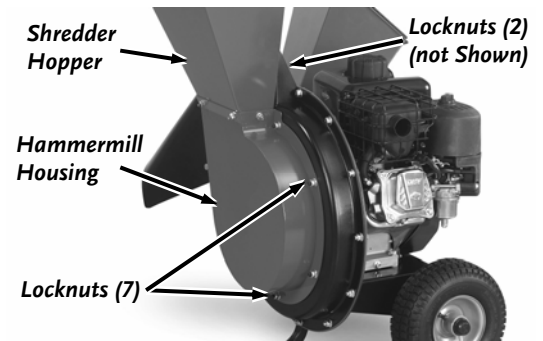

Figure 20

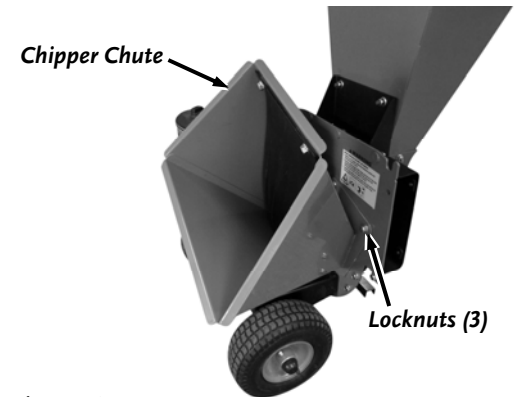

Figure 21

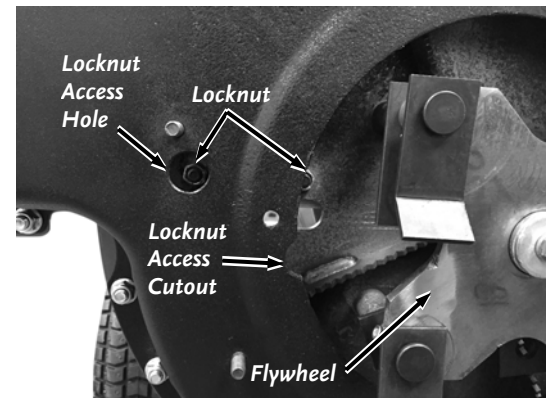

Figure 22

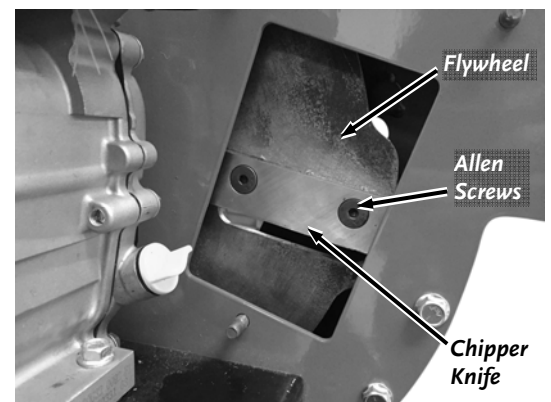

Figure 23

Knife Sharpening

- You should never attempt to sharpen the Chipper Knife freehand; take the Knife to a machine shop for proper sharpening.
- It is extremely important to consistently maintain the 45-degree angle for proper performance.
- Excessive heat generated during the sharpening process will damage Knives and weaken the metal.
- How many times a Knife can be sharpened is determined by how much material needs to be taken off to sharpen or to compensate for dents or gouges.
- A new Chipper Knife has a $5/16$ " measurement between the short side bevel edge and the Knife mounting holes (**Figure 24**).

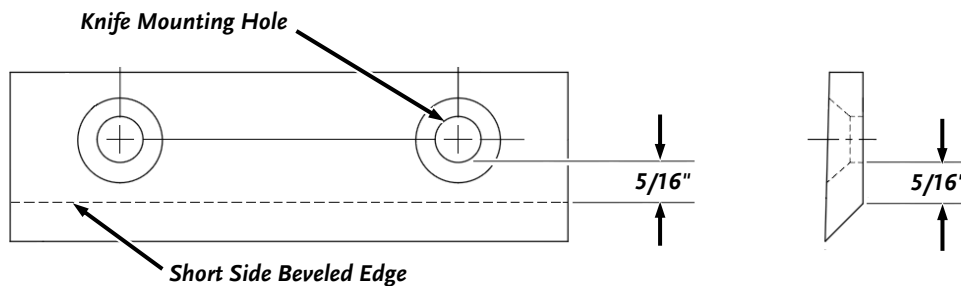

Figure 24: New Knife

- The knife should never be sharpened to the extent that more than $3/32$ " is taken off this measurement.
- Once this measurement is below $7/32$ " (**Figure 25**), or if you are unable to remove dents or gouges with these guidelines, replace the Knife.

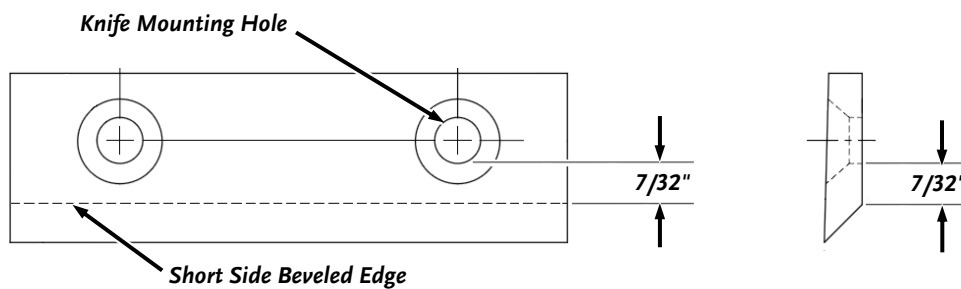

Figure 25: Sharpened Knife

Maintaining the Shredder Hammers

When the hardened steel Hammers become dull or round on the cutting edge, they should be rotated or reversed.

Note: The four flat Hammers have four cutting edges and the four J Hammers have two that may be used before replacement is necessary. To reverse the Hammers, proceed as follows:

Tools Required

- 1/2" Wrench
- 3/8" Wrench
- 5/32" Allen Wrench

1. Remove the Hammermill Housing/Shredder Hopper Assembly. See "Replacing the Chipper Knife" in this Chapter.
2. Use a 5/32" Allen Wrench and a 3/8" Wrench to remove the Screw and Locknut from one of the Short Spacers (**Figure 26**).
3. Remove the Hammer Shaft, Spacers and Hammers.
4. Flip the J Hammer and Flat Hammer 180 degrees making sure the order is correct (J Hammer outermost).

Note: Be sure you reinstall the Hammers and Spacers in exactly the same order that they were removed.

5. Reinstall the Screw and locknut through the Short Spacer and the Hammer Pin.
6. Repeat steps 2 through 4 for the other three sets of Hammers. Confirm that two of the J Hammers are facing out and the opposite two are facing in (**Figure 27**). Correct them if needed.
7. Reinstall the Hammer Mill Housing/Shredder Hopper Assembly.

Flywheel Maintenance

A flywheel removal tool is available through Generac Power Systems to allow easy removal of the flywheel (**Figure 27**). Please call us at 1-888-545-6576 to order the tool.

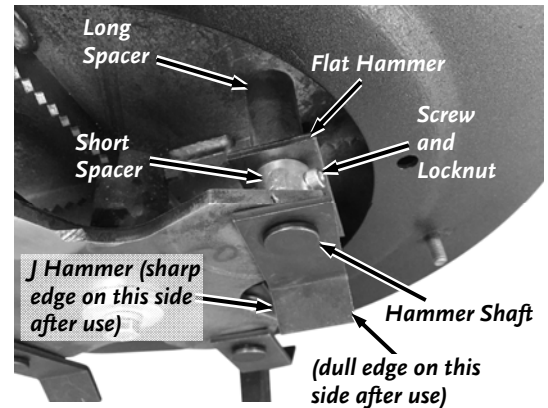

Figure 26

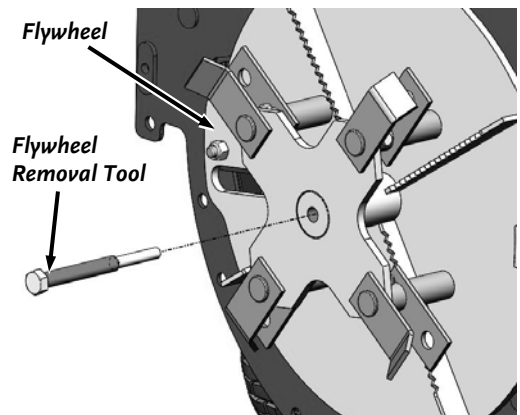

Figure 27

Chapter 5: Troubleshooting

Most problems are easy to fix. Consult the Troubleshooting Table below for common problems and their solutions. If you continue to experience problems, contact us at 1-888-545-6576 for support.

WARNING

Shut down the Engine, remove the Spark Plug Wire, and wait five minutes before performing any maintenance procedure or inspection on the Chipper w/Shredder.

Troubleshooting Table

SYMPTOM	POSSIBLE CAUSE
<i>Recoil will not pull out or is difficult to pull.</i>	<ul style="list-style-type: none"> ⇒ Remove un-process material from the Chipper Chute and Shredder Hopper and remove any built-up debris in the Discharge opening. ⇒ There may be an oil compression lock in the cylinder. Take out the Spark Plug; hold a rag over the Spark Plug hole and pull the Recoil Cord several times to blow out any oil in the Cylinder. Wipe off the Spark Plug and reinstall it. ⇒ Check the Engine oil level; the Engine may be seized. ⇒ The Recoil may be broken or jammed. Call us at 1-888-545-6576.
<p><i>The Engine will not start.</i></p> <p><i>(Please refer to the Engine Owner's Manual for Engine-specific procedures.)</i></p>	<ul style="list-style-type: none"> ⇒ Check the oil and gas level. ⇒ Make sure that the Fuel Shut-Off is in the ON position. ⇒ Check that the Spark Plug Wire is attached. ⇒ The Air Filter may be dirty; change it following the procedure in the Engine Owner's Manual. ⇒ The gas may be old; change it if necessary. Use a fuel stabilizer if you keep gas longer than one month. ⇒ Check the Throttle and Choke settings, adjustment and travel. ⇒ The Spark Plug may be dirty or cracked; change it if necessary. If it's oily, leave it out, hold a rag over the Plug Hole and pull the Recoil Cord several times to blow out any oil in the Cylinder, then wipe off the Plug and reinsert it. Never use a cracked Spark Plug as serious damage could result. ⇒ If your Engine still won't start, call us at 1-888-545-6576.
<p><i>The Engine lacks power or is not running smoothly.</i></p> <p><i>(Please refer to the Engine Owner's Manual for engine-specific procedures.)</i></p>	<ul style="list-style-type: none"> ⇒ Make sure the Choke Lever is all the way to the RUN position (right). ⇒ Make sure that the Throttle Lever is all the way to the left (FAST- Rabbit). ⇒ The Air Filter may be dirty; change it following the procedure in the Engine Owner's Manual. ⇒ The Spark Plug may be dirty or cracked; change it if necessary. If it's oily, leave it out, hold a rag over the Plug Hole and pull the Recoil Cord several times to blow out any oil in the Cylinder, then wipe off the Plug and reinsert it. Never use a cracked Spark Plug as serious damage could result. ⇒ The gas may be old; change it if necessary. Use a fuel stabilizer if you keep gas longer than one month. ⇒ The Engine oil may be dirty. Change it if necessary. ⇒ Check that the Cooling Fins are clean and free of debris. Clean as needed. ⇒ If your Engine still lacks power, call us at 1-888-545-6576.

Troubleshooting Table (Continued)

WARNING

Shut down the Engine, remove the Spark Plug Wire, and wait five minutes before performing any maintenance procedure or inspection on the Chipper w/Shredder.

SYMPTOM	POSSIBLE CAUSE
<p><i>Engine smokes.</i></p> <p><i>(Please refer to the Engine Owner's Manual for engine-specific procedures.)</i></p>	<p>⇒ Check the oil level and adjust as needed.</p> <p>⇒ You may be operating the machine on too great an incline. The machine should be level.</p> <p>⇒ The Air Filter may be dirty; change it following the procedure in the Engine Owner's Manual.</p> <p>⇒ You may be using the wrong oil - too light for the temperature. Refer to your Engine Owner's Manual for detailed information.</p> <p>⇒ Check that the Cooling Fins are clean and free of debris. Clean as needed.</p> <p>⇒ If your Engine still smokes, call us at 1-888-545-6576.</p>
<p><i>Shredding and chipping action seems too slow.</i></p>	<p>⇒ Check for a dull or damaged Knife; sharpen or replace the Knife.</p>
<p><i>The machine has excessive vibration.</i></p>	<p>⇒ Check for a dull or damaged Knife; sharpen or replace the Knife.</p> <p>⇒ The Hammermill is out of balance. Check for any missing or broken Hammers or Spacers; replace if necessary.</p> <p>⇒ The Knife may not be seated properly. Loosen the Knife mounting screws, reset the Knife, and tighten the screws.</p> <p>⇒ If your machine still exhibits excessive vibration, call us at 1-888-545-6576.</p>
<p><i>When chipping, the branch seems to vibrate excessively and "hammers" my hands.</i></p>	<p>⇒ The Knife is dull; sharpen or replace it.</p>
<p><i>Debris builds up in the cutting chamber</i></p>	<p>⇒ Alternate shredding dry material with wet/green material.</p> <p>⇒ Shred a wood stick of up to 1" diameter to clean out the build-up.</p>

Chapter 6: Parts Lists and Schematic Diagrams

Parts List – 9.5 CHIPPER W/SHREDDER

Note: Part numbers listed are available through Generac Power Systems.

<u>Ref#</u>	<u>Part#</u>	<u>Description</u>	<u>Ref#</u>	<u>Part#</u>	<u>Description</u>
1	33332	Nut, Nylon Lock, Flanged, 5/16-18	26	36509	Spacer, Hammer, Short W/Hole
2	36511	Housing, Flywheel	27	36510	Screw, Hex, 10-24 X 1.12", 18-8 S/S
3	37499	Sideplate, Housing, w/Label	28	11873	Nut, Nylon Lock 10-24
4	33352	Bolt, Hex, Flange, 5/16-18 X 1.5"	29	37496	Hopper, Shredder, w/Labels
5	37495	Engine, B&S, 9.5 TQ, M/S, 50st, w/Labels	30	36518	Housing, Hammermill
6	35032	Washer, Lock, 5/16, GR8 Split, ZP	31	36503	Screw, Button Head Flange, 1/4-20 X 5/8", ZP
7	36502	Bolt, HCS, 5/16-24 X 1.75", GR5, ZP	32	33331	Nut, Nylon Lock, Flanged, 1/4-20
8	36501	Spacer, Engine Mount	33	36521	Bolt, Hex Flange, 10-24 X .5", ZP
9	15488	Nut, Push Cap 5/8", Black	34	36526	Support, Hopper Guard
10	36520	Wheel, 9" X 3.5"	35	36525	Guard, Shredder
11	36497	Axle	36	36515	Plate, Blowback
12	36498	Spacer, Wheel	37	36544	Support, Guard, Hopper
13	36499	Leg, Support	38	35023	Bolt, Hex, Flange, 5/16-18 X .75"
14	36496	Base, Engine	39	35038	Nut, Nylon Lock, Flange, 10-24, ZP
15	10638	Square Key	40	36519	Deflector, Discharge
16	18081	Washer, Medium Split Lock, 3/8"	41	11238	Washer, Flat, 1/4" USS
17	18882	Bolt, HCS, 3/8-24 X 2.25", GR 8, YZP	<u>Not Shown</u>		
18	36504	Flywheel, Balanced W/Knife	13758		Label, Check Oil
19	37498	Chute, Chipper, w/Label	18887		Label, Hot Surface
20	36514	Guard, Chipper	34141		Label, Logo, Silver, 5.75"
21	33804	Washer, .344" ID X .88" OD X .12"	36529		Label, Warning, Safety
22	36507	Hammer, J	36530		Label, Warning, Discharge
23	36506	Hammer, Flat	36527		Bag, Collection, 2.5 Bushel
24	36505	Shaft, Hammer	36537		Knife Kit
25	36508	Spacer, Hammer, Long			

Schematic – 9.5 CHIPPER W/SHREDDER

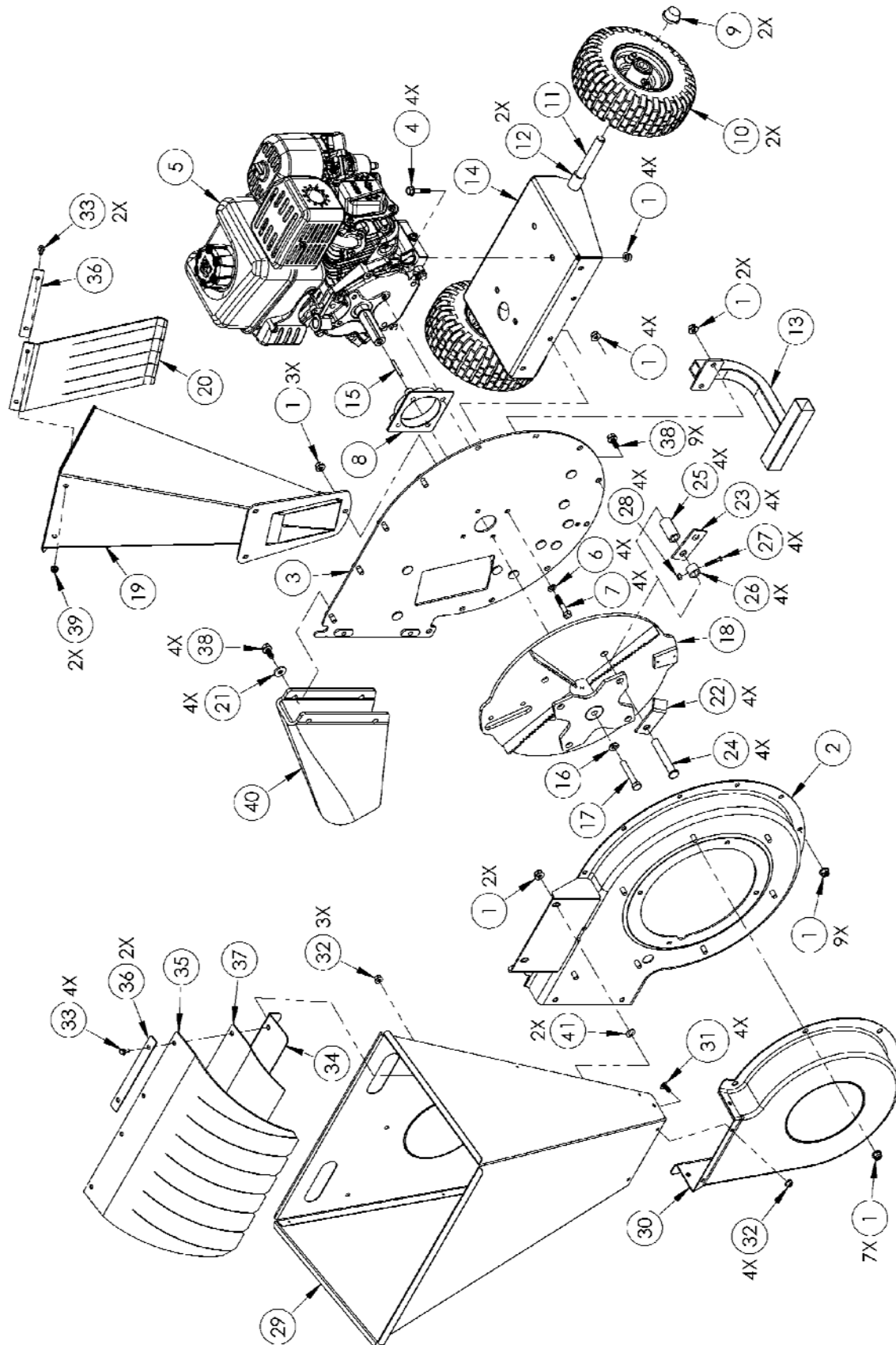

Notes:



GENERAC® 9.5 CHIPPER W/SHREDDER

2-Year Limited Warranty

Terms and Conditions

The **GENERAC®** CHIPPER W/SHREDDER is warranted for two (2) years against defects in materials or workmanship when put to ordinary and normal consumer use; ninety (90) days for any other use.

For the purposes of all the above warranties, "ordinary and normal consumer use" refers to non-commercial residential use and does not include misuse, accidents or damage due to inadequate maintenance.

Generac Power Systems certifies that the **GENERAC®** CHIPPER W/SHREDDER is fit for ordinary purposes for which a product of this type is used. Generac Power Systems however, limits the implied warranties of merchantability and fitness in duration to a period of two (2) years in consumer use, ninety (90) days for any other use.

The 2-Year Limited Warranty on the **GENERAC®** CHIPPER W/SHREDDER starts on the date the machine ships from our factory. The 2-Year Limited Warranty is applicable only to the original owner.

The warranty holder is responsible for the performance of the required maintenance as defined by the manufacturer's owner's manuals. The warranty holder is responsible for replacement of normally wearing parts such as the knife, hammers, and hammer shafts. Attachments and accessories to the machine are not covered by this warranty.

During the warranty period, the warranty holder is responsible for the machine transportation charges, if required. During the warranty period, warranty parts will be shipped by standard method at no charge to the warranty holder. Expedited shipping of warranty parts is the responsibility of the warranty holder.

SOME STATES DO NOT ALLOW LIMITATIONS ON THE LENGTH OF IMPLIED WARRANTIES, SO THE ABOVE LIMITATIONS MAY NOT APPLY TO YOU.

Generac Power Systems shall not be liable under any circumstances for any **incidental or consequential damages or expenses** of any kind, including, but not limited to, cost of equipment rentals, loss of profit, or cost of hiring services to perform tasks normally performed by the **GENERAC®** CHIPPER W/SHREDDER.

SOME STATES DO NOT ALLOW THE EXCLUSION OR LIMITATION OF INCIDENTAL OR CONSEQUENTIAL DAMAGES, SO THE ABOVE LIMITATIONS MAY NOT APPLY TO YOU.

THIS WARRANTY GIVES YOU SPECIFIC LEGAL RIGHTS, AND YOU ALSO HAVE OTHER RIGHTS, WHICH VARY FROM STATE TO STATE.

Daily Checklist for the 9.5 Chipper w/Shredder

To help maintain your 9.5 Chipper w/Shredder for optimum performance, we recommend you follow this checklist each time you use your Chipper w/Shredder.

WARNING

Before performing any maintenance procedure or inspection, stop the Engine, wait five minutes to allow all parts to cool. Disconnect the Spark Plug Wire, keeping it away from the Spark Plug.

- Check the Engine oil and Fuel Tank level.
- Check that Engine is clean of debris.
- Remove any unprocessed material from the Chipper Chute and Shredder Hopper.
- Check the general condition of the Chipper w/Shredder, e.g.; nuts, bolts, welds, etc.
- Check Tire Pressure and wear.
- Check the Chipper Knife for tightness, nicks and wear.
- Check the Blowback Guards and Discharge Guard for wear and damage.

End of Season and Storage

WARNING

Before performing any maintenance procedure or inspection, stop the Engine, wait five minutes to allow all parts to cool. Disconnect the Spark Plug Wire, keeping it away from the Spark Plug.

- Change the Engine oil.
- Clean or replace the Air Filter.
- Check the Chipper Knife and Hammers for nicks and wear.
- Remove any debris wrapped around the Hammers/Spacers.
- If your 9.5 Chipper w/Shredder will be idle for more than 30 days, we recommend using a gas stabilizer. This will prevent sediment from gumming up the Carburetor. If there is dirt or moisture in the gas or tank, remove it by draining the tank. Completely fill the tank with fresh, unleaded gas and add the appropriate amount of stabilizer or gasoline additive. Run the Engine for a short time to allow the additive to circulate. Close the Fuel Shut-Off Valve to prevent carburetor overflow and leakage.
- Clean the exterior of the unit to remove all dirt, grease, and any other foreign material. To prevent rust, touch up painted surfaces that have been scratched or chipped.
- Be sure all nuts, bolts, and screws are securely fastened.
- Remove the Spark Plug and pour about 1 ounce of motor oil into the Cylinder hole. Replace the Plug and crank the Engine over a couple of times using the Pull Cord. This will coat the piston and seat the valves to prevent moisture buildup.
- If possible, store the Chipper w/Shredder in a dry, protected place. If it is necessary to store the machine outside, after the 9.5 Chipper w/Shredder has cooled, cover the machine with a suitable protective cover that does not retain moisture. Do not use plastic as this material cannot breathe; it also allows condensation to form, which will cause your machine to rust.



75 MEIGS ROAD, P.O. BOX 25, VERGENNES, VERMONT 05491