

# DR® 11.5 SELF-FEEDING CHIPPER

## SAFETY & OPERATING INSTRUCTIONS



Serial No. \_\_\_\_\_

Order No. \_\_\_\_\_

**Original Language**

DR Power Equipment  
Toll-free phone: 1-800-DR-OWNER (376-9637)  
Fax: 1-802-877-1213  
Website: [www.DRpower.com](http://www.DRpower.com)

**! DANGER**

Read and understand this manual and all instructions before operating or servicing this DR 11.5 Self-Feeding Chipper.

## Table of Contents

|                                                              |    |
|--------------------------------------------------------------|----|
| Chapter 1: General Safety Rules.....                         | 3  |
| Chapter 2: Setting Up the DR 11.5 SELF-FEEDING CHIPPER ..... | 10 |
| Chapter 3: Operating Your DR 11.5 SELF-FEEDING CHIPPER ..... | 16 |
| Chapter 4: Maintaining The DR 11.5 SELF-FEEDING CHIPPER..... | 20 |
| Chapter 5: Troubleshooting .....                             | 31 |
| Chapter 6: Chipper Accessories .....                         | 33 |
| Chapter 7: Parts List and Schematic Diagrams.....            | 36 |

### ***Conventions used in this manual***

---

#### **DANGER**

This indicates a hazardous situation, which, if not followed, will result in death or serious injury.

---

---

#### **WARNING**

This indicates a hazardous situation, which, if not avoided, could result in death or serious injury.

---

---

#### **CAUTION**

This indicates a hazardous situation, which, if not avoided, could result in minor or moderate injury.

---

---

#### **NOTICE**

This information is important in the proper use of your machine. Failure to follow this instruction could result in damage to your machine or property.

---

### ***Serial Number and Order Number***

A Serial Number is used to identify your machine and is located on the Serial Number Label on your machine. An Order Number is used to check and maintain your order history and is located on your packing slip. For your convenience and ready reference, enter the Serial Number and Order Number in the space provided on the front cover of this manual.

### ***Additional Information and Potential Changes***

DR Power Equipment reserves the right to discontinue, change, and improve its products at any time without notice or obligation to the purchaser. The descriptions and specifications contained in this manual were in effect at printing. Equipment described within this manual may be optional. Some illustrations may not be applicable to your machine.

## Chapter 1: General Safety Rules

### **WARNING**

- Read this safety & operating manual before you use the DR 11.5 SELF-FEEDING CHIPPER. Become familiar with the operation and service recommendations to ensure the best performance from your machine.
- Thoroughly inspect the area in which you will be working and remove all foreign objects. Look for rope, wire, etc., and remove these objects before chipping. Inserting these objects into the chipper hopper could damage the machine and/or cause injury.
- This is a high-powered machine, with moving parts operating with high energy at high speeds. You must use proper clothing and safety gear when operating this machine to prevent or minimize the risk of severe injury. This machine can crush, grind, cut, and sever parts of your body if they enter the inlet or discharge area of your chipper.

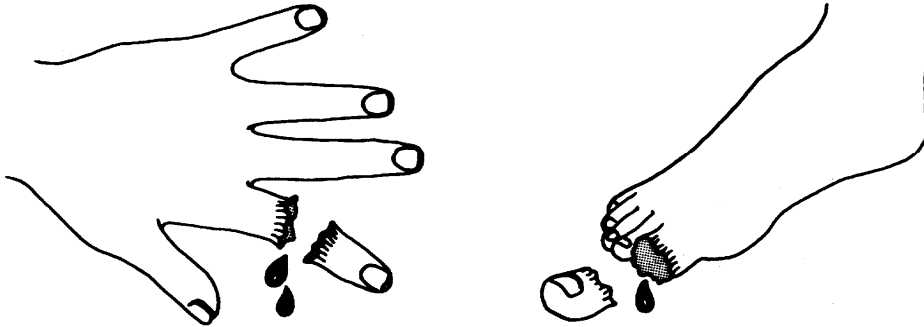

### Labels

Your DR 11.5 SELF-FEEDING CHIPPER carries prominent labels as reminders for its proper and safe use. Shown below are copies of all the safety and operation labels that appear on the equipment. Take a moment to study them and make a note of their location on your DR 11.5 SELF-FEEDING CHIPPER as you assemble and before you operate the unit. Replace damaged or missing safety and operation labels immediately.

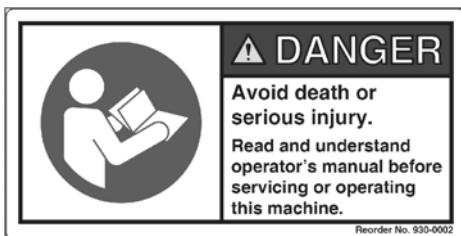

#241801



#241851



#241811



#241991

|                                     |                                                                                                                                     |
|-------------------------------------|-------------------------------------------------------------------------------------------------------------------------------------|
|                                     | <b>⚠ WARNING</b>                                                                                                                    |
|                                     | Rotating parts inside can cause severe injury. Improper use can cause fire and clutch damage.                                       |
|                                     | Keep hands, body parts and loose clothing clear of this area while machine is running and parts are moving.                         |
|                                     | Do NOT start or operate machine without all guards in place.                                                                        |
|                                     | Shut down engine, wait for all moving parts to come to a complete stop, remove spark plug wire, then wait 5 minutes before opening. |
| <small>Reorder No. 930-0004</small> |                                                                                                                                     |

#241821

|                                     |                                                                                                                                     |
|-------------------------------------|-------------------------------------------------------------------------------------------------------------------------------------|
| <b>⚠ WARNING</b>                    |                                                                                                                                     |
|                                     | Rotating knife and flywheel can cause severe injury.                                                                                |
|                                     | Do NOT start or operate machine without all guards in place.                                                                        |
|                                     | Shut down engine, wait for all moving parts to come to a complete stop, remove spark plug wire, then wait 5 minutes before opening. |
| <small>Reorder No. 930-0001</small> |                                                                                                                                     |

#242001

|                                     |                                                                                             |
|-------------------------------------|---------------------------------------------------------------------------------------------|
|                                     | <b>⚠ WARNING</b>                                                                            |
|                                     | High speed discharge and debris can cause severe injury.                                    |
|                                     | Stand clear of the discharge chute while machine is running and parts are moving.           |
|                                     | Keep bystanders, children, and pets 100 ft. from machine while in use.                      |
|                                     | Always wear approved safety glasses when using this machine.                                |
|                                     | Be aware of your surroundings, wind can cause the discharge and debris to change direction. |
| <small>Reorder No. 930-0010</small> |                                                                                             |

#241831

**WARNING: Check Oil Before Starting Engine**

#137581

|                                     |                                                                                                  |
|-------------------------------------|--------------------------------------------------------------------------------------------------|
|                                     | <b>⚠ DANGER</b>                                                                                  |
|                                     | Avoid death or serious injury.                                                                   |
|                                     | Do NOT tow this machine faster than 10 MPH. This machine is not legal for street or highway use. |
| <small>Reorder No. 930-0008</small> |                                                                                                  |

#242041 (with Pin Hitch Package only)

|                                                                                                                                                                              |                                                                                                                                                         |                                                                                                                                                                                  |                                                                                                                                                              |                                                                                                                                                                                                                    |
|------------------------------------------------------------------------------------------------------------------------------------------------------------------------------|---------------------------------------------------------------------------------------------------------------------------------------------------------|----------------------------------------------------------------------------------------------------------------------------------------------------------------------------------|--------------------------------------------------------------------------------------------------------------------------------------------------------------|--------------------------------------------------------------------------------------------------------------------------------------------------------------------------------------------------------------------|
| <b>⚠ DANGER</b>                                                                                                                                                              |                                                                                                                                                         |                                                                                                                                                                                  |                                                                                                                                                              |                                                                                                                                                                                                                    |
| <b>Avoid death or serious injury.</b>                                                                                                                                        |                                                                                                                                                         |                                                                                                                                                                                  |                                                                                                                                                              |                                                                                                                                                                                                                    |
| <p>Rotating cutting blades.</p> <p>Do NOT insert hands, body parts, or metal objects in the hopper or discharge chute while the machine is running and parts are moving.</p> | <p>Shut down engine, wait for all moving parts to come to a complete stop, remove spark plug wire, then wait 5 minutes before clearing obstruction.</p> | <p>Keep hands, all body parts, and loose clothing away from moving parts.</p> <p>Always wear approved safety glasses, hearing protection and gloves when using this machine.</p> | <p>Keep stones, nails, and other objects except branches out of the hopper.</p> <p>Keep bystanders, children and pets 100 ft. from machine while in use.</p> | <p>Do NOT operate machine without the hopper, blow back shield, discharge chute and all guards securely in place.</p> <p>Read and understand the operator's manual before servicing or operating this machine.</p> |
|                                                                                                                                                                              |                                                                                                                                                         |                                                                                                                                                                                  |                                                                                                                                                              |                                                                                                                                                                                                                    |
| <small>Reorder No. 930-0013</small>                                                                                                                                          |                                                                                                                                                         |                                                                                                                                                                                  |                                                                                                                                                              |                                                                                                                                                                                                                    |

#241841

## Protecting Yourself and Those Around You

### **WARNING**

This is a high-powered machine, with moving parts operating with high energy at high speeds. You must operate the machine safely. Unsafe operation can create a number of hazards for you, as well as anyone else in the nearby area. Always take the following precautions when using this machine:

- Always wear protective goggles or safety glasses with side shields while chipping to protect your eyes from possible thrown debris.
- Avoid wearing loose clothing or jewelry, which can catch on moving parts or the material fed into the chipper hopper.
- We recommend wearing gloves while chipping. Be sure your gloves fit properly and do not have loose cuffs or drawstrings.
- Wear shoes with non-slip treads when using your chipper. If you have safety shoes, we recommend wearing them. Do not use the machine while barefoot or wearing open sandals.
- Wear long pants while operating the chipper.
- Use ear protectors or ear plugs rated for at least 20 dba to protect your hearing.
- Never allow people who are unfamiliar with these instructions to use the chipper. Allow only responsible individuals who are familiar with these rules of safe operation to use your machine.
- Never place your hands, feet, or any part of your body in the chipper hopper, discharge opening, or near or under any moving part while the machine is running. Keep area of discharge clear of people, animals, buildings, glass, or anything else that will obstruct clear discharge, cause injury, or damage. Wind can also change discharge direction, so be aware. If it becomes necessary to push material into the chipper hopper, use a small diameter stick, not your hands.
- Keep bystanders 100 feet away from your work area at all times. Wood chips exit the chipper at great speeds. To be safe, do not operate the machine near small children or pets, and never allow children to operate the chipper. Stop the engine when another person or pet approaches.
- The flywheel will still rotate for a while after the engine is shut off. Shut down the engine, wait for all moving parts to come to a complete stop, remove spark plug wire, then wait 5 minutes before moving or working on the chipper.
- Never use the machine without ensuring that all guards and shields are in place, including the chipper hopper, discharge chute and blowback shield.
- Do not operate the engine with the air cleaner or the carburetor air intake cover removed. Removal of such parts could create a fire hazard. Do not use flammable solutions to clean the air filter.
- Always operate the machine from the operator zone (see “operation notes” in chapter 4). Never pass or stand on the discharge side of the machine when the engine is running or the flywheel is turning.
- Never try to pick up, move, or transport the machine while the engine is running or the flywheel is turning. Shut down the engine, wait for all moving parts to come to a complete stop (the flywheel will continue rotating for a while after the engine is shut down), disconnect spark plug wire, keeping it away from the spark plug to prevent accidental starting, then wait 5 minutes before moving.
- The muffler and engine become very hot and can cause a severe burn; do not touch.
- Clear the area of objects such as wire and rope, etc. Inserting these objects into the chipper hopper could damage the flywheel and/or cause injury.
- Never, under any conditions, remove, bend, cut, fit, weld, or otherwise alter standard parts on the DR 11.5 SELF-FEEDING CHIPPER. This includes all shields and guards. Modifications to your machine could cause personal injuries and property damage and will void your warranty.

## ***Safety for Children and Pets***

---

### **! WARNING**

Tragic accidents can occur if the operator is not alert to the presence of children and pets. Children are often attracted to the machine and the chipping activity. Never assume that children will remain where you last saw them. Always follow these precautions:

- Keep children and pets at least 100 feet from the working area and ensure they are under the watchful care of a responsible adult.
  - Be alert and turn the machine off if children or pets enter the work area.
  - Never allow children to operate the DR 11.5 SELF-FEEDING CHIPPER.
- 

## ***Safety with Gasoline - Powered Machines***

---

### **! WARNING**

Gasoline is a highly flammable liquid. Gasoline also gives off flammable vapor that can be easily ignited and cause a fire or explosion. Never overlook the hazards of gasoline. Always follow these precautions:

- Never run the engine in an enclosed area or without proper ventilation as the exhaust from the engine contains carbon monoxide, which is an odorless, tasteless, and deadly poisonous gas.
  - Store all fuel and oil in containers specifically designed and approved for this purpose and keep away from heat and open flame, and out of the reach of children.
  - Replace rubber fuel lines and grommets when worn or damaged and after 5 years of use.
  - Fill the gasoline tank outdoors with the engine off and allow the engine to cool completely. Don't handle gasoline if you or anyone nearby is smoking, or if you're near anything that could cause it to ignite or explode. Reinstall the fuel tank and fuel container caps securely.
  - If you spill gasoline, do not attempt to start the engine. Move the machine away from the area of the spill and avoid creating any source of ignition until the gas vapors have dissipated. Wipe up any spilled fuel to prevent a fire hazard and properly dispose of the waste.
  - Allow the engine to cool completely before storing in any enclosure. Never store the machine with gas in the tank or a fuel container near an open flame or spark such as a water heater, space heater, clothes dryer or furnace.
  - Never make adjustments or repairs with the engine running or flywheel turning. Shut down the engine, wait for all moving parts to come to a complete stop (the flywheel will continue rotating for a while after the engine is shut down), disconnect spark plug wire, keeping it away from the spark plug to prevent accidental starting, then wait 5 minutes before making adjustments or repairs.
  - Never tamper with the engine's governor setting. The governor controls the maximum safe operation speed and protects the engine. Over-speeding the engine is dangerous and will cause damage to the engine and to the other moving parts of the machine. If required, see your authorized dealer for engine governor adjustments.
-

## General Safety

### DANGER

Operating this chipper safely is necessary to prevent or minimize the risk of *DEATH OR SERIOUS INJURY*. Unsafe operation can create a number of hazards for you. Always take the following precautions when operating this chipper:

- Keep in mind that the operator or user is responsible for accidents or hazards occurring to other people, their property, and themselves.
- Your DR 11.5 SELF-FEEDING CHIPPER is a powerful tool, not a plaything. Exercise extreme caution at all times. The design of this machine is to chip wood. Do not use it for any other purpose.
- Know how to stop the chipper quickly; see “stopping the engine” in chapter 4.
- Operate this machine on a level surface only. Never operate your unit on a slippery, wet, muddy, or icy surface. Exercise caution to avoid slipping or falling.
- Keep your face and body back from the chipper hopper to avoid accidental bounce back of any material.
- When feeding material into the chipper hopper, be extremely careful that pieces of metal, rocks, or other foreign objects are not included. Personal injury or damage to the machine could result.
- Never allow an accumulation of processed material to build up in the discharge area as this will prevent proper discharge and can result in kickback from the chipper hopper.
- Whenever you leave the operating position or if you have to remove processed material, leaves, or debris from the machine, always shut down the engine, wait for all moving parts to come to a complete stop (the flywheel will continue rotating for a while after the engine is shut down), disconnect spark plug wire, keeping it away from the spark plug to prevent accidental starting, then wait 5 minutes before removing processed material, leaves, or debris from the machine.
- Always stop the engine when moving the DR 11.5 SELF-FEEDING CHIPPER.
- Keep combustible substances away from the engine when it is hot.
- Never cover the machine while the muffler is still hot.
- See manufacturer’s instructions for proper operation and installation of accessories. Only use accessories approved by DR power equipment.
- If the cutting mechanism strikes a foreign object or if your machine should start making an unusual noise or vibration, shut down the engine, wait for all moving parts to come to a complete stop (the flywheel will continue rotating for a while after the engine is shut down), disconnect spark plug wire, keeping it away from the spark plug to prevent accidental starting, then wait 5 minutes before inspecting for clogging or damage. Vibration is generally a warning of trouble. Clean and repair and/or replace damaged parts.
- Never tamper with safety devices. Check their proper operation regularly.
- Stay alert for hidden hazards or traffic. Never carry passengers on your machine.
- Never overload or attempt to chip material beyond the manufacturer’s recommendation; see “using the chipper hopper” in chapter 4. Personal injury or damage to the machine could result.
- While using the DR 11.5 SELF-FEEDING CHIPPER, don't hurry or take things for granted. When in doubt about the equipment or your surroundings, stop the machine and take the time to look things over.
- Never operate the machine when under the influence of alcohol, drugs, or medication.
- Use the machine only in daylight.
- Keep all nuts and bolts tight and keep the equipment in good operating condition.

## California Proposition 65

---

### **WARNING**

California Proposition 65:

- Engine exhaust and some of its constituents are known to the State of California to cause cancer, birth defects, and other reproductive harm.
  - This product contains or emits chemicals known to the State of California to cause cancer, birth defects, and other reproductive harm.
- 

### ***A Note to All Users***

Under California law, and the laws of some other states, you are not permitted to operate an internal combustion engine using hydrocarbon fuels without an engine spark arrester. This also applies to operation on US Forest Lands. All DR 11.5 SELF-FEEDING CHIPPERs shipped to California, New Mexico and Washington State are provided with spark arresters. Failure of the owner or operator to maintain this equipment in compliance with state regulations is a misdemeanor under California law and may be in violation of other state and/or federal regulations. Contact your local fire marshal or forest service for specific information in your area.

No list of warnings and cautions can be all-inclusive. If situations occur that are not covered by this manual, the operator must apply common sense and operate this DR 11.5 SELF-FEEDING CHIPPER in a safe manner. Contact us at [www.DRpower.com](http://www.DRpower.com) or call 1-800-DR-OWNER (376-9637) for assistance.





## Chapter 2: Setting Up the DR 11.5 SELF-FEEDING CHIPPER

This chapter outlines assembly and a few simple steps you will need to follow to set up your new machine before you use it. It may be helpful to familiarize yourself with the controls and features of your DR 11.5 SELF-FEEDING CHIPPER as shown in Figure 1 before beginning these procedures. If you have any questions at all, please feel free to contact us at [www.DRpower.com](http://www.DRpower.com) or call our Customer Service Representatives at our toll free number: 1-800-DR-OWNER (376-9637).

### DR 11.5 SELF-FEEDING CHIPPER Controls and Features

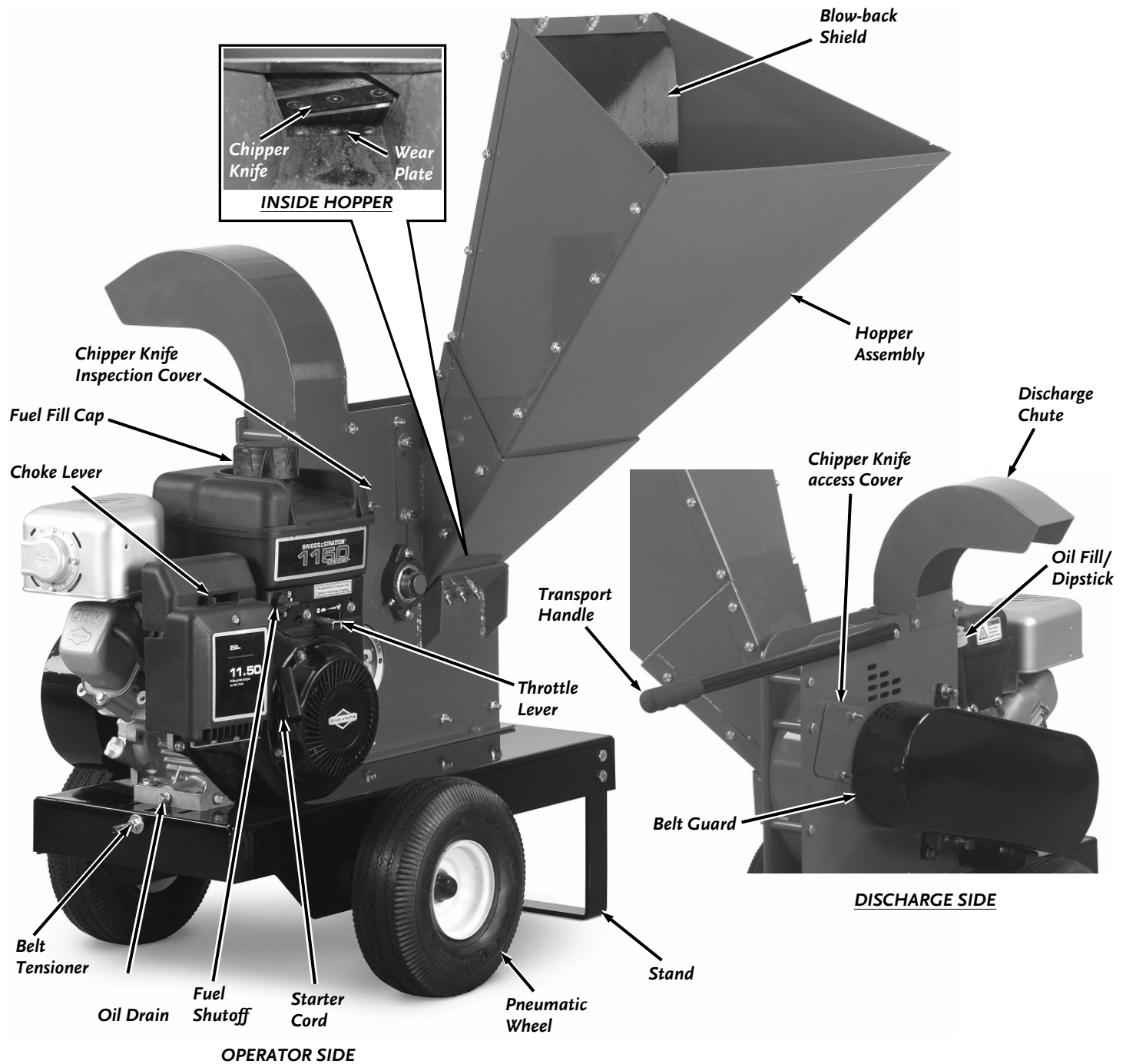

Figure 1

## Specifications

|                             |                                |
|-----------------------------|--------------------------------|
| Engine                      | Briggs & Stratton              |
| Ft-lbs Torque               | 11.50                          |
| Starting                    | Manual Recoil                  |
| Oil Capacity                | 20 oz.                         |
| Fuel Tank Capacity          | 3 Quarts                       |
| Chipping Capacity           | 3-3/4" Diameter                |
| Wheel Size                  | 4.10/3.50-4 Pneumatic w/ Tube  |
| Axle                        | 5/8" Diameter                  |
| Number of Chipper Knives    | 1                              |
| Chipper Knife Size          | 4-1/4" x 1-1/4 x 9/32"         |
| Chipper Knife Material      | Heat Treated Tool Steel        |
| Adjustable Knife Wear Plate | Yes                            |
| Chipper Flywheel            | 14" Dia. X 1/2" Thick          |
| Flywheel Weight             | 25 Lbs                         |
| Chipper Knife Tip Speed     | 101 mph                        |
| Hopper Material             | 10 GA Neck, 16 GA Hoppe, Steel |
| Frame Material              | 12 GA Steel                    |
| Hopper Opening at Top       | 23-1/2" x 15-3/4"              |
| Machine Weight              | 164 Lbs                        |

## Assembly Parts Identification

### Parts Supplied in Crate:

- DR 11.5 SELF-FEEDING CHIPPER
- Hopper Assembly
- Transport Handle
- Pin-Hitch Package (if ordered, see Chapter 6 "Chipper Accessories")

### Parts Supplied in Box (Figure 2):

- Discharge Chute
- Safety Glasses
- Safety & Operating Instructions Manual
- Engine Owner's Manual
- Hardware Bag (See next page for contents)



Figure 2

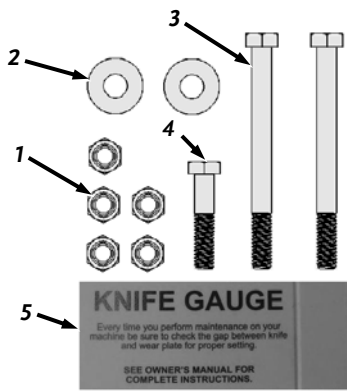

Figure 3

**Hardware Bag Parts (Figure 3):**

| Item # | Part # | Description                | Qty |
|--------|--------|----------------------------|-----|
| 1      | 14313  | Nut, Nylon Lock, 5/16-18   | 5   |
| 2      | 14515  | Washer, Flat, 5/16         | 2   |
| 3      | 14705  | Bolt, 5/16-18 x 3-1/2, Gr5 | 2   |
| 4      | 29260  | Bolt, 5/16-18 x 1-1/2, Gr5 | 1   |
| 5      | 16003  | Knife Gap Gauge            | 1   |

**Attaching the Hopper Assembly**

**Note:** We recommend that you have someone help you lift the Hopper in place and support it until it is secured to the Chipper.

**Tools Needed:**

- Two 1/2" Wrenches
1. Using 1/2" Wrenches, remove the two shipping nuts, but leave the Housing Bolts loosely in place (Figure 4).
  2. Lift the Hopper onto the Wear Plate Support and loosely attach a Washer and Locknut to each of the two Housing Studs (Figures 4 and 5).
  3. Thread the two Housing Bolts (with Lock Washers still in place) into the Hopper Weld Nuts (Figure 6).
  4. Fully tighten the hardware.

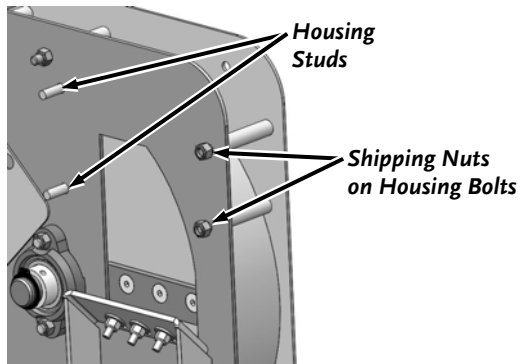

Figure 4

**Attaching the Discharge Chute and Transport Handle**

**Tools Needed:**

- Two 1/2" Wrenches
1. Position the Discharge Chute facing away from the Hopper Assembly as shown and secure with two 3-1/2" long Bolts and Locknuts using 1/2" Wrenches (Figure 7).
  2. To install the transport handle, first remove the 4-1/2" long Bolt and Locknut from the Housing. Position the Transport Handle as shown and loosely re-install the Bolt and Locknut.
  3. Install a 1-1/2" long Bolt and Locknut through the remaining Transport Handle hole.
  4. Fully tighten the Hardware.

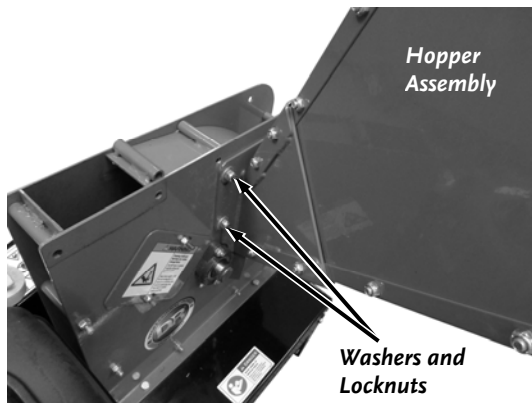

Figure 5

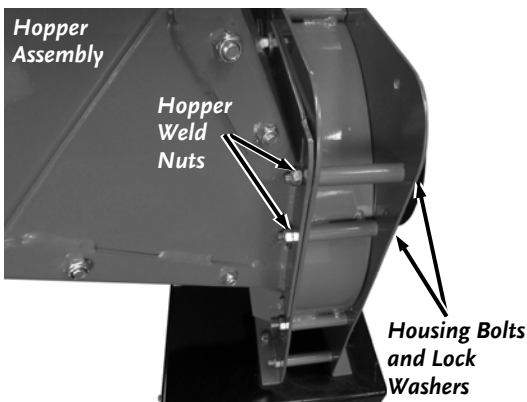

Figure 6

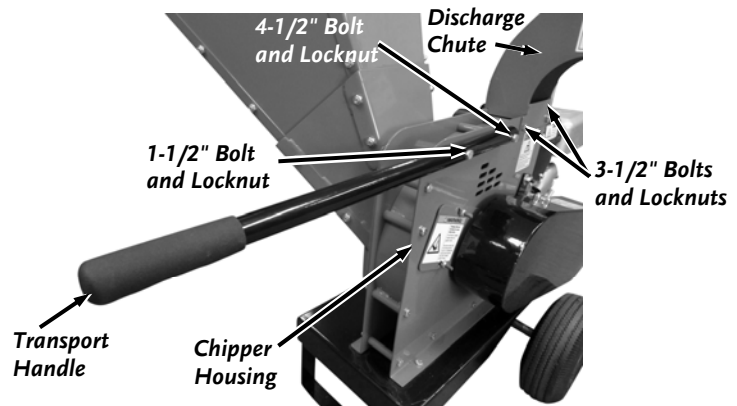

Figure 7

## Adding Engine Oil and Gasoline

| Capacities |                                         |
|------------|-----------------------------------------|
| Engine     | SAE 30 Oil - 20 oz. (0.59 L)            |
| Gas Tank   | Unleaded gasoline, 3 US quarts (3.79 L) |

**Tip:** To avoid confusion, we recommend leaving the caps on the gas and oil fills until you are ready to pour either gasoline or oil into the correct fill.

**Note:** Use SAE 30 high detergent oil classified "For Service SF, SG, SH, SJ" or higher. Do not use special additives. Other types of oil could cause problems operating your machine. Please refer to your Engine Owner's Manual for detailed oil information.

### NOTICE

- YOU MUST ADD OIL BEFORE STARTING THE ENGINE. This machine is shipped without oil. Traces of oil may be in the reservoir from factory testing, but you must add oil before starting the engine. Fill the reservoir slowly checking the dipstick frequently to avoid overfilling.
- To get an accurate reading when checking the oil level:
  - the machine should be on a level surface.
  - the dipstick should be pushed all the way down and turned a quarter turn clockwise to ensure an accurate oil level reading.

### Adding Oil

1. Place the machine on a level surface and remove the Dipstick (clean the end of the Dipstick with a rag) (**Figure 8**).
2. Machines are shipped with no oil. Add 1/2 of the SAE 30 high detergent oil recommended by the engine manufacturer and wait one minute for the oil to settle.
3. Replace the Dipstick all the way in and turn a quarter turn clockwise to lock it in place to ensure an accurate reading. Remove it to check the oil level (**Figure 9**).
4. If the oil level is low, continue adding a few ounces of oil at a time, rechecking the Dipstick until the oil reaches the fill mark. Be careful not to overfill.
5. Replace the Dipstick when finished.



Figure 8

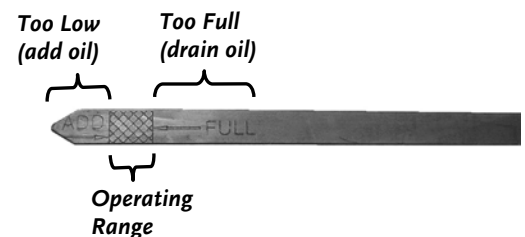

Figure 9

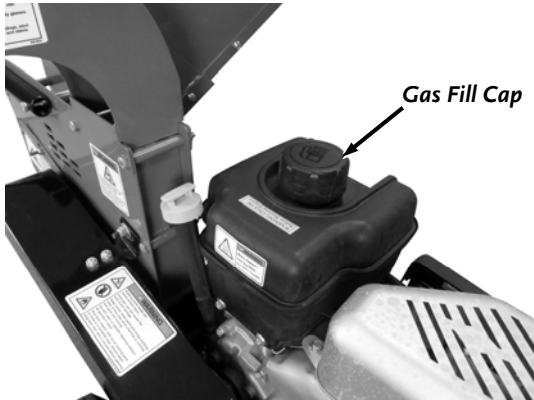

Figure 10

### **Adding Gas**

1. Remove the Gas Fill Cap and fill the Gas Tank with fresh, unleaded gas (with a minimum of 85 Octane) to approximately 1" to 1-1/2" below the top of the fill neck to allow for fuel expansion (**Figure 10**). Be careful not to overfill and reinstall the Gas Fill Cap before starting the engine. See your Engine Owner's Manual for more detailed information.

**Note:** To refill the gas tank, turn the engine OFF and let the engine cool at least two minutes before removing the gas fill cap.

### **Check the Tire Pressure**

#### **Tools Needed:**

- Tire Pressure Gauge
- Air Compressor

1. Remove the Valve Stem Protective Cap (**Figure 11**) and check the tire pressure with a Tire Pressure Gauge.
2. Compare the tire pressure reading from step 1 with the manufacturer's recommended tire pressure stamped on the side of the tire.
3. If the pressure is too low, add air through the Valve Stem with an air hose.

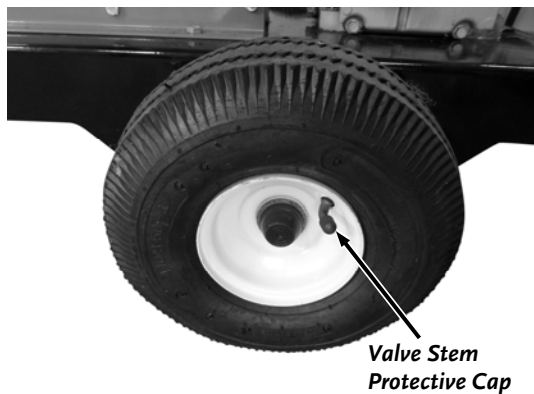

Figure 11

### **! WARNING**

Do not over inflate the tires. Inflate to the manufacturers recommended pressure found on the tires.

4. Replace the Valve Stem Protective Cap when finished.



## Chapter 3: Operating Your DR 11.5 SELF-FEEDING CHIPPER

### Before Starting the Engine

#### DANGER

- The design of this machine is for chipping wood. Never use this machine for any other purpose as it could cause serious injury.
- Contact with internal rotating parts will cause serious personal injury. Never put hands, face, feet, or clothing into chipper hopper or discharge opening or near the discharge area at any time.
- Before performing any maintenance procedure or inspection, shut down the engine, wait for all moving parts to come to a complete stop (the flywheel will continue rotating for a while after the engine is shut down), disconnect spark plug wire, keeping it away from the spark plug to prevent accidental starting, then wait 5 minutes before proceeding. Use only a wooden stick to clear jammed material.



Figure 12

1. Check the oil level every time you use the DR 11.5 SELF-FEEDING CHIPPER. Add oil if needed (see “Adding Engine Oil and Gasoline” in Chapter 3).
2. Check the gas level. Add gas as needed (see “Adding Engine Oil and Gasoline” in Chapter 3).
3. Ensure that the Fuel Shut-Off Valve is in the “ON” position (**Figure 12**).
4. Remove any debris buildup from the machine before every use of the Chipper.

**Note:** Check and re-tighten the Drive Belt, if necessary, after an initial break-in period of one (1) hour (see Chapter 5 “Maintaining the DR 11.5 SELF-FEEDING CHIPPER”).

### Operation Notes

- Visually check the Chipper Knife for damage before each use of the machine. See “Visual Inspection of the Chipper Knife (before each use)” in Chapter 5 for info on accessing the Chipper Knife (by removing only the Front Knife Access Cover).
- At engine start-up, the engine of your DR CHIPPER operates under no load until approximately 1800 RPM, at which speed the Centrifugal Clutch engages and begins driving the Rotor Assembly. Always operate the Engine at full speed when chipping.
- Only operate the DR 11.5 SELF-FEEDING CHIPPER from the Operator Zones (**Figure 13**).
- Keep proper balance and footing while operating the DR 11.5 SELF-FEEDING CHIPPER.
- ALWAYS stop the engine when leaving the Operating Zones or when moving the machine.
- Never move the Chipper while the engine is running or the Flywheel is turning.

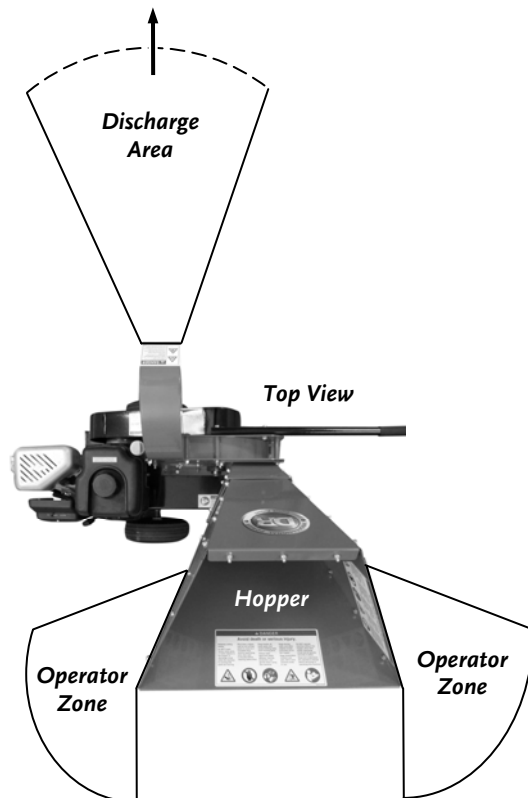

Figure 13



## Processing Material

---

### **WARNING**

- Always wear protective goggles or safety glasses with side shields while chipping to protect your eyes from possible thrown debris.
  - Avoid wearing loose clothing or jewelry, which might catch on moving parts or the material fed into the chipper hopper.
  - We recommend wearing gloves while chipping. Be sure your gloves fit properly and do not have loose cuffs or drawstrings.
  - Wear shoes with non-slip treads when using your chipper. If you have safety shoes, we recommend wearing them. Do not use the machine while barefoot or wearing open sandals.
  - Wear long pants while operating the DR 11.5 SELF-FEEDING CHIPPER.
  - Use ear protectors or ear plugs rated for at least 20 dba to protect your hearing.
- 

### **WARNING**

The chipper hopper must be securely bolted to your DR 11.5 SELF-FEEDING CHIPPER and the blowback shield in place before using the machine!

---

### **NOTICE**

- Use common sense when using the machine. Learn to recognize the change in sounds when overloaded. Turn off the engine immediately if the machine becomes jammed to prevent damage to the drive system.
  - Never throw remaining stubs or knots into the chipper hopper; damage will result.
- 

The Chipper is designed to accept wood only. The Chipper Knife mounted on a revolving flywheel turns branches fed into the Chipper Hopper into “chips”. The Chipper can chip branches ranging in size up to 3-3/4" in diameter. Cut your branches into manageable lengths before feeding them into the Chipper Hopper.

- Your DR 11.5 SELF-FEEDING CHIPPER can process dry or green wood up to 3-3/4" in diameter.
- The Chipper will self-feed the wood once it contacts the knife edge so forcing the branches into the Hopper is not necessary if the knife is sharp.
- Green wood will process quicker and easier than dry wood.
- Softwood processes easier than hardwood.
- Your operator experience will teach you how different types of wood will chip and how fast you can process them.
- When chipping branches, sometimes a tail will develop at the end of a branch. To avoid this, rotate the branch while feeding it into the Chipper Hopper.
- Rotating the branch as you feed it into the machine will improve chipping performance.
- Use caution with small diameter green saplings and branches less than 2" in diameter. Chip these grouped or bundled together to provide support for each other. If the material is 2" or larger, feed only one at a time into the Chipper Hopper.
- Make sure the DR 11.5 SELF-FEEDING CHIPPER finishes processing material in the Hopper before shutting the engine off.
- Do not force material into the Chipper. If the machine does not chip well, the Chipper Knife may need sharpening or replacement, or the gap between the Knife and the Wear Plate needs adjusting. See “Removing, Replacing and Adjusting the Chipper Knife and Wear Plate” in Chapter 5.
- Extremely hard knots will not process very well. Push any short stubs that have not self-fed through the Chipper, with the next branch to be chipped.
- Cut the material to be chipped into manageable lengths of no more than five or six feet long before chipping them.
- Overloading the Chipper Hopper will cause the rotor speed to decrease. If you hear the engine RPM decreasing, stop feeding material into the Chipper Hopper until the engine has returned to full speed.



Figure 14

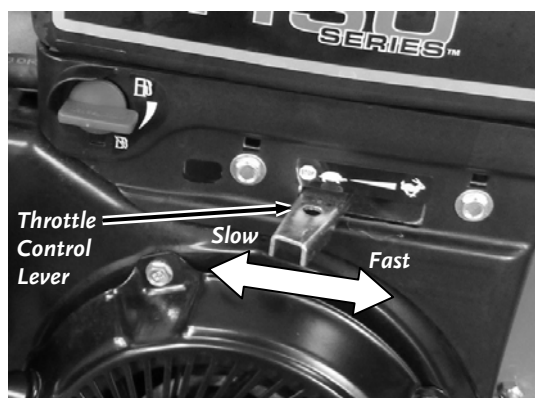

Figure 15



Figure 16

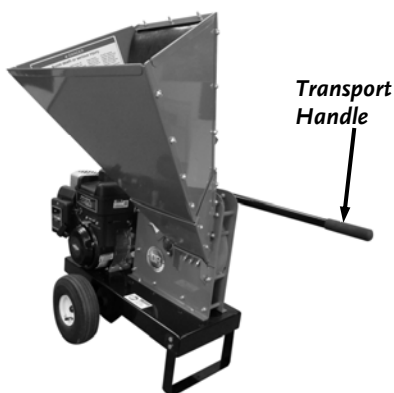

Figure 17

## Starting the Engine

1. Ensure that the Fuel Shut-Off Valve is in the "ON" position (**Figure 12**).
2. Move the Choke Control Lever to the "CHOKE" position if the engine is cold (**Figure 14**). Leave it in the RUN position if the engine is already warm.
3. Move the Throttle Control Lever to about half way between Slow and Fast position (**Figure 15**).
4. Slowly pull the Starter Cord until you feel resistance, then pull quickly (**Figure 16**). The Cord will recoil back into position.
5. As the engine warms up, slowly adjust the Choke to the "Run" position (**Figure 14**). Wait until the engine runs smoothly before each Choke adjustment.
6. When the Engine is warmed up and running smoothly with the Choke in the "RUN" position, move the Throttle Control Lever to the fast position (rabbit icon) for chipping (**Figure 15**).

## Stopping the Engine

### ! WARNING

The flywheel will still rotate for A WHILE after the engine is shut off. shut down the engine, wait for all moving parts to come to a complete stop, remove spark plug wire, then wait 5 minutes before moving or working on the chipper.

### NOTICE

Never stop the engine by moving the choke lever to the choke position. This could cause an engine backfire resulting in engine damage.

1. Slowly move the Throttle Control Lever all the way to the "STOP" position (**Figure 15**).

**Note:** Close the Fuel Shut-Off Valve when transporting or storing the machine.

## Moving the DR 11.5 SELF-FEEDING CHIPPER

The DR 11.5 SELF-FEEDING CHIPPER can be easily moved using the Transport Handle. The Chipper can also be moved by a tractor with the Pin-Hitch Package installed (see Chapter 7, "Chipper Accessories").

### ! WARNING

Never try to pick up, move, or transport the machine while the engine is running or the flywheel is turning. Shut down the engine, wait for all moving parts to come to a complete stop (the flywheel will continue rotating for a while after the engine is shut down), disconnect spark plug wire, keeping it away from the spark plug to prevent accidental starting, then wait 5 minutes before moving.

1. Grasp the Transport Handle and lift the Front Stand off the ground (**Figure 17**).
2. Move the Chipper to the desired location.

## To Free a Jammed Flywheel

### **⚠ WARNING**

The flywheel will still rotate for A WHILE after the engine is shut off. Shut down the engine, wait for all moving parts to come to a complete stop, remove spark plug wire, then wait 5 minutes before moving or working on the chipper.

#### **Tool Needed:**

- Two 1/2" Wrenches

#### **Disassemble:**

1. Remove any material left in the Chipper Hopper.
2. Remove the Bolts and Locknuts from the Discharge Chute using 1/2" Wrenches (**Figure 18**).
3. Remove the Discharge Chute from the Chipper Housing.
4. Check to see if the Discharge Chute or Discharge opening is clogged. If it is, clear it with a branch.

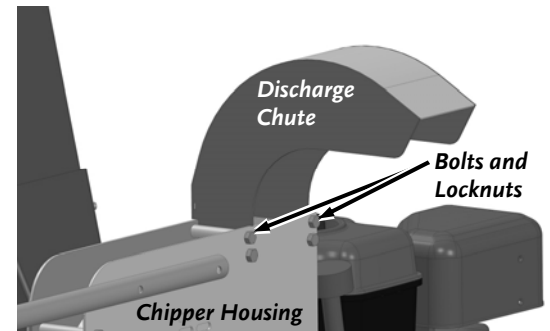

**Figure 18**

### **NOTICE**

Never pry against the Chipper Housing when removing the discharge chute, or at any other time. This will cause damage to the machine.

5. With a wooden stick, loosen and remove any material left in the Chipping Chamber and make sure the Flywheel turns freely with the stick.

#### **Reassemble:**

1. Position the Discharge Chute onto the Chipper Housing and secure with two Bolts and Locknuts using 1/2" wrenches (**Figure 18**).
2. Reconnect the spark plug wire and start the Chipper engine; allowing the remaining material in the Chipping Chamber to discharge.
3. If the Chipping Chamber doesn't clear and the flywheel is still jammed, repeat above process.

**Note:** Be certain the Chipping Chamber is clear before trying to process more material into the Chipper Hopper.

## Chapter 4: Maintaining The DR 11.5 SELF-FEEDING CHIPPER

This chapter covers regular maintenance procedures that will ensure the best performance and long life of your DR 11.5 SELF-FEEDING CHIPPER. For engine maintenance, please refer to the Engine Owner's Manual that came with your machine. Service intervals listed in the checklist below supersede those listed in the Engine Owner's Manual.

Maintenance Kits and Accessories are available through our website at [www.DRpower.com](http://www.DRpower.com).

### **WARNING**

The Flywheel will still rotate for A WHILE after the engine is shut off. Shut down the engine, wait for all moving parts to come to a complete stop, remove spark plug wire, then wait 5 minutes before performing maintenance on the chipper.

### **Regular Maintenance Check List**

**Note:** Consider that the service intervals shown are the maximum under normal operating conditions. Increase frequencies under extremely dirty or dusty conditions.

| Procedure                                                     | Before Each Use              | Every 25 Hours | Every 40 Hours |
|---------------------------------------------------------------|------------------------------|----------------|----------------|
| Check Engine Oil Level                                        | ▲                            |                |                |
| Check General Equipment Condition                             | ▲                            |                |                |
| Check that the Flywheel turns freely (with a long stick only) | ▲                            |                |                |
| Visually inspect Knife for damage and sharpness               | ▲                            |                |                |
| Clean Engine Exterior and Cooling Fins                        | ▲                            |                |                |
| Inspect or replace Air Filter                                 | ▲                            |                |                |
| Check the Tire Pressure                                       | ▲                            |                |                |
| Change Engine Oil                                             | 1 <sup>st</sup> time 5 hours | ▲              |                |
| Check Belt Tension and Condition                              | 1 <sup>st</sup> time 1 hour  | ▲              |                |
| Check Knife and Wear Plate for Sharpness                      |                              | ▲              |                |
| Inspect or replace Drive Belt                                 |                              | ▲              |                |
| Inspect or replace Spark Plug                                 |                              | ▲              |                |
| Check Knife to Wear Plate Gap                                 |                              | ▲              |                |
| Check Knife and Wear Plate Attachment Screws                  |                              |                | ▲              |
| Check Flywheel Bearing Collar Set Screws                      |                              |                | ▲              |
| Lubricate Flywheel Bearings                                   |                              |                | ▲              |

### **Grease Fittings**

### **WARNING**

The flywheel will still rotate for A WHILE after the engine is shut off. Shut down the engine, wait for all moving parts to come to a complete stop, remove spark plug wire, then wait 5 minutes before moving or working on the chipper.

Your DR 11.5 SELF-FEEDING CHIPPER was greased at the Factory. The operator needs to periodically lubricate the two Bearings of the Chipper Assembly.

### Tools and Supplies needed:

- Flexible hose grease gun
- Lithium grease
- Clean cloth
- 1/8" Allen Wrench
- Loctite® 243 (if needed)

1. To gain access to the rear Chipper Bearing you must remove the Belt Cover (see "Removing, Replacing and Adjusting the Drive Belt" in this Chapter).
2. Wipe all dirt, etc., from the grease fittings with a clean cloth (**Figure 19**).
3. Apply no more than three pumps of quality general-purpose lithium grease with a hand-pumped grease gun to each Bearing Grease Fitting, one on either side of the Chipper Assembly.

### NOTICE

Over lubrication can damage the bearings.

4. Check the Set Screws for tightness. If they are not tight then remove them with a 1/8" Allen wrench, apply Loctite® to the threads, then reinstall and tighten the Set Screws.
5. Replace the Belt Guard.

### Removing and Replacing the Engine Oil

#### ! WARNING

The flywheel will still rotate for A WHILE after the engine is shut off. Shut down the engine, wait for all moving parts to come to a complete stop, remove spark plug wire, then wait 5 minutes before moving or working on the chipper.

### Tools and Supplies Needed

- SAE 30 HD Oil
- 3/8" Wrench
- Suitable container for used oil
- Rags

**Note:** Drain the oil when the engine is warm. Warm oil drains quicker and more completely.

1. Position a suitable oil receptacle under the machine below the engine oil Drain Plug (**Figure 20**) and remove the engine oil Dipstick (**Figure 21**).
2. Remove the Oil Drain Plug Engine with a 3/8" wrench (**Figure 21**). Allow the used oil to drain completely, and then replace the Oil Drain Plug.
3. Replace the engine oil using SAE 30 HD oil (see "Adding Engine Oil and Gasoline" in Chapter 3).
4. Reattach the spark plug wire.

**Note:** Be sure to use environmentally safe disposal procedures in the disposing of the used oil.

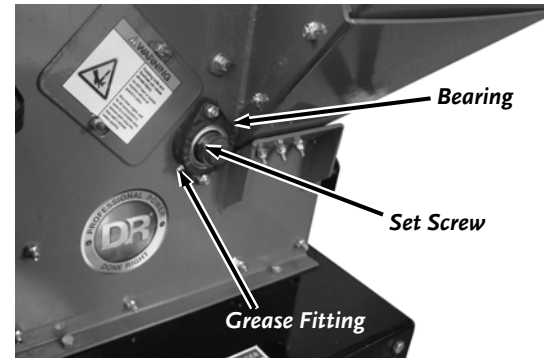

Front Chipper Bearing Shown  
**Figure 19**

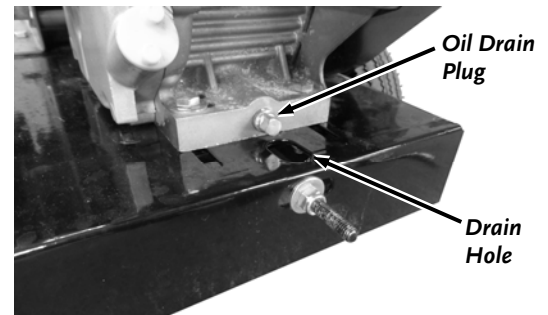

**Figure 20**



**Figure 21**

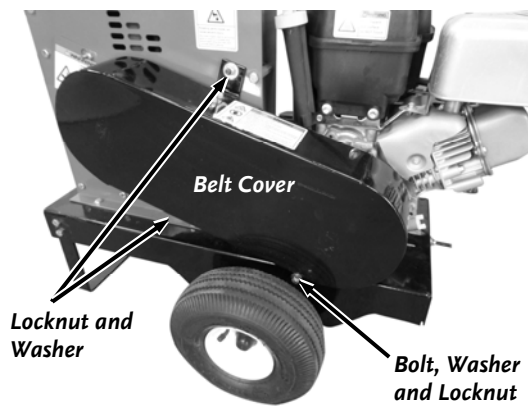

Figure 22

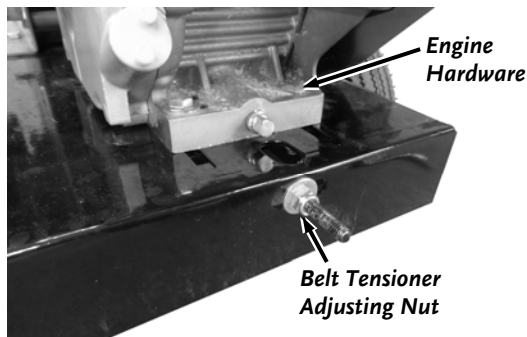

Figure 23

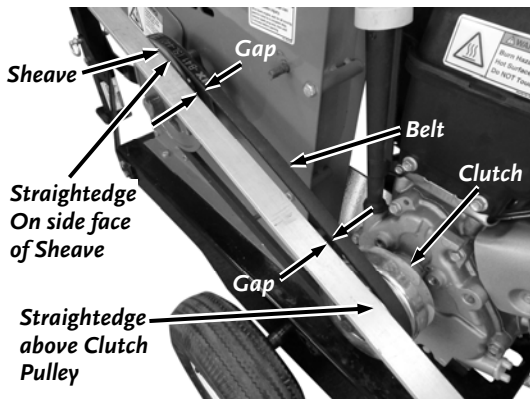

Figure 24

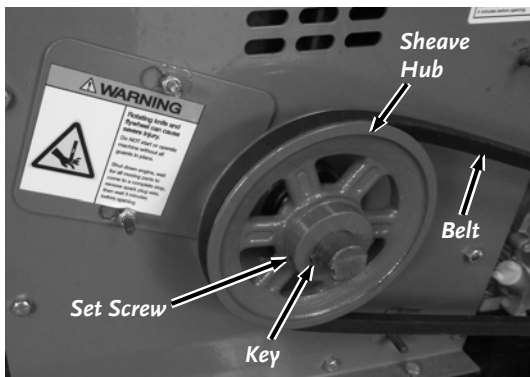

Figure 25

## Removing, Replacing and Adjusting the Drive Belt

### **! WARNING**

The flywheel will still rotate for A WHILE after the engine is shut off. shut down the engine, wait for all moving parts to come to a complete stop, remove spark plug wire, then wait 5 minutes before moving or working on the chipper.

### **NOTICE**

Use only DR belts on your machine. The belts have been thoroughly tested and proven for many hours of use.

#### Tools Needed:

- Tape Measure
- Two 1/2" Wrenches
- 1/8" Allen Wrench (if necessary)
- Straightedge

#### Removing the Belt

1. Remove the Bolt, Washer and Locknut from the lower rear Belt Guard mounting using 1/2" Wrenches (**Figure 22**).
2. Remove the two Locknuts and Washers from other two Belt Guard mounting areas using a 1/2" Wrench.
3. Remove the Belt Guard.
4. Loosen the four Engine Bolts (two on the left side and two on the right side) using 1/2" Wrenches (**Figure 23**).
5. Using a 1/2" Wrench, loosen the Adjusting Nut on the Belt Tensioner to create about a 1/2" gap, then slide the Engine in until the belt is loose enough to remove.
6. Remove the Belt from the Clutch and Sheave (**Figure 24**).

#### Installing and Adjusting the Belt

**Note:** The Belt Tensioner Adjusting Nut may need to be loosened up more per the previous instructions, "Removing the Belt", to enable you to install a new Belt.

1. Install the Belt onto the Sheave and Clutch.
2. Tighten the Adjusting Nut on the Belt Tensioner using a 1/2" Wrench to take up the slack in the Belt, but not too tight at this point (**Figure 23**).
3. Check the alignment of the Clutch with the Sheave by placing a Straightedge against the Sheave outside face near, but not touching, the Clutch Pulley (**Figure 24**).
4. Check the gap from the Straightedge to the Belt near the Sheave and near the Clutch. If the gap is the same then no adjustment is needed. If the gap is not the same then adjustment is necessary, correct the alignment as follows:
  - a) Loosen the Sheave Hub Set Screws with a 1/8" Allen Wrench (**Figure 25**).

- b) Using the Straightedge, align the Clutch and Sheave by moving the Sheave in or out on the Rotor Shaft. **Do not make the adjustment by attempting to move the Clutch on the Engine Shaft.**
  - c) Recheck the alignment and then retighten the Sheave Hub Set Screws.
5. Tighten the Engine Bolts (**Figure 23**)
  6. Place a Straightedge on the Belt (over the Clutch and Sheave) and push down on the Belt to measure the deflection from the Straightedge to the Belt with a tape measure (**Figure 26**).

**Note:** The force when pushing down on the Belt should be approximately 3 pounds.

7. The measurement should be approximately 3/8".
8. If the measurement is not correct, loosen the Engine Bolts and tighten or loosen the Adjusting Nut as needed (**Figure 23**).
9. Repeat steps 5 through 8 until the proper Belt tension is achieved.
10. When the Belt is properly tensioned, double check that the four Engine Bolts are completely tightened.
11. Reinstall the Belt Guard.

**Note:** Check the Drive Belt after an initial break-in period of one (1) hour and adjust if necessary.

### Removing, Replacing and Adjusting the Chipper Knife and Wear Plate

#### **! WARNING**

The flywheel will still rotate for A WHILE after the engine is shut off. Shut down the engine, wait for all moving parts to come to a complete stop, remove spark plug wire, then wait 5 minutes before moving or working on the chipper.

#### **NOTICE**

- Routinely check the chipper knife for sharpness. Using a dull knife will decrease performance and cause excessive vibration that will cause damage to the DR 11.5 SELF-FEEDING CHIPPER.
- Routinely check the wear plate for a sharp square edge. Using a rounded or chipped wear plate will decrease performance and cause excessive vibration that will cause damage to the DR 11.5 SELF-FEEDING CHIPPER.

### Inspecting the Chipper Knife and Wear Plate

Routine inspection of the Chipper Knife and Wear Plate will ensure that your DR 11.5 SELF-FEEDING CHIPPER is operating at full efficiency (see "Regular Maintenance Checklist" at the beginning of this Chapter). Operating with a worn or damaged Chipper Knife or Wear Plate will cause extreme stress and vibration to the machine and make chipping difficult for the operator.

The Knife should be visually checked for damage before each use. The first procedure ("Routine visual inspection of the Chipper Knife") describes a quick way to check the Knife only through the Access Cover. The second procedure ("Inspecting the Chipper Knife and Wear Plate") is for a more detailed look at the condition of the Knife and Wear Plate by removing the Hopper.

#### VISUAL INSPECTION OF THE CHIPPER KNIFE (before each use)

##### Tools Needed:

- 7/16" Wrench
1. Loosen the Locknuts that secure the Front Access Cover with a 7/16" wrench then slide the Cover over and lift it over the Locknuts (**Figure 27**).
  2. Rotate the Flywheel with a long stick until the Knife is visible.

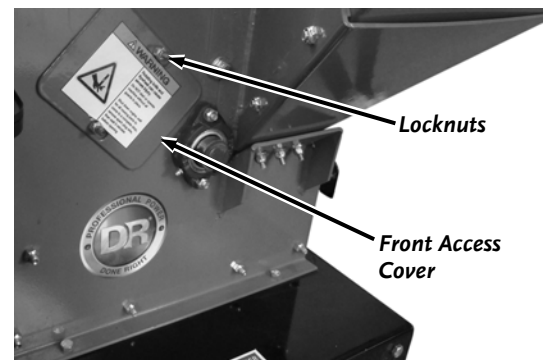

**Figure 27**

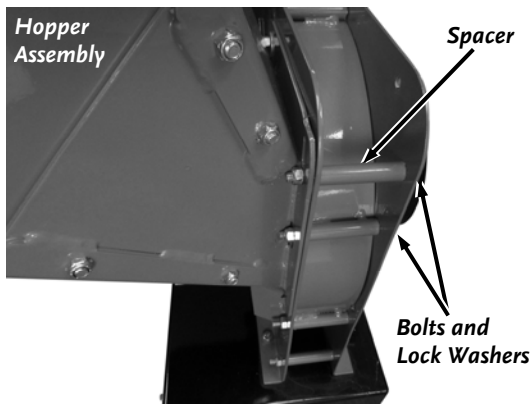

Figure 28

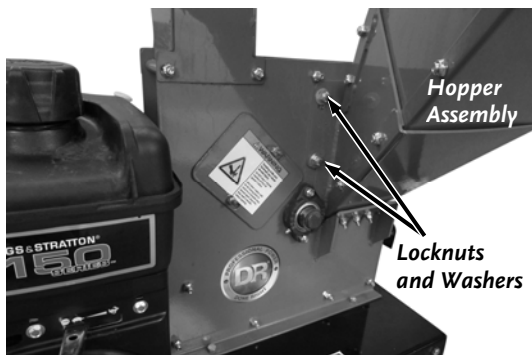

Figure 29

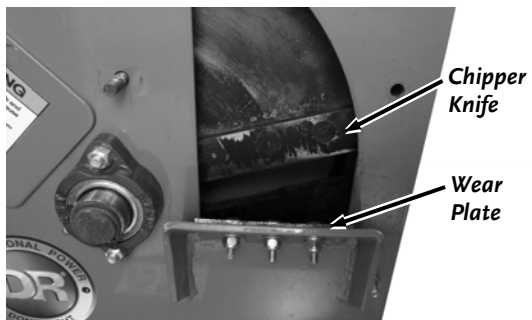

Figure 30

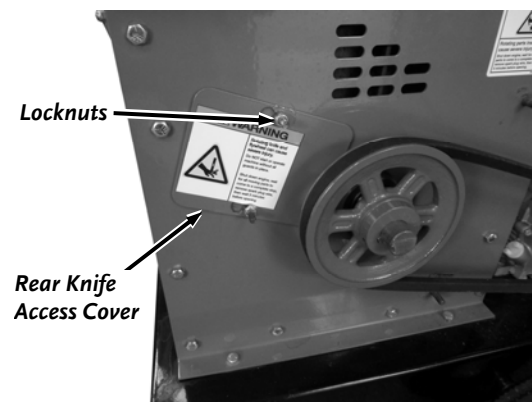

Figure 31

3. If the Knife has visible nicks or damage it must be sharpened or replaced (see “Removing and Replacing the Chipper Knife” in this chapter).
4. If the Knife does not appear to have any damage, replace the Access Cover and secure with nuts using a 7/16" wrench.

### INSPECTING THE CHIPPER KNIFE AND WEAR PLATE

#### **! CAUTION**

The hopper should be supported when the mounting hardware is removed. Removal of the hopper is difficult for one person. Two people are needed for the hopper removal process.

#### Tools Needed:

- 1/2" Wrench
1. Using a 1/2" Wrench, loosen the two rear Bolts so they are not threaded into the Hopper Assembly. The Bolts, Lock Washers, and Spacer may remain loosely in place (**Figure 28**).
  2. Remove the two Locknuts and Washers at the front side of the Hopper (**Figure 29**).
  3. Remove the Hopper Assembly.
  4. Use a long stick to rotate the Flywheel until the Knife is next to the Wear Plate (**Figure 30**).
  5. Closely inspect the Chipper Knife and Wear Plate for nicks or dull (rounded) edges.
  6. If necessary, sharpen or replace the Chipper Knife and/or Wear Plate per the procedures in the next section.
  7. Reinstall the Hopper Assembly when finished.

### Removing and Replacing the Chipper Knife

#### Tools and Supplies Needed:

- 7/16" Wrench
- 3/16" Allen wrench
- Ratchet with 1/2" Socket
- Awl or Sharp Tool
- Gloves

#### **! WARNING**

Be careful and wear gloves when working near the chipper knife. The knife edge can cut you if you come in contact with it.

1. Remove the Hopper Assembly as described in the previous section “INSPECTING THE CHIPPER KNIFE AND WEAR PLATE”.
2. Remove the Belt Guard (see “Removing and Replacing the Drive Belt” in this Chapter to remove the Belt Guard).
3. Loosen the Locknuts that secure the rear Access Cover with a 7/16" wrench then slide the Cover over and lift it over the Locknuts (**Figure 31**).



4. Rotate the Flywheel using a long stick until the three countersunk Allen Screws and Lock Nuts attaching the Knife to the Flywheel are visible through the Access Cover and Hopper openings (**Figure 32 and 33**).
5. Clean out the heads of the Allen Screws with an Awl or Sharp Tool.
6. Insert a 3/16" Allen Wrench into the head of a screw.
7. While holding the Allen Wrench, remove the Lock Nut using a 1/2" socket. Be careful not to drop the Lock Nut into the Chipper.
8. Repeat Steps 6 and 7 for the remaining two Allen Screws.
9. Remove the dull or damaged Knife and clean any debris out of the Flywheel Slot and Knife mounting so the replacement Knife will be able to mount flush against the Flywheel.

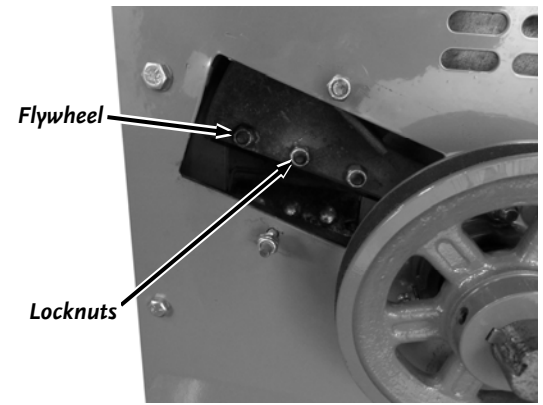
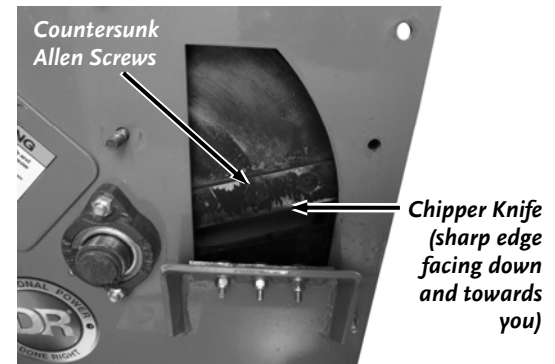

**Figure 32**

## **! CAUTION**

If the flywheel surface is not cleaned properly and the chipper knife is not mounted flush on the flywheel, the knife could crack when the hardware is tightened.

10. Install a new or sharpened Knife as shown (**Figure 33**) with the Knife edge facing down and towards you and finger tighten the Allen screws and Lock Nuts (use the new hardware supplied with a new Knife kit) to hold the Knife to the Flywheel.
11. Using a 3/16" Allen wrench and a 1/2" socket, tighten the center Screw and Locknut, then tighten the outer Screw and Locknut, and finally tighten the inner Screw and Locknut.
12. Double-check that all three Locknuts on the Allen Screws are tight.
13. Reinstall the Access Cover and Hopper Assembly.
14. Replace the Belt Guard.
15. Check the gap between the Knife and Wear Plate and adjust if needed (See "Checking and Adjusting the Knife to Wear Plate Gap" on the next page).



**Figure 33**

### **Removing and Replacing the Wear Plate**

#### **Tools Needed:**

- 7/16" wrench
1. Remove the Hopper Assembly (See "Inspecting the Chipper Knife and Wear Plate" in this Chapter).
  2. Remove the three Locknuts and Carriage Bolts that attach the Wear Plate to the Housing using a 7/16" Wrench and remove the Wear Plate (**Figure 34**).
  3. Install the new Wear Plate and secure with the Carriage Bolts and Locknuts.

**Note:** The Gap between the Knife and Wear Plate must be adjusted whenever the Wear Plate is removed. See the following instructions.

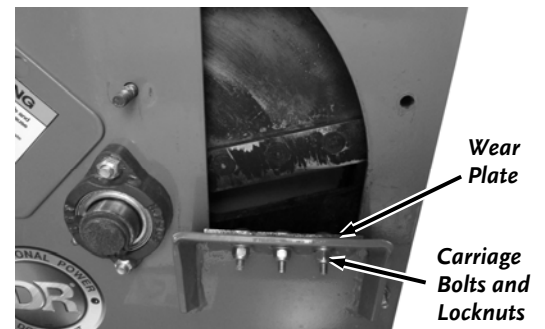

**Figure 34**

## Checking and Adjusting the Knife to Wear Plate Gap

When you replace the Knife, you must check and set the clearance between the Knife and Wear Plate. Set this clearance or gap to 1/16" by using the Gap Tool that is supplied with the Chipper and with a new Knife Kit. If the gap between the Wear Plate and the Knife is not set correctly, you will have excessive vibration when chipping and the Knife will seem to be dull. The Wear Plate should have a square edge and be free of dents or gouges. The Wear Plate can be hand sharpened (see steps below). Be careful not to overheat it during the sharpening process. This will change the characteristics of the steel and you will then have to replace the Wear Plate (see "Wear Plate Sharpening" in this chapter).

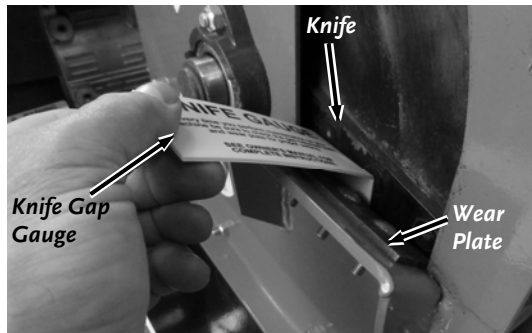

Figure 35

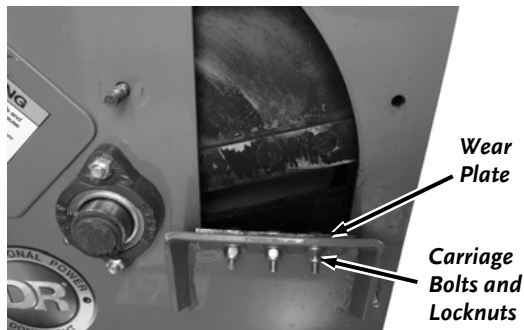

Figure 36

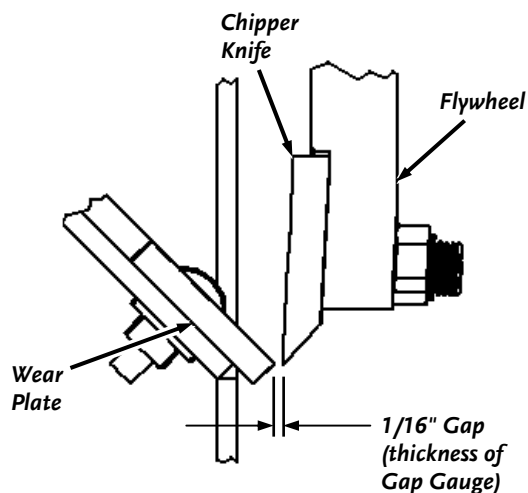

Figure 37

### Tools Needed:

- Gap Gauge (provided with Chipper)
  - 7/16" Wrench
1. Remove the Hopper Assembly (See "Inspecting the Chipper Knife and Wear Plate" in this Chapter).
  2. Use a stick to rotate the Flywheel until the Knife is positioned next to the Wear Plate.
  3. Slide the Knife Gap Gauge in between the Knife and Wear Plate to check the clearance (**Figure 35**).
    - If the Knife Gauge slides freely, with no resistance and a lot of extra space, the Wear plate must be adjusted. Proceed to step 4.
    - If the Knife Gauge will not slide down between the Knife and Wear Plate, the Wear Plate must be adjusted. Proceed to step 4.
    - If the Knife Gauge slides in between the Knife and Wear Plate with some resistance felt against them both or slides in between with no noticeable space, then the Wear plate is properly adjusted. Skip to step 7.
  4. To adjust the Wear Plate Gap, loosen the three Nuts on the Carriage Bolts with a 7/16" wrench just enough so the Wear Plate will move but still have a slight resistance. Now you can slide the Wear Plate up or down (in or out) to achieve the correct gap setting (**Figure 36 and 37**).
  5. Slide the Gap Gauge between the Knife and Wear Plate (**Figure 35**). Adjust the Wear Plate against the Knife Gauge and tighten the outside Locknut, check the gap, tighten the inside Locknut and then the center Locknut.
  6. Check the adjustment as described in the "Checking the Knife to Wear Plate Gap" in the previous section.
  7. Reinstall the Hopper Assembly

## NOTICE

After any knife or wear plate maintenance or adjustment, rotate the chipper flywheel by using a wooden stick and watch and listen carefully for any unusual noises, clicking or vibration. If you detect any of these, inspect the machine for damage, or any loose parts. Repair or replace any damaged parts and tighten any loose parts before starting the DR 11.5 SELF-FEEDING CHIPPER.

## Chipper Knife Sharpening

- You should never attempt to sharpen the Chipper Knife freehand.
- It is extremely important to consistently maintain the 45-degree angle for proper performance (**Figure 38**).
- Excessive heat generated during the sharpening process will damage Knives and weaken the metal. Be sure not to overheat the Knife during sharpening because it will shorten the life of the Knife.
- Take the Chipper Knife to a machine shop for proper sharpening.
- How many times a Knife can be sharpened is determined by how much material needs to be taken off to sharpen or to compensate for dents or gouges.
- A new Chipper Knife has 1.442" measurement between the short side bevel edge and the Knife Top Edge (**Figure 39 "New Knife"**).
- The knife should never be sharpened to the extent that more than 3/32" is taken off this measurement.
- Once this measurement is below 1.348" (see **Figure 39 "Sharpened Knife"**), or if you are unable to remove dents or gouges with these guidelines, replace the Knife.

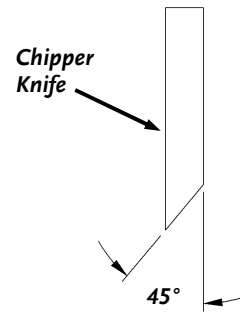

Figure 38

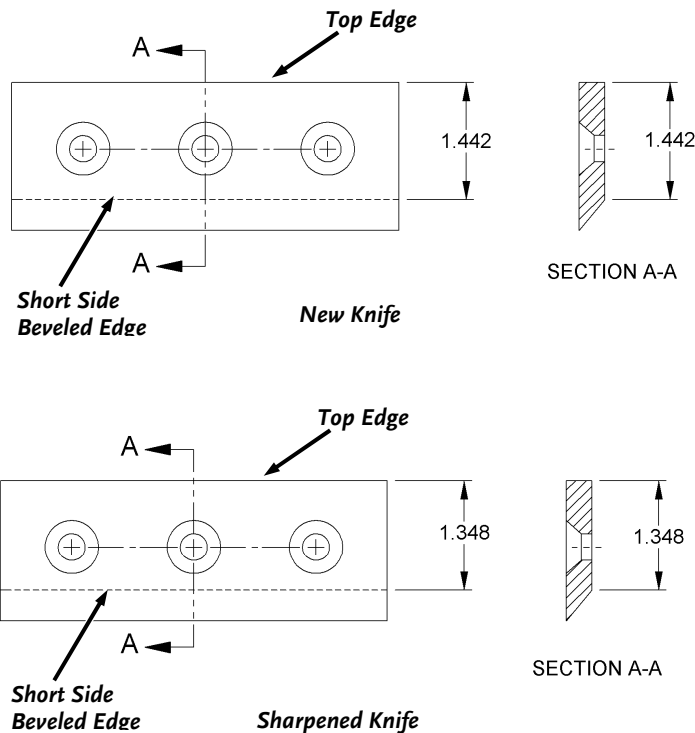

Figure 39

## Wear Plate Sharpening

The Wear Plate edges can become rounded and chipped during use and must be squared off to ensure efficient operation.

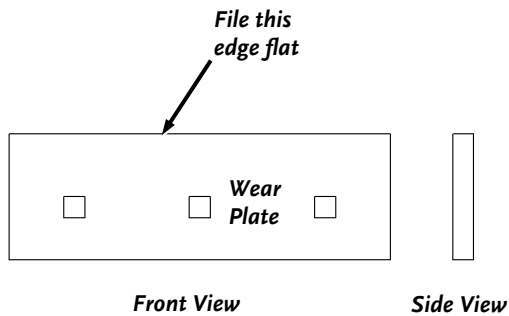

Figure 40

### Tools Needed:

- Flat File
- Straightedge

1. Secure the Wear Plate in a vise.
2. File the edge of the Wear Plate to take out any nicks and to square rounded edges (**Figure 40**).
3. Check with a Straightedge to ensure that the Wear Plate edge is flat and straight.

**Note:** If the Wear Plate is filed enough times that the proper gap between the Knife and Wear Plate cannot be set with the Gap Gauge, you will need to replace the Wear Plate.

## Removing and Replacing the Wheels

### WARNING

The flywheel will still rotate for A WHILE after the engine is shut off. Shut down the engine, wait for all moving parts to come to a complete stop, remove spark plug wire, then wait 5 minutes before moving or working on the chipper.

The Wheels on the DR 11.5 SELF-FEEDING CHIPPER are pneumatic and have pressed in Bearings for easy transport. With use, tires or Bearings may need replacing. The following procedures will explain the replacement procedures.

### Tools and Parts Needed:

- Large Flat Head Screwdriver
- Cutting Pliers
- Fine Tooth File
- Soft Faced Hammer
- Push Nut w/Cap

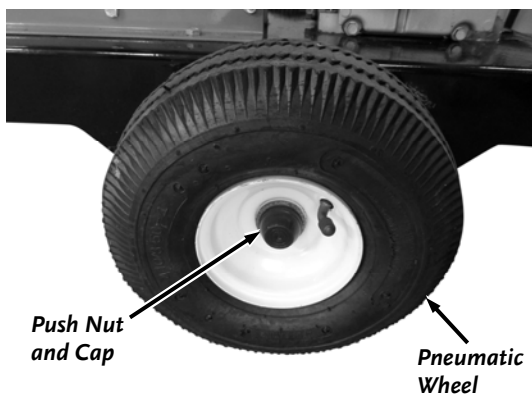

Figure 41

1. Jack up the side of the Chipper just until the Pneumatic Wheel is off the ground.
2. Pry the Cap off the axle with a Flat Head Screwdriver (**Figure 41**).
3. Bend the Push Nut out with the Flat Head Screwdriver and cut it with Cutting pliers so it can be pulled off the Axle.
4. Remove the Pneumatic Wheel from the Axle.

**Note:** There are spacers behind the wheel that must remain on the Axle when the Pneumatic Wheel is replaced.

**Note:** File off any marks in the Axle if Wheel will not slide on easily.

5. Install the Pneumatic Wheel onto the Axle and against the Spacer with the Valve side out.
6. Place a new Push Nut w/Cap over the Axle and tap it on with a Soft Faced Hammer.
7. Check the Pneumatic Wheels for proper air pressure (see “Check the Tire Pressure” in Chapter 2).

## Removing and Replacing the Clutch

### WARNING

The flywheel will still rotate for A WHILE after the engine is shut off. Shut down the engine, wait for all moving parts to come to a complete stop, remove spark plug wire, then wait 5 minutes before moving or working on the chipper.

The design of the Clutch on your machine is for rugged, dependable service; however, it is important to understand the limitations of a Clutch. The Clutch provides load free starting of the Engine and provides slippage under excessive overloading of the driven application. These features help protect the Engine from damage such as broken crankshafts and starters. The Shoes and Springs on the Clutch are normal wear items. If you notice decreased performance of the Clutch, check and replace them if necessary.

The Clutch obtains its power from the Engine RPM. The lower the engagement speed, and the higher the maintained Engine speed, the more torque the Clutch can transfer to the driven unit. **NEVER operate the DR 11.5 SELF-FEEDING CHIPPER Engine at less than full RPM when chipping.**

**Note:** *At engine start-up, the engine of your chipper operates under no load until approximately 1800 RPM, at which speed the centrifugal clutch engages and begins driving the rotor.*

### NOTICE

- Do not tamper with the engine's governor setting. The governor controls the maximum safe operation speed and protects the engine. Over-speeding the engine is dangerous and will cause damage to the engine and to the other moving parts of the machine. See your authorized dealer for any engine governor adjustments.
- Become familiar with successful operating conditions and avoid those that can overload and damage the machine.
- Do not overload or attempt to chip material beyond manufacturers recommendation. Personal injury or damage to the machine could result. Learn to recognize the sound of the machine during an overload condition. Only your operator experience will tell you how fast you can successfully feed material into the machine.
- If overloading or any other cause jams the machine, stop the machine immediately. If you jam the machine and do not stop the engine, it can burn the drive belt and/or ruin the clutch. Clutch damage can be costly and it may not be covered under warranty. For this reason, it is important that you immediately shut off the machine if it becomes jammed.
- The centrifugal clutch on this machine is permanently lubricated and does not require oil or grease. If, after long periods of use, the drum wobbles excessively, replace the clutch assembly. Always replace shoes and springs in sets. Whenever shoes are changed, replace all springs.

## Installing a new Clutch Assembly

**Note:** If a Clutch part malfunctions, it could jeopardize the integrity of other Clutch components. If you have problems with the Clutch, a Clutch Kit is available, but we recommend replacing your Clutch as a complete assembly.

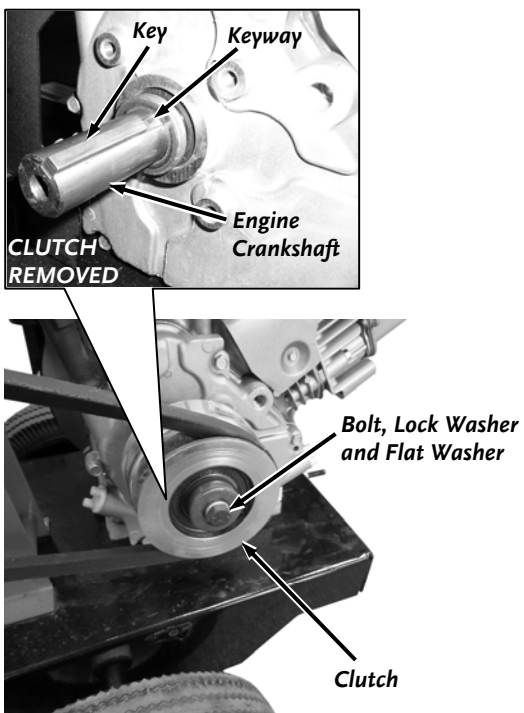

**Figure 42**

### **Tools and Supplies Needed:**

- 9/16" Wrench
  - Anti-seize compound
1. Remove the Belt Guard and Belt (see "Removing and Replacing the Drive Belt" in this Chapter).
  2. With a 9/16" wrench, remove the Clutch Bolt, Lock Washer and Flat Washer and then slide the Clutch from the Crankshaft (**Figure 42**).
  3. Remove the Key from the keyway in the Engine Crankshaft and set it aside.
  4. Clean the engine crankshaft and remove any burrs, then apply Anti-seize compound to the Crankshaft.
  5. Install the Key in the keyway of the new Clutch hub, align the Key with the slot in the Engine Crankshaft, and then slide the new Clutch Assembly onto the crankshaft followed by the Washer, Lock Washer and Clutch Bolt. Tighten the Bolt securely with a 9/16" wrench.
  6. Reinstall the Drive Belt and set the Drive Belt tension and alignment (see "Removing and Replacing the Drive Belt" in this Chapter).
  7. Reinstall the Belt Guard (see "Removing and Replacing the Drive Belt" in this Chapter).

## Chapter 5: Troubleshooting

Most problems are easy to fix. Consult the Troubleshooting Table below for common problems and their solutions. If you continue to experience problems, **contact us at [www.DRpower.com](http://www.DRpower.com) or call 1-800-DR-OWNER (376-9637)** for support.

### **WARNING**

The flywheel will still rotate for A WHILE after the engine is shut off. Shut down the engine, wait for all moving parts to come to a complete stop, remove spark plug wire, then wait 5 minutes before moving or working on the chipper.

### Troubleshooting Table

| SYMPTOM                                                                                                                                                    | POSSIBLE CAUSE                                                                                                                                                                                                                                                                                                                                                                                                                                                                                                                                                                                                                                                                                                                                                                                                                                                                                                                                                                                                                                                                               |
|------------------------------------------------------------------------------------------------------------------------------------------------------------|----------------------------------------------------------------------------------------------------------------------------------------------------------------------------------------------------------------------------------------------------------------------------------------------------------------------------------------------------------------------------------------------------------------------------------------------------------------------------------------------------------------------------------------------------------------------------------------------------------------------------------------------------------------------------------------------------------------------------------------------------------------------------------------------------------------------------------------------------------------------------------------------------------------------------------------------------------------------------------------------------------------------------------------------------------------------------------------------|
| <p><i>The engine won't start</i></p> <p><i>(Please refer to the Engine Owner's manual for engine-specific procedures.)</i></p>                             | <ul style="list-style-type: none"> <li>⇒ Is the Fuel Shut-Off Valve in the ON position?</li> <li>⇒ Is the spark plug wire attached?</li> <li>⇒ Is the Fuel Tank empty?</li> <li>⇒ If your DR 11.5 SELF-FEEDING CHIPPER still won't start, contact us at <b><a href="http://www.DRpower.com">www.DRpower.com</a> or call 1(800) DR-OWNER (376-9637)</b> for assistance.</li> </ul>                                                                                                                                                                                                                                                                                                                                                                                                                                                                                                                                                                                                                                                                                                            |
| <p><i>The engine lacks power or is not running smoothly.</i></p> <p><i>(Please refer to the Engine Owner's Manual for engine-specific procedures.)</i></p> | <ul style="list-style-type: none"> <li>⇒ Check the Throttle Lever travel and adjustment. Is the Throttle Lever in the RUN position?</li> <li>⇒ Is the Choke lever pushed all the way over to the RUN position? See Chapter 3.</li> <li>⇒ Is the air filter clean? If it's dirty, change it following the procedure in the Engine Owner's Manual.</li> <li>⇒ Is the spark plug clean? If it is fouled or cracked, change it. If it is oily, leave it out, hold a rag over the spark plug hole and pull the starter cord for a few times to blow out any oil in the cylinder, then wipe off the spark plug and reinsert it.</li> <li>⇒ Are you using fresh, clean unleaded gas? If it's old, change it. Use a fuel stabilizer if you keep gas longer than two weeks or so.</li> <li>⇒ Does your engine have the right amount of clean oil? If it's dirty, change it following the procedure in Chapter 3.</li> <li>⇒ If your engine still lacks power, contact us at <b><a href="http://www.DRpower.com">www.DRpower.com</a> or call 1(800) DR-OWNER (376-9637)</b> for assistance.</li> </ul> |
| <p><i>Engine smokes.</i></p>                                                                                                                               | <ul style="list-style-type: none"> <li>⇒ Check the oil level and adjust as needed.</li> <li>⇒ You may be operating the machine on too great an incline. The machine should be level.</li> <li>⇒ Check the air filter and clean or replace if needed.</li> <li>⇒ You may be using the wrong oil - too light for the temperature. Refer to your Engine Owner's Manual for detailed information.</li> <li>⇒ Clean the engine cooling fins and the carburetor housing if they're dirty.</li> <li>⇒ If the engine still smokes, contact us at <b><a href="http://www.DRpower.com">www.DRpower.com</a> or call 1(800) DR-OWNER (376-9637)</b> for assistance.</li> </ul>                                                                                                                                                                                                                                                                                                                                                                                                                           |
| <p><i>Chipping action seems too slow or flywheel stalls.</i></p>                                                                                           | <ul style="list-style-type: none"> <li>⇒ The engine speed is too slow causing the belt to slip. Run the engine at full throttle.</li> <li>⇒ Check for a loose or damaged Drive Belt; tighten or replace. See Chapter 4.</li> <li>⇒ Check for a dull or damaged Knife; sharpen or replace the Knife. See Chapter 4.</li> </ul>                                                                                                                                                                                                                                                                                                                                                                                                                                                                                                                                                                                                                                                                                                                                                                |
| <p><i>The belt frays or rolls over the pulley.</i></p>                                                                                                     | <ul style="list-style-type: none"> <li>⇒ The rotor Drive Pulley groove may be nicked. Check the Drive Belts for wear and hard spots. File off any nicks on the pulley.</li> <li>⇒ The Drive Belts may be stretched; replace them. See Chapter 4.</li> <li>⇒ The Pulleys may be misaligned.</li> </ul>                                                                                                                                                                                                                                                                                                                                                                                                                                                                                                                                                                                                                                                                                                                                                                                        |

## Troubleshooting Table (continued)

| SYMPTOM                                                                                                                      | POSSIBLE CAUSE                                                                                                                                                                                                                                                                                                                                                                                                                                                                                                                |
|------------------------------------------------------------------------------------------------------------------------------|-------------------------------------------------------------------------------------------------------------------------------------------------------------------------------------------------------------------------------------------------------------------------------------------------------------------------------------------------------------------------------------------------------------------------------------------------------------------------------------------------------------------------------|
| <ul style="list-style-type: none"> <li>- Clutch overheats.</li> <li>- Belt burns.</li> <li>- Flywheel won't turn.</li> </ul> | <ul style="list-style-type: none"> <li>⇒ Immediately stop the engine and disconnect the spark plug wire.</li> <li>⇒ Turn the Flywheel with a wooden stick to be sure it turns freely.</li> <li>⇒ Check for a loose Drive Belt. See Chapter 4.</li> <li>⇒ Remove any built up debris from the Chipper Hopper Inlet and Discharge Chute.</li> </ul>                                                                                                                                                                             |
| <p>The machine has excessive vibration.</p>                                                                                  | <ul style="list-style-type: none"> <li>⇒ Check for a dull or damaged Knife; sharpen or replace the Knife. See Chapter 4.</li> <li>⇒ The Knife is not properly seated on the flywheel. Loosen the Knife mounting screws, reset the Knife and tighten the screws. Also, check the Knife to Wear Plate Gap. See Chapter 4.</li> <li>⇒ If the machine still exhibits excessive vibration, contact us at <a href="http://www.DRpower.com">www.DRpower.com</a> or call 1(800) <b>DR-OWNER (376-9637)</b> for assistance.</li> </ul> |
| <p>When chipping, the log seems to vibrate excessively and "hammers" my hands.</p>                                           | <ul style="list-style-type: none"> <li>⇒ The Knife is dull; sharpen or replace it. See Chapter 4.</li> <li>⇒ The gap between the Knife and Wear Plate is too great; adjust the Gap. See Chapter 4.</li> <li>⇒ Check Engine rpms; run Engine at full throttle when chipping.</li> </ul>                                                                                                                                                                                                                                        |
| <p>Does not seem to feed as well</p>                                                                                         | <ul style="list-style-type: none"> <li>⇒ The Knife is dull; sharpen or replace it. See Chapter 4.</li> <li>⇒ Check Engine rpms; run Engine at full throttle when chipping.</li> </ul>                                                                                                                                                                                                                                                                                                                                         |
| <p>Chipper Knife is hitting the Wear Plate.</p>                                                                              | <ul style="list-style-type: none"> <li>⇒ The gap between the Knife and the Wear Plate is set incorrectly; adjust the Knife to Wear Plate Gap. See Chapter 4.</li> </ul>                                                                                                                                                                                                                                                                                                                                                       |
| <p>Engine runs but the flywheel doesn't rotate.</p>                                                                          | <ul style="list-style-type: none"> <li>⇒ The inner Shoes of the Clutch are worn. Replace worn or broken Clutch. See Chapter 4.</li> <li>⇒ Loose Drive Belt; adjust the Drive Belt tension. See Chapter 4.</li> <li>⇒ Remove any built-up debris from the Chipper Hopper Inlet and Discharge Chute.</li> </ul>                                                                                                                                                                                                                 |
| <p>The machine's wheels track left or right while being towed.</p>                                                           | <ul style="list-style-type: none"> <li>⇒ Check the tire pressure to make sure it matches the psi listed on the tire.</li> </ul>                                                                                                                                                                                                                                                                                                                                                                                               |



## Chapter 6: Chipper Accessories

### **! WARNING**

The flywheel will still rotate for A WHILE after the engine is shut off. Shut down the engine, wait for all moving parts to come to a complete stop, remove spark plug wire, then wait 5 minutes before moving or working on the chipper.

### **Pin-Hitch Package**

The Pin-Hitch Package enables your DR 11.5 SELF-FEEDING CHIPPER to be towed behind your lawn tractor. Although the Chipper is very easy to move by hand, this accessory is helpful for moving over greater distances and provides better stability when connected to your tractor.

#### **Tools and Supplies Needed:**

- Two 9/16" wrenches
- Two 1/2" wrenches

#### **Unpacking**

##### **Parts supplied (Figure 43):**

- Two Hitch Supports
- Tow Beam/Stand
- Hitch Plate
- Hardware Package containing:
  - Hand Pin
  - Clevis Pin
  - Two Hitch Clips
  - Two 5/16-18 x 1" Long Bolts
  - Two 5/16-18 Locknuts

**Note:** Compare the contents of the Parts Box with the Parts Supplied list. If there are any questions contact us at [www.DRpower.com](http://www.DRpower.com) or call 1-800-DR-OWNER (376-9637). Do not discard the shipping materials until you are fully satisfied with your new Pin-Hitch Package.

#### **Installation**

1. Support the Base of the Chipper to lift the Front Foot off the ground (**Figure 44**).
2. Remove the four Bolts and Locknuts from the Front Foot using two 9/16" Wrenches. Remove and store the Front Support for future use.
3. Install the two Hitch Supports onto the Frame as shown with the four Bolts and Locknuts you removed earlier using two 9/16" wrenches (**Figure 45**). Leave the Hardware loose for now.

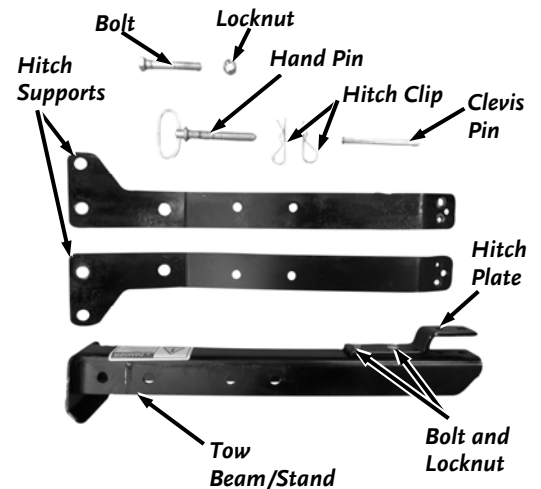

Figure 43

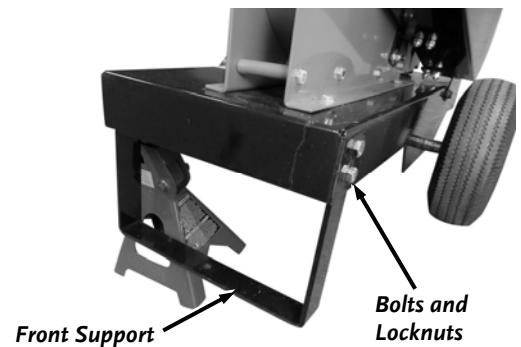

Figure 44

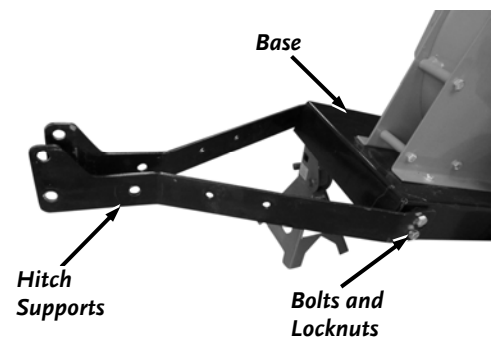

Figure 45

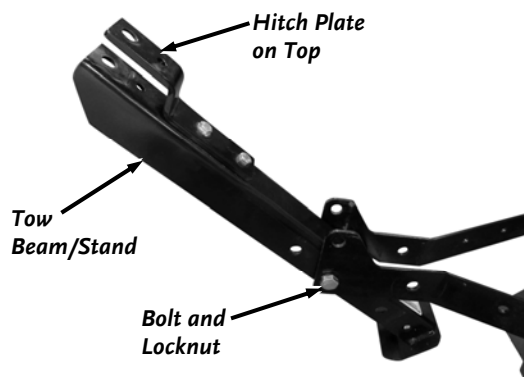

Figure 46

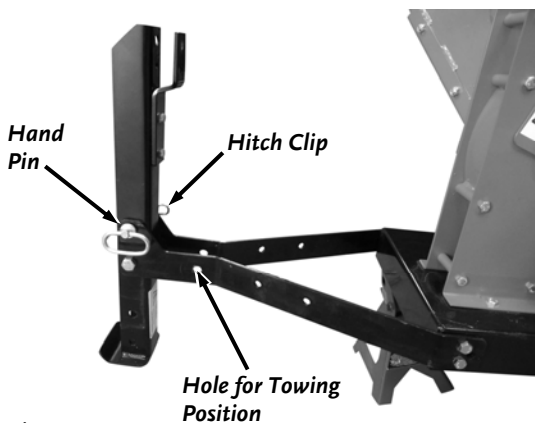

Figure 47

4. Secure the Tow Beam/Stand to the Hitch Supports with the 3/8-16 X 3" Bolt and Locknut using two 9/16" Wrenches (**Figure 46**). Do not over tighten because the Tow Beam/Stand must be able to rotate between the Hitch Supports.
5. Tighten the Hardware that secures the Hitch Supports to the Frame (**Figure 45**).
6. Position the Tow Beam/Stand so it is vertical and install the Hand Pin and Hitch Clip to secure it in the upright position (**Figure 47**). This is the operating Position when the machine is off the tow vehicle.
7. When attaching to a tow vehicle, position the Tow Beam/Stand so it is horizontal and install the Hand Pin and Hitch Clip and secure to the tow vehicle with the Clevis Pin and Hitch Clip.

**⚠ DANGER**

Avoid Death or Serious Injury. Do not tow this machine faster than 10 mph. This machine is not legal for street or highway use.



## Chapter 7: Parts List and Schematic Diagrams

### Parts List and Schematic - Chipper Basic Assembly

Note: Part numbers listed are available through DR Power Equipment.

| Ref# | Part# | Description                            | Ref# | Part# | Description                         |
|------|-------|----------------------------------------|------|-------|-------------------------------------|
| 1    | 37268 | Flywheel, Weldment                     | 10   | 37251 | Scroll, Tube                        |
| 2    | 37262 | Plate, Hopper Side, Chipper Housing    | 11   | 14065 | Knife, CPR                          |
| 3    | 37265 | Scroll, Weldment                       | 12   | 27645 | Bolt, FHCS, 5/16-18 x 1 1/4", Alloy |
| 4    | 37266 | Chute, Discharge, Low                  | 13   | 37254 | Plate, Wear, 10 Ga                  |
| 5    | 37263 | Plate, Discharge Side, Chipper Housing | 14   | 19566 | Bolt, Carriage, 1/4-20 x 1"         |
| 6    | 14313 | Nut, Nylon Lock, 5/16-18               | 15   | 14339 | Washer, Flat, 1/4", SAE             |
| 7    | 37269 | Cover, Access, 3 Hole                  | 16   | 14705 | Bolt, HHCS, 5/16-18 x 3-1/2", Gr 5  |
| 8    | 18444 | Bearing, 2 Bolt, 1 In                  | 17   | 14340 | Nut, Nylon Lock, 1/4-20             |
| 9    | 30508 | Ring, Retaining                        | 18   | 37397 | Cover, Access, 2 Hole               |

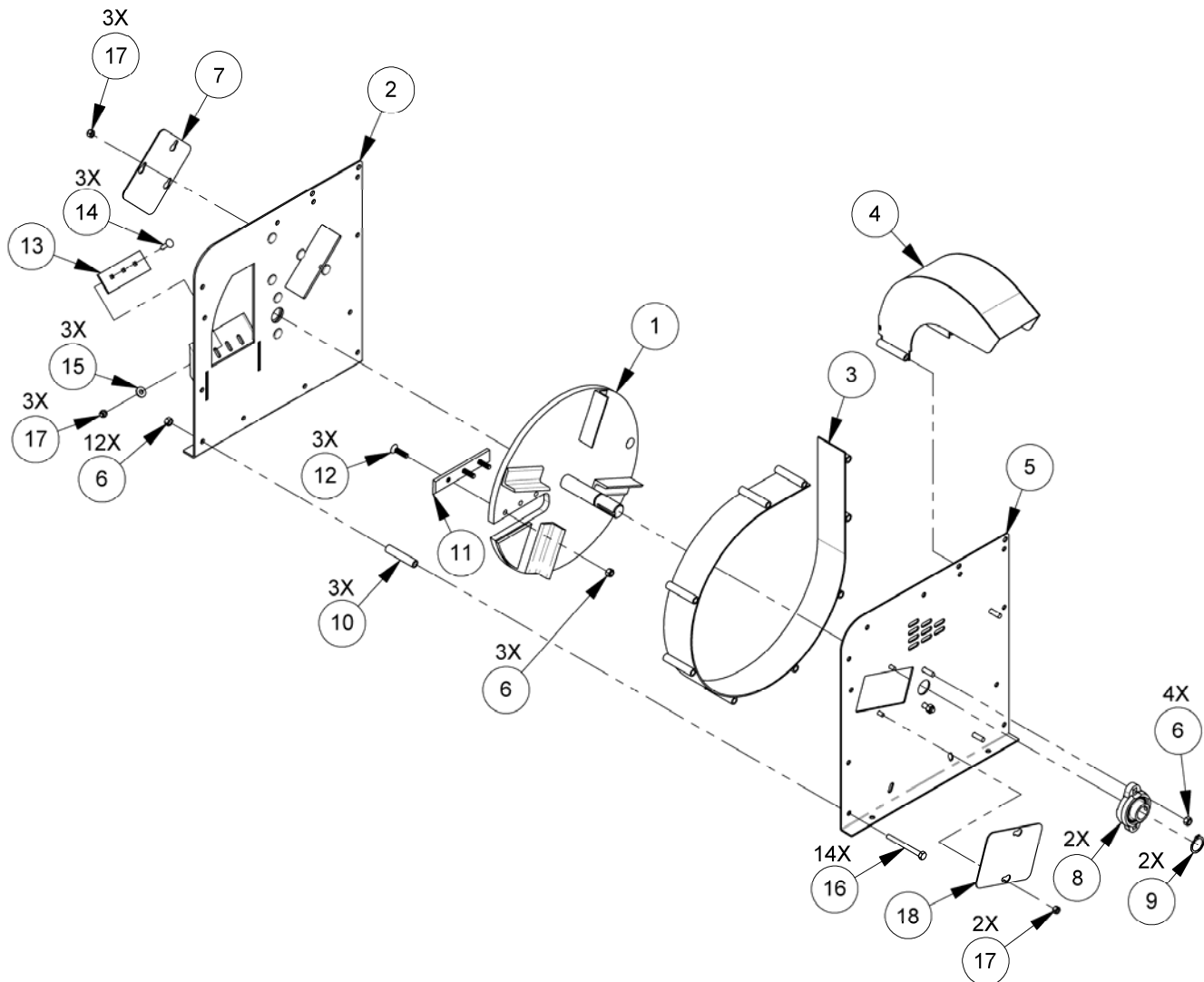

## Parts List and Schematic – Base and Wheels Assembly

**Note:** Part numbers listed are available through DR Power Equipment.

| Ref# | Part# | Description                  | Ref# | Part# | Description                  |
|------|-------|------------------------------|------|-------|------------------------------|
| 1    | 16679 | Bolt, HHCS, 5/16-18 x 3/4"   | 8    | 37250 | Stand, Front                 |
| 2    | 14313 | Nut, Nylon Lock, 5/16-18     | 9    | 37261 | Guard, Belt, Asm             |
| 3    | 37252 | Bracket, Belt Guard, Int Mnt | 10   | 37253 | Bracket, Belt Guard, Ext Mnt |
| 4    | 37255 | Axle                         | 11   | 37264 | Frame                        |
| 5    | 37260 | Spacer, Wheel                | 12   | 15448 | Nut, Nylon Lock, 3/8-16      |
| 6    | 15465 | Tire/Wheel, CPR, 4.10/3.50-4 | 13   | 29263 | Bolt, HHCS, 3/8-16 x 1", Gr5 |
| 7    | 15488 | Push Cap, w/Spring Washer    |      |       |                              |

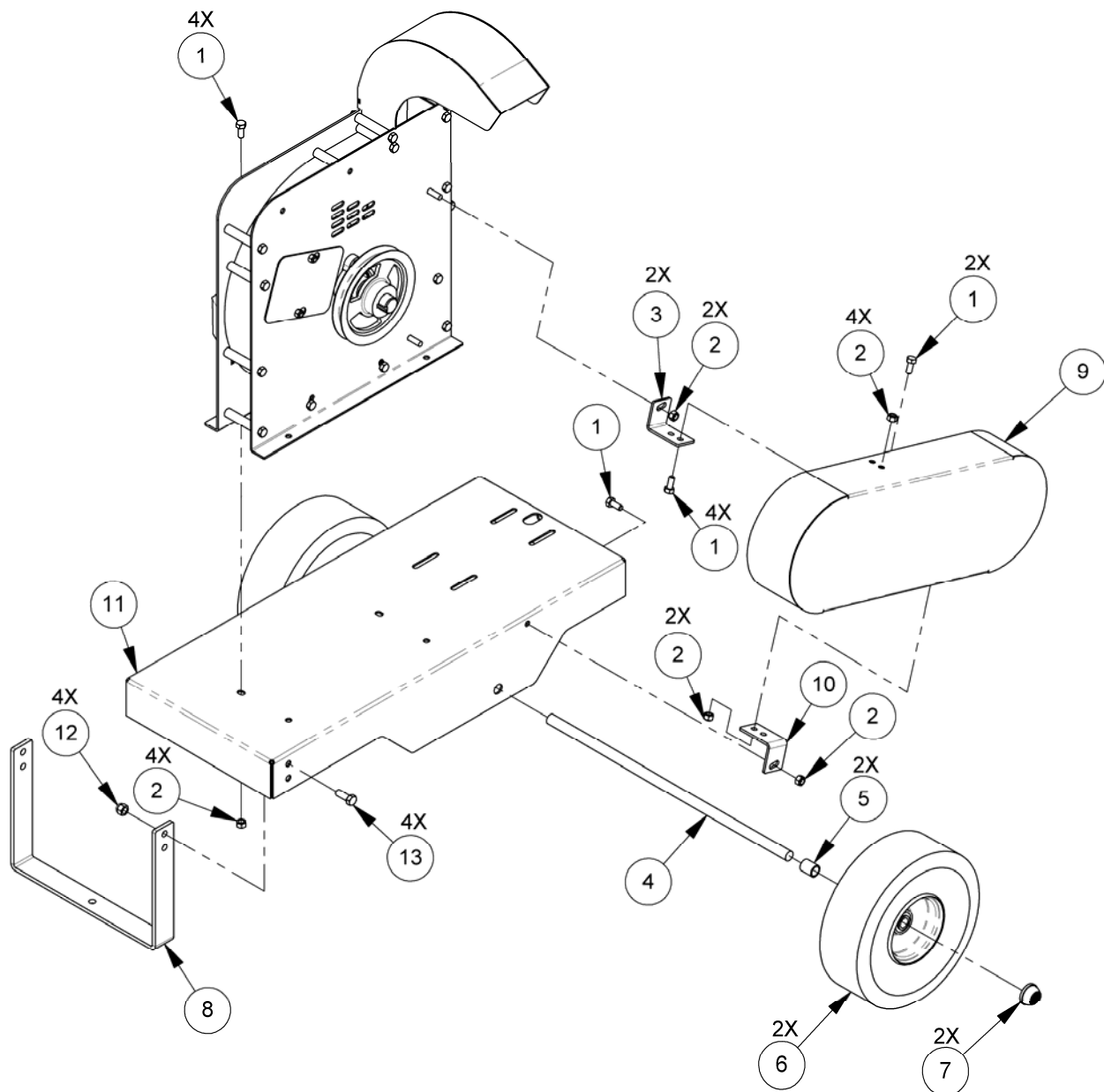

## Parts List – Hopper Assembly

**Note:** Part numbers listed are available through DR Power Equipment.

| <u>Ref#</u> | <u>Part#</u> | <u>Description</u>                       | <u>Ref#</u> | <u>Part#</u> | <u>Description</u>                       |
|-------------|--------------|------------------------------------------|-------------|--------------|------------------------------------------|
| 1           | 37257        | Chute, Hopper, Bottom                    | 8           | 24162        | Bolt, Philips Head, 5/16-18 x 1/2", Gr 5 |
| 2           | 37258        | Chute, Hopper, Left                      | 9           | 37273        | Shield, Blow Back                        |
| 3           | 37267        | Mount, Hopper                            | 10          | 37276        | Support, Blow Back                       |
| 4           | 37256        | Chute, Hopper, Top                       | 11          | 14339        | Washer, Flat, 1/4-20                     |
| 5           | 37259        | Chute, Hopper, Right                     | 12          | 29286        | Bolt, HHCS, 1/4-20 x 3/4", Gr 5          |
| 6           | 18755        | Nut Nylon Lock 5/16-18 LP                | 13          | 14340        | Nut, Nylon Lock, 1/4-20                  |
| 7           | 37274        | Bolt, Philips Head, 5/16-18 x 3/4", Gr 5 |             |              |                                          |

**Schematic – Hopper Assembly**

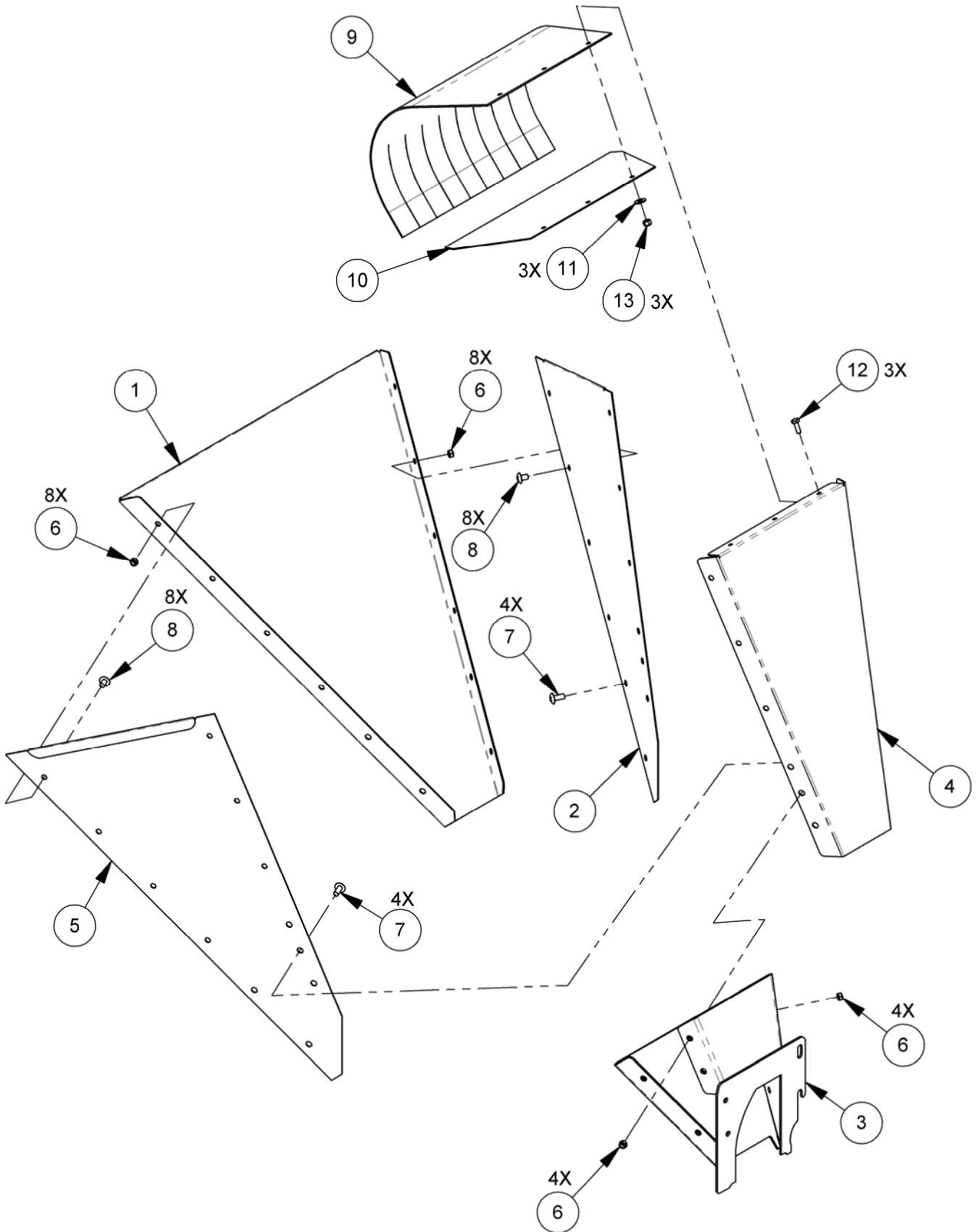

## Parts List – Drive Assembly

**Note:** Part numbers listed are available through DR Power Equipment.

| <u>Ref#</u> | <u>Part#</u> | <u>Description</u>                       | <u>Ref#</u> | <u>Part#</u> | <u>Description</u>                |
|-------------|--------------|------------------------------------------|-------------|--------------|-----------------------------------|
| 1           | 24167        | Engine, Briggs and Stratton, 1100 Series | 10          | 37247        | Tensioner, Belt                   |
| 2           | 15979        | Bolt, HHCS, 5/16-18 x 1 3/4", Gr 5       | 11          | 37271        | Belt, V, 5L X 44.00               |
| 3           | 15526        | Shim                                     | 12          | 37272        | Pulley, 5L, 1.00 bore x 6.00 OD   |
| 4           | 37270        | Clutch                                   | 13          | 13327        | Key, Shaft, 1/4" SQ x 1"          |
| 5           | 16208        | Washer, 1.5 OD .390 ID .156 Thick        | 14          | 24197        | Bolt, 5/16-18 x 4-1/2", Gr5       |
| 6           | 21651        | Washer, Lock, Split, 3/8"                | 15          | 29260        | Bolt, HHCS, 5/16-18 x 1-1/2", Gr5 |
| 7           | 16513        | Bolt, HHCS, 3/8-24 x 1 1/4", Gr 8        | 16          | 37248        | Handle                            |
| 8           | 14313        | Nut, Nylon Lock, 5/16-18                 | 17          | 20881        | Grip, Handle                      |
| 9           | 14515        | Washer, Flat, 5/16"                      | 18          | 14444        | Key, Shaft, 1/4" sq x 2"          |



# Schematic – Drive Assembly

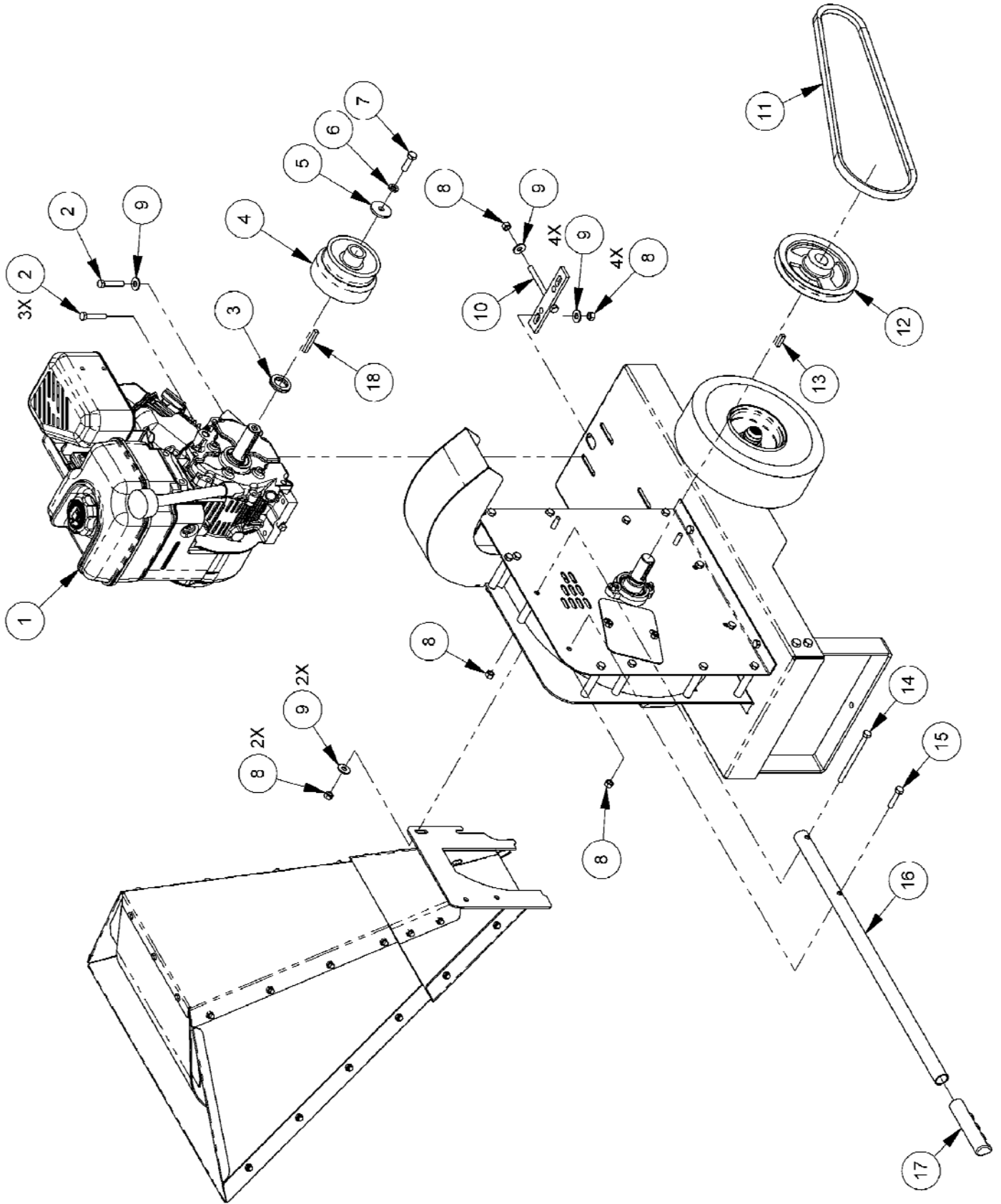

## Parts List and Schematic – Pin Hitch Assembly

**Note:** Part numbers listed are available through DR Power Equipment.

| Ref# | Part# | Description                         | Ref#             | Part# | Description                      |
|------|-------|-------------------------------------|------------------|-------|----------------------------------|
| 1    | 14292 | Hitch Plate,-Bent                   | 7                | 15448 | Locknut, Nylon Insert, 3/8-16, P |
| 2    | 14605 | Bolt, 5/16-18 X 1" HHCS GR 5 PLTD   | 8                | 37326 | Tow Tongue Weldment, Non Highway |
| 3    | 14313 | Locknut, Nylon Insert, 5/16-18, P   | 9                | 37327 | Ring Pin, 3/8" X 2 3/4", ZP      |
| 4    | 37324 | Hitch Arm, Small, Right Hand        | 10               | 18258 | Hair Spring Cotter, 1/8", PLTD   |
| 5    | 37325 | Hitch Arm, Small, Left Hand         | <b>Not Shown</b> |       |                                  |
| 6    | 21714 | Bolt, HHCS, 3/8-16 X 3", GR 5, PLTD | 24204            |       | Decal, Danger, 10mph Tow         |

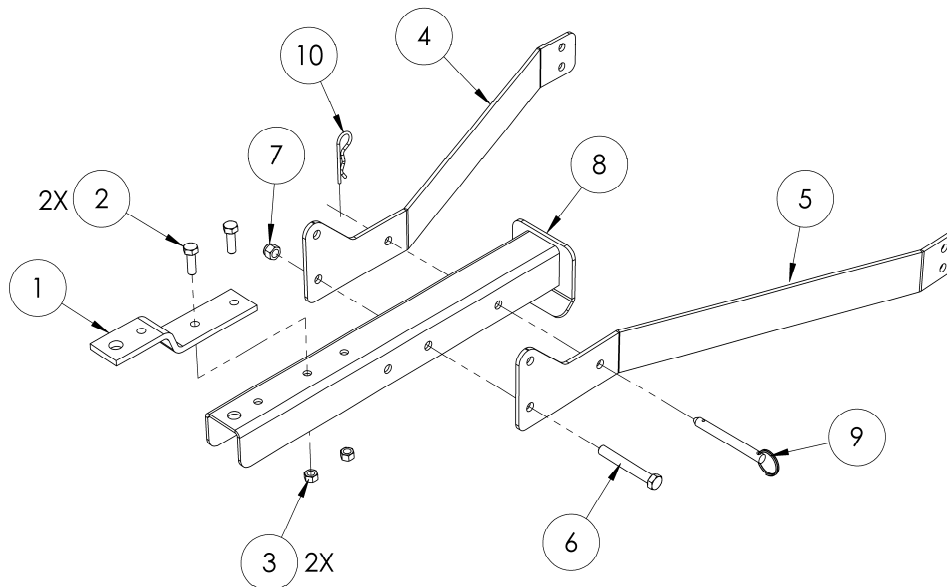

# DR<sup>®</sup> 11.5 SELF-FEEDING CHIPPER



## 2-Year Limited Warranty

### Terms and Conditions

The DR<sup>®</sup> 11.5 SELF-FEEDING CHIPPER is warranted for two (2) years against defects in materials or workmanship when put to ordinary and normal consumer use; ninety (90) days for any other use.

For the purposes of all the above warranties, "ordinary and normal consumer use" refers to non-commercial residential use and does not include misuse, accidents or damage due to inadequate maintenance.

DR<sup>®</sup> Power Equipment certifies that the DR<sup>®</sup> 11.5 SELF-FEEDING CHIPPER is fit for ordinary purposes for which a product of this type is used. DR Power Equipment however, limits the implied warranties of merchantability and fitness in duration to a period of two (2) years in consumer use, ninety (90) days for any other use.

The 2-Year Limited Warranty on the DR<sup>®</sup> 11.5 SELF-FEEDING CHIPPER starts on the date the machine ships from our factory. The 2-Year Limited Warranty is applicable only to the original owner.

The warranty holder is responsible for the performance of the required maintenance as defined by the manufacturer's owner's manuals. The warranty holder is responsible for replacement of normally wearing parts such as the Drive Belt, Knife, Wear Plate, Tires, Air Filter and Spark Plug. Attachments and accessories to the machine are not covered by this warranty.

During the warranty period, the warranty holder is responsible for the machine transportation charges, if required. During the warranty period, warranty parts will be shipped by standard method at no charge to the warranty holder. Expedited shipping of warranty parts is the responsibility of the warranty holder.

SOME STATES DO NOT ALLOW LIMITATIONS ON THE LENGTH OF IMPLIED WARRANTIES, SO THE ABOVE LIMITATIONS MAY NOT APPLY TO YOU.

DR Power Equipment shall not be liable under any circumstances for any **incidental or consequential damages or expenses** of any kind, including, but not limited to, cost of equipment rentals, loss of profit, or cost of hiring services to perform tasks normally performed by the DR<sup>®</sup> 11.5 SELF-FEEDING CHIPPER.

SOME STATES DO NOT ALLOW THE EXCLUSION OR LIMITATION OF INCIDENTAL OR CONSEQUENTIAL DAMAGES, SO THE ABOVE LIMITATIONS MAY NOT APPLY TO YOU.

THIS WARRANTY GIVES YOU SPECIFIC LEGAL RIGHTS, AND YOU ALSO HAVE OTHER RIGHTS, WHICH VARY FROM STATE TO STATE.

## Daily Checklist for the DR 11.5 SELF-FEEDING CHIPPER

To help maintain your DR 11.5 SELF-FEEDING CHIPPER for optimum performance, we recommend you follow this checklist each time you use your Chipper.

### WARNING

The flywheel will still rotate for A WHILE after the engine is shut off. Shut down the engine, wait for all moving parts to come to a complete stop, remove spark plug wire, then wait 5 minutes before moving or working on the chipper.

- [ ] OIL: With the machine on a level surface, check the Engine oil level with the Dipstick and add more if necessary (only add oil to the level indicated on the Dipstick - DO NOT OVERFILL). Use SAE 30 high detergent motor oil.
- [ ] GAS: Fill the Fuel Tank with clean, fresh, unleaded gasoline.
- [ ] ENGINE AIR COOLING SYSTEM: It is very important to keep the Engine clean of debris. Remove leaves and other built-up materials from the Air Intake Screen before, during, and after using the Chipper. Regularly remove debris from the Cooling Fins. A dirty Engine retains heat and can cause damage to the internal Engine parts.
- [ ] BELT: Check the Belt for wear, proper alignment and tension.
- [ ] KNIFE: Check the Knife.
- [ ] GENERAL CONDITION: Check the general condition of the machine, e.g.; nuts, bolts, welds, etc.
- [ ] HOPPER: Check that there is no material left in the hopper before starting the Chipper.
- [ ] TIRES: Check that there is the proper amount of air in the Tires.

### End of Season and Storage

### WARNING

The flywheel will still rotate for A WHILE after the engine is shut off. Shut down the engine, wait for all moving parts to come to a complete stop, remove spark plug wire, then wait 5 minutes before moving or working on the chipper.

**Note:** Please refer to the Engine Owner's Manual for engine-specific procedures.

- Never store the DR 11.5 SELF-FEEDING CHIPPER with fuel in the fuel tank inside a building where ignition sources are present, such as hot water and space heaters, clothes dryers and the like. If you are going to drain the fuel tank, do this outdoors. Allow the engine to cool before storing in any enclosure.
- When not in use, your DR 11.5 SELF-FEEDING CHIPPER should be stored out of the reach of children.
- Change the oil. Refer to your Engine Owner's Manual for detailed information.
- If your DR 11.5 SELF-FEEDING CHIPPER will be idle for more than 30 days, we recommend using a gas stabilizer. This will prevent sediment from gumming up the carburetor. If there is dirt or moisture in the gas or tank, remove it by draining the tank. Completely fill the tank with fresh, unleaded gas and add the appropriate amount of stabilizer or gasoline additive. Run the engine for a short time to allow the additive to circulate. Close the Fuel Shut-Off Valve to prevent carburetor overflow and leakage.
- Remove the spark plug and pour about 1 ounce of motor oil into the cylinder hole. Reinstall the plug and pull the starter cord a few times. This will coat the pistons and seat the valves to prevent moisture buildup.
- Clean or replace the air filter.
- Lubricate all grease fittings.
- Clean any dirt and debris from the cylinder head cooling fins, blower housing, debris screen and muffler area of the engine.
- Check the Drive Belt for wear.
- Check the Chipper Knife and Wear Plate for nicks and wear.
- Clean any debris from the Hopper and Discharge Chute.



DR® POWER EQUIPMENT

75 MEIGS ROAD, P.O. BOX 25, VERGENNES, VERMONT 05491