

DR[®] CHIPPER/SHREDDER

SAFETY & OPERATING INSTRUCTIONS



Serial No. _____

Order No. _____

Original Language

DR Power Equipment
Toll-free phone: 1-800-DR-OWNER (376-9637)
Fax: 1-802-877-1213
Website: www.DRpower.com

! WARNING

Read and understand this manual and all instructions before operating the DR CHIPPER/SHREDDER.

Table of Contents

Chapter 1: General Safety Rules.....	3
Chapter 2: Setting Up The DR CHIPPER/SHREDDER.....	8
Chapter 3: Operating The DR CHIPPER/SHREDDER	13
Chapter 4: Maintaining The DR CHIPPER/SHREDDER	17
Chapter 5: Troubleshooting	24
Chapter 6: Parts Lists and Schematic Diagrams.....	26

Conventions used in this manual

DANGER

This indicates a hazardous situation, which, if not followed, will result in death or serious injury.

WARNING

This indicates a hazardous situation, which, if not avoided, could result in death or serious injury.

CAUTION

This indicates a hazardous situation, which, if not avoided, could result in minor or moderate injury.

NOTICE

This information is important in the proper use of your machine. Failure to follow this instruction could result in damage to your machine or property.

Serial Number and Order Number

A Serial Number is used to identify your machine and is located on the Serial Number Label on your machine. An Order Number is used to check and maintain your order history and is located on the upper left portion of your packing slip. For your convenience and ready reference, enter the Serial Number and Order Number in the space provided on the front cover of this manual.

Additional Information and Potential Changes

DR Power Equipment reserves the right to discontinue, change, and improve its products at any time without notice or obligation to the purchaser. The descriptions and specifications contained in this manual were in effect at printing. Equipment described within this manual may be optional. Some illustrations may not be applicable to your machine.

Chapter 1: General Safety Rules

! WARNING

Read this Safety & Operating Instructions Manual before you use the DR CHIPPER/SHREDDER. Become familiar with the operation and service recommendations to ensure the best performance from your machine. If you have any questions or need assistance, please contact us at www.DRpower.com or call Toll-Free 1-800-DR-OWNER (376-9637) and one of our Technical Support Representatives will be happy to help you.

Labels

Your DR CHIPPER/SHREDDER carries prominent labels as reminders for its proper and safe use. Shown below are copies of all the Safety and Information labels that appear on the equipment. Take a moment to study them and make a note of their location on your CHIPPER/SHREDDER as you set up and before you operate the unit. Replace damaged or missing Safety and Information labels immediately.



#242321



#137581

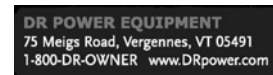

#235451



#227141

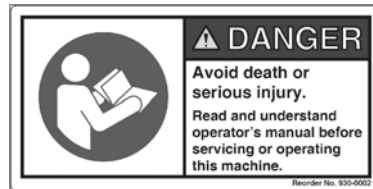

#241801



#242041



#241991



#241831

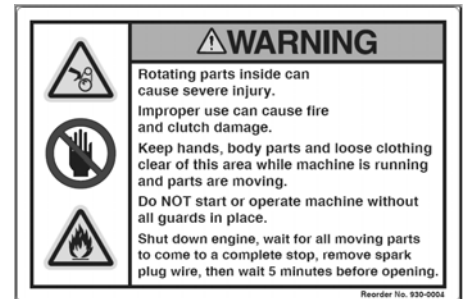

#241821

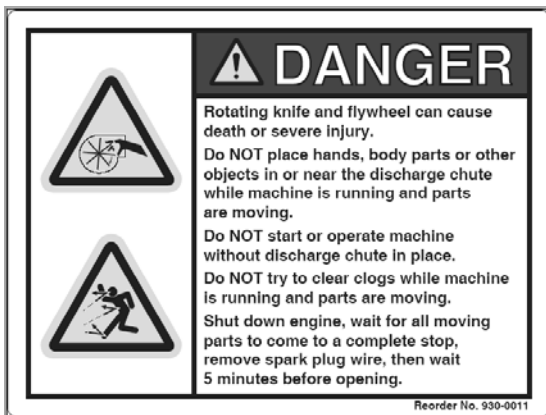

#241811



#247961

Protecting Yourself and Those Around You

WARNING

This is a high-powered machine, with moving parts operating with high energy. You must operate the machine safely. Unsafe operation can create a number of hazards for you, as well as anyone else in the nearby area. This machine can crush, grind, cut, and sever parts of your body if they enter the inlet or discharge area of your CHIPPER/SHREDDER. Always take the following precautions when using this machine:

- Keep in mind that the operator or user is responsible for accidents or hazards occurring to other people, their property, and themselves.
 - Always wear protective goggles or safety glasses with side shields while using the CHIPPER/SHREDDER to protect your eyes from possible thrown debris.
 - Avoid wearing loose clothing or jewelry, which can catch on moving parts or the material fed into the CHIPPER/SHREDDER.
 - We recommend wearing gloves while using the CHIPPER/SHREDDER. Be sure your gloves fit properly and do not have loose cuffs or drawstrings.
 - Wear shoes with non-slip treads when using your CHIPPER/SHREDDER. If you have safety shoes, we recommend wearing them. Do not use the machine while barefoot or wearing open sandals.
 - Wear long pants while operating the CHIPPER/SHREDDER.
 - Use ear protectors or earplugs rated for at least 20 dba to protect your hearing.
 - Keep bystanders at least 100 feet away from your work area. Stop the engine when another person or pet approaches.
-

Safety for Children and Pets

WARNING

Tragic accidents can occur if the operator is not alert to the presence of children and pets. Children are often attracted to the machine and the chipping/shredding activity. *Never* assume that children will remain where you last saw them. Always follow these precautions:

- Keep children and pets at least 100 feet from the working area and ensure they are under the watchful care of a responsible adult.
 - Be alert and turn the machine off if children or pets enter the work area.
 - Never allow children to operate the CHIPPER/SHREDDER.
-

Safety with Gasoline - Powered Machines

WARNING

Gasoline is a highly flammable liquid. Gasoline also gives off flammable vapor that can be easily ignited and cause a fire or explosion. Never overlook the hazards of gasoline. Always follow these precautions:

- Never run the Engine in an enclosed area or without proper ventilation as the exhaust from the Engine contains carbon monoxide, which is an odorless, tasteless, and deadly poisonous gas.
 - Store all fuel and oil in containers specifically designed and approved for this purpose and keep away from heat and open flame, and out of the reach of children.
 - Replace rubber Fuel Lines and Grommets when worn or damaged and after 5 years of use.
 - Fill the Gasoline Tank outdoors with the Engine off and allow the Engine to cool completely. Don't handle gasoline if you or anyone nearby is smoking, or if you're near anything that could cause it to ignite or explode. Reinstall the Fuel Tank Cap and Fuel Container Cap securely.
 - If you spill gasoline, do not attempt to start the Engine. Move the machine away from the area of the spill and avoid creating any source of ignition until the gas vapors have dissipated. Wipe up any spilled fuel to prevent a fire hazard and properly dispose of the waste.
 - Allow the Engine to cool completely before storing in any enclosure. Never store a machine that has gas in the tank, or a Fuel Container, near an open flame or spark such as a water heater, space heater, clothes dryer or furnace.
 - Never make adjustments or repairs with the Engine running. Shut down the Engine, disconnect the Spark Plug wire, keeping it away from the Spark Plug to prevent accidental starting, wait 5 minutes before making adjustments or repairs.
 - Never tamper with the Engine's Governor setting. The Governor controls the maximum safe operation speed and protects the Engine. Over-speeding the Engine is dangerous and will cause damage to the Engine and to the other moving parts of the machine. If required, see your authorized dealer for Engine governor adjustments.
 - Keep combustible substances away from the Engine when it is hot.
 - Never cover the machine while the Muffler is still hot.
 - Do not operate the Engine with the Air Cleaner or the Carburetor Air Intake Cover removed. Removal of such parts could create a fire hazard. Do not use flammable solutions to clean the Air Filter.
 - The Muffler and Engine become very hot and can cause a severe burn; do not touch.
-

General Safety

WARNING

Operating this CHIPPER/SHREDDER safely is necessary to prevent or minimize the risk of death or serious injury. Unsafe operation can create a number of hazards for you. Always take the following precautions when operating this machine:

- Your CHIPPER/SHREDDER is a powerful tool, not a plaything. Exercise extreme caution at all times. The machine is designed to chip wood and shred most organic materials. Do not use it for any other purpose.
- Thoroughly inspect the area in which you will be working and remove all foreign objects. Look for rope, wire, etc., and remove these objects before chipping/shredding. Inserting these objects into the CHIPPER/SHREDDER Hopper could damage the machine and/or cause injury.
- Know how to stop the CHIPPER/SHREDDER quickly; see “Stopping the Engine” in Chapter 3.
- Never operate your unit on a slippery, wet, muddy, or icy surface. Exercise caution to avoid slipping or falling.
- See manufacturer’s instructions for proper operation and installation of accessories. Only use accessories approved by DR Power Equipment.
- Never use the machine without ensuring that all guards and shields are in place.
- Never, under any conditions, remove, bend, cut, fit, weld, or otherwise alter standard parts on the CHIPPER/SHREDDER. This includes all shields and guards. Modifications to your machine could cause personal injuries and property damage and will void your warranty.
- Never use the machine with the Hopper(s) or Discharge Chute removed.
- Never place any part of your body in the CHIPPER/SHREDDER Hopper(s), discharge opening, or near any moving part while the machine is running. Keep the area of discharge clear of anything that will obstruct a clear discharge. Wind can also change discharge direction, so be aware. If it becomes necessary to push material into the CHIPPER/SHREDDER Hopper(s), use a small diameter stick, NOT WITH YOUR HANDS.
- Keep your face and body back from the CHIPPER/SHREDDER Hopper(s) to avoid accidental bounce back of any material.
- Do not allow an accumulation of processed material to build up in the discharge area as this will prevent proper discharge and can result in kickback from the CHIPPER/SHREDDER Hopper(s).
- Allow only one person to operate the CHIPPER/SHREDDER at any time.
- Always operate the machine from the Operator Zone (see **Figure 10** on page 13). Never pass or stand on the discharge side of the machine when the Engine is running or the Flywheel is turning.
- If the machine should start making an unusual noise or vibration, shut down the Engine, disconnect the Spark Plug Wire, keeping it away from the Spark Plug to prevent accidental starting, wait 5 minutes, then inspect for damage. Vibration is generally a warning of trouble. Check for damaged parts and clean, repair, and/or replace as necessary.
- Never tamper with safety devices. Check their proper operation regularly.
- Never try to pick up, move, or transport the machine while the Engine is running or the Flywheel is turning.
- Before performing any maintenance or inspection procedure on the CHIPPER/SHREDDER, shut the Engine OFF, remove the Spark Plug Wire, and keep it away from the Spark Plug.
- Never allow people who do not understand and/or have not read this Safety and Operating Instructions Manual to use the CHIPPER/SHREDDER. Allow only responsible individuals who are familiar with these rules of safe operation to use your machine.
- Never overload or attempt to Chip or Shred material beyond the manufacturer’s recommendation. Personal injury or damage to the machine could result.
- While using the CHIPPER/SHREDDER, don't hurry or take things for granted. When in doubt about the equipment or your surroundings, stop the machine and take the time to look things over.
- Never operate the machine when under the influence of alcohol, drugs, or medication.
- Use the machine only in daylight.
- Stay alert for hidden hazards or traffic.
- Keep all nuts and bolts tight and keep the equipment in good operating condition.

A Note to All Users

Under California law, and the laws of some other states, you are not permitted to operate an internal combustion engine using hydrocarbon fuels without an Engine Spark Arrester. This also applies to operation on US Forest Lands. All DR CHIPPER/SHREDDERS shipped to California, New Mexico, and Washington State are provided with Spark Arresters. Failure of the owner or operator to maintain this equipment in compliance with state regulations is a misdemeanor under California law and may be in violation of other state and/or federal regulations. Contact your State Park Association or the appropriate state organization for specific information in your area.

No list of warnings and cautions can be all-inclusive. If situations occur that are not covered by this manual, the operator must apply common sense and operate this DR CHIPPER/SHREDDER in a safe manner. Contact us at www.DRpower.com or call Toll Free: 1-800-DR-OWNER (376-9637) for assistance.

Chapter 2: Setting Up The DR CHIPPER/SHREDDER

It may be helpful to familiarize yourself with the controls and features of your DR CHIPPER/SHREDDER as shown in **Figure 1** before beginning these procedures. If you have any questions at all, please feel free to contact us at www.DRpower.com.

DR CHIPPER/SHREDDER Controls and Features

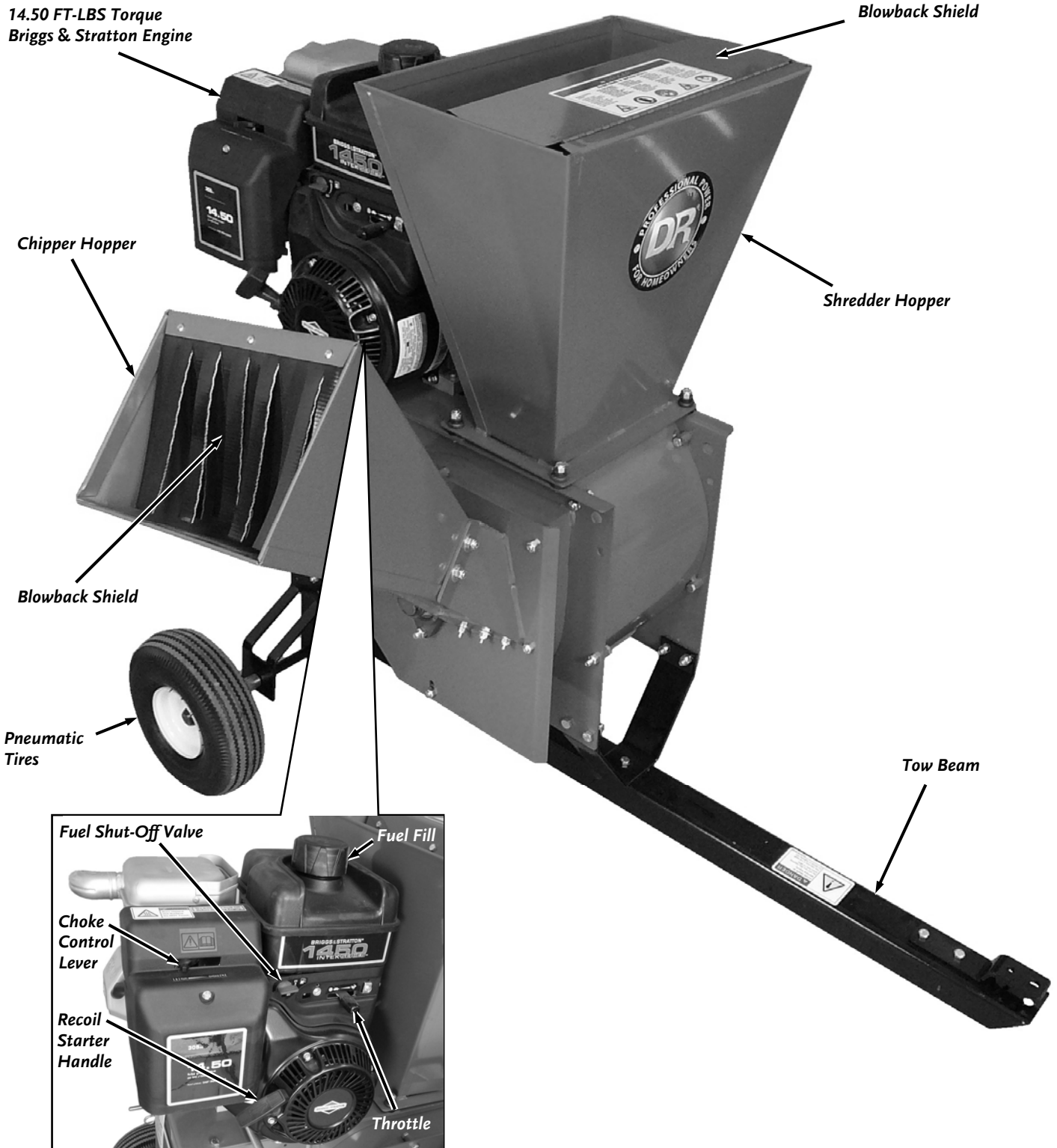

Figure 1

Specifications

Engine	14.50 FT-LBS Torque Briggs & Stratton
	Please refer to the Engine Owner's Manual for Engine-specifications.
Tire Size	10 inch diameter
Clutch	Centrifugal
Engagement speed	1,000 RPM (the Rotor will turn at idle)
Frame	Welded 12 gauge steel construction
Belt	V-Belt
Size	44 inches
Construction	Wrapped for abrasion resistance
Machine Dimensions	56" L x 41" W x 44" H
Operating Weight	235 pounds
Shipping Weight	255 pounds
Shipping Dimensions	32" L x 34" W x 59" H

Unpacking the DR CHIPPER/SHREDDER

Tools and supplies needed:

- Hammer or Pry Bar
- Wire Cutters or Utility Knife
- Gloves & Safety Glasses
- 1/2" Socket or Wrench

Compare the contents you removed from inside the Shredder Hopper with the "Parts Supplied list below (**Figure 2**). If there are any questions contact us at www.DRpower.com or call 1-800-DR-OWNER (376-9637). Do not discard the shipping materials until you are fully satisfied with your new DR CHIPPER/SHREDDER.

Parts supplied		
Item	Description	Qty
1	Tow Beam	1
	Main Chipper/Shredder Assembly	1
Parts shipped inside Shredder Hopper (Figure 2)		
2	Chipper Hopper	1
	Engine Manual	1
	Safety & Operating Instructions Manual	1
3	Safety Glasses	1
4	Hardware Bag	1
5	Bolt, Carriage, 5/16- 18 x 3/4"	4
6	Bolt, HHCS, 5/16-18 x 1"	3
7	Washer, Flat, 5/16", USS	5
8	Nut, Nylon Lock, 5/16-18	7
9	Nut, Nylon Lock, 1/4-20	2
10	U-Bolt, 1/4-20 x 1-1/4"	1
11	Hitch Plate, Bent	1
12	Gauge, Knife Gap	1

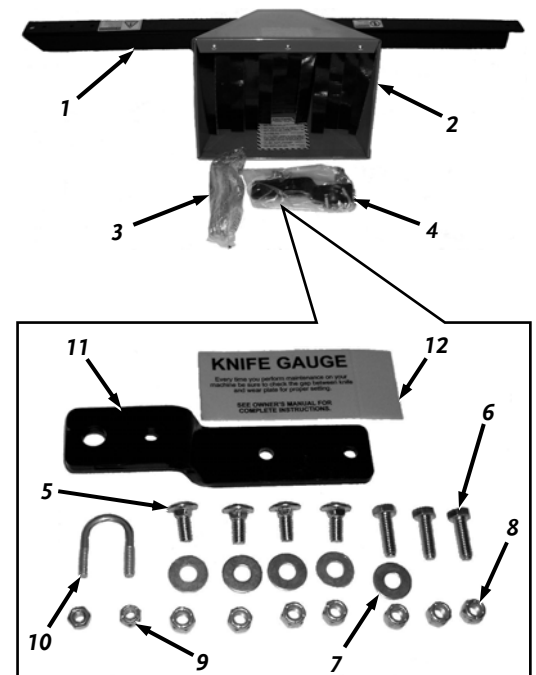

Figure 2

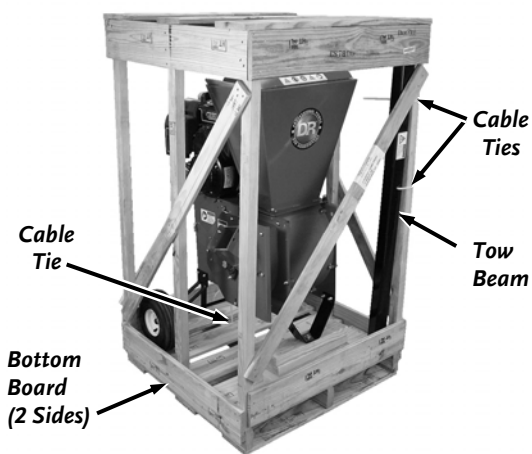

Figure 3

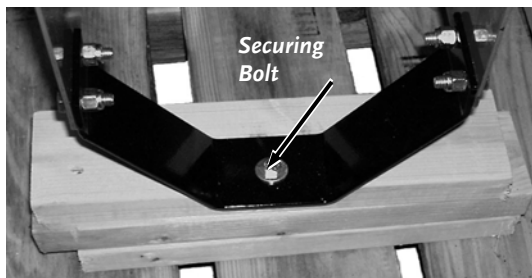

Figure 4

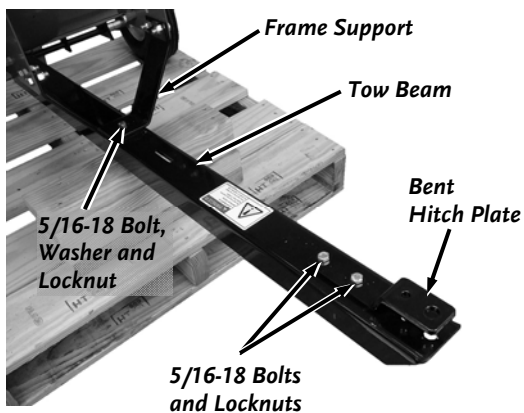

Figure 5

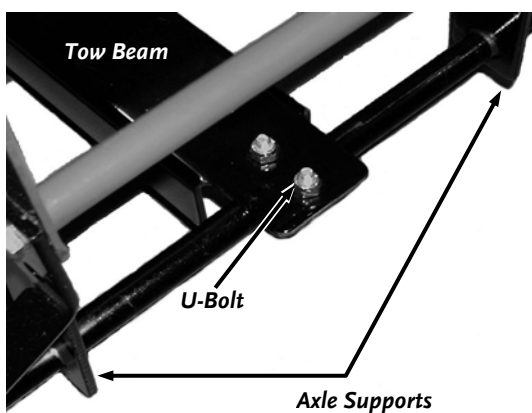

Figure 6

CAUTION

Wear Safety Glasses to protect your eyes from flying debris and Gloves to protect your hands from sharp objects when performing these procedures.

1. Cut the Cable Ties that are securing the Tow Beam to the Crate and remove the Tow Beam (**Figure 3**).
2. Pry off the two Bottom Boards where the Crate is attached to the pallet and lift the Crate off the Pallet.
3. Cut the Cable Tie securing the Chipper/Shredder to the Pallet.
4. Use a 1/2" Wrench to remove the Lag Bolt and Washer securing the front of the Chipper/Shredder frame to Shipping Pallet (**Figure 4**).
5. Leave the machine on the pallet for the next procedure.

Attaching the Tow Beam and Hitch Plate

Tools Needed:

- 7/16" Wrench
- Two 1/2" Wrenches

1. Position the Tow Beam under the Frame Support in the front (**Figure 5**) and on top of the Axle in the back (**Figure 6**). Make sure the back end of the tow beam is centered between the Axle Supports.
2. Put the U-Bolt around the Axle from underneath and up through the two holes on the Tow Beam. Install two 1/4-20 Lock Nuts on the U-Bolt with a 7/16" Wrench but do not tighten yet.
3. Align the Hole in the Tow Beam with the Hole in the Front Frame Support and insert a 5/16-18 x 1" Bolt down through the Frame and Tow Beam (**Figure 5**). Secure with a 5/16" Flat Washer and a 5/16-18 Lock Nut but do not tighten yet.
4. Re-check the center of the Tow Beam on the Axle and tighten the two Lock Nuts on the U-Bolt (**Figure 6**).
5. Now tighten the 5/16-18 Lock Nut to secure the Front Frame Support to the Tow Beam with two 1/2" Wrenches (**Figure 5**).
6. Attach the Bent Hitch Plate to the Tow Beam with two 5/16-18 x 1" Bolts and two 5/16-18 Lock Nuts. Tighten with two 1/2" Wrenches.

Attaching the Chipper Hopper

Tool Needed:

- 1/2" Wrench

Tip: Insert a towel or large rag into the opening to keep the Bolts from falling into the Chipper. Position the Hopper as shown in Figure 7 with the Debris Guard hanging down

1. Attach the Chipper Hopper to the machine using four 5/16"-18 x 3/4" Carriage Bolts, four 5/16" Flat Washers and four 5/16"-18 Nylon Lock Nuts.

NOTE: Be sure to insert the Bolts, from the inside of the Chipper Hopper so that the threads are sticking out (**Figure 7**) and the heads are flush against the Hopper. Install the Bolts, Washers and Nuts one at a time.

2. Install a Flat Washer, then a Lock Nut on each Bolt. Initially install the Bolts and Nuts finger tight and then tighten the Nuts one turn using a 1/2" Wrench (**Figure 7**). Check to see that the Hopper is centered on the Inlet Chute and then tighten the Nuts securely.
3. If you used a towel or rag in the Chipper opening, remove it now.
4. With the help of another person, carefully roll the DR CHIPPER/SHREDDER from the Shipping Pallet, resting it on the front frame support.

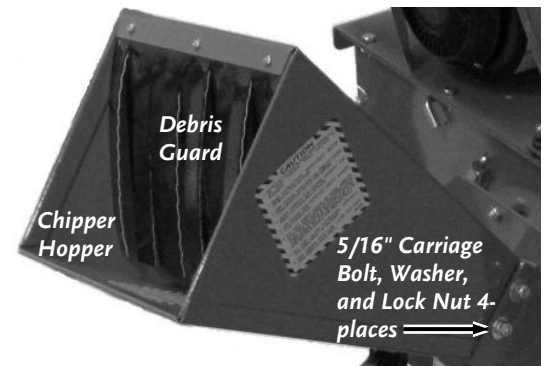

Figure 7

Adding Oil and Gasoline

NOTICE

- You **MUST** add oil before starting the Engine. This machine is shipped without oil. Traces of oil may be in the reservoir from factory testing, but you **MUST add oil before starting the Engine**. Fill the reservoir slowly, checking the level frequently to avoid overfilling.
- To get an accurate reading when checking the oil level:
 - The Engine **MUST** be level.
 - Refer to the Engine Manual for detailed information before performing the following procedures.

Engine Oil	SAE 30: above 50 degrees F; 10w-30: 10-90 degrees F; 5w-30: 30 degrees F or below
Fuel	Unleaded gasoline

Tools and Supplies Needed:

- Flat Head Screwdriver
- Small Funnel

NOTE: Use only the recommended high detergent Engine oil. Other types of oil could cause problems operating your machine. Please refer to your Engine Owner's Manual for more detailed oil information.

1. Block up the machine so the Engine is level. Remove the Oil Level Plug and the Oil Fill Plug with a Flat Head Screwdriver (**Figure 8**).
2. Put a small Funnel into the Oil Fill hole and initially add 16 oz. of the oil recommended by the Engine Manufacturer. Wait one minute for the oil to settle.
3. Check the Oil level at the Oil Level hole as described by the Engine Manual.
4. Continue adding a few ounces of oil at a time, rechecking the level until the oil reaches the full level as indicated in the Engine Manual. Be careful not to overfill.

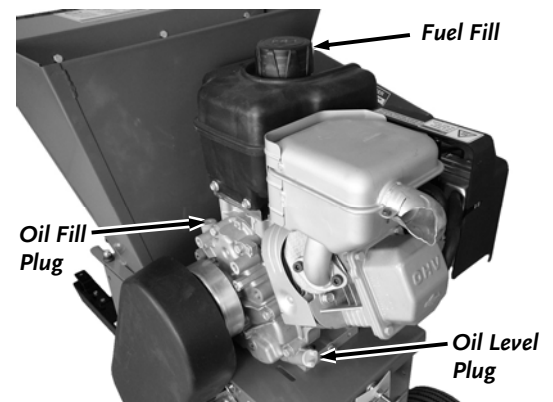

Figure 8

5. Replace the Oil Fill and Oil Level Plugs when full.
6. Remove the Fuel Fill Cap and fill the Fuel Tank with fresh, unleaded gas (with a minimum of 85 Octane) to approximately 1" to 1-1/2" below the top of the Fill Neck to allow for Fuel expansion (**Figure 8**). Be careful not to overfill and reinstall the Fuel Fill Cap before starting the Engine. See your Engine Owner's Manual for more detailed information.

NOTE: To refill the Fuel Tank, turn the Engine OFF, and let the Engine cool at least five minutes before removing the Fuel Fill Cap.

Check the Tire Pressure

Tools Needed:

- Tire Pressure Gauge
 - Air Compressor or Hand Pump
1. Remove the Valve Stem Protective Cap (**Figure 9**) and check the Tire pressure with a Tire Pressure Gauge.
 2. Check the manufacturers recommended pressure that is stamped on the side of the Tire.



Figure 9

! WARNING

Do not over inflate the Tires. Inflate to the manufacturers recommended pressure.

3. If the pressure is too low, add air through the Valve Stem with an Air Compressor or Hand Pump.
4. Replace the Valve Stem Protective Cap when finished.

Chapter 3: Operating The DR CHIPPER/SHREDDER

This chapter covers the procedures for starting and stopping your new DR CHIPPER/SHREDDER and discusses basic operation features. It may be helpful to better familiarize yourself with the features of your CHIPPER/SHREDDER by reviewing **Figure 1** in Chapter 2 before beginning the steps outlined in this chapter.

WARNING

Read and understand the warnings listed in “Chapter 1 General Safety Rules” before operating this CHIPPER/SHREDDER.

Starting the Engine

1. Check the Oil and Fuel level every time you use the DR CHIPPER/SHREDDER.
2. Turn the Fuel Shut-Off Valve to the OPEN position (**Figure 10**).
3. Check Inlet Hoppers and Discharge Chute and remove any debris buildup from the machine by first unplugging the Spark Plug Wire and following the instructions on page 16.
4. Move the Choke Control Lever to the right to the Choke position (leave in the Run position to the left if the Engine is already warm).
5. Move the Throttle to the right, FAST (Rabbit) position.
6. Grasp the Recoil Starter Handle and slowly pull until you feel resistance, then pull the cord rapidly to start the Engine. One or two pulls will usually start the DR CHIPPER/SHREDDER.
6. As the Engine warms up, slowly adjust the Choke to the left towards the Run position. Wait until the Engine runs smoothly before each Choke adjustment.
7. When the Engine is warmed up and running smoothly, ensure that the Choke is fully in the Run position to the left.

NOTE: The Throttle should always be fully to the right when Chipping/Shredding.

Stopping the Engine

Move the Throttle Control Lever all the way to the left past the SLOW (Turtle) position to the “STOP” position (**Figure 10**).

NOTE: Close the Fuel Shut-Off Valve when transporting or storing the DR CHIPPER/SHREDDER.

Before You Begin

- Visually check the Chipper Knife for damage each time you use the machine.

NOTE: Check for shaft movement while starting the Engine. If the shaft does not turn, STOP the Engine and clean out the Chipper/Shredder Hopper(s) as instructed on page 16.

- ALWAYS operate the DR CHIPPER/SHREDDER from the Operator Zones (**Figure 11**).
- When viewed from the Chipper Hopper side the Flywheel turns in a clockwise direction.
- NEVER assume you know where the Chipper Knife is. You do not know where it is.
- ALWAYS stop the Engine when leaving the Operating Zone or when moving the machine.

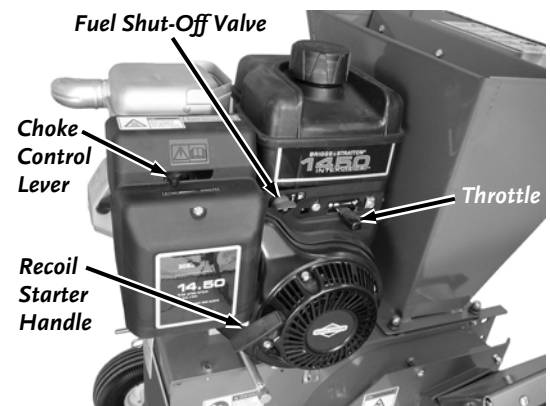

Figure 10

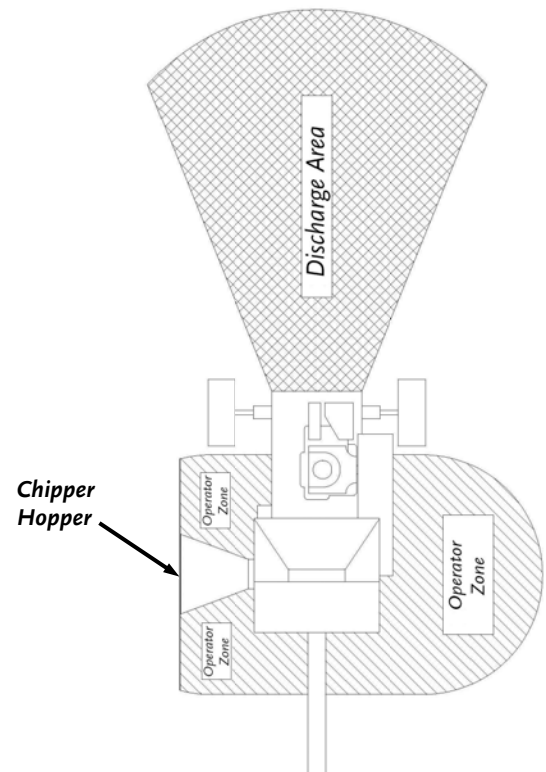

Figure 11

Processing Material

WARNING

Read and understand the warnings listed in “Chapter 1 General Safety Rules” before operating this CHIPPER/SHREDDER.

- Your DR CHIPPER/SHREDDER can process dry or green material.
- Green material will process quicker and easier than dry material.
- Soft wood processes easier than hard wood.
- Your operator experience will teach you how different materials chip/shred and how fast you can process different materials.
- Most materials process well with the standard screen provided with the DR CHIPPER/SHREDDER.
- It is best to trim off any side twigs from the main branch that you are chipping.
- When chipping branches, sometimes a tail will remain at the end of a branch. To avoid this, rotate the branch while feeding it into the Chipper Hopper. Rotating the branch as you feed it into the machine will improve chipping performance.
- Use caution with small diameter green saplings and branches less than 1" in diameter. Chip these grouped or bundled together to provide support for each other. If the material is 1" or larger, feed only one at a time into the Chipper Hopper.
- Make sure the DR CHIPPER/SHREDDER finishes processing material in the Hopper(s) before shutting the Engine off.

Using the Chipper Hopper

The Chipper Hopper is mounted on the side of the machine and is designed to chip the larger, heavier materials that the Shredder Hopper isn't designed to handle. The revolving Chipper Knife mounted on a flywheel turns branches fed into the Hopper into “chips”. The Chipper can chip twigs and branches ranging in size from 1" to 3" in diameter. Cut your materials into manageable lengths of no more than five or six feet long before feeding them into the Chipper Hopper.

WARNING

The Chipper Hopper must be securely bolted to the side of your DR CHIPPER/SHREDDER before using the machine!

- Feed the branch into Chipper Hopper keeping the branch at the same angle as the Chipper Hopper.
- As the branch becomes short and is at the outside edge of the Chipper Hopper, finish processing it by pushing it in with the next branch.
- Do not force material into the Chipper. If the machine does not chip well, the Chipper Knife may need sharpening or to be replaced, or the gap between the Knife and the Wear Plate needs adjusting. See page 21.
- Extremely hard knots will not process very well. Push any short stubs that have not self-fed through the Chipper, with the next branch to be chipped.

NOTICE

Never throw remaining stubs or knots into the Shredder Hopper; damage will result.

- Overloading the Chipper Hopper will cause the rotor speed to decrease. If you hear the Engine RPM decreasing, stop feeding material into the Chipper Hopper until the Engine has returned to full speed.
- NEVER allow processed material to build up within 3" of the Discharge opening. Move the DR CHIPPER/SHREDDER or the pile as needed. Failure to do so could result in unnecessary jamming of the machine.
- To move a pile of processed material, first shut off the Engine, and use a spade, rake, or long handle tool; NEVER use your hands or feet!

NOTICE

If you jam the machine and do not stop the Engine, it can damage the machine. This damage can be costly and not covered under warranty. See “To Free a Jammed Flywheel” on page 16.

Using the Shredder Hopper

The Shredder Hopper is located on the top of the DR CHIPPER/SHREDDER and is the opening into which all materials to be shredded should be fed. You can shred most organic materials. A flex guard, or blowback shield is attached to the Hopper. You must push material past this flap using a wooden stick in order to enter the main Shredding Chamber where revolving steel Hammers do the shredding.

CAUTION

The Blowback Shield is an important feature; it prevents kickback of materials! Do not use your machine unless the Blowback Shield is securely fastened in place.

- Due to the wide variety of materials that you can shred, and their very different physical characteristics, only feed limited quantities of any material into the Shredder Hopper at first. Increase the amount and length of material if you find that the material is processing without any difficulty. Your judgment and operator experience is very important. Be sure not to overload the machine by feeding too much material into the Hopper at one time. If you hear the speed of the Engine decreasing, stop feeding material into the machine at once. Do not resume feeding the machine until the Engine has returned to full speed.
- The maximum diameter of material that you can shred is 3/8". Feed any larger material through the Chipper Hopper. Material larger than 3/8" can cause serious damage to any of the internal parts of the Shredding Chamber. Inspect the DR CHIPPER/SHREDDER after every use for bent Hammers, missing Spacers, clogging, or damage to the Screen or any other obvious problems. If damage occurs, the Rotor Assembly can become unbalanced causing excessive vibration. If used in this condition, damage can occur. Do not use the machine if vibration is present. Vibration is generally a warning sign of trouble.
- You can feed several small branches into the Shredder Hopper at once providing their combined diameter is less than 3/8". Cut branches longer than three (3) feet to make them more manageable. Allow green materials to dry, or process in small batches with dry materials to avoid winding around the Rotor Assembly.
- Wet materials will clog the machine easily. If clogging occurs, stop the Engine; remove the screen and process material without it. Processing in this way will reduce the amount of reduction, but will reduce clogging.

MATERIALS BEST SUITED FOR SHREDDING

MATERIALS BEST SUITED FOR SHREDDING			
Leaves	Flowers	Corn Stalks	Roots
Soil	Palm frond tops	Grass clippings	Garden debris
Potato vines	Straw and Hay	Hedge clippings	Tomato vines
Manure	Kitchen Waste	Small branches	

WARNING

The Hammers within the Shredding Chamber can tug suddenly at material fed into the Shredder Hopper. Do not hold on tightly to branches and vines, and do not feed material straight down into the Hopper with your arm pointing downward toward the opening. Instead, keep your arms parallel to the ground and several inches above the top edge of the Hopper.

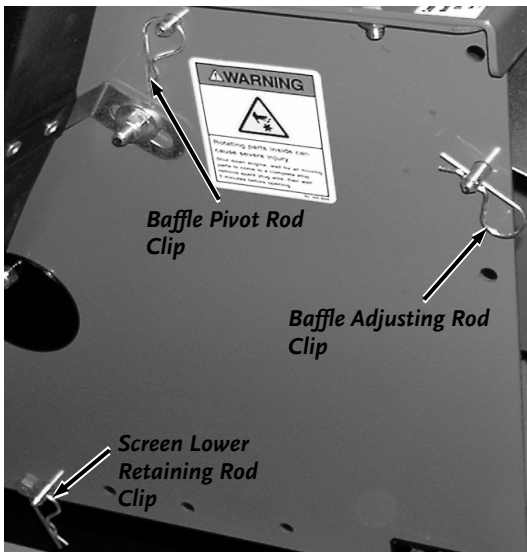

Figure 12

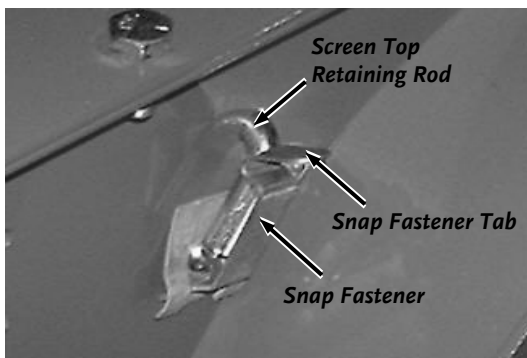

Figure 13

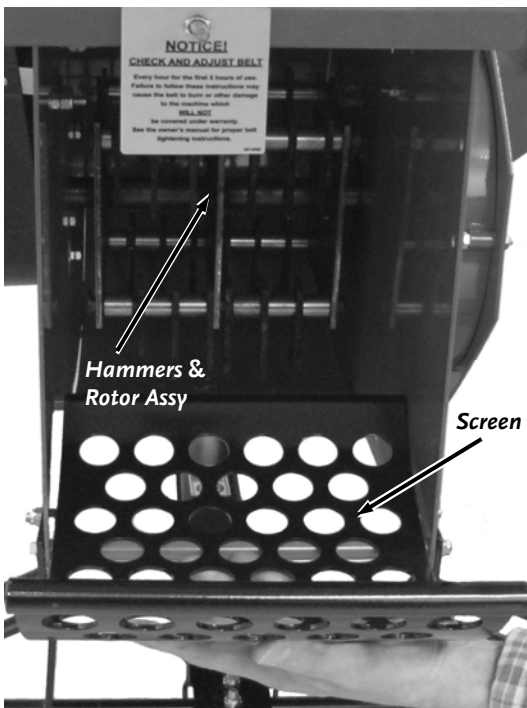

Figure 14

To Free a Jammed Flywheel

! WARNING

Before performing any maintenance procedure or inspection, stop the Engine, wait five (5) minutes to allow all moving parts to come to a complete stop and cool. Disconnect the Spark Plug Wire, keeping it away from the Spark Plug.

1. Remove any material left in the Chipper/Shredder Hopper.
2. Check the Discharge Opening for clogs. If it is clogged, clear it with a wooden stick.
3. Also, with a wooden stick, loosen and remove any material left in the Chipping/Shredding Chamber(s).
4. Start the machine and allow any remaining material in the Chipping/Shredding Chamber(s) to discharge.
5. If the Chipping/Shredding Chamber(s) does not clear and the Flywheel is still jammed, repeat the above process.
6. Be certain the Chipping/Shredding Chamber(s) is clear before trying to process more material into the Hopper(s), clogging could result in Belt or Clutch failure.

To Clean Out a Clogged Shredder

1. Remove the Baffle Plate by removing the Hair Spring Clip on the Adjusting Rod and the Pivot Rod and then removing the two (2) Rods (**Figure 12**).
2. Remove the Screen Top Retaining Rod (**Figure 13**) by first releasing the Snap Fastener by bending the Tab down.
3. Remove the Screen Lower Hair Spring Clip from the Retaining Rod and remove the Rod (**Figure 12**).
4. Now you can remove the Screen exposing the Shredder Hammers Assembly (**Figure 14**).
5. Remove any debris wrapped around the Shredder Hammers Drive Shaft or collected in the Hammers Assembly or Screen.
6. Reposition the Shredder Screen and reinstall the Top and Lower Screen Retaining Rods, Snap Fastener, and Hair Spring Clip.
7. Reposition the Baffle Plate and reinsert the Baffle Pivot Rod, Adjusting Rod, and the Hair Spring Clips.
8. Reconnect the Spark Plug wire, start the machine, and allow any remaining material in the Shredding Chamber to discharge.
9. If the Shredding Chamber does not clear, repeat the above process.

NOTICE

Be certain the Shredding Chamber is clear before trying to process more material into the Hopper, clogging could result in Belt or Clutch failure.

Chapter 4: Maintaining The DR CHIPPER/SHREDDER

Regular maintenance is the way to ensure the best performance and long life of your machine. Please refer to this manual and the Engine Manufacturer's Owner's Manual for maintenance procedures. Service intervals listed in the checklist below supersede those listed in the Engine Manufacturer's Owner's Manual.

WARNING

Before performing any maintenance procedure or inspection, stop the Engine, wait five (5) minutes to allow all parts to cool. Disconnect the Spark Plug Wire, keeping it away from the Spark Plug.

Regular Maintenance Checklist

PROCEDURE	BEFORE EACH USE	EVERY 8-10 HOURS	EVERY 40 HOURS	EVERY 100 HOURS
Check Engine Oil Level	▲			
Check General Equipment Condition	▲			
Check that the Shaft turns freely	▲			
Clean Engine Exterior & Cooling Fins	▲			
Inspect Knife for damage	▲			
Check Knife and Wear Plate for Sharpness		▲		
Check Knife and Wear Plate Attachment Screws		▲		
Check Knife to Wear Plate Gap		▲		
Check Rotor Hammers/Spacers for Wear		▲		
Check Side Bearing Collar Set Screws		▲		
Lubricate Side Bearings		▲		
Check Belt Tension and Condition	Break in period - once every hour for first 5hrs	▲		
Clean Air Filter		▲		
Replace Air Filter			▲	
Check Tire Pressure			▲	
Change Engine Oil	1 st time 5 hrs		▲	
Replace Drive Belt and Spark Plug				▲
Reverse Rotor Hammers				▲

Removing and Replacing the Engine Oil

Tools and Supplies Needed:

- 5/8" Wrench
- Rags and approved Container (for waste oil)
- Small funnel
- Engine Oil (see your Engine Manual for Oil specifications)

NOTE: Drain the oil when the Engine is warm; warm oil drains quickly and completely.

1. Level the Tow Beam, remove the Oil Fill/Dipstick, (**Figure 1** on page 8) and using a 5/8" Wrench, remove the Oil Drain Cap (**Figure 8** on page 11) allowing the used oil to drain completely into a Waste Oil Container.
2. Replace the Oil Drain Plug, and refill with new oil (see "**Adding Oil and Gasoline**" on page 11).

NOTE: Be sure to use environmentally safe disposal procedures in the disposing of the used oil.

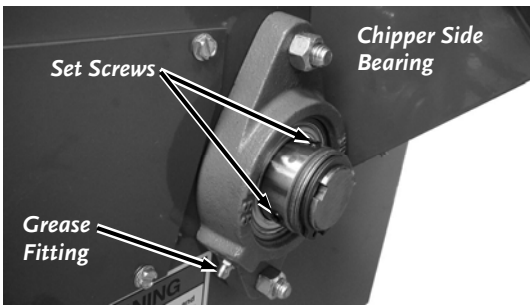

Figure 15

Grease Fittings

Your DR CHIPPER/SHREDDER was greased at the Factory. The operator needs to lubricate the Chipper Side and Drive Side Bearings periodically.

Tools and Supplies Needed:

- Flexible hose grease gun
- Lithium grease
- Clean cloth
- 5/32" Allen Wrench
- Loctite® 243 (if needed)

1. Wipe all dirt, etc., from the Grease Fitting(s) with a clean cloth (**Figure 15**).
2. Apply no more than three pumps of quality general-purpose lithium grease with a hand-pumped grease gun to each Grease Fitting, one on the Chipper Side Bearing, and one on the Drive Side Bearing (not shown). To access the Drive Side Bearing, you will have to remove the Belt Guard (see below).

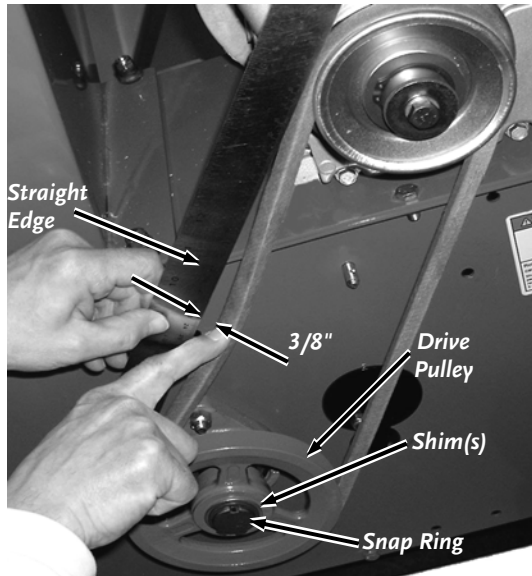

Figure 16

NOTICE

Over lubrication can damage Bearings.

3. After greasing, check the Side Bearing Collar Set Screws (**Figure 15**) for tightness with a 5/32" Allen Wrench. There are two Set Screws per Bearing. If they are loose, reset them with Loctite® 243, obtainable at most hardware stores.

Adjusting or Removing and Replacing the Drive Belt

NOTICE

Use only a DR Belt on your machine. The Belt has been thoroughly tested and proven for many hours of use.

Tools and Supplies Needed:

- (2) 1/2" Wrench
- 5/32" Allen Wrench and Snap Ring Pliers (if needed)
- Loctite® 243 (if needed)
- Straight Edge

1. Remove the Belt Guard by removing the retaining Nuts, Washers, and Bolts using two 1/2" Wrenches. Note the placement of Flat Washers for re-assembly.
2. The Belt should deflect 3/8" under approximately three pounds of pressure as shown in **Figure 16**, if it doesn't, adjust per the following directions.
3. Remove the Baffle Plate (see **Figure 12** on page 16).
4. Loosen the four Engine Bolts (2 in the Front and 2 in the Rear) using two 1/2" Wrenches (**Figure 17** on page 19).
5. Use a 1/2" Wrench to back off the Tag Nut from the Adjust Nut (**Figure 18** on page 19).

NOTE: If you are replacing the Belt, turn the Adjust Nut out as needed to create enough slack so you can remove the Belt. Install the new Belt and continue to the next step.

6. Use a 1/2" Wrench to turn the Adjust Nut in to tighten or out to loosen for the correct Belt deflection (**Figure 16**).

7. After adjustment is complete retighten the Tag Nut.
8. Retighten the Engine Bolts.
9. Check the alignment of the Clutch with the Drive Pulley by placing a Straight Edge across the face of the Drive Pulley (**Figure 19**). The Straight Edge should be parallel with the Belt. If adjustment is necessary, correct the alignment as follows:
 - a) Remove the two Set Screws in the Drive Pulley Hub with a 5/32" Allen Wrench and set them aside.
 - b) Using a Straight Edge, align the Drive Pulley (**Figure 19**) to be parallel with the Belt, by moving the Drive Pulley in or out on the Rotor Shaft (**Figure 16** on page 18).

NOTE: If the Drive Pulley cannot be moved in or out enough to obtain parallelism, you will have to swap the shims behind or in front of the Drive Pulley. This will necessitate removing the Belt and the Snap Ring on the Rotor Shaft (**Figure 16** on page 18), swapping the shims and reinstalling the Drive Pulley, Snap Ring and Belt. Once you have obtained parallelism, continue with step c).

- c) Apply Loctite® 243 to the threads of the Set Screws and reinsert them into the Drive Pulley Hub.
- d) Tighten the Set Screws while maintaining the parallelism between the Drive Pulley face and the Belt.
- e) Recheck the alignment after tightening the Set Screws.

10. Reinstall the Belt Guard.

NOTE: Check and re-tighten the Drive Belt, if necessary, after an initial break-in period of one (1) hour.

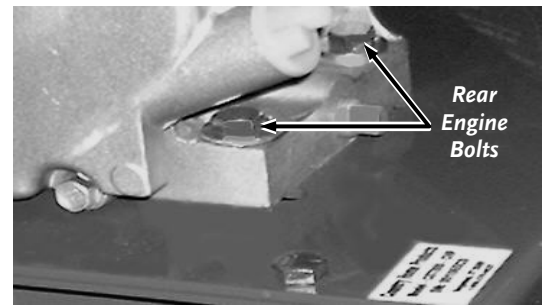

Figure 17

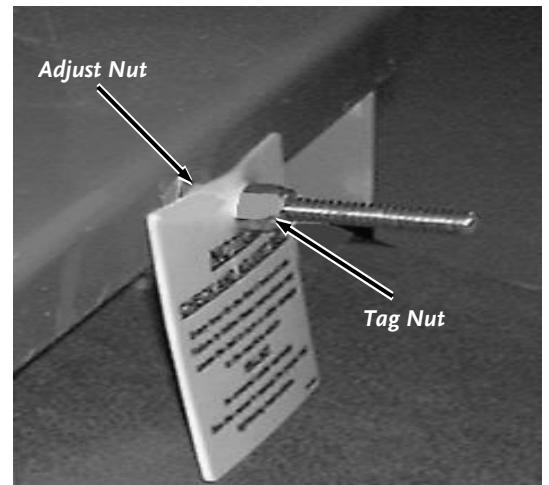

Figure 18

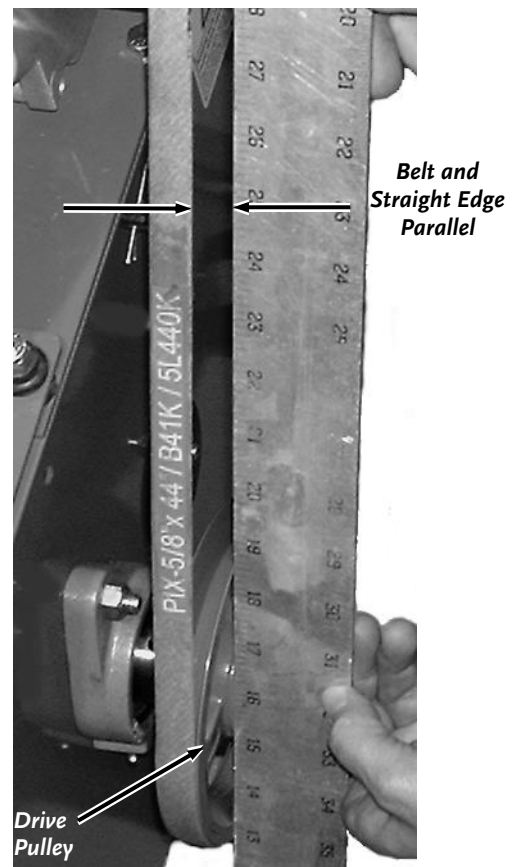
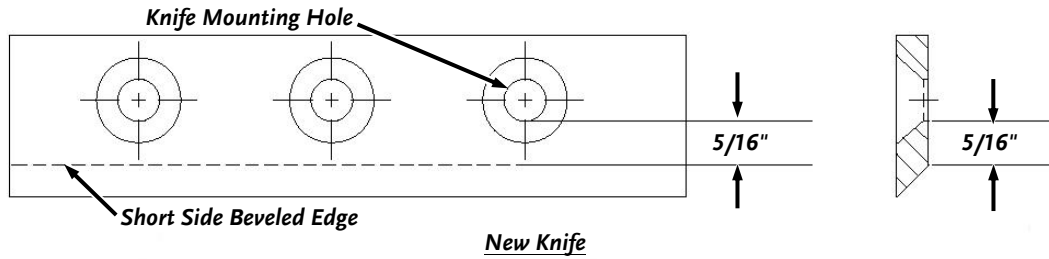

Figure 19

Knife Sharpening

- You should never attempt to sharpen the Chipper Knife freehand; take the Knife to a machine shop for proper sharpening.
- It is extremely important to consistently maintain the 45-degree angle for proper performance.
- Excessive heat generated during the sharpening process will damage Knives and weaken the metal.
- How many times a Knife can be sharpened is determined by how much material needs to be taken off to sharpen or to compensate for dents or gouges.
- A new Chipper Knife has a 5/16" measurement between the short side bevel edge and the Knife mounting holes (**Figure 20**).



New Knife

Figure 20

- The knife should never be sharpened to the extent that more than 3/32" is taken off this measurement.
- Once this measurement is below 7/32" (**Figure 21**), or if you are unable to remove dents or gouges with these guidelines, replace the Knife.

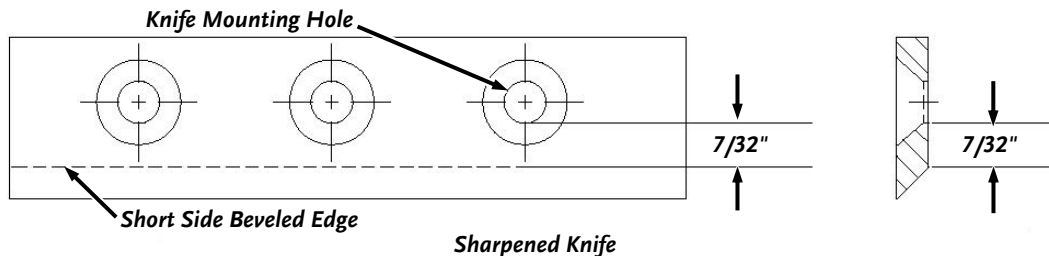

Sharpened Knife

Figure 21

Removing and Replacing the Chipper Knife

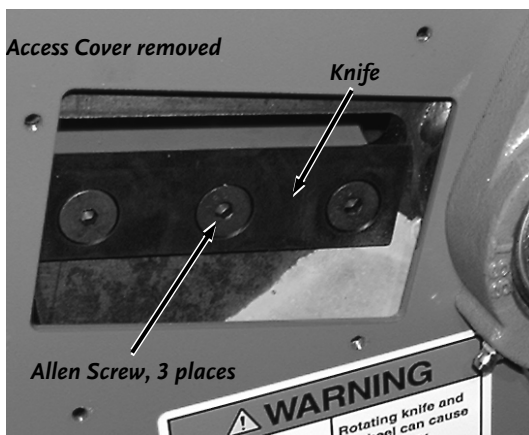

Figure 22

Tools and Supplies needed:

- 5/16" Wrench
- 3/16" Allen Wrench
- Awl
- Propane Torch
- Gloves
- Loctite® 243

1. Using a 5/16" Wrench, remove the Access Cover (**Figure 22**) on the Chipper Side.
2. Rotate the Chipper Disk using a stick until the three countersunk Allen Screws attaching the Knife to the Flywheel are visible through the Access Opening.
3. Clean out the heads of the Allen Screws with an awl or sharp tool.
4. Insert a 3/16" Allen wrench into the head of a screw.

- While applying a counterclockwise force with the Allen Wrench, apply heat from a propane torch to the Screw to break loose the Loctite® securing the screw.

NOTE: Remove the heat once the Screw has loosened and remove the Screw.

Tip: You may have to block the Flywheel in place while loosening the Screws (**Figure 23**).

- Repeat Steps 4 and 5 for the remaining two Allen Screws.
- Remove the dull or damaged Knife and visually inspect the Chipper Disk Slot and Knife mounting area and be sure they are clean. Metal burrs may need filing so that the replacement Knife will be able to mount flush against the Chipper Disk.
- Apply Loctite® 243 to the three new Allen Screws supplied with a new Knife or to the original screws if replacing with a sharpened Knife.
- Install a new or sharpened Knife and finger tighten the Allen Screws to hold the Knife to the Chipper Disk.
- Using a 3/16" Allen Wrench, tighten the center Screw, then tighten the outer Screw, and finally tighten the inner Screw.
- Double-check all three Screws for tightness one more time.
- Reinstall the Access Cover.
- Check the gap between the Knife and Wear Plate and adjust if required.

Check and Adjusting the Knife to Wear Plate Gap

When you replace the Knife, check and set the clearance between the Knife and Wear Plate. Set this clearance or gap to 1/16" (**Figure 24**). If the gap between the Wear Plate and the Knife is not set correctly, you will have excessive vibration when chipping and the Knife will seem to be dull. The Wear Plate should have a square edge and be free of dents or gouges. The Wear Plate can be hand sharpened. Be careful not to overheat it during the sharpening process. This will change the characteristics of the steel and you will then have to replace the Wear Plate.

Tools Needed:

- 1/2" Wrench
- 7/16" Wrench
- Gap Gauge (provided with machine)

- Remove the Chipper Hopper by performing the steps on page 11 in the reverse order.
- Using a stick, rotate the Chipper Disk until the Knife is opposite the Wear Plate (**Figure 25**).
- Slide the Gap Gauge between the Knife and Wear Plate. If the gap is set correctly, the Gap Gauge will lightly touch both the Knife and Wear Plate. If the gap is too small, you will not be able to get the Gauge between the Knife and Wear Plate. If the gap is too large, there will be excess room between Gap Gauge, Knife, and Wear Plate.

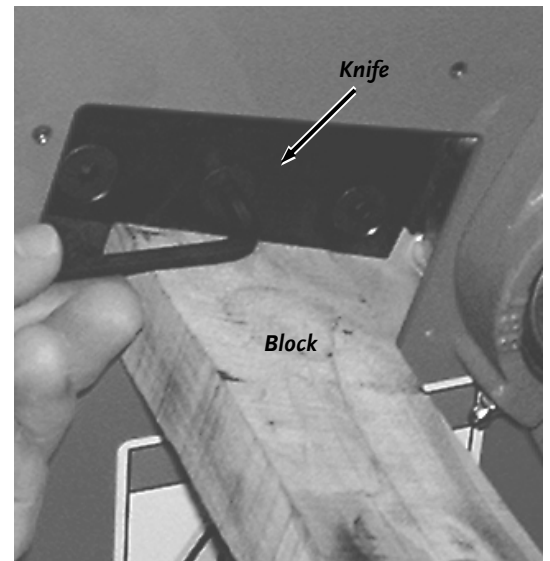

Figure 23

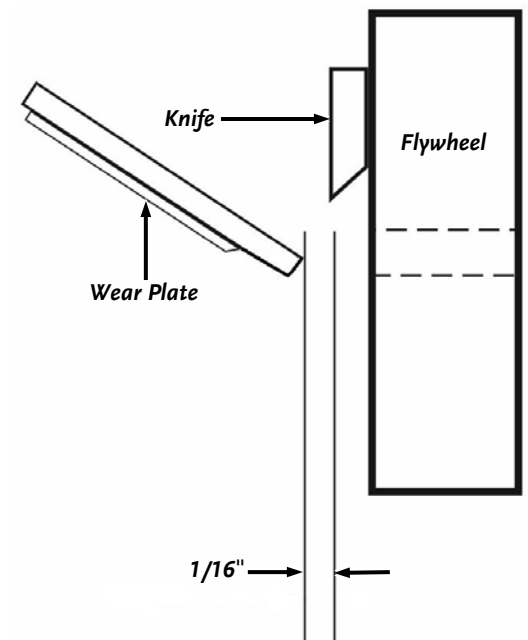

Figure 24

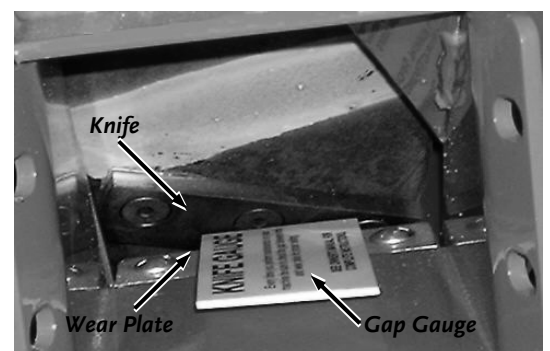

Figure 25

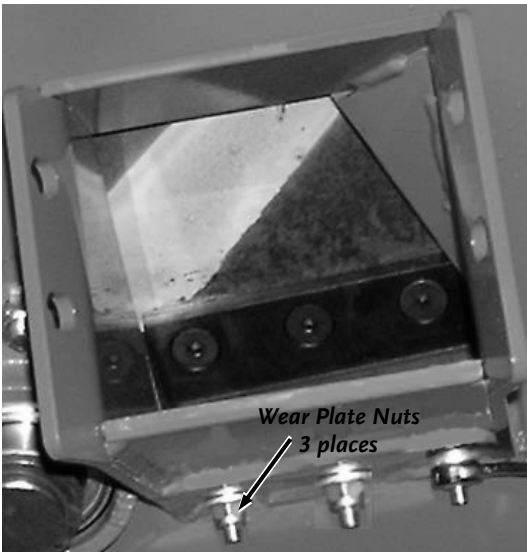

Figure 26

4. To adjust the Wear Plate Gap, loosen the three 1/4" Nuts using a 7/16" Wrench (**Figure 26**). Now slide the Wear Plate up or down (in or out) to achieve the correct gap setting.
5. Tighten the Nuts when the Wear Plate is at the correct distance from the Knife (**Figure 24** on page 21).
6. Replace the Chipper Hopper.

NOTE: After any Knife or Wear Plate maintenance or adjustment, rotate the Chipper Disk watch and listen carefully for any unusual noises, clicking or vibration. If you detect any of these, inspect the machine for damage, or any loose parts. Repair or replace any damaged parts and tighten any loose parts before starting the DR Chipper/Shredder.

Adjusting the Shredder Hammers

When the hard steel Hammers of the Rotor Assembly become dull or round on the cutting edge, they may be rotated or reversed.

NOTE: The Hammers have four cutting edges that may be used before replacement is necessary. To reverse the Hammers, proceed as follows:

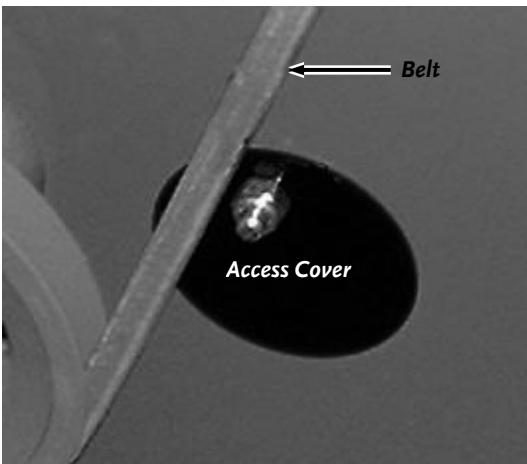

Figure 27

Tools and Part Required

- Two 1/2" Wrenches
- Hammer and Punch
- Four Grooved Pins, P/N 186180
- Vise Grips

1. Remove the Belt Guard (page 18) and the Baffle Plate (page 16).
2. Loosen the 5/16" Nut and rotate the round Access Cover Plate to expose the Access Hole (**Figure 27**).
3. Using two 1/2" Wrenches, remove the Shredder Hopper (**Figure 28**) by removing the four Bolts (hold the Nuts on top while backing out the Bolts) from the Vibration Dampers. Note that the Rear Bolts are 1-1/2" and the Front Bolts are 1-1/4" long. Lift the Hopper off with the Vibration Dampers in place (**Figure 28**).
4. Rotate the Hammer Rod until the Deep Grooved end of the Groove Pin at the end of the Rod is pointing down (**Figure 29** on page 23).
5. While holding the Hammer Rod in place with Vise Grips, drive out the Groove Pin with a punch (**Figure 29** on page 23).
6. Rotate the Hammer assembly until the Rod is lined up with the Access Hole.
7. Carefully remove the Rod through the Access Hole and at the same time remove the Hammers and spacers from the Rod leaving them in the same order as you removed them.
8. Now reverse each Hammer (end to end) by using the lower hole in the Hammer.

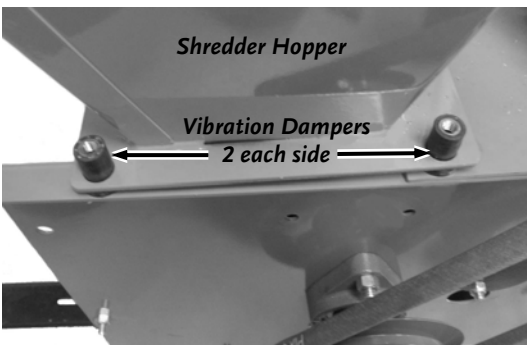

Figure 28

- Slide the Rod back through the Access Hole and reinstall the Hammers and Spacers in the same order as removed.

NOTE: Be sure you reinstall the Hammers and Spacers in exactly the same order that they were removed. Refer to the Rotor Assembly Schematic on page 29 for the correct order.

- Replace the old Groove Pin with a new one (deep grooves pointing up to install).
- Repeat steps 4 through 10 for the remaining three Hammer Rods.

Tip: To remember which Hammer Rod you have reworked, it may be helpful to mark the end of the Rods with a marker or tape.

- Reinstall the Shredder Hopper, Access Cover Plate, Belt Guard, and the Baffle Plate.

NOTE: When reinstalling the Shredder Hopper Bolts in the Vibration Dampers, remember that the shorter Bolts are in the Front and the Longer Bolts are in the Rear. Thread the Bolts up into the Dampers until one or two threads appear. Thread a Lock Nut onto each of the Bolts coming up through the Vibration Dampers. Hold the Nut and tighten the Bolt until one thread is completely through the front Nuts and about three threads showing through the Nuts in the rear. **DO NOT** over tighten the Bolts, as this will damage the Vibration Dampers and possibly lead to damage to your machine.

Removing and Replacing the Clutch

The design of the Clutch on your machine is for rugged, dependable service, however, it is important to understand the limitations of a Clutch. The Clutch design is to provide load free starting of the Engine, and slippage under excessive overloading of the driven application. These features help protect the Engine from damages such as broken crankshafts and starters. The Clutch on this machine is permanently lubricated and does not require oil or grease. The Drum, Shoes, and Springs in the Clutch are normal wear items. If, after long periods of use, the Drum wobbles excessively, or if you notice decreased performance of the Clutch, replace the Clutch.

The Clutch obtains its power from the Engine RPM. The lower the engagement speed, and the higher the maintained Engine speed, the more torque the Clutch can transfer to the driven unit. **NEVER operate the DR CHIPPER/SHREDDER Engine at less than full RPM.**

Tools and Supplies Needed:

- Two 1/2" Wrenches
- 9/16" Wrench
- Anti-seize compound

- Remove the Baffle Plate (page 16), the Belt Guard (page 18), loosen the Engine Bolts (page 18), and remove the Belt (page 18) and set it aside.
- Remove the Clutch from the Engine Crankshaft by removing the Clutch Bolt and Washer and then slide the Clutch Assembly from the Crankshaft (**Figure 30**) (any Spacers remain on the Crankshaft).

Tip: Hold the Hub with Vise Grips while loosening the Clutch Bolt.

- Remove the Key from the Keyway in the Engine Crankshaft and set it aside.
- Clean the Engine Crankshaft and remove any burrs, then apply anti-seize compound to the Crankshaft.
- Install the Key in the Keyway of the Engine Crankshaft, align the Key with the slot in the new Clutch Hub, and then slide the new Clutch Assembly onto the Crankshaft followed by the Washer and Clutch Bolt. Tighten the Bolt securely.
- Reinstall the Drive Belt and set the Belt tension and alignment (page 18).
- Reinstall the Belt Guard and Baffle Plate.

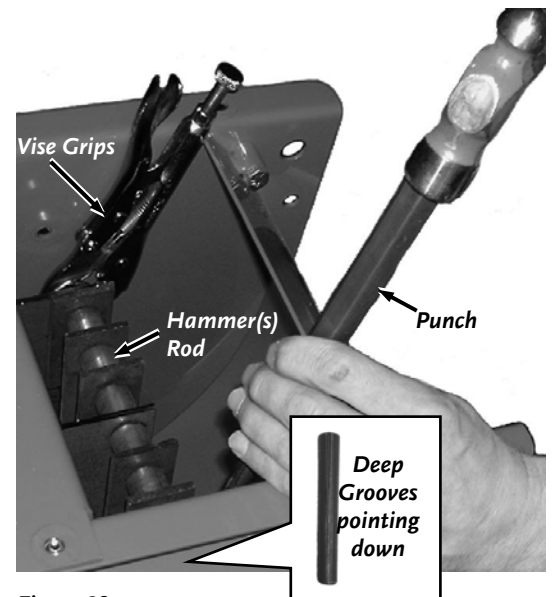

Figure 29



Figure 30

Chapter 5: Troubleshooting

Most problems are easy to fix. Consult the Troubleshooting Table below for common problems and their solutions. If you continue to experience problems, contact us at www.DRpower.com or call toll-free 1-800-DR-OWNER (376-9637) for support.

WARNING

Shut down the Engine, remove the Spark Plug Wire, and wait 5 minutes before performing any maintenance procedure or inspection on the Chipper/Shredder.

Troubleshooting Table

SYMPTOM	POSSIBLE CAUSE
<p><i>Recoil will not pull out or is difficult to pull.</i></p>	<ul style="list-style-type: none"> ⇒ Remove any built-up debris from the Chipper/Shredder Hopper Inlet(s) and Discharge Chute. ⇒ There may be an oil compression lock in the cylinder. Take out the Spark Plug; hold a rag over the Spark Plug hole and pull the Recoil Cord several times to blow out any oil in the Cylinder. Wipe off the Spark Plug and reinstall it. ⇒ Check the Engine oil level; the Engine may be seized. ⇒ The Recoil may be broken or jammed. Visit our website at www.DRpower.com.
<p><i>The Engine will not start.</i></p> <p><i>(Please refer to the Engine Owner's Manual for Engine-specific procedures.)</i></p>	<ul style="list-style-type: none"> ⇒ Check the oil and gas level. ⇒ Make sure that the Fuel Shut-Off is in the ON position. ⇒ Check that the Spark Plug Wire is attached. ⇒ The Air Filter may be dirty; change it following the procedure in the Engine Owner's Manual. ⇒ The gas may be old; change it if necessary. Use a fuel stabilizer if you keep gas longer than one month. ⇒ Check the Throttle and Choke settings, adjustment and travel. ⇒ The Spark Plug may be dirty or cracked; change it if necessary. If it's oily, leave it out, hold a rag over the Plug Hole and pull the Recoil Cord several times to blow out any oil in the Cylinder, then wipe off the Plug and reinsert it. ⇒ If your Engine still won't start, visit our website at www.DRpower.com.
<p><i>The Engine lacks power or is not running smoothly.</i></p> <p><i>(Please refer to the Engine Owner's Manual for engine-specific procedures.)</i></p>	<ul style="list-style-type: none"> ⇒ Make sure the Choke Lever is all the way to the RUN position (left). ⇒ Make sure that the Throttle Lever is all the way to the right (FAST- Rabbit). ⇒ The Air Filter may be dirty; change it following the procedure in the Engine Owner's Manual. ⇒ The Spark Plug may be dirty or cracked; change it if necessary. If it's oily, leave it out, hold a rag over the Plug Hole and pull the Recoil Cord several times to blow out any oil in the Cylinder, then wipe off the Plug and reinsert it. ⇒ The gas may be old; change it if necessary. Use a fuel stabilizer if you keep gas longer than one month. ⇒ The Engine oil may be dirty. Change it if necessary. ⇒ Check that the Cooling Fins are clean and free of debris. Clean as needed. ⇒ If your Engine still lacks power, visit our website at www.DRpower.com.
<p><i>Engine smokes.</i></p> <p><i>(Please refer to the Engine Owner's Manual for engine-specific procedures.)</i></p>	<ul style="list-style-type: none"> ⇒ Check the oil level and adjust as needed. ⇒ You may be operating the machine on too great an incline. The machine should be level. ⇒ The Air Filter may be dirty; change it following the procedure in the Engine Owner's Manual. ⇒ You may be using the wrong oil - too light for the temperature. Refer to your Engine Owner's Manual for detailed information. ⇒ Check that the Cooling Fins are clean and free of debris. Clean as needed. ⇒ If your Engine still smokes, visit our website at www.DRpower.com.

Troubleshooting Table (Continued)

WARNING

Shut down the Engine, remove the Spark Plug Wire, and wait 5 minutes before performing any maintenance procedure or inspection on the Chipper/Shredder.

SYMPTOM	POSSIBLE CAUSE
<i>The Engine runs but the Flywheel doesn't rotate.</i>	<ul style="list-style-type: none"> ⇒ The Throttle Lever should be in the FAST (Rabbit) position to engage the Clutch. ⇒ The Drive Belt is loose, off or broken. Reinstall, re-tension, or change Belt (refer to "Chapter 4: Maintaining the DR Chipper/Shredder"). ⇒ Remove any built-up debris from the Chipper/Shredder Hopper Inlet(s) and Discharge Chute. ⇒ The inner Shoes of the Clutch are worn and/or the Clutch Shoe Retaining Springs are weak or broken. Change the Clutch (refer to "Chapter 4: Maintaining the DR Chipper/Shredder").
<i>Shredding and chipping action seems too slow or flywheel stalling.</i>	<ul style="list-style-type: none"> ⇒ The Engine speed is too slow causing the Belt to slip. Run the Engine at full throttle (Rabbit). ⇒ Check for loose or damaged Drive Belt; tighten or replace. ⇒ Check for a dull or damaged Knife; sharpen or replace the Knife. Check for a clogged Shredder Screen, clean if necessary.
<i>Belt frays or falls off frequently.</i>	<ul style="list-style-type: none"> ⇒ The Drive Pulley or Clutch groove may be nicked. Check the Drive Belt for wear and hard spots. File off any nicks on the Drive Pulley or Clutch. ⇒ The Drive Belt may be stretched; readjust or replace it.
<ul style="list-style-type: none"> - Clutch overheats. - Belt burns. - Flywheel won't turn. 	<ul style="list-style-type: none"> ⇒ Immediately stop the Engine and remove the Spark Plug Wire. ⇒ Turn the Flywheel with a wooden stick to be sure it turns freely. ⇒ Check the Drive Belt tension. ⇒ Remove any built-up debris from the Chipper/Shredder Hopper Inlet(s) and Discharge Chute.
<i>The machine has excessive vibration.</i>	<ul style="list-style-type: none"> ⇒ Check for a dull or damaged Knife; sharpen or replace the Knife. ⇒ The Rotor is out of balance. Check the Rotor Assembly for any missing or broken Hammers or Spacers; replace if necessary. ⇒ The Knife may not be seated properly on the Flywheel. Loosen the Knife mounting screws, reset the Knife, and tighten the screws. Also, check the Knife to Wear Plate Gap. ⇒ If your machine still exhibits excessive vibration, visit our website at www.DRpower.com.
<i>When chipping, the log seems to vibrate excessively and "hammers" my hands.</i>	<ul style="list-style-type: none"> ⇒ The Knife is dull; sharpen or replace it. ⇒ The gap between the Knife and Wear Plate is too great; adjust the Gap.
<i>Chipper Knife is hitting the Wear Plate.</i>	<ul style="list-style-type: none"> ⇒ The gap between the Knife and the Wear Plate is set incorrectly; adjust the Knife to Wear Plate Gap.
<i>The machine's wheels track left or right while being towed.</i>	<ul style="list-style-type: none"> ⇒ Check the tire pressure and set to the recommended pressure stamped on the side of the tire. ⇒ Check that the Tow Bar is centered on the axle; adjust as required.

Chapter 6: Parts Lists and Schematic Diagrams

Parts List – DR CHIPPER/SHREDDER ASSEMBLY – CHIPPER SIDE and DRIVE SIDE

NOTE: Part numbers listed are available through DR Power Equipment.

Ref#	Part#	Description	Ref#	Part#	Description
01	292541	Weldment, Shredder Hopper	32	N/A	CHIPPER/SHREDDER BASIC ASSY
02	157301	Bolt, HHCS, 1/4"-20 x 3/4"	33	154481	Nut, Nylon Lock, 3/8"-16
03	293430	Guard, Flex	34	292621	Brace, Front Support
04	310521	Engine, B&S 1450 Series	35	146051	Bolt, HHCS, 5/16"-18 x 1", GR5
05	145170	Bolt, HHCS, 5/16"-18 x 2"	36	292631	Bolt, HHCS, 3/8"-16 x 1", GR5
06	154181	Tensioner, Belt	37	148551	Key, Shaft, 1/4" Square x 1-1/2"
07	145151	Washer, Flat, 5/16", USS	38	142311	Pulley, Flywheel Shaft, 6"
08	143131	Nut, Nylon Lock, 5/16"-18	39	292641	Spacer, 1-3/4"
09	288721	Screen, 1" Diameter Holes	40	158531	Spacer, Wheel, 5/8"
10	292571	Plate, Baffle	41	186131	Nut, Gripco, 5/16"-18
11	185861	Bracket, Axle	42	293391	Belt, 5H440
12	167791	Bolt, HHCS, 5/16"-18 x 3/4"	43	185941	Plate, Cover
13	143401	Nut, Nylon Lock, 1/4"-20	44	292651	Guard, Belt, Assembly – Black
14	149340	U-Bolt, 1/4"-20 x 1-1/4"	45	144451	Bolt, HHCS, 3/8"-24 x 1-1/4", GR 8
15	169731	Axle, 28-1/4"	46	216511	Washer, Lock, Split, 3/8"
16	154651	Tire/Wheel, 4.10/3.50 x 4	47	162081	Washer
17	154881	Cap, Push	48	140751	Clutch
18	292581	Cap Screw, HHCS, 5/16"-18 x 10"	49	183221	Spacer/Shim, Clutch
19	291291	Rod, Screen and Baffle	50	294061	Pipe, Oil Drain, 1/4" NPT x 6" Galv.
20	292591	Fastener, Snap	51	294071	Cap, Pipe, Oil Drain, 1/4" NPT, ZP
21	292601	Bolt, HHCS, 5/16"-18 x 1-1/2", GR5	52	154801	Washer, Flat, 1/4", USS
22	186001	Damper, Vibration	53	152951	Ring, Retaining
23	143121	Bolt, HHCS, 5/16"-18 x 1-1/4", GR5	54	202800	Shim, 1.562" OD x 1.192" ID x .025" Thk
24	149261	Beam, Tow		155260	Shim, 1.562" OD x 1.192" ID x .050" Thk
25	142920	Plate, Bent, Tow Beam Hitch		202820	Shim, 1.562" OD x 1.192" ID x .075" Thk
26	208331	Shield, Blowback		202810	Shim, 1.562" OD x 1.192" ID x .125" Thk
27	202131	Screw, PHMS, 10-24 x 3/4", ZP	Available Accessories		
28	292611	Mount Strip, Blowback Shield,	288731		Screen, 1/4" Hole Diameter
29	202121	Nut, Nylon Lock, 10-24, ZP	288741		Screen, 1/2" Hole Diameter
30	202111	Hopper Kit, includes #26, 27, 28 & 29	288751		Screen, 3/4" Hole Diameter
31	145290	Bolt, Carriage, 5/16"-18 x 3/4"	288761		Screen, Oblong Stamped
			288771		Screen, Rectangular Stamped
			292661		Bagging Kit
			140051		Stand, Tow Beam
			140061		Pull Handle Kit

Schematic – DR CHIPPER/SHREDDER ASSEMBLY – CHIPPER SIDE

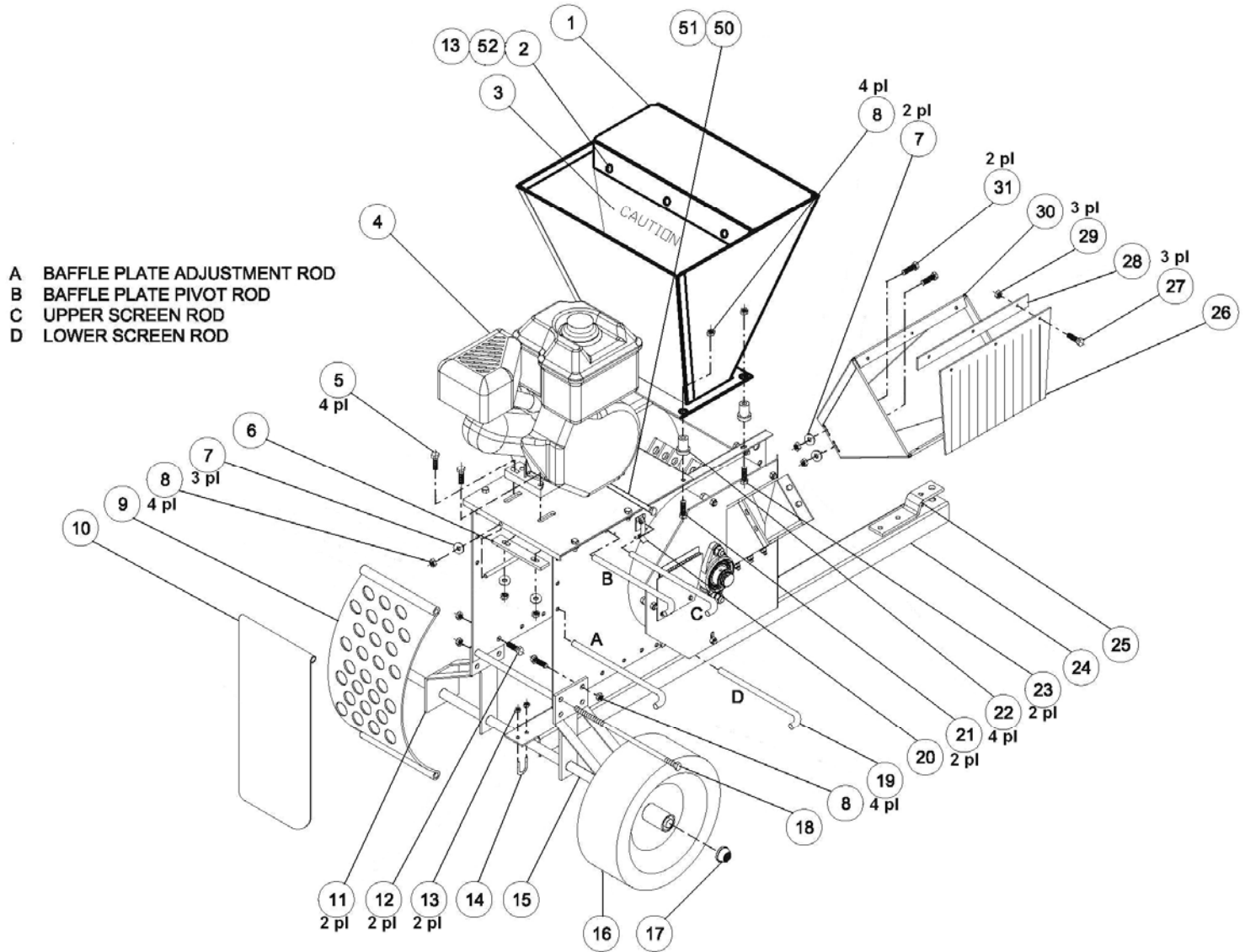

110401

Schematic – DR CHIPPER/SHREDDER ASSEMBLY – DRIVE SIDE

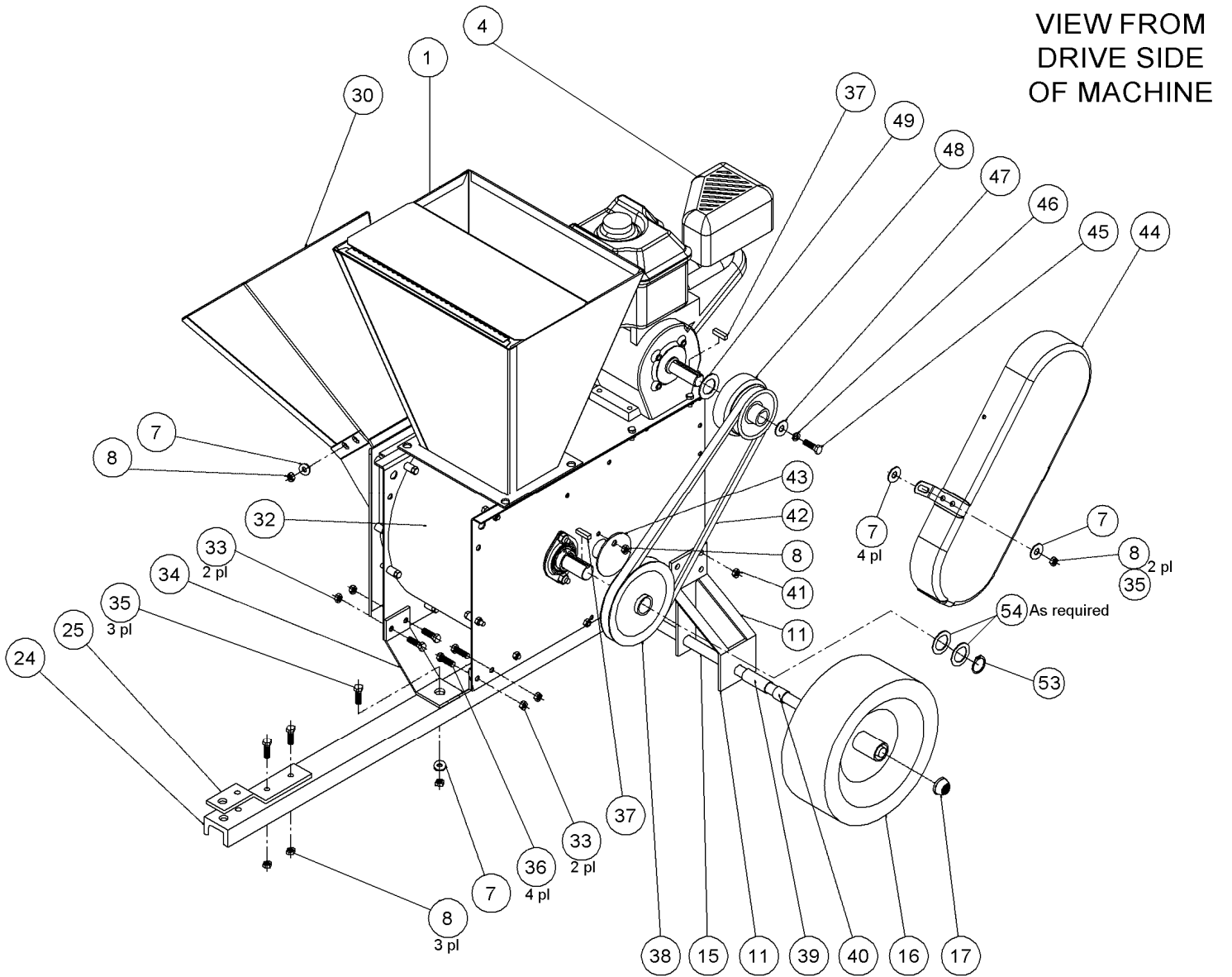

110403

Parts List and Schematic– DR CHIPPER/SHREDDER ROTOR ASSEMBLY

NOTE: Part numbers listed are available through DR Power Equipment.

Ref#	Part#	Description	Ref#	Part#	Description
01	292801	Weldment, Rotor	05	158531	Spacer, 5/8"
02	292811	Rod, Hammer	06	186171	Spacer, 7/8"
03	185790	Hammer	07	186171	Pin, Groove
04	186160	Spacer, 5/16"			

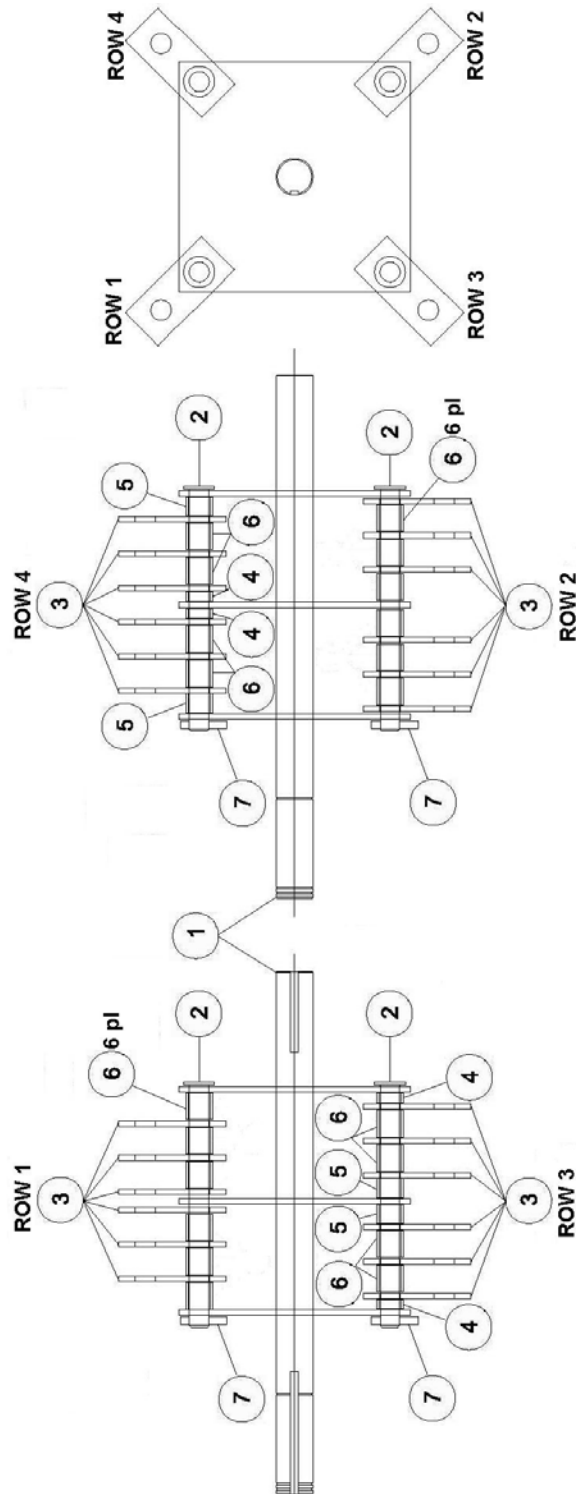

Parts List – DR CHIPPER/SHREDDER BASIC ASSEMBLY

NOTE: Part numbers listed are available through DR Power Equipment.

<u>Ref#</u>	<u>Part#</u>	<u>Description</u>	<u>Ref#</u>	<u>Part#</u>	<u>Description</u>
01	167791	Bolt, HHCS, 5/16"-18 x 3/4"	23	143390	Washer, Flat, 1/4", SAE
02	292681	Plate, Top	24	292741	Weldment, Chipper Plate & Chute
03	216391	Nut, Lock, Gripco, 3/8"-16	25	140681	Screw, FHSCS, 5/16-18 x 3/4"
04	186050	Bearing, Drive Side, 1-3/16"	26	292751	Knife
05	292701	Plate, Drive Side	27	292761	Disk, Chipper – includes Knife
06	154490	Bolt, HHCS, 3/8"-16 x 1-1/4"	28	183011	Ring, Retaining, SHR-118
07	186131	Nut, Gripco, 5/16"-18	29	292771	Weldment, Plate, Chipper Side
08	292711	Assembly, Rotor	30	292781	Weldment, Scroll
09	292721	Spacer	31	292281	Bolt, HHCS, 5/16"-18 x 1-1/2"
10	143121	Bolt, HHCS, 5/16"-18 x 1-1/4"			
11	292261	Bolt, HHCS, 5/16"-18 x 10"			
12	292731	Bolt, HHCS, 5/16"-18 x 9-1/2"			
13	202821	Shim			
14	185911	Screw, Set, 3/8"-16 x 5/8"			
15	140741	Bushing, Taper Lock			
16	195661	Bolt, Carriage, 1/4"-20 x 1"			
17	186041	Plate, Wear			
18	155121	Screw, Self Tapping, 10-32 x 3/8"			
19	292791	Door, Inspection			
20	152951	Ring, Retaining			
21	186051	Bearing, Chipper Side, 1-3/16"			
22	143401	Nut, Nylon Lock, 1/4"-20			

Schematic – DR CHIPPER/SHREDDER BASIC ASSEMBLY

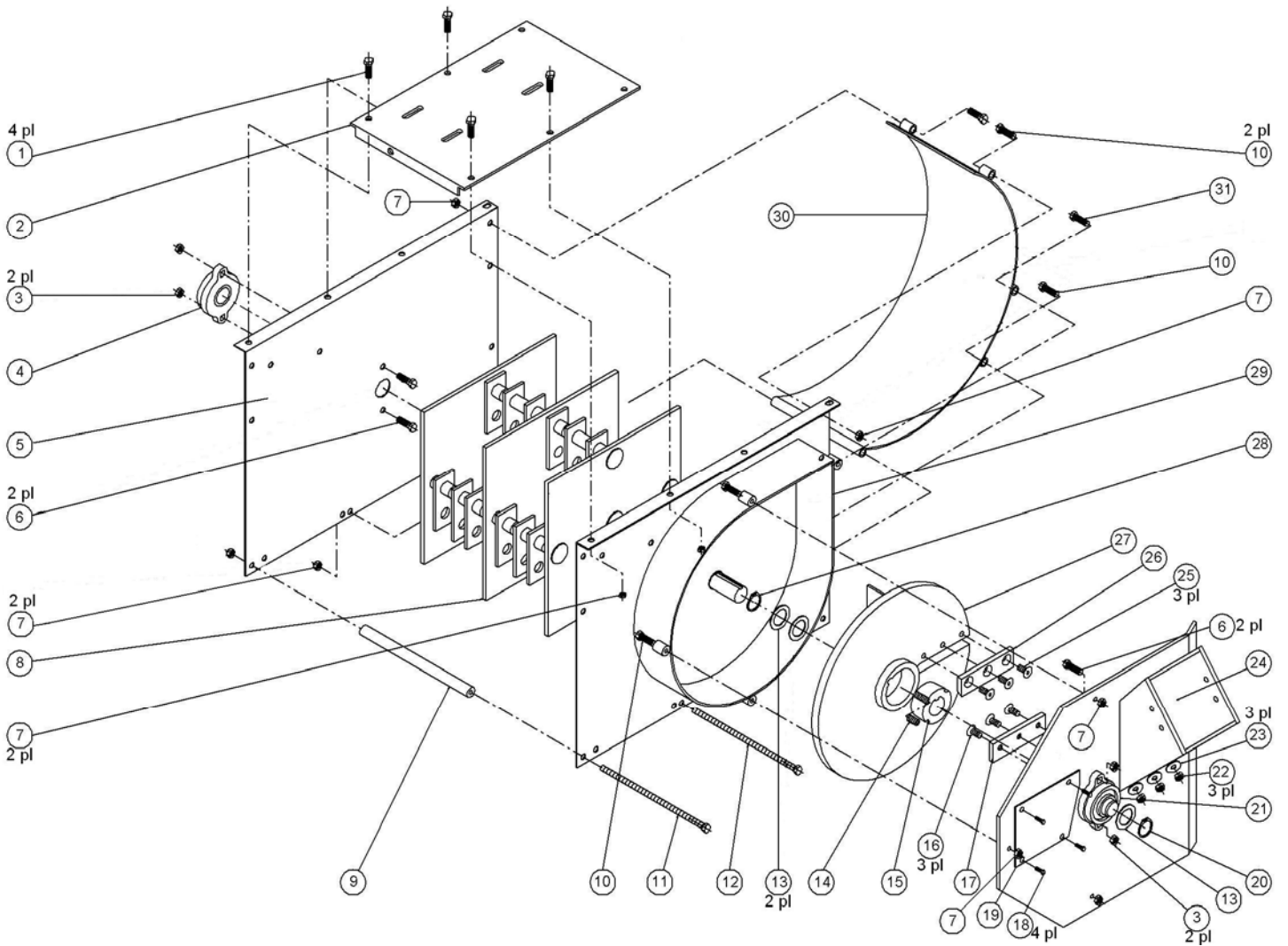

110404

Daily Checklist for the DR CHIPPER/SHREDDER

To help maintain your DR CHIPPER/SHREDDER for optimum performance, we recommend you follow this checklist each time you use your Chipper/Shredder.

! WARNING

Before performing any maintenance procedure or inspection, stop the Engine, wait five (5) minutes to allow all parts to cool. Disconnect the Spark Plug Wire, keeping it away from the Spark Plug.

- [] Check the Engine oil and Fuel Tank level.
- [] Check that Engine is clean of debris.
- [] Inspect the Chipper/Hopper(s) for accumulated debris.
- [] Check the general condition of the Chipper/Shredder, e.g.; nuts, bolts, welds, etc.
- [] Check Belt for wear and/or stretching.
- [] Check Tire Pressure and wear.
- [] Check the Chipper Knife for tightness, nicks and wear.
- [] Check the Wear Plate for tightness and nicks; the edge should be square.
- [] Check the Debris Guard for wear and damage.
- [] Remove any debris wrapped around the Hammer(s) Rotor.

End of Season and Storage

! WARNING

Before performing any maintenance procedure or inspection, stop the Engine, wait five (5) minutes to allow all parts to cool. Disconnect the Spark Plug Wire, keeping it away from the Spark Plug.

- Change the Engine oil.
- Clean or replace the Air Filter.
- Check the Chipper Knife, Hammers, and Wear Plate for nicks and wear.
- Remove any debris wrapped around the Hammer Rotor.
- If your DR CHIPPER/SHREDDER will be idle for more than 30 days, we recommend using a gas stabilizer. This will prevent sediment from gumming up the Carburetor. If there is dirt or moisture in the gas or tank, remove it by draining the tank. Completely fill the tank with fresh, unleaded gas and add the appropriate amount of stabilizer or gasoline additive. Run the Engine for a short time to allow the additive to circulate. Close the Fuel Shut-Off Valve to prevent carburetor overflow and leakage.
- Clean the exterior of the unit to remove all dirt, grease, and any other foreign material. To prevent rust, touch up painted surfaces that have been scratched or chipped.
- Be sure all nuts, bolts, and screws are securely fastened.
- Inspect moving parts and the Drive Belt for damage and wear; replace if necessary.
- Remove the Spark Plug and pour about 1 ounce of motor oil into the Cylinder hole. Replace the Plug and crank the Engine over a couple of times using the Pull Cord. This will coat the piston and seat the valves to prevent moisture buildup.
- If possible, store the Chipper/Shredder in a dry, protected place. If it is necessary to store the machine outside, after the DR CHIPPER/SHREDDER has cooled, cover the machine with a suitable protective cover that does not retain moisture. Do not use plastic as this material cannot breathe; it also allows condensation to form, which will cause your machine to rust.



75 MEIGS ROAD, P.O. BOX 25, VERGENNES, VERMONT 05491