

DR[®] SP22 MOWER

SAFETY & OPERATING INSTRUCTIONS



Serial No. _____

Order No. _____

Original Language

DR Power Equipment
Toll-free phone: 1-800-DR-OWNER (376-9637)
Fax: 1-802-877-1213
Website: www.DRpower.com

! WARNING

Read and understand this manual and all instructions before operating the DR SP22 MOWER.

Table of Contents

Chapter 1: General Safety Rules.....	3
Chapter 2: Setting Up The DR SP22 MOWER.....	7
Chapter 3: Operating The DR SP22 MOWER.....	12
Chapter 4: Maintaining The DR SP22 MOWER	15
Chapter 5: Troubleshooting	18
Chapter 6: Parts Lists, Schematic Diagrams And Warranty	19

Conventions used in this manual

DANGER

This indicates a hazardous situation, which, if not followed, ***will*** result in death or serious injury.

WARNING

This indicates a hazardous situation, which, if not avoided, ***could*** result in death or serious injury.

CAUTION

This indicates a hazardous situation, which, if not avoided, ***could*** result in minor or moderate injury.

NOTICE

This information is important in the proper use of your machine. Failure to follow this instruction could result in damage to your machine or property.

Serial Number and Order Number

A Serial Number is used to identify your machine and is located on the Serial Number Label on your machine. An Order Number is used to check and maintain your order history and is located on the upper left portion of your packing slip. For your convenience and ready reference, enter the Serial Number and Order Number in the space provided on the front cover of this manual.

Additional Information and Potential Changes

DR Power Equipment reserves the right to discontinue, change, and improve its products at any time without notice or obligation to the purchaser. The descriptions and specifications contained in this manual were in effect at printing. Equipment described within this manual may be optional. Some illustrations may not be applicable to your machine.

Chapter 1: General Safety Rules

WARNING

Read this safety & operating Instructions manual before you use the DR SP22 MOWER. Become familiar with the operation and service recommendations to ensure the best performance from your machine. If you have any questions or need assistance, please contact us at www.DRpower.com or call toll-free 1-800-DR-OWNER (376-9637) and one of our Technical Support Representatives will be happy to help you.

Labels

Your DR SP22 MOWER carries prominent labels as reminders for its proper and safe use. Shown below are copies of all the Safety and Information labels that appear on the equipment. Take a moment to study them and make a note of their location on your Mower as you set up and before you operate the unit. Replace damaged or missing safety and information labels immediately.

ONE-TOUCH HEIGHT ADJUSTMENT

322401

#32240



#136491



#32243



#32241

WARNING

AVOID SERIOUS INJURY OR DEATH

- Read the operator's manual before use.
- Do not mow when children and others are around.
- Look down and behind, before and while mowing backwards.
- Remove objects that could be thrown by the blade.
- Keep safety devices (guards, shields, switches, etc) in place and working.
- Use caution on slopes. Mow across slopes, not up and down.
- Wear safety goggles or glasses to protect eyes.

322421

#32242

Protecting Yourself and Those Around You

WARNING

This is a high-powered machine, with moving parts operating with high energy. You must operate the machine safely. Unsafe operation can create a number of hazards for you, as well as anyone else in the nearby area. Always take the following precautions when using this machine:

- Keep in mind that the operator or user is responsible for accidents or hazards occurring to other people, their property, and themselves.
 - Always wear protective goggles or safety glasses with side shields while using the Mower to protect your eyes from possible thrown debris.
 - Avoid wearing loose clothing or jewelry, which can catch on moving parts.
 - We recommend wearing gloves while using the Mower. Be sure your gloves fit properly and do not have loose cuffs or drawstrings.
 - Wear shoes with non-slip treads when using your Mower. If you have safety shoes, we recommend wearing them. Do not use the machine while barefoot or wearing open sandals.
 - Wear long pants while operating the Mower.
 - Use ear protectors or ear plugs rated for at least 20 dba to protect your hearing.
 - Keep bystanders at least 100 feet away from your work area at all times. Release the Blade Control Bar to stop the engine and the Blade when another person or pet approaches.
-

Safety for Children and Pets

WARNING

Tragic accidents can occur if the operator is not alert to the presence of children and pets. Children are often attracted to the machine and the mowing activity. *Never* assume that children will remain where you last saw them. Always follow these precautions:

- Keep children and pets at least 100 feet from the working area and ensure they are under the watchful care of a responsible adult.
 - Be alert and turn the machine off if children or pets enter the work area.
 - Never allow children to operate the Mower.
 - Use extra care when approaching blind corners, shrubs, trees, or other objects that may block your view of a child or pet.
-

Safety with Gasoline - Powered Machines

WARNING

Gasoline is a highly flammable liquid. Gasoline also gives off flammable vapor that can be easily ignited and cause a fire or explosion. Never overlook the hazards of gasoline. Always follow these precautions:

- Never run the engine in an enclosed area or without proper ventilation as the exhaust from the engine contains carbon monoxide, which is an odorless, tasteless, and deadly poisonous gas.
 - Store all fuel and oil in containers specifically designed and approved for this purpose and keep away from heat and open flame, and out of the reach of children.
 - Replace rubber fuel lines and grommets when worn or damaged and after 5 years of use.
 - Fill the gasoline tank outdoors with the engine off and allow the engine to cool completely. Don't handle gasoline if you or anyone nearby is smoking, or if you're near anything that could cause it to ignite or explode. Never overfill the tank and reinstall the fuel tank Cap and fuel container cap securely.
 - The engine exhaust from this product contains chemicals known to the State of California to cause cancer, birth defects, or other reproductive harm.
-

WARNING

- If you spill gasoline, do not attempt to start the engine. Move the machine away from the area of the spill and avoid creating any source of ignition until the gas vapors have dissipated. Wipe up any spilled fuel to prevent a fire hazard and properly dispose of the waste. If fuel is spilled on clothing, change clothing immediately.
- Allow the engine to cool completely before storing in any enclosure. Never store a machine that has gas in the tank, or a fuel container, near an open flame or spark such as a water heater, space heater, clothes dryer or furnace.
- Never make adjustments or repairs with the engine running. **Shut down the engine, disconnect the spark plug wire, keeping it away from the spark plug to prevent accidental starting, wait 5 minutes before making adjustments or repairs.**
- **Never tamper with the engine's governor setting. The governor controls the maximum safe operation speed and protects the engine. Over-speeding the engine is dangerous and will cause damage to the engine and to the other moving parts of the machine.**
- Keep combustible substances away from the engine when it is hot.
- Never cover the machine while the muffler is still hot.
- Do not operate the engine with the air cleaner or the carburetor air intake cover removed. Removal of such parts could create a fire hazard. Do not use flammable solutions to clean the air filter.
- The muffler and engine become very hot and can cause a severe burn; do not touch.
- Never fill containers inside a vehicle or on a truck or trailer bed with a plastic liner. Always place containers on the ground away from your vehicle before filling.
- Remove gas-powered equipment from the truck or trailer and refuel it on the ground. If this is not possible, then refuel such equipment with a portable container, rather than from a gasoline dispenser nozzle.
- Keep the nozzle in contact with the rim of the fuel tank or container opening at all times until fueling is complete. Do not use a nozzle lock- open device.

General Safety

WARNING

Operating this Mower safely is necessary to prevent or minimize the risk of death or serious injury. Unsafe operation can create a number of hazards for you. This Mower is capable of amputating hands and feet and throwing objects. Always take the following precautions when operating this Mower:

- Your Mower is a powerful tool, not a plaything. Exercise extreme caution at all times. The machine is designed to mow grass. Do not use it for any other purpose.
- Ensure that the Mower is located flat on a level and clean area of lawn before starting.
- Know how to stop the Mower quickly; see “stopping the engine” in chapter 3.
- Never operate your unit on a slippery, wet, muddy, or icy surface. Exercise caution to avoid slipping or falling.
- Always walk when mowing, never run.
- Stop the blade when crossing surfaces other than grass, and when transporting the lawnmower to and from the area to be mowed.
- See manufacturer's instructions for proper operation and installation of accessories. Only use accessories approved by DR Power Equipment.
- Never use the machine without ensuring that all guards and shields are in place.
- Never, under any conditions, remove, bend, cut, fit, weld, or otherwise alter standard parts on the Mower. This includes all shields and guards. Modifications to your machine could cause personal injuries and property damage and will void your warranty.
- Clear the area of objects such as rocks, wire, toys, etc., which could be thrown by the blade.
- Keep hands and feet clear of the discharge opening at all times and only operate the Mower from the operator position behind the handlebars.
- Allow only one person to operate the Mower at any time.
- Never direct discharged material toward anyone. Avoid discharging material against a wall or obstruction. Material may ricochet back toward the operator.
- Do not pull machine backward unless absolutely necessary. Always look down and behind before and while moving backward.

⚠ WARNING

- If the machine should start making an unusual noise or vibration, stop the engine, wait five minutes to allow all parts to cool. **Disconnect the spark plug wire, keeping it away from the spark plug, then inspect for damage. Vibration is generally a warning of trouble. Check for damaged parts and clean, repair and/or replace as necessary.**
 - **Never tamper with safety devices. Check their proper operation regularly.**
 - Before performing any maintenance procedure or inspection, stop the engine, wait five minutes to allow all parts to cool. **Disconnect the spark plug wire, keeping it away from the spark plug.**
 - Never allow people who are unfamiliar with these instructions to use the Mower. Allow only responsible individuals who are familiar with these rules of safe operation to use your machine.
 - Never overload or attempt to mow material beyond the manufacturer's recommendation. Personal injury or damage to the machine could result.
 - While using the Mower, don't hurry or take things for granted. When in doubt about the equipment or your surroundings, stop the machine and take the time to look things over.
 - **Never operate the machine when under the influence of alcohol, drugs, or medication.**
 - Use the machine only in daylight.
 - Keep all nuts and bolts tight and keep the equipment in good operating condition.
-

A Note to All Users

Under California law, and the laws of some other states, you are not permitted to operate an internal combustion engine using hydrocarbon fuels without an engine spark arrester. This also applies to operation on US Forest Lands. All DR SP22 MOWERS shipped to California, New Mexico, Oregon and Arizona are equipped with spark arresters. Failure of the owner or operator to maintain this equipment in compliance with state regulations is a misdemeanor under California law and may be in violation of other state and/or federal regulations. Contact your State Park Association or the appropriate state organization for specific information in your area.

No list of warnings and cautions can be all-inclusive. If situations occur that are not covered by this manual, the operator must apply common sense and operate this DR SP22 MOWER in a safe manner. Contact us at www.DRpower.com or call 1-800-DR-OWNER (376-9637) for assistance.

Chapter 2: Setting Up the DR SP22 MOWER

It may be helpful to familiarize yourself with the controls and features of your DR SP22 MOWER as shown in **Figure 1** before beginning these procedures. If you have any questions at all, please feel free to contact us at www.DRpower.com.

DR SP22 MOWER Controls and Features



Figure 1

Specifications

Engine	See Engine Manufacturers Manual for detailed Engine information
Cutting Width	560mm (22 inch)
Cutting Height	9 Heights, 1" to 3.4"
Deck Material	Cast Aluminum
Wheel Size	8" x 1.75" Front, 9" x 1.75" Rear
Dimensions	63" L x 24" W x 43" H
Weight	108 lbs.

Parts Supplied in Shipping Box:

* = Hardware Package (**Figure 2**)

Item #	Part #	Description	Qty
1*	32257	Knob, Handlebar	4
2*	32256	Bolt, Carriage, Short	2
3*	32296	Bolt, Carriage, Long	2
4*	32530	Nut, Nylon Lock M6	2
5*	32293	Guide, Pull Start	1
6	32368	Mulching Plug	1
7	32290	Lower Handlebar	1
8		Upper Handlebar Assembly	1

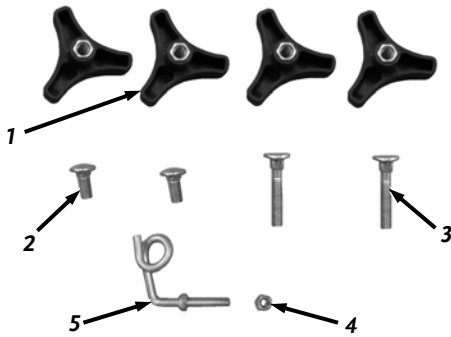

Figure 2

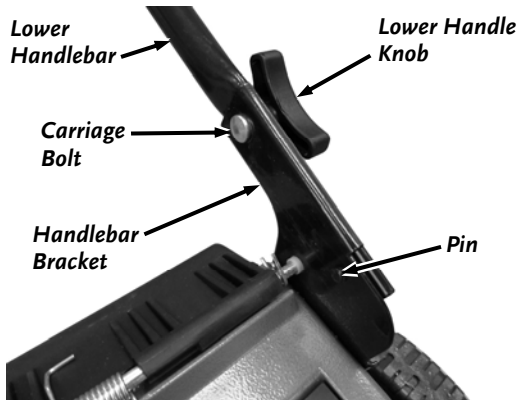

Figure 3

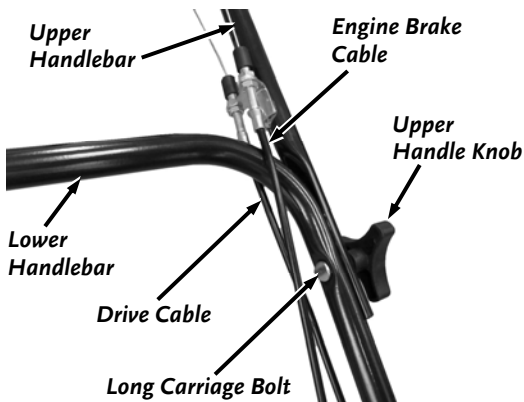

Figure 4

Compare the contents of the Shipping Box with the "Parts Supplied" list above. If you have any questions please contact us at www.DRpower.com or call 1-800-DR-OWNER (376-9637) for assistance.

Assembling the Mower

Tools Needed:

- 10mm Wrench

! WARNING

Folding or unfolding the handle improperly can damage the cables, causing an unsafe operating condition.

- Do not damage the cables when folding or unfolding the handle.
- If a cable is damaged, contact us at www.DRpower.com.

Installing the Handlebars

1. Insert the pins of the Lower Handlebar into the holes of Handlebar Brackets (**Figure 3**). Insert the short Carriage Bolts through the Lower Handlebar and Brackets. Install and tighten the Lower Handlebar Knobs onto the Carriage Bolts as tight as you can by hand.

Note: make sure the Drive Cable goes under the Lower Handlebar for proper clearance in the next step.

2. Carefully position the Upper Handle with Cables onto the Lower Handlebar (**Figure 4**). Insert the long Carriage Bolts through the Upper and Lower Handlebars. Install and tighten the Upper Handlebar Knobs onto the Carriage Bolts as tight as you can by hand.

Installing the Pull Start Guide and Handle

Note: The Pull Start Guide may have already been installed at the factory.

1. Ensure that one of the Locknuts is screwed all the way onto the threads of the Pull Start Guide (**Figure 5**).
2. Insert the Pull Start Guide into the lowest open hole on the right hand side of the Upper Handlebar.
3. Secure the Pull Start Guide to the Upper Handlebar with a Locknut using a 10mm Wrench.
4. Pull the Pull Start Handle up to the Pull Start Guide and insert the Rope into the Guide as shown.

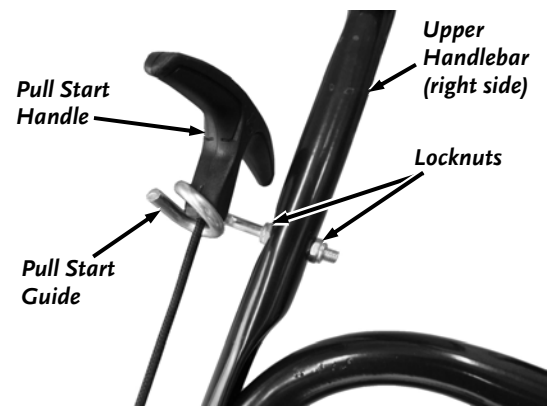

Figure 5

Installing the Grass Catcher

Note: If you are installing the Grass Catcher prior to operation, remove the Mulching plug shipped in the rear of the machine (not shown).

1. Hold the Discharge Guard in the upright position (**Figure 6**).
2. Place the Hooks of the Grass Catcher onto the Discharge Chute Bar on both sides.
3. Lower the Guard onto the Grass Catcher.

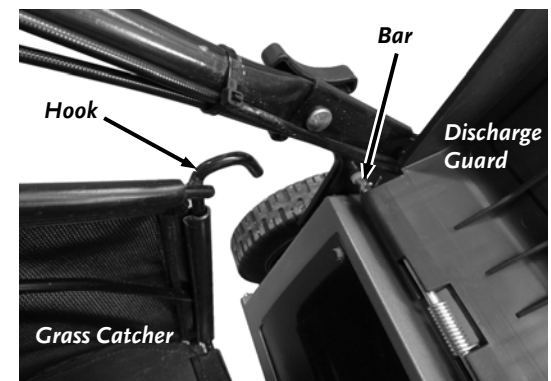

Figure 6

Adding Oil and Gasoline

Engine Oil	SAE 30: above 40 degrees F; 10w-30: 10-90 degrees F; 5w-30: 40 degrees F or below
Fuel	Unleaded gasoline

Note: Refer to the Engine Manufacturers Manual for more detailed Engine information.

Tip: To avoid confusion, we recommend leaving the caps ON the Fuel and Oil Fills until you are ready to pour either gasoline or oil into the correct Fill.

Note: You will need approximately 15 to 22 ounces of high detergent oil depending on Engine type. Use only high detergent oil classified "For Service SF, SG, SH, SJ" or higher. Do not use special additives. Other types of oil could cause problems with the operation of your machine. Please refer to your Engine Owner's Manual provided with your mower for detailed information on oil quantity and cold temperature oil specifications.

NOTICE

- You must add oil before starting the engine. This machine is shipped without oil. Traces of oil may be in the reservoir from factory testing, but **you must add oil before starting the engine**. Fill the reservoir slowly, checking the level frequently to avoid overfilling.
- To get an accurate reading when checking the oil level:
 - The machine should be on a level surface.
 - To ensure an accurate oil level reading, **DO NOT** screw the dipstick down.

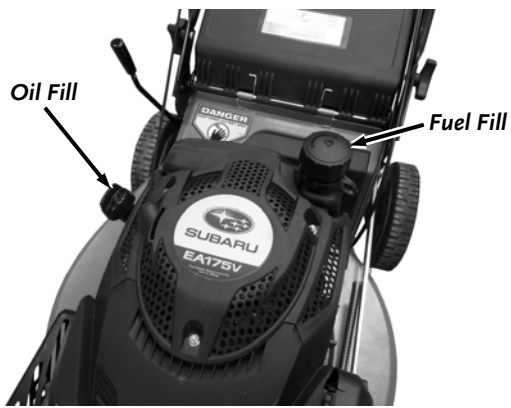

Figure 7

1. Place the machine on a level surface remove the Dipstick (**Figure 7**).
2. Machines are shipped with no oil. Initially add 16 oz. of the oil recommended by the Engine Manufacturer. Wait one minute for the oil to settle.
3. Replace the Dipstick, but **DO NOT** screw it in, to ensure an accurate reading and then remove it to check the oil level (clean the Dipstick with the rag after checking).
4. Continue adding a few ounces of oil at a time, rechecking the Dipstick until the oil reaches the fill mark. Be careful not to overfill.
5. Replace the Dipstick and screw all the way down when full.

WARNING

Gasoline is extremely flammable and explosive. A fire or explosion from gasoline can burn you and others.

- To prevent a static from igniting the gasoline, place the container and/or mower directly on the ground before filling, not in a vehicle or on an object.
- Fill the tank outdoors when the engine is cold. Wipe up spills.
- Do not handle gasoline when smoking or around an open flame or sparks.
- Store gasoline in an approved fuel container, out of the reach of children.

-
6. Remove the Gas Fill Cap and fill the Gas Tank with fresh, unleaded gas (with a minimum of 85 Octane) to approximately 1" to 1-1/2" below the top of the fill neck to allow for fuel expansion (**Figure 7**). Be careful not to overfill and reinstall the Gas Fill Cap before starting the engine. See your Engine Owner's Manual for more detailed information.

NOTE: To refill the gas tank, turn the engine OFF and let the engine cool at least five minutes before removing the gas fill cap.

Chapter 3: Operating the DR SP22 MOWER

It may be helpful to better familiarize yourself with the features of your Mower by reviewing **Figure 1** in Chapter 2 before beginning the steps outlined in this chapter.

! WARNING

Read and understand all warnings listed in “Chapter 2 General Safety Rules” before operating this Mower.

Adjusting the Cutting Height

! WARNING

Adjusting the cutting height may bring you into contact with the mowing blade, causing serious injury.

- Stop the engine and wait for all moving parts to stop.
- Do not put your fingers under the housing when adjusting the cutting height.

Use the Height Adjustment Lever to set all four Wheels to the same cutting height as desired (**Figure 8**). Pull Lever outward, move Lever to desired position, and release Lever to lock in notch.

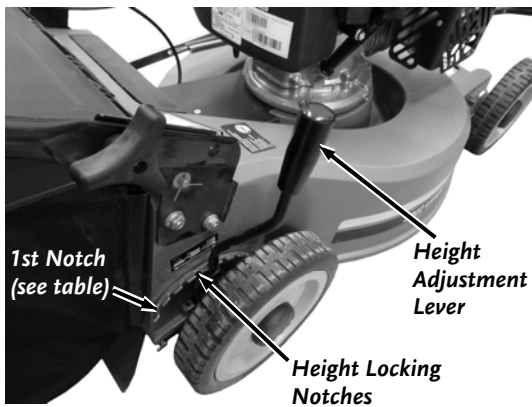

Figure 8

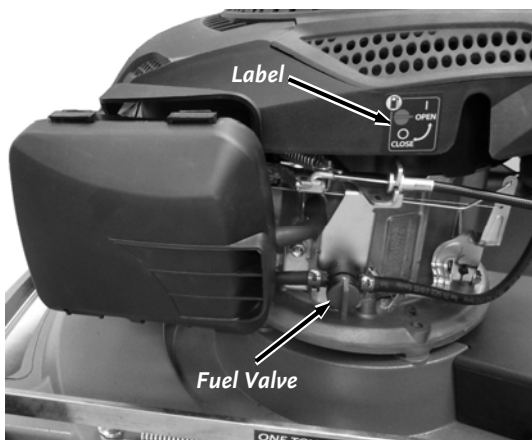

Figure 9

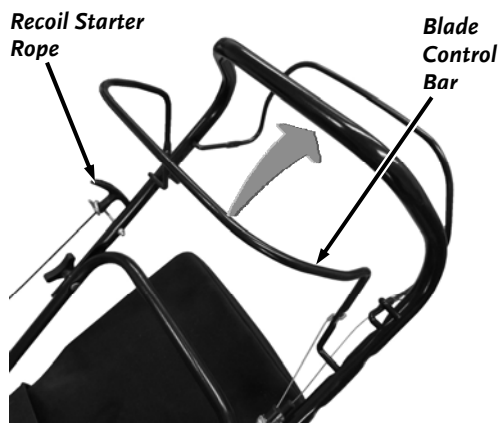

Figure 10

Notch Position	Cutting Height
1st: Fully towards rear of mower	1.0 inch (2.5 cm)
2nd:	1.2 inch (3.0 cm)
3rd:	1.4 inch (3.5 cm)
4th:	1.7 inch (4.3 cm)
5th:	2.0 inch (5.0 cm)
6th:	2.3 inch (6.0 cm)
7th:	2.7 inch (6.8 cm)
8th:	3.0 inch (7.8 cm)
9th: Fully towards front of mower	3.4 inch (8.6 cm)

Starting the Engine

! DANGER

Always be aware that the blade is cutting (spinning) while engine is running. The blade is sharp; contacting the blade can result in serious personal injury.

! CAUTION

If the engine has been running, the muffler will be hot and can severely burn you. Keep away from the hot muffler.

1. Turn the Fuel Shutoff Valve to the “OPEN” position (**Figure 9**).
2. Stand behind the Mower. Hold the Blade Control Bar against the Handle in the “Operating Position” (**Figure 10**).
3. Grasp the Recoil Starter Rope Handle, and pull slowly until resistance is felt. Then pull rapidly to overcome engine compression and to prevent kick back and start the engine.

Note: When starting the engine for the first time or if the engine has run out of fuel, it will take extra cranking time to move fuel from the tank to the engine.

Stopping the Engine and Blade

1. Release the Blade Control Bar to stop the Engine (**Figure 11**).

! WARNING

- Stop the engine and wait for all moving parts to stop before leaving the operating position.
- When you release the blade control bar, both the engine and blade should stop within 3 seconds. If they do not stop properly, stop using your mower immediately and contact us at www.DRpower.com or call toll-free 1-800-DR-OWNER (376-9637).

Forward Travel

TO TRAVEL FORWARD

1. Pull the Drive Bar to Handle and hold (**Figure 12**).

Note: You can vary the speed of the machine by slightly releasing the Drive Bar to allow belt slip on the Transmission.

TO STOP TRAVEL FORWARD

1. Release the Drive Bar.

Note: Do not pull mower backward when you are using self forward travel.

Using the Grass Catcher

1. Hold the Discharge Guard in the upright position (**Figure 13**).
2. Place the Hooks of the Grass Catcher onto the Discharge Chute Bar on both sides.
3. Lower the Guard onto the Grass Catcher.
4. Reverse the previous procedures for emptying the Bag.

Operating Tips

- Clear the area of sticks, stones, wire, branches, and other debris that the blade could hit.
- Avoid striking solid objects with the blade. Never deliberately mow over any object.
- If the mower strikes an object or starts to vibrate, **immediately stop the engine, disconnect the wire from the spark plug**, and examine the mower for damage.
- For best performance, install a new blade before the cutting season begins.
- Replace the blade when necessary with a DR Power Equipment replacement blade.



Figure 11

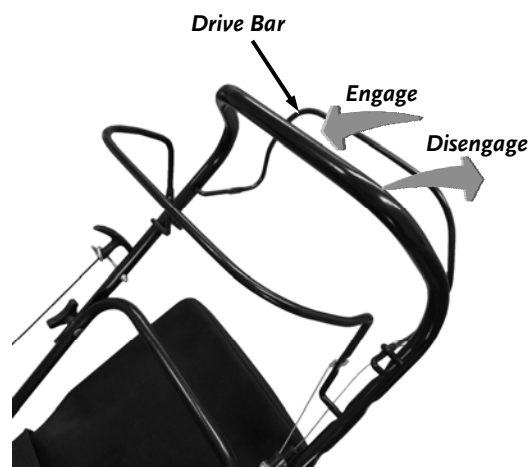

Figure 12

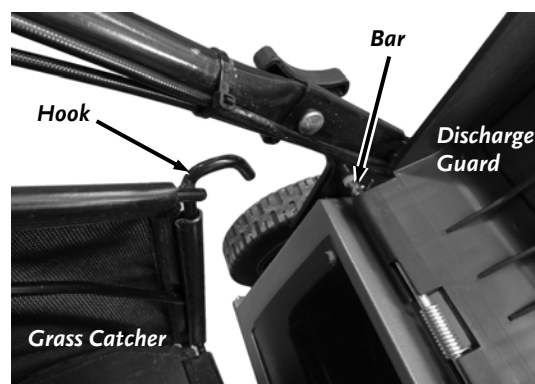

Figure 13

Mulching Plug

The Mulching plug can be inserted under the Discharge Guard into the hole at the rear of the Mower. This will keep the clippings contained in the housing for more complete processing (mulching) of leaves and grass clippings.

Cutting Grass

WARNING

Wet grass or leaves can cause serious injury if you slip and contact the blade. Mow only in dry conditions.

- The Engine always operates at full throttle when mowing to assure better mowing performance and proper discharge of material. The engine is equipped with an Auto-choke, which will cause the engine to run at a lower RPM when first started. Allow the engine to come up to full speed prior to use.
- Do not cut more than a third of the grass blade at a time.
- When cutting grass over 6 inches (15 cm) tall, mow at the highest cutting height setting and walk slower; then mow again at a lower setting for the best lawn appearance. If the grass is too long, the mower may plug and cause the engine to stall.
- Mow only dry grass or leaves. Wet grass and leaves tend to clump on the yard and can cause the mower to plug or the engine to stall.
- Alternate the mowing direction. This helps disperse the clippings over the lawn for even fertilization.
- If the finished lawn appearance is unsatisfactory, try one or more of the following:
 - Replace the blade or have it sharpened.
 - Walk at a slower pace while mowing.
 - Raise the cutting height on your mower.
 - Cut the grass more frequently.
 - Overlap cutting swaths instead of cutting a full swath with each pass.

Cutting Leaves

- After cutting the lawn, ensure that half of the lawn shows through the cut leaf cover. You may need to make more than one pass over the leaves so more of the lawn shows through.
- Slow down your mowing speed if the mower does not cut the leaves finely enough.

Slope Operation

WARNING

Slopes are a major factor related to slip and fall accidents, which can result in severe injury. Operation on all slopes requires extra caution. If you feel uneasy on a slope, do not mow it.

- Mow across the face of slopes; never up and down. Exercise extreme caution when changing direction on slopes.
 - Watch for holes, ruts, bumps, rocks, or other hidden objects. Uneven terrain could cause a slip and fall accident. Tall grass can hide obstacles.
 - Do not mow on wet grass or excessively steep slopes. Poor footing could cause a slip and fall accident.
 - Do not mow near drop-offs, ditches, or embankments. You could lose your footing or balance.
-

Chapter 4: Maintaining the DR SP22 MOWER

Regular maintenance is the way to ensure the best performance and long life of your machine. Please refer to this manual and the engine manufacturer's owner's manual for maintenance procedures. Service intervals listed in the checklist below supersede those listed in the engine manufacturer's owner's manual.

⚠ WARNING

Before performing any maintenance procedure or inspection on the Mower, release the blade control bar to shut down the engine, wait 5 minutes for parts to cool and then remove the spark plug wire keeping it away from the spark plug.

Regular Maintenance Checklist

PROCEDURE	BEFORE EACH USE	EVERY 25 HOURS	EVERY 100 HOURS
Check Engine Oil Level	▲		
Check General Equipment Condition	▲		
Check Blade for Sharpness	▲		
Remove grass clippings and dirt from under the housing	▲		
Clean Engine Exterior & Cooling Fins	▲		
Check Belt Tension and Condition		▲	
Clean Air Filter		▲	
Change Engine Oil	1 st time 5 hours	▲	
Replace Air Filter		▲	
Replace Spark Plug			▲

NOTICE

To get an accurate reading when checking the oil level:

- - The machine should be on a level surface.
- - To ensure an accurate oil level reading, DO NOT screw the dipstick down.

Checking the Engine Oil Level

1. Remove the dipstick, wipe it clean, and insert it back into the Oil Fill but do not screw it in (**Figure 14**).
2. Remove the dipstick and check the oil level (**Figure 15**). If the oil level is below the "Add" mark on the dipstick, slowly pour oil into the oil fill tube until the oil level reaches the "Full" line on the dipstick. Do not overfill. (See your Engine users manual for detailed information on Oil type and quantity)
3. Insert and fully screw in the dipstick when the Oil level is correct.

Changing Engine Oil

Tools and Supplies Needed:

- Oil (see engine owner's manual)
- Rags and approved waste oil Container

Run the engine a few minutes before changing the oil to warm it. Warm oil flows better and carries more contaminants.



Figure 14

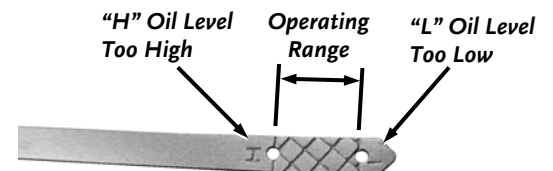

Figure 15

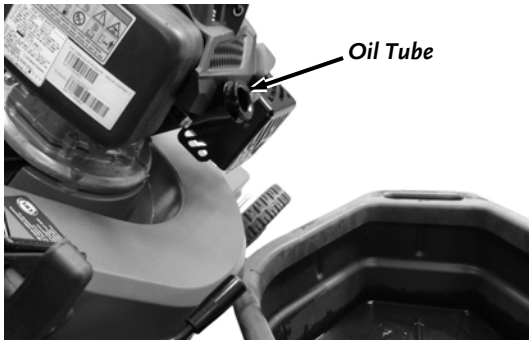

Figure 16

1. Ensure the Fuel Cap is tight and remove the Dipstick (**Figure 14**).
2. Tip the mower onto its side (with the air filter up) to drain the used oil out through the oil fill tube (**Figure 16**). Lower the machine when done.
3. Slowly pour fresh oil into the oil fill tube until the oil level reaches the Full line on the dipstick. See procedures in "Checking the Engine Oil Level" for reference. Do not overfill.
4. Insert and fully screw in the dipstick when the Oil level is correct.
5. Dispose of the used oil properly at a local recycling center.

Replacing the Blade

Tools and Supplies Needed:

- 5/8" Socket and Torque Wrench
- Block of Wood

IMPORTANT: You will need a torque wrench to install the blade properly. If you do not have a torque wrench or are uncomfortable performing this procedure, contact us at www.DRpower.com.

⚠ WARNING

The blade is sharp; contacting the blade can result in serious personal injury. Wear gloves when servicing the blade.

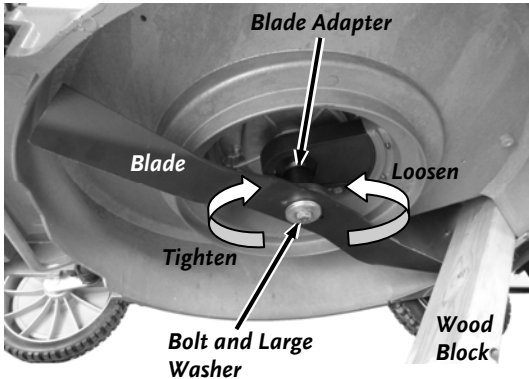

Figure 17

Examine the blade whenever you run out of gasoline. If the blade is damaged or cracked, replace it immediately. If the blade edge is dull or nicked, have it sharpened or replace it.

1. Block up the Mower to gain access under the Deck.
2. Use a block of wood to hold the blade steady (**Figure 17**).
3. Remove Bolt, Large Washer and the blade, saving all mounting hardware.

Note: The Blade Adapter might come off the Engine Shaft. Ensure that the Blade Adapter and Shaft Key are in place when reinstalling the Blade.

IMPORTANT: Make sure in the following step that you position the curved ends of the blade pointing up toward the mower housing.

4. Position the new Blade with its holes aligned with the pins of the Blade Adapter and secure with the large Washer and Bolt.
5. Use a torque wrench to tighten the blade bolt to 30 ft-lb (40 Nm).

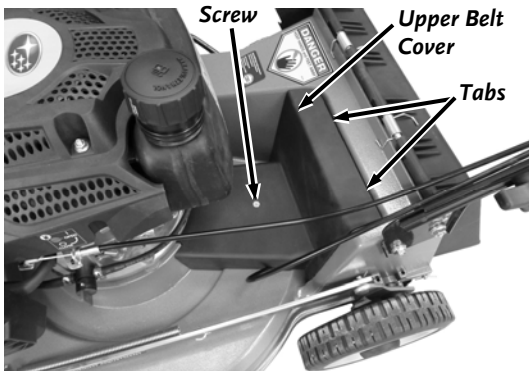

Figure 18

Replacing the Drive Belt

Tools and Supplies Needed:

- Philips Head Screwdriver
- 12mm Wrench
- 8mm Wrench

1. Remove the Screw from the upper Belt Cover and remove the Belt Cover (**Figure 18**).

Note: There are two Tabs at the back of the Belt Cover that snap into the Frame of the Mower. You will need to push down and forward at the area of the Tabs to release the Cover from the Frame.

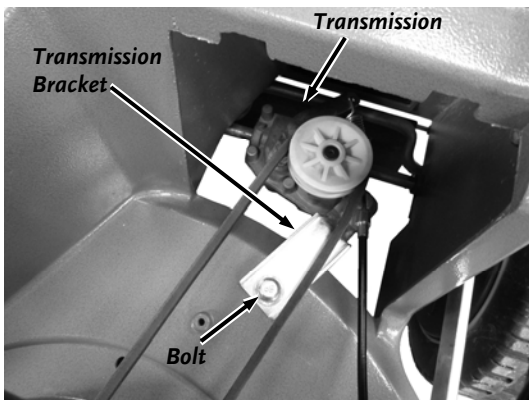

Figure 19

2. Remove the Transmission Bracket Bolt using a 12mm Wrench (**Figure 19**).

- Slide the Transmission Bracket over (step 1) so the Transmission can be tilted forward (step 2) to allow the Belt to be removed from the pulley (**Figure 20**).
- Remove the two Screws from the top side of the lower Belt Guard with an 8mm Wrench (**Figure 21**).
- Remove the Blade as described on the previous page.
- Pull the Lower Belt Guard down enough so you can remove the Belt from the Engine Pulley (**Figure 22**).
- Remove the Belt from the machine.
- Install the new Belt using the reverse order of the previous steps.
- When the Transmission is rotated back into position, make sure the metal portion of the Transmission Cable is inserted fully into hole in the Transmission Post (**Figure 23**). There is a flat area on the metal portion of the Cable that must rest against the Transmission Bracket. Also check that the Cable Spring is attached to the Transmission.

Adjusting the Engine Brake and Drive Cables

The Cables are adjusted at the factory and should not need any initial adjustment. A worn Belt and machine use however can cause the Cables to need some adjustment. Perform the following procedures if the Engine is not stopping properly when the upper Bar is released or if the Wheels are not engaging properly when the lower Bar is pulled to the Handlebar.

- Loosen the top Jam Nut and tighten the bottom Jam Nut to tighten the Cable (**Figure 24**).
- Loosen the bottom Jam Nut and tighten the top Jam Nut to loosen the Cable.
- Tighten both Nuts towards each other against the Bracket to hold the adjustment location.

Cleaning the Mower

- For best results, clean the mower soon after you have completed mowing.
- With the engine running on a flat paved surface, spray a stream of water in front of the right rear wheel.
- The water will splash into the path of the blade, cleaning out the clipping.
- When no more clippings come out, stop the water and move the mower to a dry area.
- Run the engine for a few minutes to dry the housing.

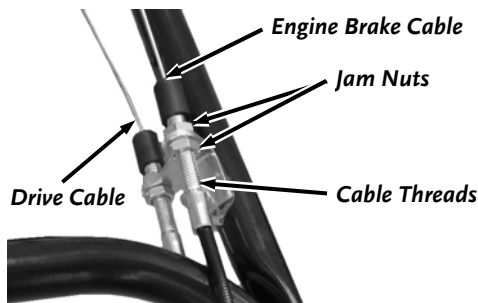

Figure 24

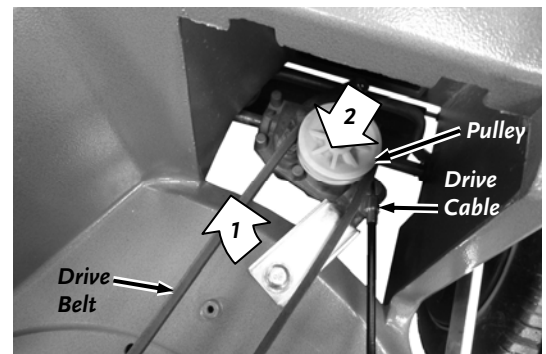

Figure 20

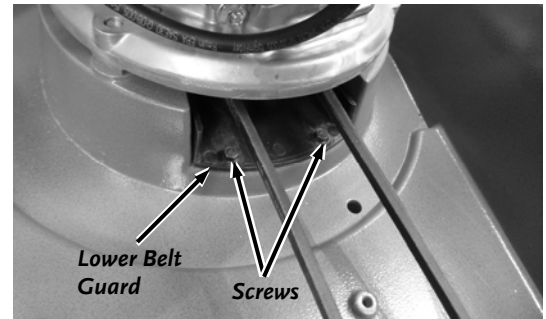

Figure 21

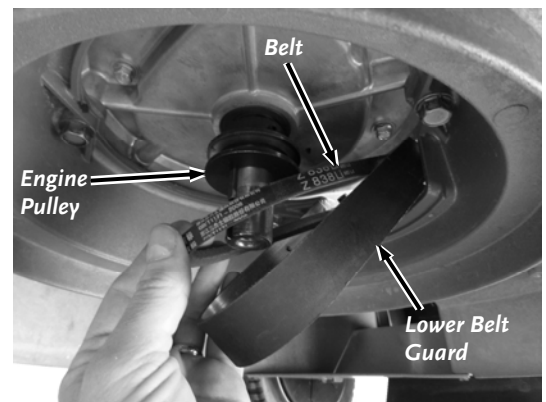

Figure 22

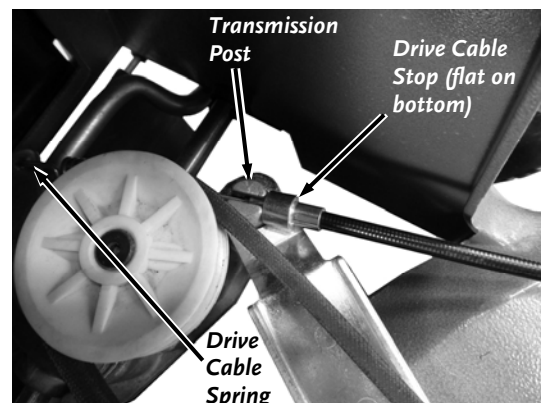

Figure 23

Chapter 5: Troubleshooting

Most problems are easy to fix. Consult the Troubleshooting Table below for common problems and their solutions. If you continue to experience problems, contact us at www.DRpower.com or call toll-free 1-800-DR-OWNER (376-9637) for support.

WARNING

Before performing any maintenance procedure or inspection on the Mower, release the blade control bar to shut down the engine, wait 5 minutes for parts to cool and then remove the spark plug wire keeping it away from the spark plug.

Troubleshooting Table

SYMPTOM	POSSIBLE CAUSE
<i>Recoil will not pull out or is difficult to pull.</i>	<ul style="list-style-type: none"> ⇒ The engine is difficult to start in heavy or high grass. Move the mower to a clean dry surface. ⇒ Make sure the blade control lever is in operating position. ⇒ Check the Engine oil level, the Engine may be seized. ⇒ There may be an oil compression lock in the Cylinder. Take out the Spark Plug; hold a rag over the Spark Plug hole and pull the Recoil Cord several times to blow out any oil in the Cylinder. Wipe off the Spark Plug and reinstall it. ⇒ The Recoil may be broken or jammed. Visit our web site at www.DRPower.com or call 1-800-DR-OWNER (376-9637) for assistance.
<i>The Engine will not start (Please refer to the Engine Owner's Manual for Engine-specific procedures.)</i>	<ul style="list-style-type: none"> ⇒ Make sure the blade control lever is in operating position. ⇒ Make sure the fuel valve is in the ON position. Refer to engine operator manual. ⇒ The engine is difficult to start in heavy or high grass. Move the mower to a clean dry surface. ⇒ Check for proper attachment of the Spark Plug wire. ⇒ Check that the Engine has the right amount of clean oil. If the oil is dirty, change it following the procedure in Chapter 2. ⇒ You should be using fresh, clean, unleaded gas. If the gas is old, change it. Use a fuel stabilizer if you keep gas longer than one month. ⇒ Check that the Air Filter is clean. If it is dirty, change it following the procedure in the Engine Owner's Manual. ⇒ Make sure that the Spark Plug is clean. If the Spark Plug is dirty or cracked, change it. If it's oily, leave it out, hold a rag over the Spark Plug hole and pull the Recoil Cord several times to blow out any oil in the Cylinder, then wipe off the Spark Plug and reinsert it. ⇒ If the Engine still will not start, visit our web site at www.DRPower.com or call 1-800-DR-OWNER (376-9637) for assistance.
<i>The Engine will not stop.</i>	<ul style="list-style-type: none"> ⇒ Release the blade control lever. If the engine does not stop when the blade control lever is released, pull the spark plug wire off the spark plug using insulated handle pliers. ⇒ Check the engine stop cable. Replace the cable if bent or damaged.

Troubleshooting Table (continued)

SYMPTOM	POSSIBLE CAUSE
<i>Engine smokes.</i>	<ul style="list-style-type: none"> ⇒ Check the oil level and adjust as needed. ⇒ You may be operating the machine on too great an incline. ⇒ Check the Air Filter and clean or replace as needed. ⇒ You may be using the wrong oil - too light for the temperature. Refer to your Engine Owner's Manual for detailed information. ⇒ Clean the Engine cooling fins and the carburetor housing if they are dirty. ⇒ If the Engine still smokes, visit our web site at www.DRPower.com or call 1-800-DR-OWNER (376-9637) for assistance.
<p><i>The Engine lacks power or is not running smoothly.</i></p> <p><i>(Please refer to the Engine Owner's Manual for Engine-specific procedures.)</i></p>	<ul style="list-style-type: none"> ⇒ Check the height of cut settings. Raise the height of cut if the grass is high. ⇒ Allow the engine to fully warm up if it is cold. The Auto Choke feature requires a cold engine to heat to operating temperature prior to achieving full operating RPM. ⇒ Check the bottom of the mower housing. Clean the blade housing of grass and other debris. ⇒ Check for debris (hay seed, etc.) clogging the Air Filter Intake and clean out as required. ⇒ The Engine's Blower Housing, Throttle Linkage, and Cooling Fins should be free of debris. Clean them following the instructions in the Engine Owner's Manual. ⇒ Check that the Air Filter is clean. If it is dirty, change it following the procedure in the Engine Owner's Manual. ⇒ Remove the Spark Plug wire and dry the connection with a rag. ⇒ The Spark Plug may be dirty or cracked, change it. If it's oily, leave it out, hold a rag over the Spark Plug hole and pull the Recoil Cord several times to blow out any oil in the Cylinder, then wipe off the Spark Plug and reinsert it. ⇒ You should be using fresh, clean, unleaded gas. If it is old, change it. Use a fuel stabilizer if you keep gas longer than one month. ⇒ Check that the Engine has the right amount of clean oil. If it is dirty, change it following the procedure in Chapter 4. ⇒ If your Engine still lacks power, visit our web site at www.DRPower.com or call 1-800-DR-OWNER (376-9637) for assistance.
<i>Excessive Vibration</i>	<ul style="list-style-type: none"> ⇒ Remove the blade and check the blade and balance. ⇒ Check for a bent or broken blade. A DAMAGED BLADE IS DANGEROUS AND MUST BE REPLACED. ⇒ Check the blade adapter. Replace a broken blade adapter. ⇒ If the vibration continues, visit our web site at www.DRPower.com or call 1-800-DR-OWNER (376-9637) for assistance.
<i>The grass will not discharge correctly.</i>	<ul style="list-style-type: none"> ⇒ Clean the bottom of the mower housing. ⇒ Check for a badly worn blade. Remove and sharpen the blade. For safety, replace the blade every two years with a DR Power replacement blade. ⇒ Check grass catcher. Clean and dry grass catcher as needed. ⇒ The engine speed is too slow. Place throttle control in FAST position.
<i>The grass is not cut even.</i>	<ul style="list-style-type: none"> ⇒ Make sure the blade is sharp. ⇒ Check for a bent or broken blade. A DAMAGED BLADE IS DANGEROUS AND MUST BE REPLACED. ⇒ Check the blade adapter. Replace a broken blade adapter. ⇒ Check grass catcher. Clean and dry grass catcher as needed.

Schematic – Engine and Drive Assembly

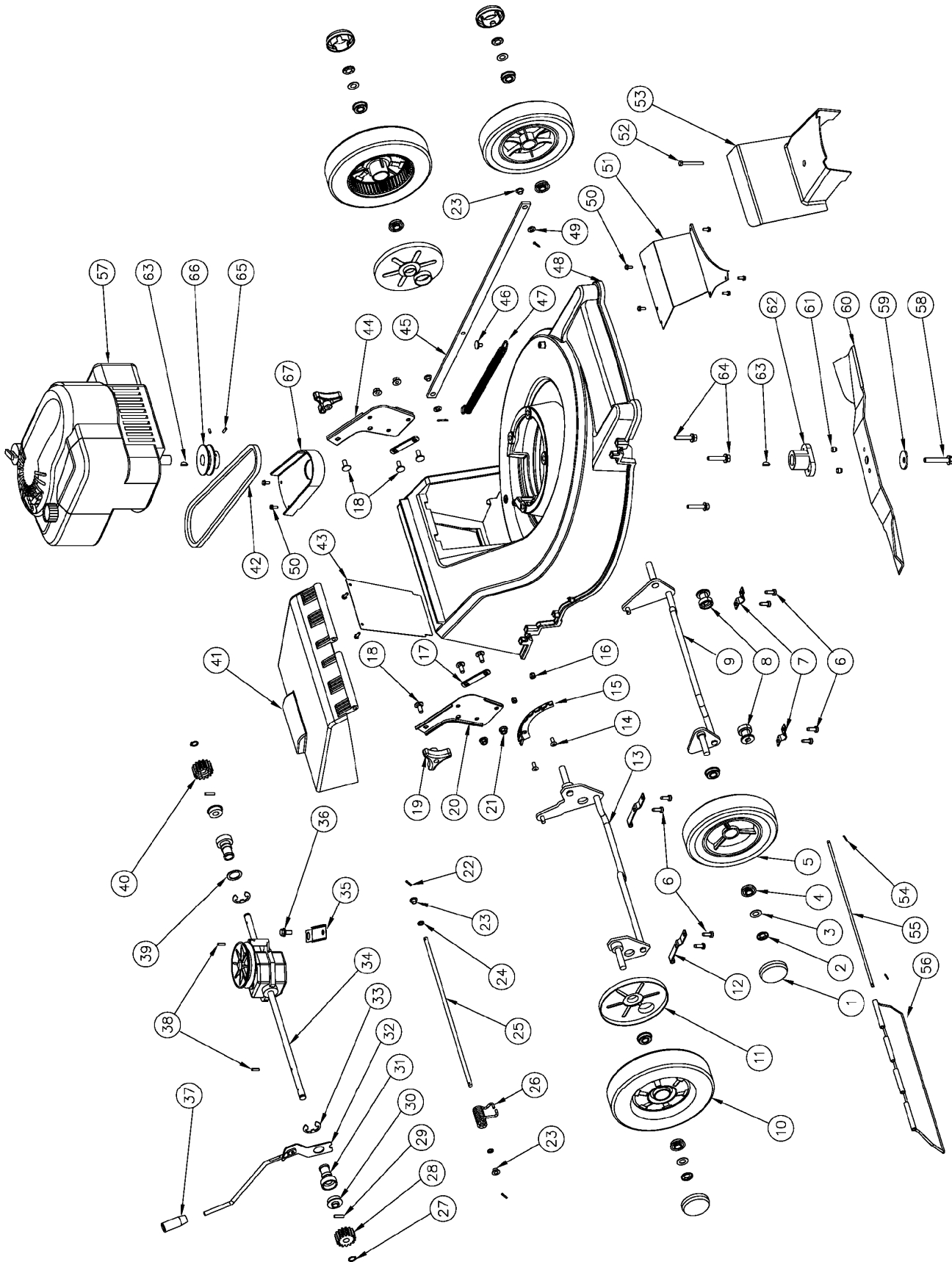

Parts List - Handlebar Assembly

NOTE: Part numbers listed are available through DR Power Equipment.

<u>Ref#</u>	<u>Part#</u>	<u>Description</u>	<u>Ref#</u>	<u>Part#</u>	<u>Description</u>
1	32530	Nut, Nylon lock M6	7	32294	Bracket, Cable
2	32289	Cable, Engine	8	32295	Bar, Blade Engagement
3	32290	Lower Handlebar	9	32539	Bolt, Hex
4	32291	Upper Handlebar	10	32296	Bolt, Carriage, Long
5	32292	Bar, Drive	11	32297	Cable, Drive
6	32293	Guide, Pull Start	12	32298	Bagger, Assembly

Schematic – Handlebar Assembly

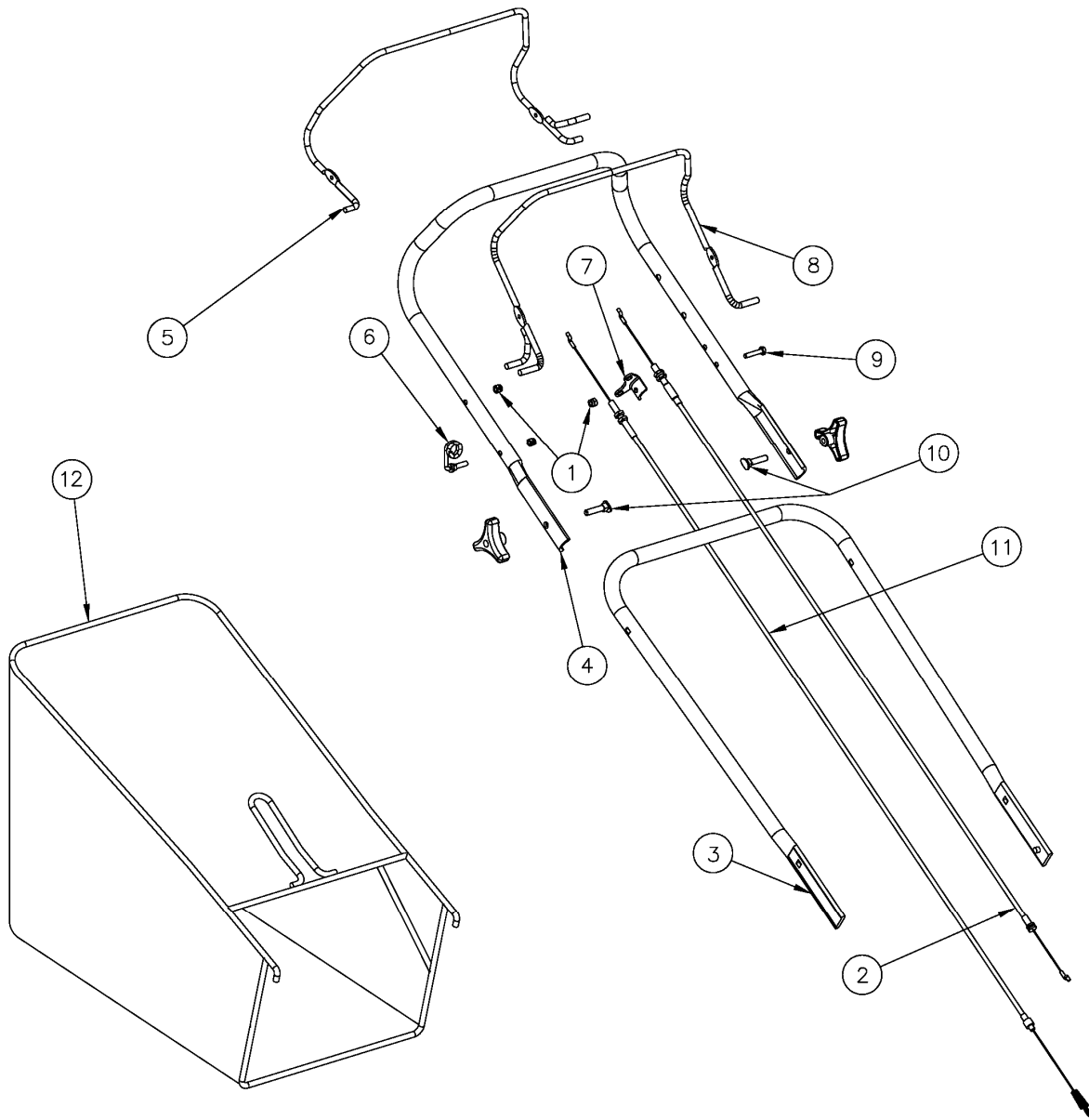

Daily Checklist for the DR SP22 MOWER

WARNING

Before performing any maintenance procedure or inspection on the Mower, release the blade control bar to shut down the engine, wait 5 minutes for parts to cool and then remove the spark plug wire keeping it away from the spark plug.

To help maintain your DR SP22 MOWER for optimum performance, we recommend you follow this checklist each time you use your Mower.

- Check the engine oil level.
- Check the fuel level.
- Check that the blades, blade bolts and cutter assembly are not worn or damaged.
- Check the general condition of the Mower, e.g.; nuts, bolts, welds, etc.

End of Season and Storage

WARNING

Before performing any maintenance procedure or inspection on the Mower, release the blade control bar to shut down the engine, wait 5 minutes for parts to cool and then remove the spark plug wire keeping it away from the spark plug.

Immediately prepare your mower for storage at the end of the season or if the mower will not to be used for 30 days or more. See your Engine owners manual for detailed engine care and storage procedures.

- When mower is to be stored, remove all dirt, grease, leaves, etc.
- On the last refueling of the year, add fuel stabilizer to the fuel as directed by the engine manufacturer. Run the mower until the engine stops from running out of fuel. Prime the engine and start it again. Allow the engine to run until stops. When you can no longer start the engine, it is sufficiently dry. Remove the spark plug, add 1 oz. (30 ml) of oil through the spark plug hole, and pull the starter rope slowly several times to distribute oil throughout the cylinder to prevent cylinder corrosion during the off- season.
- Clean the exterior of the unit to remove all dirt, grease, and any other foreign material. To prevent rust, touch up painted surfaces that have been scratched or chipped.
- Store your mower indoors and cover it with a suitable protective cover to give protection from dust and dirt. Do not use plastic. Plastic cannot breathe which allows condensation to form and will cause some mower parts to rust.



75 MEIGS ROAD, P.O. BOX 25, VERGENNES, VERMONT 05491