

DR[®] RAPIDFIRE™ LOG SPLITTER



TRAY Kit# 27589

These instructions will aid in the installation of the Tray accessory for your Rapidfire Log Splitter. Please keep these instructions with your Log Splitter Safety and Operating Manual for future reference.

Tools and Supplies Needed:

- Two 9/16" Wrenches
- Sawhorse
- Wheel Chocks

WARNING

Before performing any maintenance procedure or inspection, stop the engine, wait five (5) minutes to allow all parts to cool. Disconnect the spark plug wire, keeping it away from the spark plug. Disconnect the Battery Terminals (Electric start only).

1. Remove the Handles by pulling the Handle Pins and removing the Bolts and Locknuts using two 9/16" Wrenches (**Figure 1**).
2. Loosen (do not remove yet) the eight Bolts, Flat Washers and Locknuts securing the two Carriages with two 9/16" Wrenches (**Figure 2**).
3. Install Wheel Chocks and place a Sawhorse under the front part of the Frame to lift the Supporting Leg off the ground (**Figure 3**).
4. Remove the eight Bolts, Flat Washers and Locknuts securing the two Carriages with two 9/16" Wrenches and store the Carriages.

Note: The Support Leg and Handle Brackets will come off when the forward Carriage hardware is removed. Store the Handle Brackets with the Carriages. All Hardware will be reused.

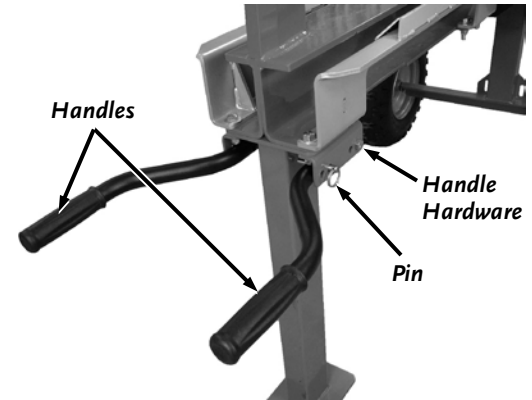

Figure 1

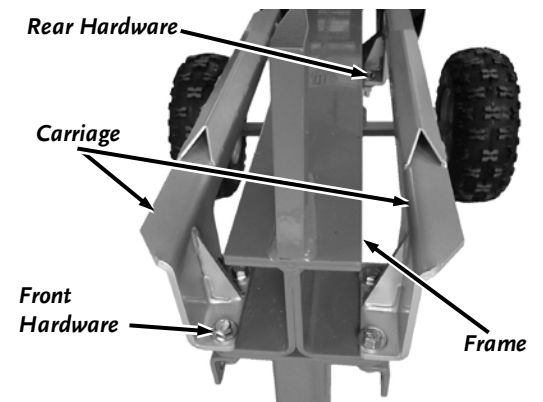

Figure 2

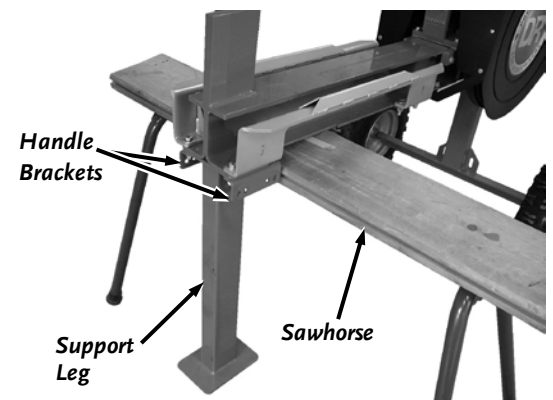

Figure 3

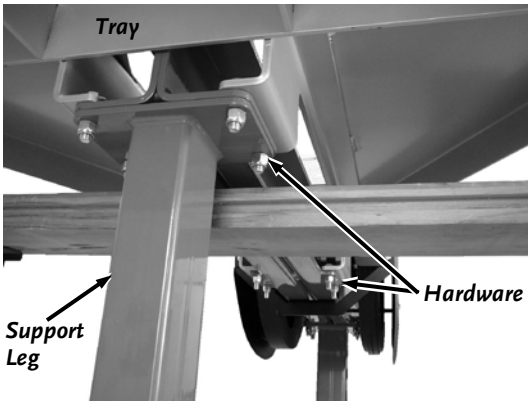

Figure 4

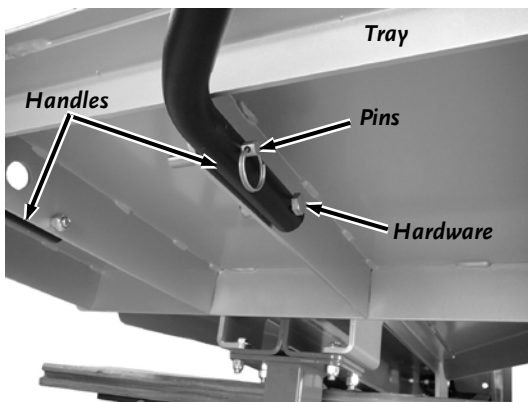

Figure 5

CAUTION

You will need another person to position the Tray. The Tray weighs over 60lbs. and lifting alone may cause injury.

5. Position the Tray onto the mounting holes of the Frame and loosely reinstall the four rear Bolts and Locknuts into the Tray and Frame (**Figure 4**).
6. Position the Support Leg and install the four front Bolts and Lock Washers through the Tray, Frame and Leg. Tighten all Tray hardware using two 9\16" Wrenches
7. Install the Handles on the two center ribs of the front of the Tray with the Bolts and Locknuts using two 9\16" Wrenches (**Figure 5**). Rotate the Handles up and secure with the Pins.
8. Remove the Sawhorse and Wheel Chocks from the machine.

If you have any questions please contact us at www.DRpower.com or call 1-800-DR-OWNER (376-9637) for assistance.

