

CHIPPER/SHREDDER

Operating & Assembly Instruction Manual

Model: Tractor Attachment Chipper/Shredder

TPH-184CHP

This manual contains information concerning proper and improper operating procedures, warnings, maintenance, troubleshooting, assembly, and tips. Everyone who operates this machine should read these instructions and be thoroughly familiar with them.

SECTION I – SAFETY



This symbol points out important safety instructions, which if not followed, could endanger the personal safety and/or property of yourself and others. Read and follow all instructions in this manual before attempting to operate your shredder/chipper. Failure to comply with these instructions may result in personal injury. When you see this symbol - **heed its warning**.

**THIS MACHINE IS CAPABLE OF INFLICTING SERIOUS INJURY
IF
OPERATED IMPROPERLY -- READ WARNINGS & CAUTION LABELS.**

INTENDED USE

Never use your shredder/chipper for any other purpose than shredding and chipping limbs or other lawn and garden debris. It is designed for this use and any other use may cause serious injury.



DANGER: *Rotating cutting blade.*

Keep hands and feet out of inlet and discharge opening while machine is running.

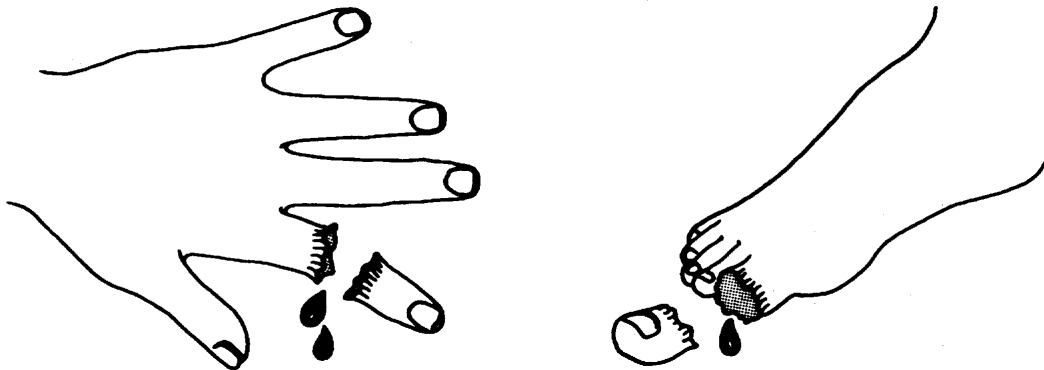

DANGER: This machine can **CRUSH, GRIND, CUT**, and **SEVER** parts of your body if they enter the inlet or discharge area of your shredder/chipper.



DANGER: Your shredder/chipper was built to be operated according to the rules for safe operation in this manual. **As with any type of power equipment, carelessness or error on the part of the operator can result in serious injury.** If you violate any of these rules, you may cause serious injury to yourself or others.

MAKE CERTAIN THAT ALL SAFETY LABELS ON THIS EQUIPMENT ARE KEPT CLEAN AND IN GOOD CONDITION. IF YOU NEED REPLACEMENT LABELS, ORDER BY PART NUMBER.

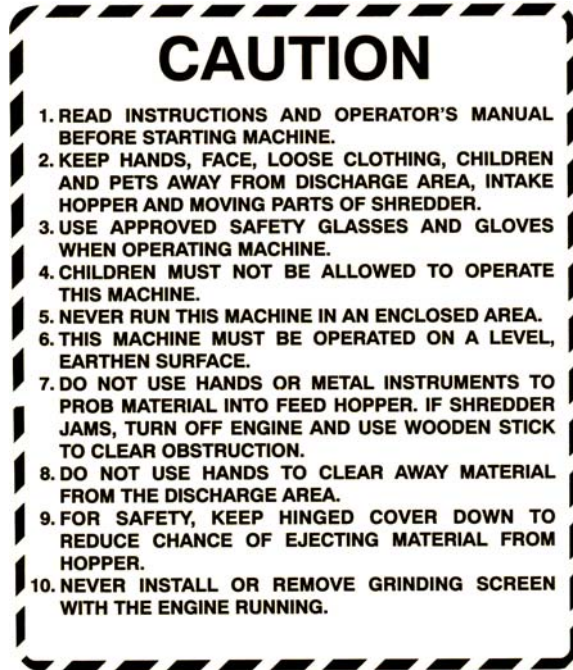

080-0962



080-0967



091-0044



091-0055



091-0057



091-0062



091-0059

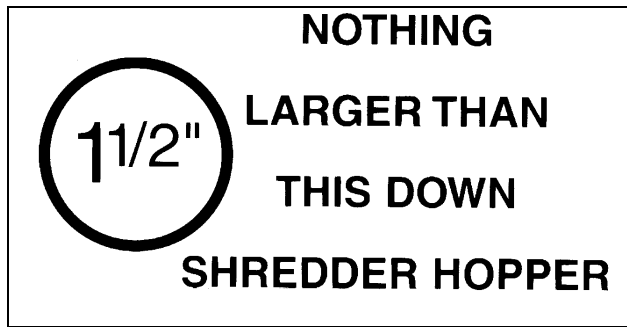

091-0064



091-0088



091-0380





091-0381

WARNING

THIS MACHINE IS DESIGNED TO OPERATE AT 540 RPM ONLY. DO NOT OPERATE AT A FASTER SPEED WHICH MAY CAUSE SERIOUS INJURY TO THE OPERATOR OR BYSTANDERS AND COULD CAUSE DAMAGE TO THE MACHINE WHICH WILL NOT BE COVERED UNDER WARRANTY.

091-0385

	 WARNING
	<p>Rotating flywheel and blade could cause severe injury. BEFORE OPENING INSPECTION DOOR: Shut down tractor. Wait for PTO shaft and all moving parts to come to a complete stop. Disconnect PTO shaft from tractor.</p>

©2005 HCS, LLC www.safetylabel.com 05035 Reorder No. 091-0442

091-0442

	 DANGER
	<p>Entanglement Hazard. Rotating drive shafts will cause serious injury or death. Keep clothes, skin, hair, hands, etc. away from drive shaft. Shut down tractor, wait for all moving parts to come to a complete stop, disconnect PTO shaft before performing any inspection, maintenance or repair to this machine.</p>

©2005 Hazard Communication Systems, LLC www.safetylabel.com 05039 Reorder No. 091-0445

091-0445

SAFE OPERATION PRACTICES

TRAINING

- Read this owner's manual carefully in its entirety before attempting to assemble this machine. Read, understand, and follow all instructions on the machine before operation. Be completely familiar with the controls and the proper use of the machine before operating it. Keep this manual in a safe place for future and regular reference and for ordering replacement parts.
- Know how to stop the unit and disengage the controls quickly.
- Never allow children to operate the unit. Never allow adults to operate the equipment without proper instruction. Only responsible individuals who are familiar with these rules of safe operation should be allowed to use your unit.
- Keep the area of operation clear of all persons, particularly small children and pets. Stop the engine when they are in the vicinity of the unit. Keep work area clean and clear of branches or obstacles, which could cause you to stumble or fall.
- Keep in mind that the operator or user is responsible for accidents or hazards occurring to other people, their property, and themselves.
- Your shredder/chipper is a powerful tool, not a plaything. Exercise extreme caution at all times. Your unit has been designed to shred and chip. Do not use it for any other purpose.
- If situations occur which are not covered in this manual, use care and good judgment. Contact your place of purchase for additional assistance.

PREPARATION

- Thoroughly inspect the area where the equipment is to be used and remove all foreign objects.
- Do not operate the machine without wearing adequate outer garments and safety goggles. Always wear safety glasses or goggles during operation and while performing any adjustment or repair, to protect eyes from foreign objects that may be thrown from the machine. Be sure your glasses or goggles fit properly.
- Avoid loose-fitting clothes and use protective footwear that will improve footing on slippery surfaces. Shirt and slacks that cover the arms and legs and steel-toed shoes are recommended. Secure hair above shoulders. Do not wear loose clothes or jewelry that can be caught in moving parts. Never operate a unit in bare feet, sandals or sneakers. Wear gloves when feeding material into the shredder hopper or chipper chute. Be sure your gloves fit properly and do not have loose cuffs or drawstring.
- Never attempt to make any adjustments without shutting off the tractor and disengaging the P.T.O. drive shaft.

OPERATION

- Never place your hands, feet, or any part of your body in the shredder hopper, chipper chute, discharge opening, or near or under any moving part while the shredder/chipper is running. Keep clear of the discharge opening at all times. If it becomes necessary to push material into the shredder hopper or chipper chute, use a small diameter stick, NOT YOUR HANDS.
- Keep your face and body back from the shredder hopper and chipper chute to avoid accidental bounce back of any material.
- The shredder/chipper is designed to be run with the weight of the unit on the ground. Shredding or chipping with the unit while it is off the ground can result in injury to yourself or others, or damage to the machine which may not be covered under warranty.
- The machine should only be operated on a level surface. Never operate your unit on a slippery, wet, muddy, or icy surface.
- Exercise caution to avoid slipping or falling.
- Stay alert for hidden hazards or traffic. Do not carry passengers.
- If the cutting mechanism strikes a foreign object or if your machine should start making an unusual noise or vibration, immediately stop the tractor and wait for all moving parts to come to a complete stop. After the machine has come to a complete stop proceed as follows:
 - Inspect for any damage.

- Repair or replace any damaged parts before restarting and operating the machine.
- If the machine should start to vibrate abnormally, immediately stop the tractor and wait for all moving parts to come to a complete stop and inspect for the cause. Vibration is generally a warning sign of trouble.
- Disengage the P.T.O. drive shaft when leaving the operating position.
- Disengage the P.T.O. when moving the shredder/chipper.
- Stop the tractor and disconnect the P.T.O. drive shaft when making any repairs, adjustments and inspections.
- Take all possible precautions as recommended by the manufacturer when leaving the machine unattended. Stop the tractor and remove the key if so equipped.
- Before cleaning, repairing, or inspecting, shut off the tractor and make certain the flywheel and all moving parts have come to a complete stop.
- Never run this machine in an enclosed area as the exhaust from the tractor engine contains carbon monoxide, which is an odorless, tasteless, and deadly poisonous gas.
- Keep all guards and safety devices in place and operating properly. Do not operate the machine if all safety guards are not in place.
- Do not use the unit with the shredder hopper or chipper hopper removed.
- Keep children and pets away.
 - Tragic accidents can occur if the operator is not alert to the presence of small children.
 - Keep children out of the work area and under the watchful eye of a responsible adult other than the operator.
 - Be alert and turn the unit off if a child enters the area.
 - Never allow children to operate the shredder/chipper.
- Do not overload or attempt to shred or chip material beyond manufacturers recommendation. Personal injury or damage to the machine could result.
- Never operate the machine at high transport speeds or on hard or slippery surfaces.
- Never allow bystanders near the unit while running.
- Only use accessories approved for this machine by the manufacturer. Read, understand, and follow all the instructions provided with the approved accessory.
- Only operate unit in good daylight. Do not operate unit at night or in dark areas where your vision may be impaired.
- Use extreme caution when reversing or pulling the machine towards you.
- This machine is designed to operate at 540 RPM only. Do not operate at a faster speed which may cause serious injury to the operator or bystanders and could cause damage to the machine which will not be covered under warranty.
- Never pick up or transport the machine while the P.T.O. drive shaft is engaged.
- Do not operate while under the use of alcohol, drugs, or medication. A clear mind is essential for safety.
- Do not allow anyone who is not alert to operate this machine.
- When feeding material into this equipment, be extremely careful that pieces of metal, rocks, or other foreign objects are not included. Personal injury or damage to the machine could result.
- Keep area of discharge clear of people, animals, buildings, glass or anything else that will obstruct clear discharge, cause injury or damage. Wind can also change discharge direction, so be aware.
- Do not allow an accumulation of processed material to build up in the discharge area as this will prevent proper discharge and can result in kickback from the shredder hopper or chipper chute.

MAINTENANCE AND STORAGE

- Keep machine, attachments and accessories in safe working condition.
- Check hardware at frequent intervals for proper tightness. Never operate your shredder/chipper in poor mechanical condition or when in need of repair. Be sure all safety guards and shields are in proper position. These safety devices are for your protection.
- Always refer to the operator's manual for important details if the machine is to be stored for an extended period.
- Follow the manufacturer's recommendations for safe loading, unloading and storage of machine.
- If it is necessary for any reason to unclog the feed intake or discharge openings or to inspect or repair the machine where a moving part can come in contact with your body or clothing, shut the tractor off and allow all moving parts to come to a complete stop before attempting to unclog, inspect or repair.
- Check the knife mounting screws at frequent intervals for proper tightness. Also visually inspect the knife for wear or damage. Replace the knife with parts that meet original equipment specifications.
- Knives should be checked for sharpness and the bolts attaching them to the flywheel for tightness every 8-10 hours of operation.
- Check the gap between the knife and wear plate every time you sharpen or replace the knife, or every 8-10 hours of operation.
- Never tamper with safety devices. Check their proper operation regularly.
- Inspect the belt each time you use the unit. Look for damage, worn areas or tears. Do not use the unit if this condition exists.
- This machine is designed to operate at 540 RPM only. Do not operate at a faster speed that may cause serious injury to the operator or bystanders and could cause damage to the machine that will not be covered under warranty.

SECTION II - ASSEMBLY & INSTALLATION

PACKAGE CONTENTS

SKID	POLY BAG	BOLT BAG	PART #	WHERE USED
SHREDDER/CHIPPER	OWNER'S MANUAL	1 EA - 1/4" X 1/4" X 1 1/2" KEY	080-0080	PTO SHAFT
CHIPPER HOPPER	WARRANTY CARD	4 EA - 5/16-18 X 3/4" CARRIAGE BOLT	090-0462	CHIPPER HOPPER
SHREDDER HOPPER	SAFETY GLASSES	4 EA - 5/16 FLAT WASHERS	090-0233	CHIPPER HOPPER
P.T.O. DRIVE SHAFT	BOLT BAG	8 EA - 5/16-18 NYLOCK NUT	090-0460	4 EA - CHIPPER HOPPER 4 EA - SHREDDER HOPPER
POLYBAG		2 EA - 3/8-16 X 3/8" SET SCREWS	080-0056	PTO SHAFT
		2 EA - 5/16-18 X 1 1/4" HHCS	090-0089	SHREDDER HOPPER
		2 EA - 5/16-18 X 1 1/2" HHCS	090-0090	SHREDDER HOPPER
		4 EA - ANTI-VIBRATION MOUNTS	500-0068	SHREDDER HOPPER

TOOLS REQUIRED FOR ASSEMBLY & INSTALLATION

- 1/2" Wrench or socket

ASSEMBLY

STEP I - UNPACKING AND CHECKING CONTENTS

- Remove the all items from the crate.
- After unpacking the crate, compare the contents with the list above.
- If any parts are missing, contact your place of purchase.
- Assembly should be done on a clean, level surface.

STEP II - ASSEMBLING THE CHIPPER HOPPER

- Assemble chipper hopper to the basic machine using four each 5/16"-18 x 3/4" carriage bolts, 5/16"-18 nylock nuts and 5/16" flatwashers from the bolt bag. Put head of bolt inside hopper with threads sticking out. Tighten all hardware with a 1/2" wrench.

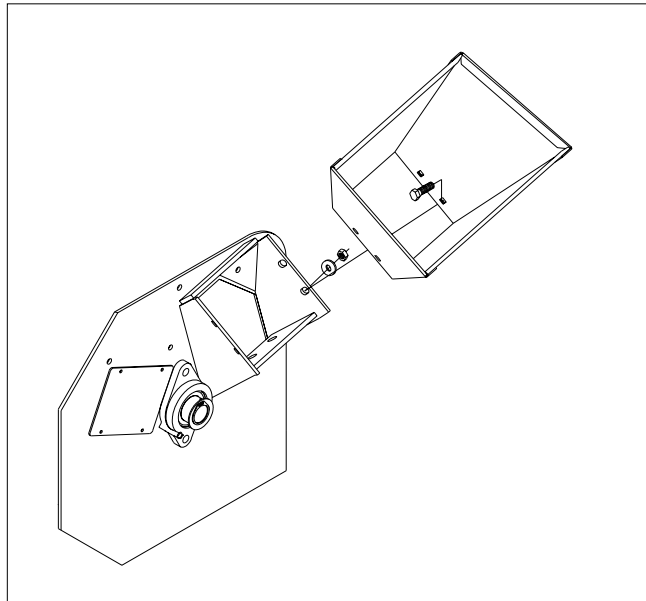

STEP III – ATTACHING THE SHREDDER HOPPER

- To attach the shredder hopper, push the four vibration dampeners (item #28) up into the mount holes on the hopper.
- With the vibration dampeners in the hopper mount holes from step 1, place the hopper on top of the unit. **NOTE:** the slanted side of the hopper faces the discharge end of the shredder/chipper. Align the holes in the side plates with the vibration dampeners.
- Push the four bolts up through the side plates and thread them into each vibration dampener until one or two threads appear. Put the locknuts in place on top of the bolts coming up through the vibration dampeners. Hold the locknut with a wrench and tighten the bolt until two threads are completely through the nut. **DO NOT OVER TIGHTEN AS THIS WILL DAMAGE THE VIBRATION DAMPENER AND POSSIBLY LEAD TO FURTHER DAMAGE TO YOUR MACHINE.**

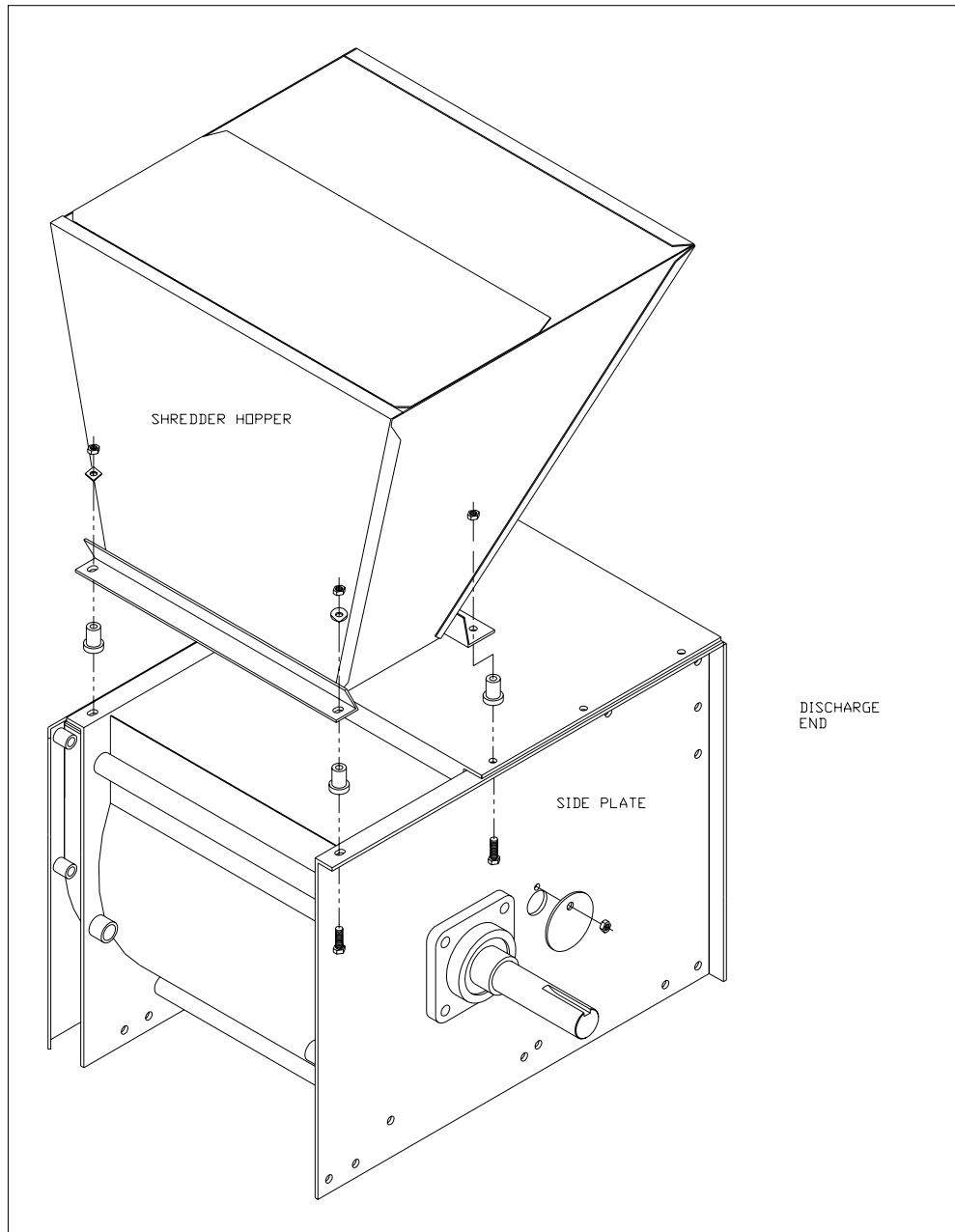

INSTALLATION

- Many tractors permit direct mounting to the lower support pins on the frame of the shredder/chipper. If the lower hitch arms on your tractor do not have enough inward adjustment to attach to the lower support pins, a pair of pin extensions may be required to allow proper mounting of the shredder/chipper to the tractor.
- The P.T.O. drive shaft provided with this machine is sized to fit a standard category 1 P.T.O. (1 3/8" x 6 spline).
- The P.T.O. shaft on the tractor that is to use this shredder/chipper **must rotate clockwise** when viewing the P.T.O. from the rear of the tractor. If the P.T.O. rotates counterclockwise, you must have your tractor modified by installing a gear box to reverse the direction of rotation.
- Depending on the mounting dimensions of the tractor, it may be necessary to have your dealer or yourself modify the length of the P.T.O. drive shaft that is included with this shredder/chipper. Instructions follow for this procedure.
- This machine is designed to operate at 540 RPM only. Do not operate at a faster speed that may cause serious injury to the operator or bystanders and could cause damage to the machine that will not be covered under warranty.

P.T.O. DRIVE SHAFT MODIFICATION

The P.T.O. drive shaft included with this shredder/chipper may be too long for your tractor. To shorten the driveshaft proceed as follows.

- Remove the guard.

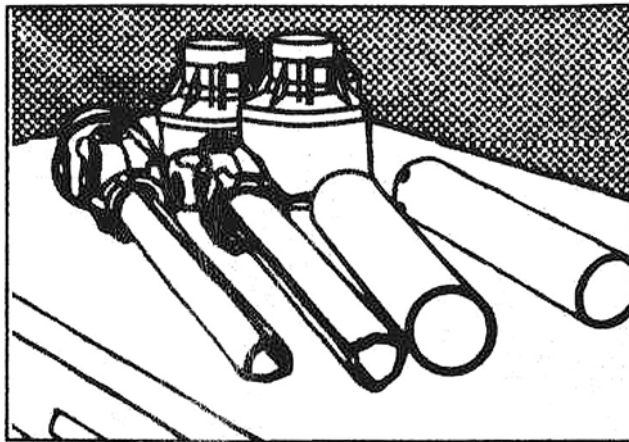

- Cut the shaft tubes to the required length.

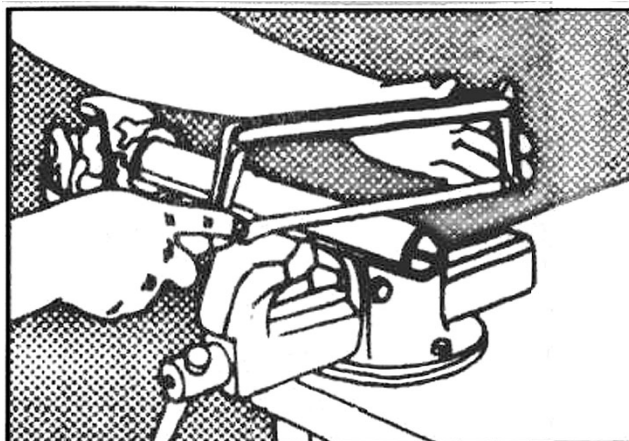

Round off all edges.

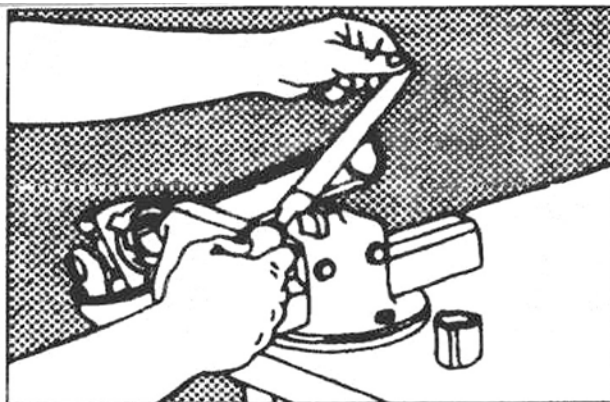

- Shorten the guard tubes to the same length.

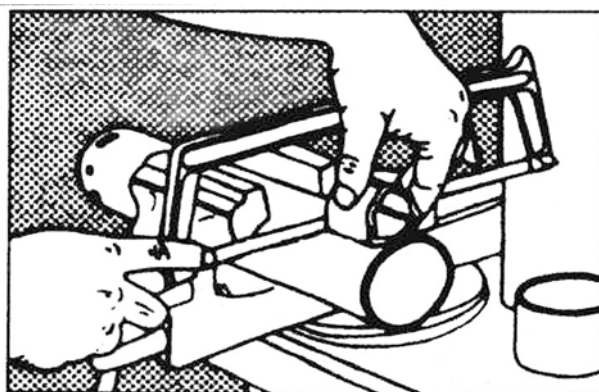

- Grease the shaft tubes and reassemble.

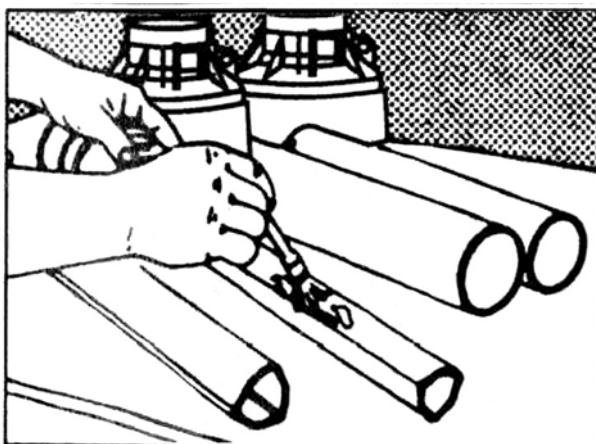

**REFER TO THE BROCHURE THAT COMES WITH THE P.T.O. DRIVE SHAFT FOR
ADDITIONAL DRIVE SHAFT INFORMATION.**

SECTION III - OPERATION

THIS TRACTOR SHREDDER/CHIPPER ATTACHMENT HAS BEEN DESIGNED TO OPERATE ON CATEGORY 1 TRACTORS.

**THIS MACHINE IS DESIGNED TO OPERATE AT 540 RPM ONLY!
DO NOT OPERATE AT A FASTER SPEED. THIS CAN CAUSE SERIOUS INJURY TO THE OPERATOR OR BYSTANDERS AND COULD CAUSE DAMAGE TO THE MACHINE THAT WILL NOT BE COVERED UNDER WARRANTY.**

THE SHREDDER/CHIPPER IS DESIGNED TO BE RUN WITH THE WEIGHT OF THE UNIT ON THE GROUND. SHREDDING OR CHIPPING WITH THE UNIT OFF THE GROUND CAN RESULT IN INJURY TO YOURSELF OR OTHERS.

Operation Notes

- To activate the shredder/chipper, engage the P.T.O. with the tractor running at idle. Gradually increase engine speed until you achieve a P.T.O. speed of 540 RPM.
- Proper rotor speed is 2200 RPM +/- 200 RPM.
- When viewed from the operator zone, the rotor and flywheel turn in a clockwise direction. This rotation pulls branches into the shredder/chipper.
- Always wear protective gloves and safety glasses during operation of the shredder/chipper.
- If it becomes necessary to push material into the chipper hopper, only use a wood stick, never your hands or anything steel.
- Never assume you know where the knife is. You don't know where it is. Always keep hands out of all feed hoppers.
- Keep area of discharge clear of people, animals, buildings, glass or anything else that will obstruct clear discharge, cause injury or damage.
- If the cutting mechanism strikes a foreign object or if your machine should start making an unusual noise or vibration, immediately stop the tractor and wait for all moving parts to come to a complete stop. After the machine has come to a complete stop proceed as follows:
 - Inspect for any damage.
 - Repair or replace any damaged parts before restarting and operating the machine.
- If the machine should start to vibrate abnormally, immediately stop the tractor and wait for all moving parts to come to a complete stop and inspect for the cause. Vibration is generally a warning sign of trouble.
- Disengage the P.T.O. drive shaft when leaving the operating position.
- Disengage the P.T.O. when moving the shredder/chipper.
- When feeding material into this equipment, be extremely careful that pieces of metal, rocks, or other foreign objects are not included. Personal injury or damage to the machine could result.
- Adjust the baffle plate to direct the discharge material down and away from the shredder/chipper. The discharge end of the machine has three holes for different discharge direction.
- If you shred or chip without any type of screen in place, be certain the baffle plate is held away from the rotor with one of the screen and baffle rods. Failure to do this will allow the baffle plate to swing backward into the grinding chamber and become damaged by the rotation of the rotor and hammers.

SECTION IV – SHREDDING & CHIPPING

THIS SHREDDER/CHIPPER WAS DESIGNED FOR SHREDDING LEAFY GARDEN OR ORGANIC MATERIAL AND CHIPPING LIMBS OR BRANCHES. NEVER USE THIS MACHINE FOR ANY OTHER PURPOSE AS IT COULD CAUSE SERIOUS INJURY.

CONTACT WITH INTERNAL ROTATING HAMMERS WILL CAUSE SERIOUS PERSONAL INJURY. DO NOT PUT HANDS, FACE, FEET OR CLOTHING INTO THE SHREDDER HOPPER, CHIPPER CHUTE, DISCHARGE OPENING OR NEAR THE DISCHARGE AREA AT ANY TIME.

MAINTENANCE AND SERVICE SHOULD ONLY BE PERFORMED AFTER THE TRACTOR ENGINE IS OFF, THE P.T.O. DRIVE SHAFT IS DISCONNECTED, AND ALL MOVING PARTS HAVE COME TO A COMPLETE STOP. USE ONLY A WOODEN STICK TO CLEAR JAMMED MATERIAL AFTER ALL MOVING PARTS HAVE STOPPED COMPLETELY.

SAFETY FIRST

- Always wear protective gloves and safety glasses during operation of the shredder/chipper.
- Never allow your hands or any part of your body or clothing inside the feed hoppers or discharge area of the shredder/chipper.
- Keep all protective guards and warning labels on the machine and in good working condition.
- Always stand clear of the discharge area when the shredder/chipper is running.
- Keep your face and body back from the feed hoppers to avoid being struck by any material that may bounce back.
- Keep proper balance and footing while operating the shredder/chipper.
- If it becomes necessary to push material into the feed hoppers, only use a wood stick, never your hands or anything steel.
- Never assume you know where the chipper knife is. You do not know where it is.
- Keep area of discharge clear of people, animals, buildings, glass or anything else that will obstruct clear discharge, cause injury or damage. Wind can also change discharge direction, so be aware.
- Always keep hands out of the feed hoppers.
- Never operate the shredder/chipper without the chipper hopper in place.
- Do not transport the shredder/chipper with the P.T.O. engaged.

PROCESSING MATERIAL

- Your shredder/chipper can process dry or green material.
- Green material will process quicker and easier than dry material.
- Soft wood processes easier than hard wood.
- Your operator experience will teach you how different materials shred and chip.
- Your operator experience will teach you how fast you can process different materials.
- Most materials process well with the standard screen.

- When chipping branches, sometimes a tail will be left at the end of a branch. To avoid this, rotate the branch as it is fed into the chute.
- Rotating the branch as you feed it into the machine will improve chipping performance.
- Optional screens are available for both greater and less reduction of the material being processed through the shredder hopper.

USING THE SHREDDER HOPPER

- The shredder hopper is located on the top of the unit and is the opening into which all materials to be shredded should be fed. Most organic materials can be shredded. A flex guard, or blowback shield is secured to the hopper. Material must be pushed past this flap using a wooden stick in order to enter the main chipper-shredder chamber where revolving steel hammers do the shredding. **The blowback shield is an important feature. It prevents kickback of materials! Do not use your machine unless the blowback shield is securely fastened in place.**
- Due to the wide variety of materials that can be shredded, and their very different physical characteristics, only feed limited quantities of any material into the hopper at first. The amount and length of material can be increased if you find that the material is being processed without any difficulty. Your judgment and operator experience is very important. Be sure not to overload the machine by feeding too much material into the hopper at one time. If you hear the RPM's decreasing, stop feeding material into the machine at once. Do not resume feeding the machine until it has returned to full speed.
- The maximum diameter of material that can be shredded is 1 ½". Any larger material should be fed through the chipper-hopper. Material larger than 1 ½" can cause serious damage to any of the internal parts of the chipper-shredder chamber. The unit should be inspected after every use for bent hammers, missing spacers, damage to the screen or any other obvious problems. If damage occurs, the rotor assembly can become unbalanced causing excessive vibration. If used in this state, damage can occur. Do not use the machine if vibration is present. Vibration is generally a warning sign of trouble.
- Several small branches can be fed into the shredder-hopper at once providing their combined diameter is less than 1 1/2". Branches longer than three feet should be cut to make them more manageable. Green materials should be allowed to dry, or processed in small batches with dry materials to avoid winding around the rotor assembly.

MATERIALS BEST SUITED FOR SHREDDING

- | | | |
|-------------------|-------------------|-------------------|
| • Leaves | • Flowers | • Corn Stalks |
| • Roots | • Soil | • Palm frond tops |
| • Grass clippings | • Garden debris | • Potato vines |
| • Straw | • Hedge clippings | • Tomato vines |
| • Hay | • Kitchen Waste | • Paper |
| • Small branches | • Manure | |

NOTE - The hammers within the chipper-shredder chamber can tug suddenly at material being fed into the shredder-hopper. Do not hold on tightly to branches and vines, and don't feed material straight down into the hopper with your arm pointing downward toward the opening. Instead, keep your arms parallel to the ground and several inches above the top edge of the hopper.

USING THE CHIPPER HOPPER

- This chipper-hopper is mounted on the side of the machine and is designed to chip the larger, heavier materials that the shredder-hopper isn't designed to handle. Branches fed into the chute are turned into "chips" by the revolving chipper knife mounted on a flywheel. The chipper-hopper can chip branches and vines ranging in size from 1" to 4 1/2" in diameter. Cut your materials into manageable lengths before feeding them into the chipper.
Note: The chipper hopper must be securely bolted to the side of your equipment before using the machine!
- The chipper is designed to draw the complete limbs in through the chipping area. Do not force material into the chipper. If the machine does not self-feed, the chipper knives need replaced or sharpened or the gap between the knives and the wear plate needs adjusting.
- Extremely hard knots will not process very well. Short stubs that have not self-fed through the chipper can be pushed through with the next branch to be chipped. **DO NOT THROW REMAINING STUBS OR UNCHIPPABLE KNOTS INTO THE SHREDDER-HOPPER. DAMAGE WILL RESULT.**
- Cut chipping material into manageable lengths of no more than five or six feet long before chipping them.
- Overloading the shredder/chipper will cause the rotor speed to decrease. If you hear the RPM's decreasing, stop feeding material into the machine until the machine has returned to full speed.
- Normally the branches will feed themselves into the chipper-hopper if trimmed to an appropriate size. Once the self-feeding starts, release the branch quickly to avoid ripping from your hands.

MATERIALS BEST SUITED FOR CHIPPING.

- Branches, vines or stalks from 1 1/2" to 4 1/2" in diameter.

USE COMMON SENSE WHEN USING YOUR SHREDDER/CHIPPER.

- **LEARN TO RECOGNIZE THE CHANGE IN THE SOUND OF YOUR MACHINE WHEN IT IS OVERLOADED.**
- **BECOME FAMILIAR WITH SUCCESSFUL OPERATING CONDITIONS AND AVOID THOSE THAT CAN OVERLOAD AND DAMAGE THE MACHINE.**
- **IF THE MACHINE BECOMES JAMMED BY OVERLOADING OR ANY OTHER CAUSE, STOP THE MACHINE IMMEDIATELY.**
- **IF YOU JAM THE MACHINE AND DO NOT DISENGAGE THE P.T.O., IT CAN DAMAGE THE MACHINE. THIS DAMAGE CAN BE COSTLY AND IT MAY NOT BE COVERED UNDER WARRANTY. FOR THIS REASON, IT IS IMPORTANT THAT YOU IMMEDIATELY DISENGAGE THE P.T.O. IF THE MACHINE BECOMES JAMMED.**
- **ONLY YOUR OPERATOR EXPERIENCE WILL TELL YOU HOW FAST TO FEED MATERIAL TO BE PROCESSED.**
- **CHECK TO SEE THAT THE FLYWHEEL WILL TURN FREELY BEFORE YOU START THE SHREDDER/CHIPPER.**
- **VISUALLY CHECK CHIPPER KNIFE FOR DAMAGE EACH TIME YOU USE YOUR SHREDDER/CHIPPER.**
- **CHECK KNIFE CONDITION, WEAR PLATE CONDITION, GAP SETTING AND THE NUTS AND BOLTS THAT HOLD THE KNIFE IN PLACE FOR TIGHTNESS EVERY 8-10 HOURS OF OPERATION.**
- **DO NOT ALLOW PROCESSED MATERIAL TO BUILD UP WITHIN 3" OF DISCHARGE CHUTE OPENING. MOVE SHREDDER/CHIPPER OR PILE AS NEEDED. FAILURE TO DO THIS COULD RESULT IN UNNECESSARY JAMMING OF THE MACHINE.**
- **TO MOVE PILE OF PROCESSED MATERIAL, USE SPADE, RAKE, OR LONG HANDLE TOOL. NEVER USE YOUR HANDS OR FEET!**

SECTION V - MAINTENANCE AND STORAGE

IMPORTANT: The knife should be checked for sharpness and the bolts attaching them to the flywheel for tightness every 8-10 hours of operation.

IMPORTANT: Every time you perform maintenance or any kind of service or check on the knife, be sure to check the gap between the knife and wear plate for proper setting.

If the cutting mechanism strikes any foreign object or if your machine should start making an unusual noise or is vibrating, stop the engine and disconnect the P.T.O shaft before you:

- a. Inspect and examine for damage.
 - b. Repair or replace any damaged parts before restarting and operating the machine.
1. When not in use, your shredder/chipper should be stored out of the reach of children.
 2. After every 8 hours of operation, lubricate the chipper side and drive side bearings. To do this, wipe all dirt, etc., from the grease fittings with a clean cloth, then apply no more than 3 shots of quality general-purpose grease with a hand-pumped grease gun. Over lubrication can also damage bearings. Also, check the bearing collar set screws regularly to be sure they are tight. If they are loose, reset them with Loctite 243, obtainable at any hardware store.
 3. When the steel chipping knife needs replacing or sharpening, refer to the section on removal, sharpening and re-installation.
 4. Care must be exercised when sharpening the knife to maintain the correct bevel and a straight edge. Refer to sharpening directions. When you install a knife, the clearance between the knife and wear plate must be checked and set. This clearance or gap should be set to 1/16" (see figure 1).

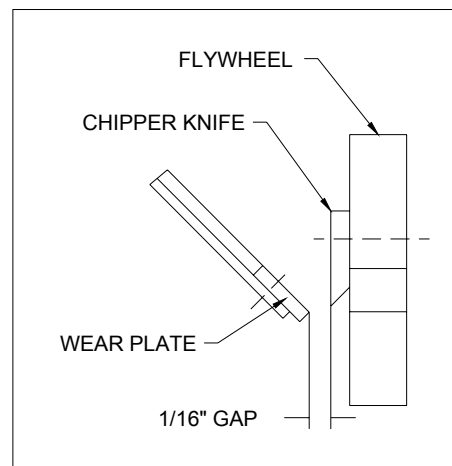

Figure 1

5. To adjust this clearance, loosen the three 1/4" nuts and bolts holding the wear plate in place. The wear plate can be slid up or down (in or out) to achieve the correct gap setting. Tighten the nuts and bolts when the wear plate is in the correct position. Be certain the flywheel rotates without hitting anything before starting the chipper.
6. If the gap between the wear plate and the knife is not set correctly, you will have excessive vibration when chipping and the blade will seem to be dull. This should be checked every 8-10 hours of operation.
7. If at any time it becomes necessary to disassemble the chipper for repairs, the chipper disk must be re-installed in exactly the same position on the rotor shaft.

REMOVAL, SHARPENING AND RE-INSTALLATION OF CHIPPER KNIFE

HOW TO REMOVE THE KNIFE

- Stop the tractor engine and disengage the P.T.O. driveshaft.
- Open the access cover on the chipper basic machine.
- Rotate the chipper disk until the three countersunk screws attaching the knife to the flywheel are visible through the access door.
- Clean out the heads of the allen screws with an awl or sharp tool.
- Insert a 3/16" allen wrench into the heads of the screws.
- While applying pressure with the allen wrench, apply heat from a propane torch to the screws to break loose the Loctite on the screws.
- Remove the heat once the screws have loosened.
- Remove all three allen screws in this manner.

KNIFE SHARPENING

- You should never attempt to sharpen the chipper knife freehand.
- It is extremely important that the 45-degree angle be maintained consistently for proper performance.
- The chipper knife should be taken to a machine shop for proper sharpening.
- Excessive heat generated during the sharpening process will damage knives and weaken the metal. Be sure the knife is not overheated.

KNIFE INFORMATION

- The chipper knife should be checked routinely for sharpness.
- Using a dull knife will decrease performance and cause excessive vibration that will cause damage to the shredder/chipper.
- How many times a knife can be sharpened is determined by how much material needs to be taken off to sharpen or to compensate for dents or gouges.
- A new chipper knife has 5/16" measurement between the short side bevel edge and the knife mounting holes. See figure 2.

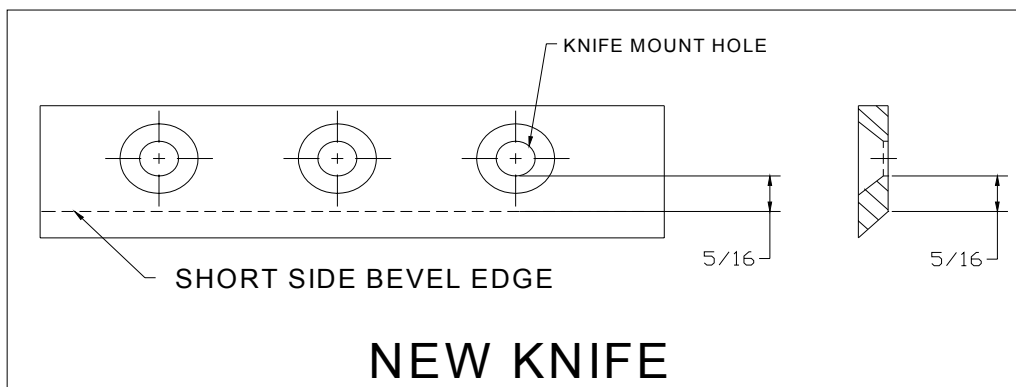

Figure 2

- The knife should never be sharpened to the extent that more than 3/32" is taken off this measurement.
- Once this measurement is below 7/32" (see figure 3) the knife should be replaced.
- If you are unable to remove dents or gouges with these guidelines, replace the knife.

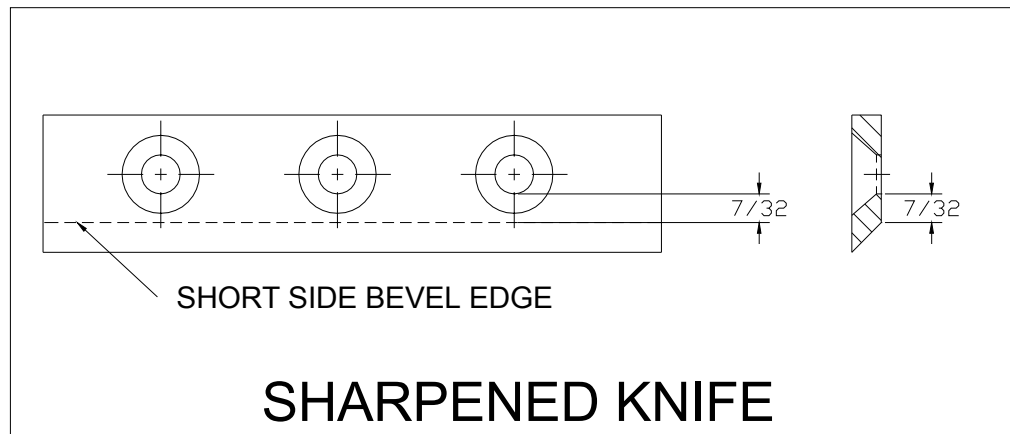

Figure 3

KNIFE INSTALLATION

- Clean chipper disk where knife is going to be attached.
- Visually inspect the chipper disk slot and knife mounting area and be sure they are clean and that the knife will be able to mount flush against the chipper disk.
- Visually inspect and clean the knife.
- Apply Loctite 243 to the screws that hold the knife in place.
- Hand tighten the knife to the chipper disk. If you are installing a new knife, use the new hardware that comes with the knife when attaching it to the chipper disk.
- Tighten the center bolt.
- Tighten the outer bolt.
- Tighten the inner bolt.
- Double-check all three for tightness one more time.

WEAR PLATE

- The wear plate should have a square edge and be free of dents or gouges.
- The wear plate can be sharpened by hand, but as with the knife, do not overheat during the sharpening process. This will change the characteristics of the steel and it should be replaced.
- Check the gap between the knife and wear plate every time any adjustments are done to either piece, or every 8-10 hours of operation.

AFTER ANY BLADE OR WEAR PLATE MAINTENANCE OR ADJUSTMENT, ROTATE THE CHIPPER DISK BY HAND. WATCH AND LISTEN CAREFULLY FOR ANY UNUSUAL NOISES, CLICKING OR VIBRATION. IF ANY OF THESE ARE DETECTED, INSPECT THE MACHINE FOR DAMAGE, REPAIR OR REPLACE ANY DAMAGED PARTS AND CHECK FOR ANY LOOSE PARTS AND RETIGHTEN.

KNIVES MUST BE CHECKED AND MAINTAINED!

KNIVES MUST BE SHARP!

BE SURE TO REINSTALL THE KNIFE CORRECTLY AND DOUBLE CHECK FOR TIGHTNESS!

HAMMERS

When the hard steel hammers of the rotor assembly become dull or round on the cutting edge, they may be rotated or reversed. **These hammers have four cutting edges that may be used before replacement is necessary.** To reverse the hammers proceed as follows.

- Remove belt guard.
- Remove round cover plate from behind belt guard.
- Remove shredder hopper.
- Remove the top plate.
- Turn rotor assembly until hammer rod is facing up.
- Turn hammer rod until small end of groove pin is facing up.
- Drive the groove pin from the hammer rod with a punch.
- Remove hammer rod through access hole on side of machine.
- Reverse hammers and reinstall with spacers on hammer rod.
- Replace old groove pin with new groove pin.

NOTE: Be sure the hammers and spacers are reinstalled in exactly the order in which they were removed. Refer to the rotor assembly drawing for the correct order.

TROUBLESHOOTING

Symptom	Problem	Correction
Belt burns. Rotor won't turn.	Rotor is jammed or stopped.	A. Immediately stop engine. B. Disconnect drive shaft. C. Remove screen & clean out shredder chamber. D. Turn rotor by hand to be sure it turns freely. E. Check belt tension.
Shredding & chipping action seems too slow or rotor stalling.	Engine speed is too slow. Belts are slipping.	Make sure P.T.O. is at 540 RPM. Check for loose or missing belts & tighten.
When chipping, branch seems to vibrate excessively & "hammers" hands.	Knives are dull. Gap between blade & wear plate is too large.	Remove blade & sharpen - be sure to maintain same bevel of 45 degrees. Adjust gap as per instructions.
Machine has excessive vibration.	Rotor is out of balance.	Check rotor carefully to see if hammers or spacers are missing. Replace any damaged or broken hammers.
Chipper knives move over and are striking chipper side plate.	Taper lock bushing is loose. Set screws in rotor shaft bearings are loose or missing.	If key in taper lock bearing is too deep, file key to seat properly. Reset the proper blade gap & tighten set screws.
Products build-up in shredding chamber.	Excessive wear on hammers.	Replace or reverse hammers.

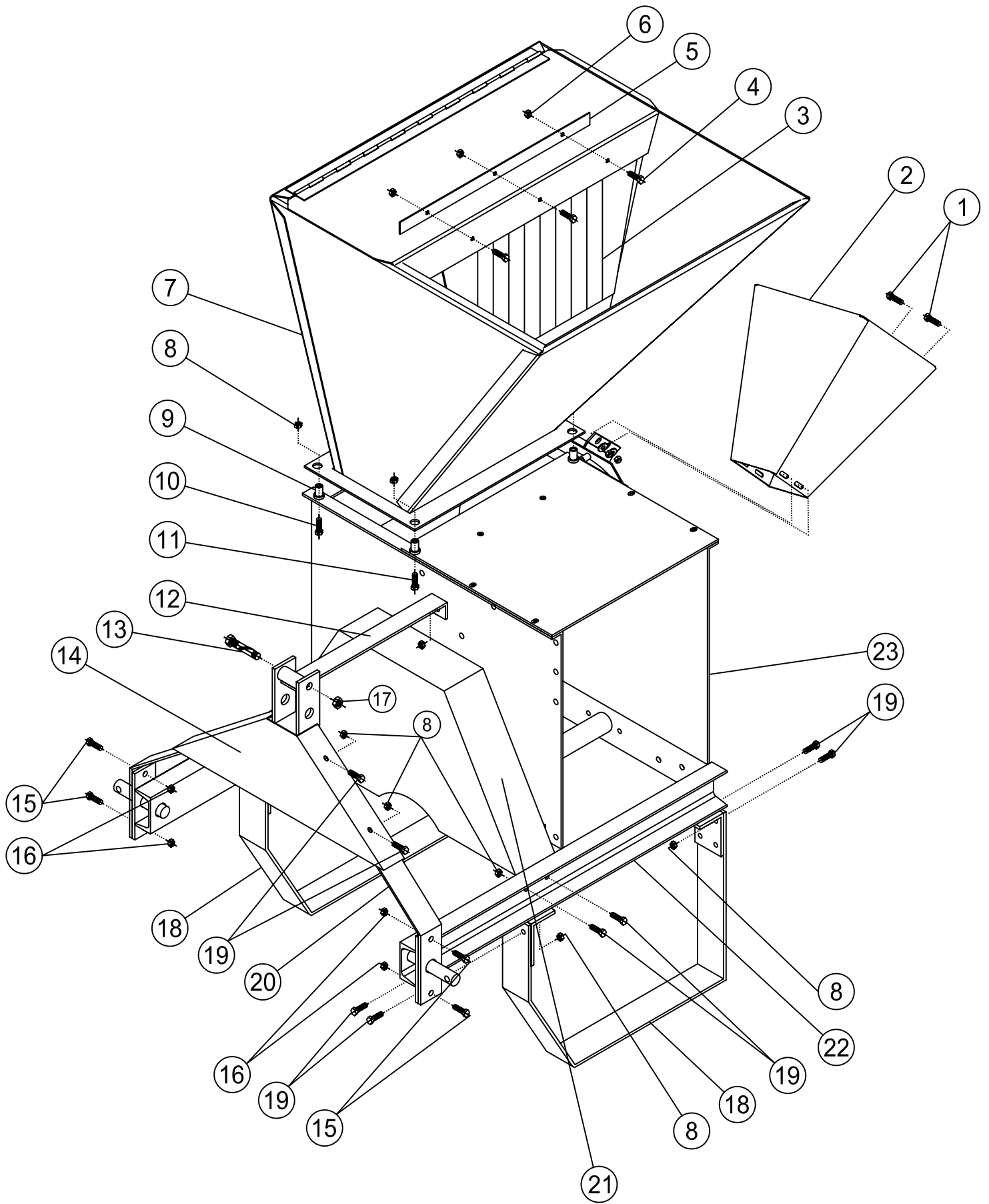

PARTS LIST

ITEM #	PART #	QTY	DESCRIPTION
1	090-0462	4	5/16-18 X 3/4" CARRIAGE BOLT
2	913-0380	1	CHIPPER HOPPER KIT
3	911-0034	1	SHREDDER HOPPER BLOW BACK GUARD
4	090-0012	3	1/4-20 X 3/4" HHCS
5	911-0049	1	BLOW BACK GUARD MOUNT BAR
6	090-0470	3	1/4-20 NYLOCK NUT
7	911-0028	1	SHREDDER HOPPER WELDMENT
8	090-0460	20	5/16-18 NYLOCK NUT
9	500-0068	4	VIBRATION DAMPENER
10	090-0089	2	5/16-18 X 1-1/4" HHCS
11	090-0090	2	5/16-18 X 1-1/2" HHCS
12	911-0302	1	UPPER SUPPORT WELDMENT
13	090-0370	1	1/2-13 X 3" HHCS
14	911-0296	1	CENTER BRACE
15	090-0110	4	3/8-16 X 1" HHCS
16	090-0461	4	3/8 NYLOCK LOCKNUT
17	090-0050	1	1/2-13 GRIPCO LOCKNUT
18	911-0294	2	LEG
19	090-0088	16	5/16-18 X 1" HHCS
20	911-0295	2	TPH MOUNT BRACKET
21	911-0300	1	BELT GUARD WELDMENT
22	911-0293	1	FRAME WELDMENT
23	911-0150	1	BASIC MACHINE

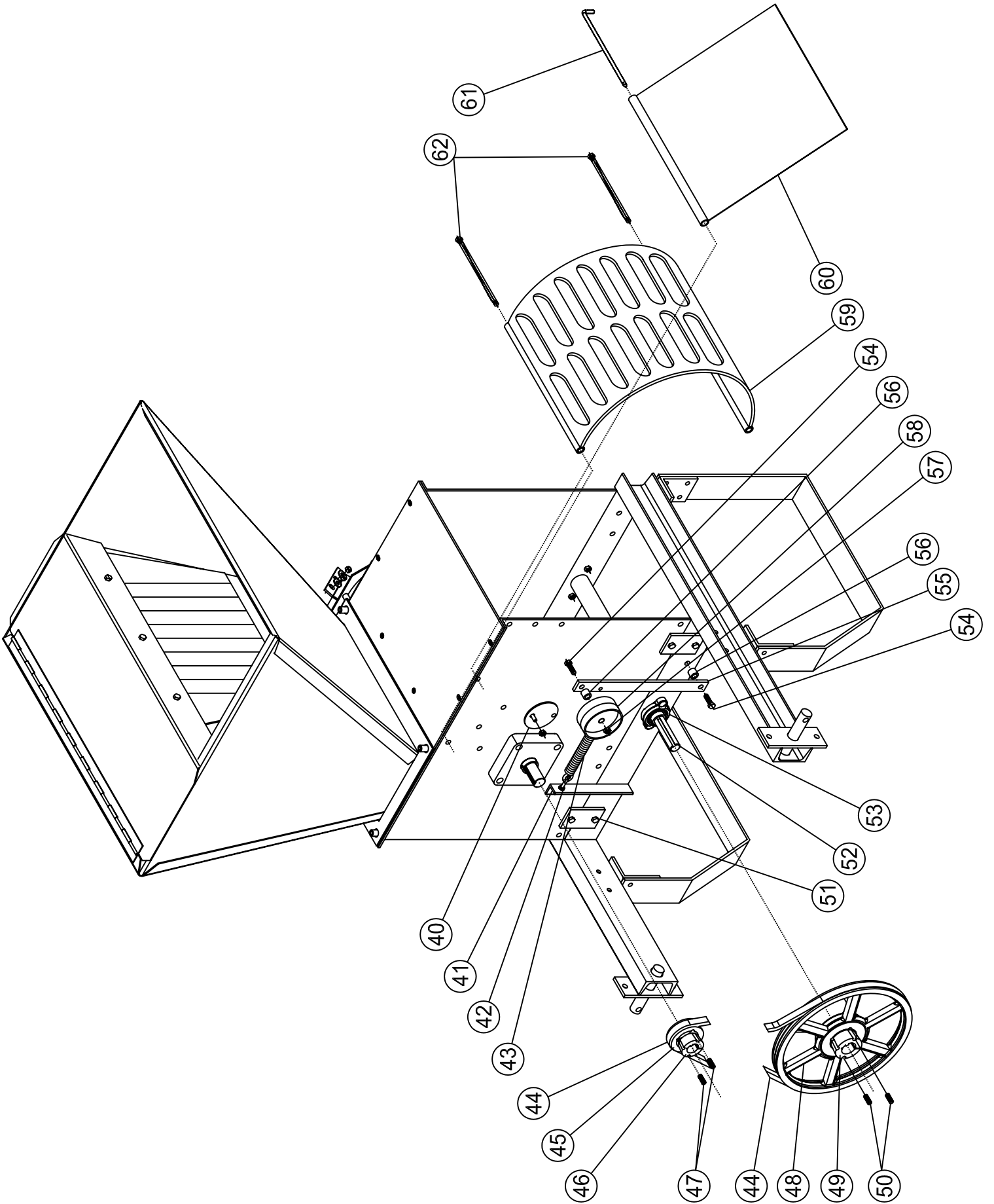

PARTS LIST

40	900-0040	1	COVER PLATE
41	913-0302	1	SPRING MOUNT BRACKET
42	090-0411	1	1/4-20 X 2-1/2" EYE BOLT
43	030-0329	1	SPRING
44	030-0181	1	BELT
45	030-0180	1	3 GROOVE 3.65" SHEAVE
46	030-0167	1	1-7/16" TAPER LOCK BUSHING
47	020-0001	2	3/8-16 X 5/8" SET SCREWS
48	030-0179	1	3 GROOVE 14" SHEAVE
49	030-0489	1	1" TAPER LOCK BUSHING
50		2	1/2-13 X 1/2" SET SCREWS
51	911-0206	4	MOUNT BAR
52	911-0297	1	LOWER SHAFT
53	030-0055	2	1" BEARING
54	090-0113	2	3/8-16 X 1-3/4" HHCS
55	911-0298	1	IDLER ARM
56	900-0092	2	SPACER
57	090-0461	2	3/8-16 NYLOCK NUT
58	909-0016	1	IDLER SHEAVE
59	911-0054	1	SCREEN
60	911-0033	1	BAFFLE
61	911-0036	2	BAFFLE ROD
62	911-0050	2	3/8-16 X 15" HHCS

911-0150
BASIC ASSEMBLY

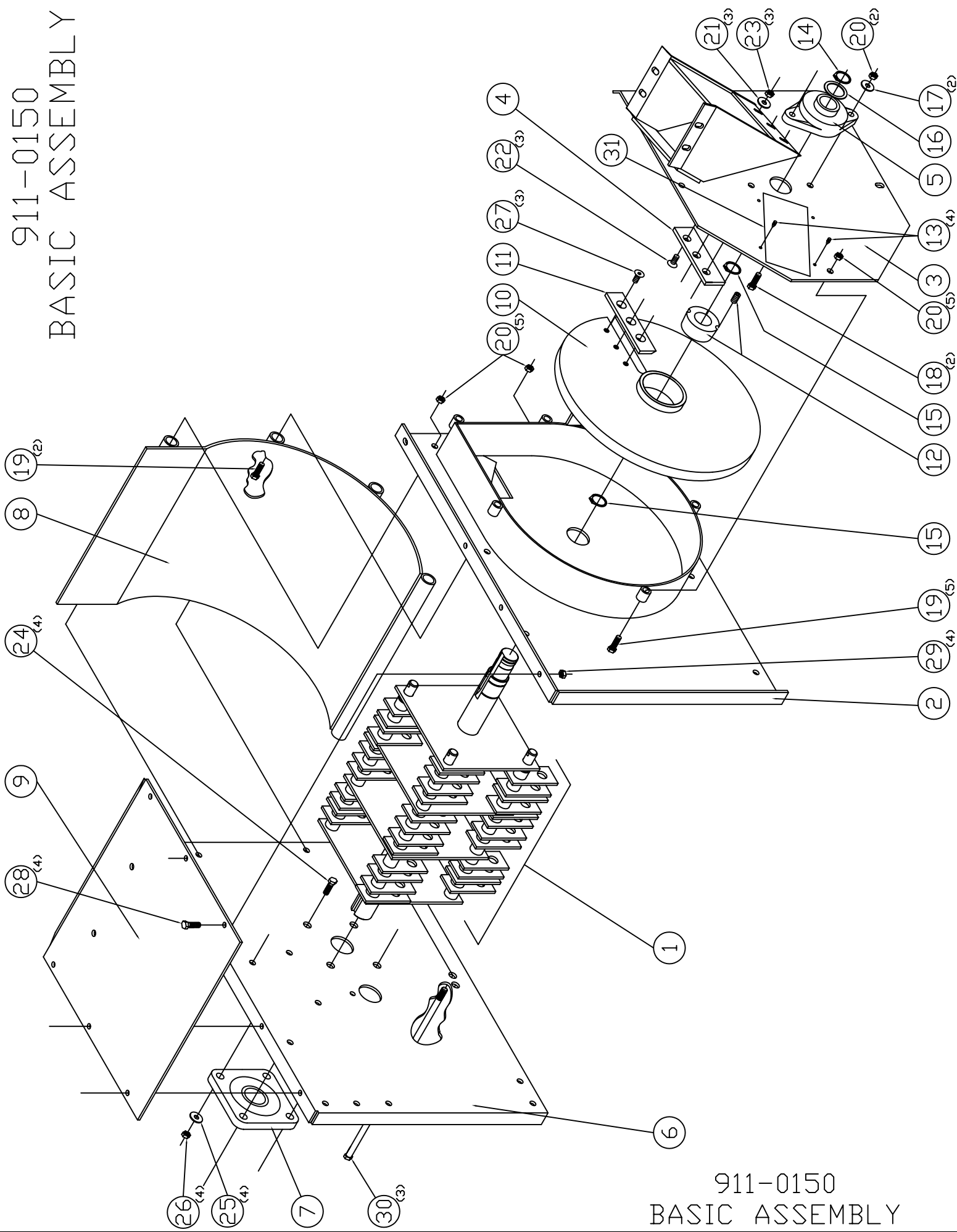

911-0150
BASIC ASSEMBLY

911-0064 ROTOR ASSEMBLY

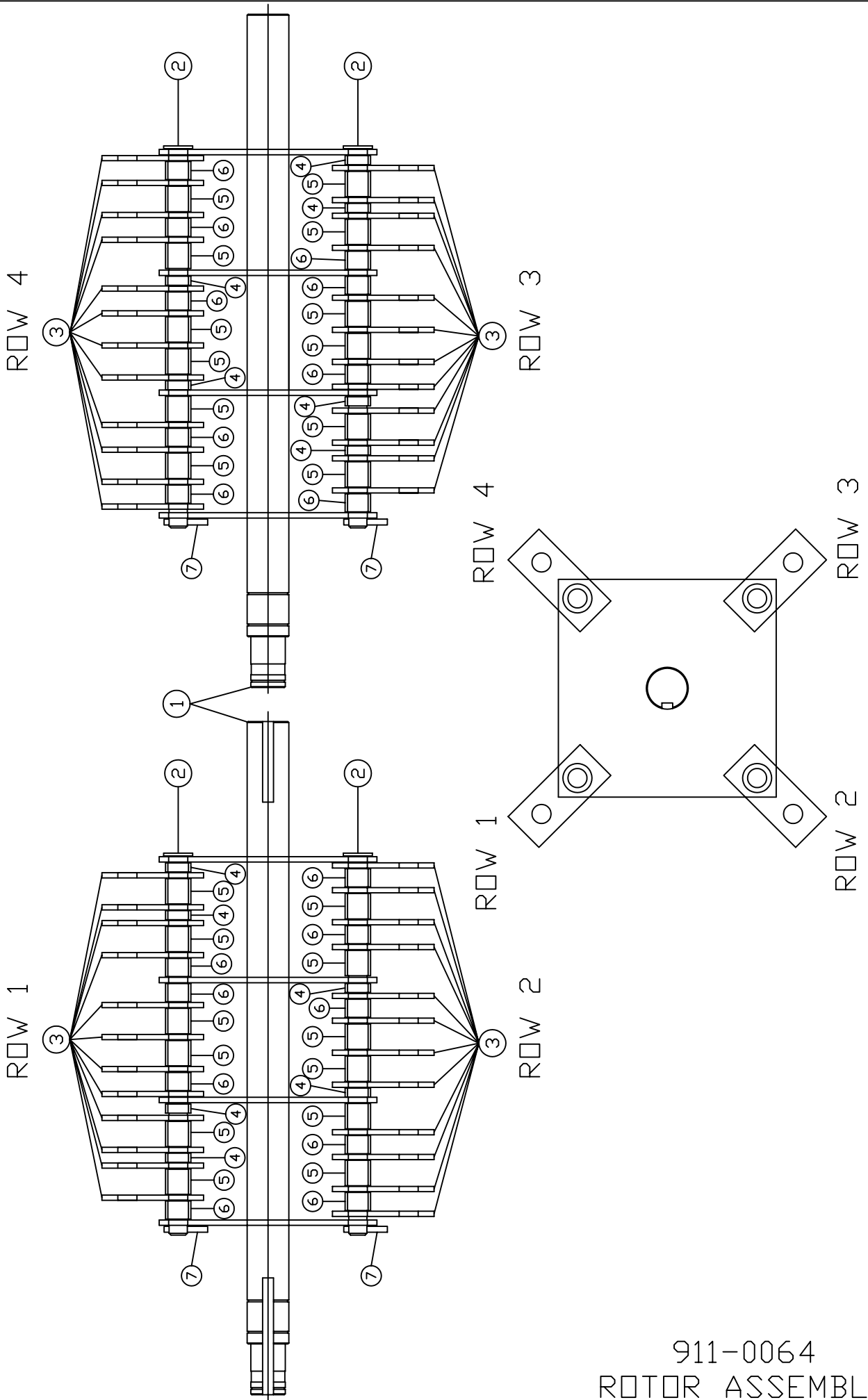

911-0150 BASIC MACHINE

ITEM #	PART #	QTY.	DESCRIPTION
1	911-0064	1	ROTOR ASSY W/HAMMERS
2	911-0152	1	CHIPPER SIDE PLATE WLDMNT
3	911-0268	1	CHIPPER CHUTE PLATE WELDMENT
4	913-0326	1	WEAR PLATE
5	030-0279	1	1 3/16" 2 BOLT BEARING
6	911-0151	1	DRIVE SIDE PLATE
7	030-0166	1	4 BOLT BEARING 1 7/16" BORE
8	911-0003	1	SCROLL WELDMENT
9	911-0026	1	TOP PLATE
10	911-0267	1	CHIPPER DISK – COMPLETE WITH KNIFE
11	030-0500	1	CHIPPER KNIFE
12	030-0167	1	1610 x 1 7/16" ID TAPER LOCK BUSHING
13	090-0162	4	#10-32 X 3/8 SELF TAPPING SCREW
14	030-0117	1	RETAINING RING - 1 3/16"
15	030-0171	2	1 7/16" RETAINING RING
16	090-0024	1	1.565 OD X 1.192 ID X .050 THK
17	090-0233	2	5/16"USS FLATWASHER PLTD
18	090-0111	2	3/8-16 X 1-1/4 HHCS
19	090-0016	7	3/8-16 X 1 1/2 HHCS GR5 - BLACK
20	090-0049	12	3/8-16 GRIPCO LOCKNUT GR B PLT
21	090-0245	3	1/4 SAE FLATWASHER - BLACK
22	090-0257	3	1/4-20 X 1" SOCKET FLAT HD CAP
23	090-0470	3	1/4-20 NYLOK LOCKNUT PLTD
24	090-0463	4	1/2-13 X 1 1/2 HHCS GR5 - BLACK
25	090-0351	4	1/2 SPLIT LOCKWASHER PLTD
26	090-0050	4	1/2-13 GRIPCO LOCKNUT GR B PLT
27	090-0413	3	5/16-18 X 1" FLAT HD SOCKET CAP
28	090-0066	4	5/16-18 X 3/4 HHCS GR 5 PLTD
29	090-0048	4	5/16-18 GRIPCO NUT
30	911-0050	3	3/8-16 X 15"LG HHCS PLTD (TIE ROD)
31	913-0210	1	ACCESS COVER

911-0064 ROTOR ASSEMBLY

ITEM #	PART #	QTY.	DESCRIPTION
1	911-0135	1	ROTOR WELDMENT
2	900-0100-4	4	HAMMER ROD
3	500-0008	48	HAMMER
4	500-0010	12	SPACER-5/16"
5	500-0011	24	SPACER-7/8"
6	500-0012	18	SPACER-5/8"
7	030-0153	4	13/64" DIA X 1 1/2" LG DRIVE PIN

COUNTRY HOME PRODUCTS
Megis Road, P.O. Box 25, Vergennes, Vermont 05491

1(800) DR-OWNER (376-9637)