

DR[®] PILOT™ LEAF & LAWN VACUUM

SAFETY & OPERATING INSTRUCTIONS



Model:
PILOT

Serial No. _____

Order No. _____

DR Power Equipment
Toll-free phone: 1-800-DR-OWNER (376-9637)
Website: www.DRpower.com

WARNING

Read and understand this manual and all instructions before operating the DR LEAF and LAWN VACUUM.

Table of Contents

Chapter 1: General Safety Rules..... 3

Chapter 2: Setting Up the DR PILOT™ LEAF and LAWN VACUUM 8

Chapter 3: Operating The DR PILOT™ LEAF AND LAWN VACUUM 24

Chapter 4: Maintaining the DR PILOT™ LEAF and LAWN VACUUM 32

Chapter 5: Troubleshooting 34

Chapter 6: Parts Lists and Schematic Diagrams..... 36

Conventions used in this manual

WARNING

This indicates a hazardous situation, which, if not avoided, could result in death or serious injury.

CAUTION

This indicates a hazardous situation, which, if not avoided, could result in minor or moderate injury.

NOTICE

This information is important in the proper use of your machine. Failure to follow this instruction could result in damage to your machine or property.

OUTDOOR POWER	
MODEL/MODELO/	XXXXXX
MODELE	
SERIAL NO	SERIAL #
N. DE SERIE	
NU DE SERIE	
POWER (KW)	XXXXXX
WEIGHT (KG)	XXXXXX
ITEM #	XXXXXX
MANUFACTURED DATE	XXXXXX
	
COUNTRY HOME PRODUCTS, INC.	
75 MEIGS RD	
VERGENNES, VT 05481	
COUNTRY OF ORIGIN	XXXXXX
	XXXXXX

Serial Number and Order Number

A Serial Number is used to identify your machine and is located on the Serial Number Label on your machine. An Order Number is used to check and maintain your order history and is located on the upper left portion of your packing slip. For your convenience and ready reference, enter the Serial Number and Order Number in the space provided on the front cover of this manual.

Additional Information and Potential Changes

DR Power Equipment reserves the right to discontinue, change, and improve its products at any time without notice or obligation to the purchaser. The descriptions and specifications contained in this manual were in effect at printing. Equipment described within this manual may be optional. Some illustrations may not be applicable to your machine.

California Proposition 65

 **WARNING**
CANCER AND REPRODUCTIVE HARM - www.P65Warnings.ca.gov.

Chapter 1: General Safety Rules

WARNING

Read this safety & operating Instructions manual before you use the DR LEAF and LAWN VACUUM. Become familiar with the operation and service recommendations to ensure the best performance from your machine. If you have any questions or need assistance, please contact us at www.DRpower.com or call toll-free 1-800-DR-OWNER (376-9637) and one of our Technical Support Representatives will be happy to help you.

Labels

Your DR PILOT™ LEAF and LAWN VACUUM carries prominent labels as reminders for its proper and safe use. Shown below are copies of all the Safety and Information labels that appear on the equipment. Take a moment to study them and make a note of their location on your machine as you set up and before you operate the unit. Replace damaged or missing safety and information labels immediately.

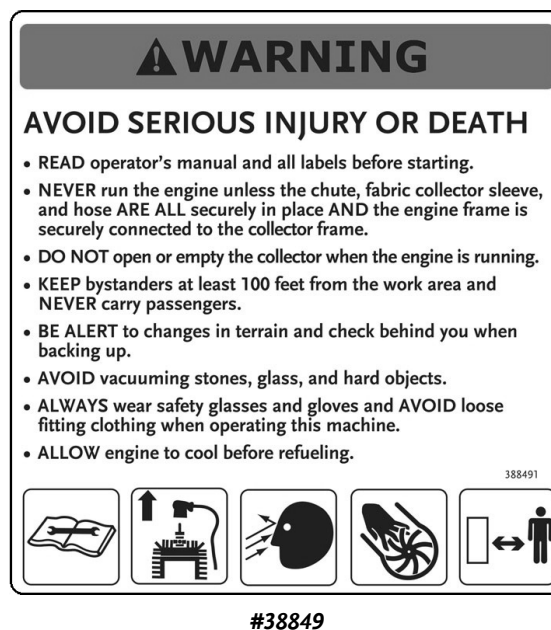
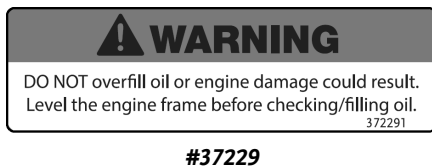

Protecting Yourself and Those Around You

WARNING

This is a high-powered machine, with moving parts operating with high energy at high speeds. You must use proper clothing and safety gear when operating this machine to prevent or minimize the risk of severe injury. This machine can cut and sever parts of your body if they become in contact with the moving impeller blades. Always take the following precautions when operating this machine:

- Always wear protective goggles or safety glasses with side shields while operating either your tractor lawn deck, the vacuum system, or when performing an adjustment on your DR Leaf and Lawn Vacuum to protect your eyes from possible foreign objects thrown from the machine.
 - Avoid wearing loose clothing or jewelry, which can catch on the machine's moving parts.
 - We recommend wearing gloves while using the DR Leaf and Lawn Vacuum. Be sure your gloves fit properly and do not have loose cuffs or drawstrings.
 - Wear shoes with non-slip treads when using your DR Leaf and Lawn Vacuum. If you have safety shoes, we recommend wearing them. Do not use the machine while barefoot or wearing open sandals.
 - Wear long pants while operating the DR Leaf and Lawn Vacuum.
 - Use ear protectors or earplugs rated for at least 20 dba to protect your hearing.
-

Safety for Children and Pets

WARNING

Tragic accidents can occur if the operator is not alert to the presence of children and pets. Children and pets are often attracted to the machine and the vacuuming activity. *Never* assume that children or pets will remain where you last saw them. Always follow these precautions:

- Keep children and pets at least 100 feet from the working area and ensure they are under the watchful care of a responsible adult.
 - Be alert and always turn off the lawn tractor engine and the DR Leaf and Lawn Vacuum engine if children or pets enter the work area.
 - Before and while moving backwards, look behind, and *down* for small children and pets. You cannot see directly behind the collector box.
 - Never allow children to operate the Lawn Tractor or Vacuum.
 - Never allow children or pets to play in the collector. If they become trapped in the enclosure they may be exposed to temperatures similar to leaving a child or pet in a car with the windows closed on a sunny day.
 - Use extra care when approaching blind corners, shrubs, trees, or other objects that may obscure your vision.
-

Safety with Gasoline - Powered Machines

WARNING

Gasoline is a highly flammable liquid. Gasoline also gives off flammable vapor that can be easily ignited and cause a fire or explosion. Never overlook the hazards of gasoline. Always follow these precautions:

- Never run the engine in an enclosed area or without proper ventilation as the exhaust from the engine contains carbon monoxide, which is an odorless, tasteless, and deadly poisonous gas.
 - Store all fuel and oil in containers specifically designed and approved for this purpose and keep away from heat and open flame, and out of the reach of children.
 - Replace rubber fuel lines and grommets when worn or damaged and after 5 years of use.
 - Fill the gasoline tank outdoors with the engine off and allow the engine to cool completely. Don't handle gasoline if you or anyone nearby is smoking, or if you're near anything that could cause it to ignite or explode. Reinstall the fuel tank Cap and fuel container cap securely.
-

Safety with Gasoline - Powered Machines (continued)

WARNING

- If you spill gasoline, do not attempt to start the engine. Move the machine away from the area of the spill and avoid creating any source of ignition until the gas vapors have dissipated. Wipe up any spilled fuel to prevent a fire hazard and properly dispose of the waste.
 - Empty the collector box and allow the engine to cool completely before storing the DR Leaf and Lawn Vacuum in any enclosure. Remember, decomposing material can generate heat and start a fire. Never store the machine with gas in the tank or a fuel container, near an open flame or spark such as a water heater, space heater, clothes dryer, or furnace.
 - Never make adjustments or repairs with the engine running. Shut down the engine, disconnect the spark plug wire, keeping it away from the spark plug to prevent accidental starting, wait 5 minutes before making adjustments or repairs.
 - Never tamper with the engine's governor setting. The governor controls the maximum safe operation speed and protects the engine. Over-speeding the engine is dangerous and will cause damage to the engine and to the other moving parts of the machine. If required, see your authorized dealer for engine governor adjustments.
 - Keep your hands and combustible substances away from the engine when it is hot and clean the engine area after each use.
 - To reduce fire hazard, keep the engine cooling fins and muffler area free of debris build-up such as leaves, grass, oil, grease, or any other combustible material.
 - Never cover the machine while the muffler is still hot.
 - Do not operate the engine with the air cleaner or the carburetor air intake cover removed, except for adjustment. Removal of such parts could create a fire hazard.
 - Do not use flammable solutions to clean the air filter.
 - The muffler and engine become very hot and can cause a severe burn; do not touch.
 - The exhaust area on the engine becomes very hot with use. Allow the engine to cool before doing maintenance or making adjustments.
-

Slope Operation

WARNING

Slopes are a major factor related to tip over accidents, which can result in severe injury. All slopes require caution. If you feel uneasy on a slope, do not vacuum it. Always take the following precautions when using this machine on slopes:

ALWAYS:

- Vacuum up and down the face of slopes, never across. Exercise extreme caution when changing direction on slopes.
- Remove objects such as stones, glass, and metal objects such as cans.
- Watch out for holes, ruts, or bumps. Tall grass can hide obstacles.

NEVER:

- Never vacuum near drop-offs, ditches, or embankments. Your tractor and the vacuum may tip over.
 - Never vacuum on slopes greater than 15 degrees or any excessively steep slopes.
 - Never vacuum on wet slopes. Reduced traction could result in slipping and a possible roll over.
-

General Safety

WARNING

This is a high-powered machine, with moving parts operating with high energy at high speeds. You must operate the machine safely. Unsafe operation can create a number of hazards for you, as well as anyone else in the nearby area. Always take the following precautions when using this machine:

- Never allow people who are unfamiliar with these instructions to use the DR Leaf and Lawn Vacuum.
 - To be safe, do not operate the machine near small children or pets, and never allow children to operate the vacuum. Stop the vacuum engine and tractor engine when another person or pet approaches.
 - Never allow people or pets to ride in the collector box or on the frame.
-

General Safety (continued)

WARNING

- Never run the engine unless the chute, fabric collector sleeve, and hose are all securely in place and the engine frame is securely connected to the main frame.
 - Check behind your DR Leaf and Lawn Vacuum before backing up. You cannot see directly behind the collector box.
 - Never attempt to open or empty the collector while the lawn tractor deck is engaged or the DR Leaf and Lawn Vacuum engine is running. Debris may exit at high velocity as you begin to open the collector.
 - Do not operate in sandy areas where you will vacuum large quantities of sand. Sand will erode the vacuum housing. Check for holes after each use and replace the housing and liner when holes develop.
 - Never operate the machine on slopes greater than 15 degrees.
 - Never tow the DR Leaf and Lawn Vacuum faster than 8 mph.
 - Always shut off the lawn tractor engine and the DR Leaf and Lawn Vacuum engine and disconnect the spark plug wire before attempting to clear any obstructions from the hose.
 - Use the DR Leaf and Lawn Vacuum only in daylight.
 - Never straddle or reach over the engine area at any time.
 - Use only your hands to operate the DR Leaf and Lawn Vacuum engine controls.
 - Do not, under any conditions, remove, bend, cut, fit, weld, or otherwise alter standard parts on the DR Leaf and Lawn Vacuum. Modifications to your machine could cause personal injuries and will void your warranty.
 - Do not alter or tamper with safety devices or shields. Make sure they are in their proper position.
 - While using the DR Leaf and Lawn Vacuum, do not hurry or take things for granted.
 - Never leave the DR Leaf and Lawn Vacuum unattended with its engine running.
 - Do not operate the machine when under the influence of alcohol, drugs, or medication.
-

CAUTION

The DR Leaf and Lawn Vacuum must be operated safely to prevent or minimize the risk of minor or moderate injury. Unsafe operation can create a number of hazards for you. Always take the following precautions when operating this machine:

- Keep in mind that the operator or user is responsible for accidents or hazards occurring to other people, their property, and themselves.
 - Never use the DR Leaf and Lawn Vacuum to vacuum anything but yard waste, such as leaves, grass, small twigs and pine cones.
 - If the machine starts to make an unusual noise or vibration, immediately shut off the engine, disconnect the spark plug wire, and allow all moving parts to come to a complete stop and cool. Inspect for clogging or damage. Clean and repair and/or replace damaged parts.
 - See manufacturer's instructions for proper operation and installation of accessories. Only use accessories approved by DR Power Equipment.
 - Always keep the equipment in a good safe operating condition. Always make certain nuts and bolts are tight and always use the supplied self-locking hardware; do not substitute.
 - For best performance we recommended that you operate your Leaf and Lawn Vacuum in temperatures 40°F and above.
-

A Note to All Users

Under California law, and the laws of some other states, you are not permitted to operate an internal combustion engine using hydrocarbon fuels without an engine spark arrester. This also applies to operation on US Forest Lands. All DR® PILOT™ LEAF and LAWN VACUUMS shipped to California, New Mexico and Washington State are provided with spark arresters. Failure of the owner or operator to maintain this equipment in compliance with state regulations is a misdemeanor under California law and may be in violation of other state and/or federal regulations. Contact your State Park Association or the appropriate state organization for specific information in your area.

No list of warnings and cautions can be all-inclusive. If situations occur that are not covered by this manual, the operator must apply common sense and operate this DR® PILOT™ LEAF and LAWN VACUUM in a safe manner. Contact us at www.DRpower.com or call 1-800-DR-OWNER (376-9637) for assistance.

Chapter 2: Setting Up the DR PILOT™ LEAF and LAWN VACUUM

It may be helpful to familiarize yourself with the controls and features of your DR PILOT™ LEAF and LAWN VACUUM as shown in *Figure 1* before beginning these procedures. If you have any questions at all, please feel free to contact us at www.DRpower.com.

DR PILOT™ LEAF and LAWN VACUUM Controls and Features

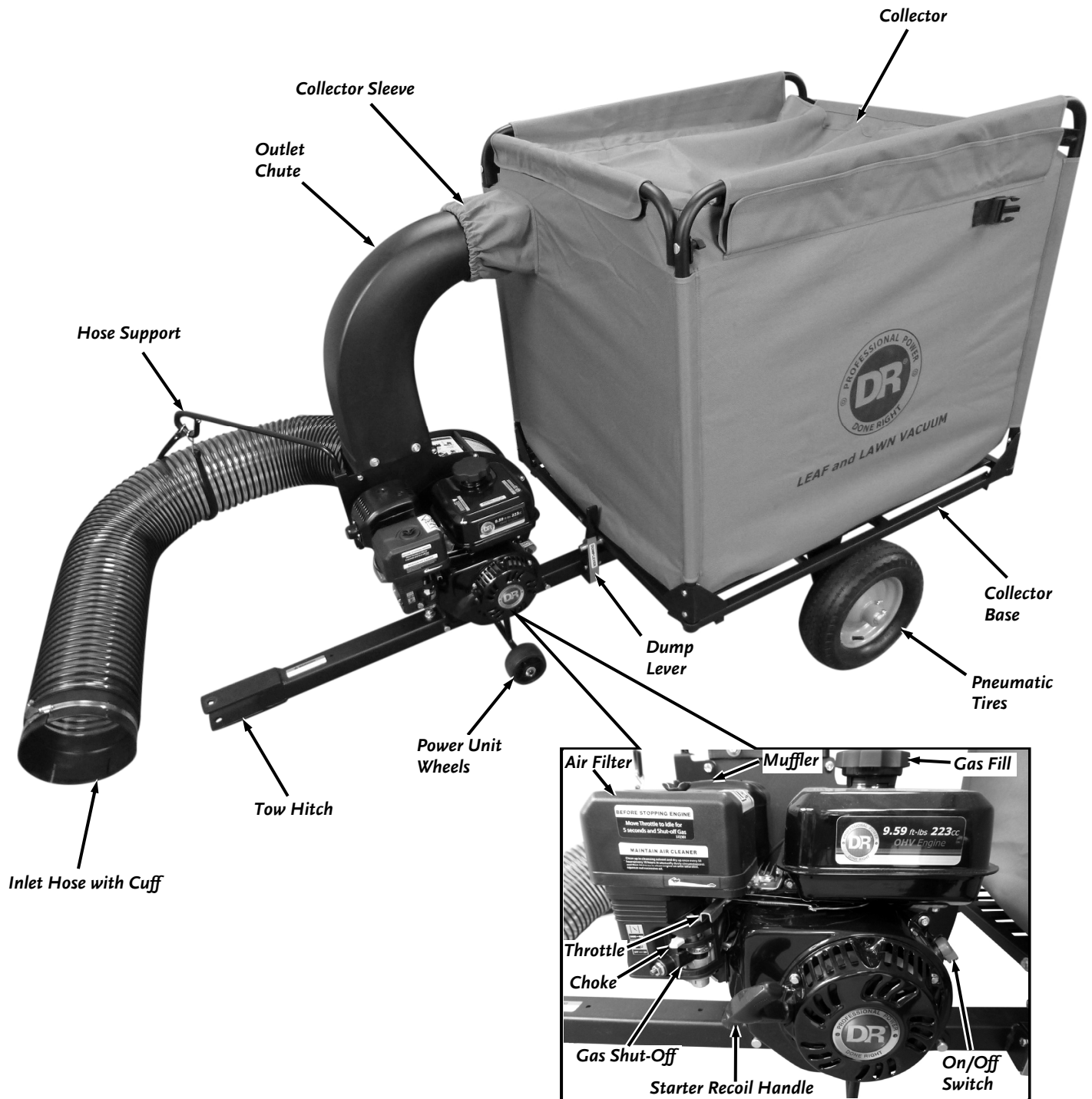

Figure 1

Specifications

Engine	DR Power Equipment R225
Ft-lbs Torque	9.59
Starting	Manual
RPM	3800
Impeller	Steel, 5 Blades w/Serrated Teeth
Weight	13.2 Lbs
Mount	Direct Mount on Tapered Engine Shaft
Vacuum	2038 CFM
Suction	66 MPH
Hose	8" ID x .035" Wall PVC, 72" L
Collector	Over-center Tilt Design w/ Flatbed Base
Volume	27 Cuft, 200 Gallons
Capacity	400 Lbs
Fabric Enclosure	1800 Denier Polyester, Solution Dyed, Bonded PVC Backing
Dump Tilt	55°
Base	Flatbed, Steel
Frame	Welded Steel, 2 Piece Modular Design
Impeller Housing	Steel Scroll (.12" Thick), Sideplate (.12" Thick)
Wheels	Pneumatic 5.30/4.50-8 4 Ply w/ Tube
Quantity	2 (1 Per Side)
Tire Size	14" Diameter x 4.5" Wide
Jack	Optional Accessory
Lawn Mower	12 HP Min Flat Terrain otherwise 14 HP
Lawn Mower Hitch	Pin Hitch 8" to 15" from the Ground
Dimensions	87.8" L x 40.1" W x 52.6" H
Weight	230 Lbs

Assembly Parts Identification

Compare the contents of the Shipping Box with the Parts Supplied lists and Figures 2 thru 6 below. If there are any questions contact us at www.DRpower.com or call 1-800-DR-OWNER (376-9637).

Tools and Supplies Needed:

- Two 9/16" Wrenches
- Needle Nose Pliers
- Two 1/2" Wrenches
- Two 3/4" Wrenches

Parts supplied in Shipping Box (Figure 2):

Item #	Part #	Description	Qty
1	38858	Chute, Impeller Outlet	1
2	33797	Clamp, Hose, 8", Thumbscrew	1
3	34248	Cuff, Hose, 8"	1
4	33796	Clamp, Hose, 8", LH Bridge	2
5	33795	Hose, 8"ID x 72" Long, PVC	1
6	38854	Enclosure, Fabric	1
7	38844	Tube, Collector	2
8	34244	Rod, Support Hose	1
9	38866	Batten, FRP, .58" X .12" X 29.4"	4
10	33801	Axle	1
11	38852	Tube Frame, Top Rear	1
12	38851	Tube Frame, Top Front	1
13	33794	Wheel & Tire, 14X 5.3/4.50-8, 4 Ply	2

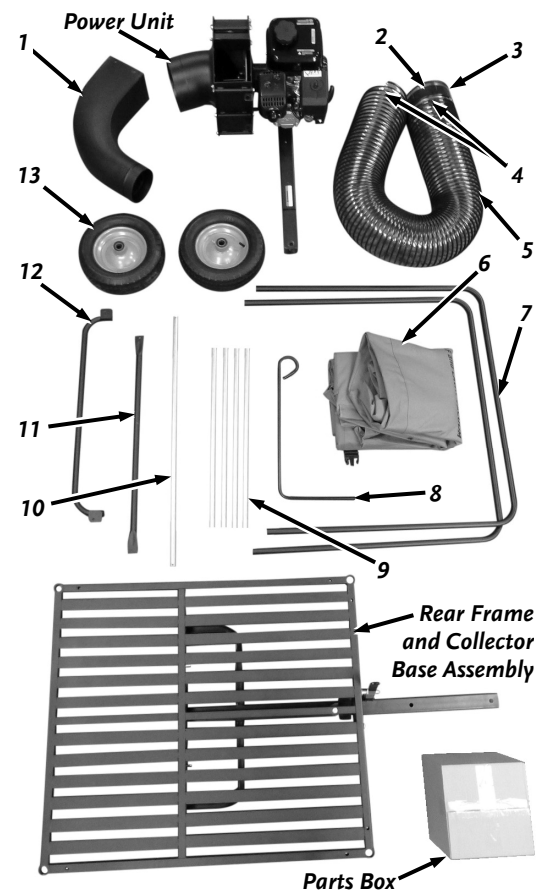

Figure 2



Figure 3

Parts Box (Figure 3):

Item #	Part #	Description	Qty
1	33802	Axle Bracket	2
2	38845	Bracket, Tube, Front, LH	1
	38846	Bracket, Tube, Front, RH	1
3	34247	Strap, Rubber	1
	35042	Hook, Strap	2
4	38860	Knob Set	1
5	35021	Hardware Set, Wheels	1
6	38867	Hardware Set, Power Unit	1
7	37036	Funnel, Oil Flexible (snap together)	1
8	38847	Bracket, Tube, Rear, LH	1
	38848	Bracket, Tube, Rear, RH	1

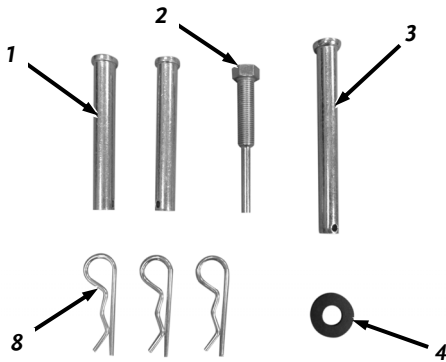

Figure 4

Hardware in Product Package (Figure 4):

Item #	Part #	Description	Qty
1	21154	Pin, Clevis, 1/2" X 3.5"L, ZP	2
2	35037	Bolt, Hex, 7/16-20, Impeller Tool	1
3	18737	Pin, Clevis, 1/2 x 4.5"L, ZP	1
4	18967	Washer, Rubber, 1/2" ID, 1" OD	1
5	35027	Bolt, C-Head, 5/16-18 X 1.75", ZP	4
6	11076	Nut, Nylon Lock, 5/16-18	8
7	13443	Bolt, HCS, 5/16-18 X 1.5", GR5, ZP	8
8	16003	Clip, Pin Hitch, 1/2"-9/16"	3



Figure 5

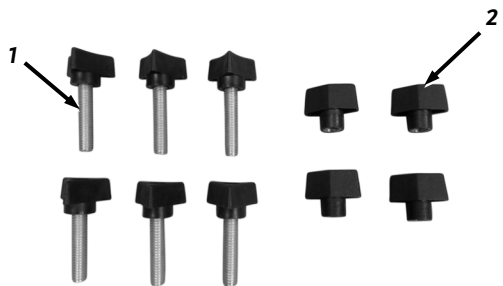

Knob Set (Figure 5):

Item #	Part #	Description	Qty
1	38861	Knob, 3 Prong, 5/16-18 Stud	6
2	35030	Knob, 5/16-18 W/Lock, 1.16 DIA.	4

Wheels Hardware Set (Figure 6):

Item #	Part #	Description	Qty
1	35039	Washer, 1.06" ID X 2" OD X .13", ZP	4*
2	12334	Bolt, HCS, 3/8-16 X 1.75", GR5, ZP	4
3	33333	Nut, Nylon Lock, Flange, 3/8-16	4
4	12685	Pin, Cotter, 3/16" X 1.5"	2

* Only two of the 1.06" ID X 2" OD X .13" Washers will be used for this machine.

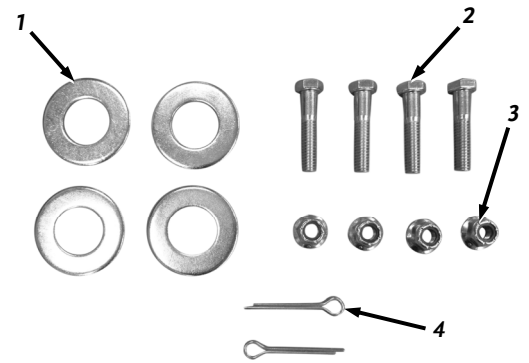

Figure 6

Power Unit Hardware Set (Figure 7):

Item #	Part #	Description	Qty
1	26556	Bolt, HCS, 1/2-13 X 2.75", GR5, ZP	2
2	35023	Bolt, Hex, Flange, 5/16-18 X .75"	4
3	11243	Washer, Lock, 5/16", Split, ZP	4
4	11241	Washer, Flat, 5/16" USS, ZP	4
5	33335	Nut, Nylon Lock, Flange, 1/2-13	2

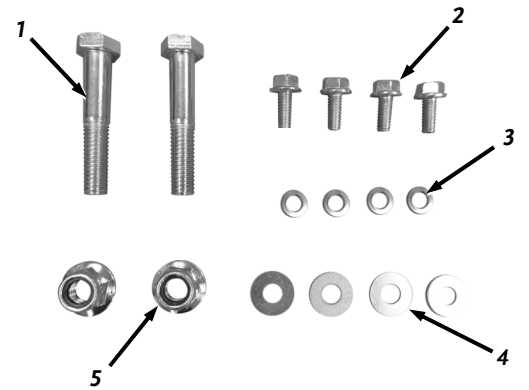

Figure 7

Installing the Wheels

(Use Wheel Hardware Set, see Figure 6)

Tools Needed:

- Two 9/16" Wrenches
- Pliers

1. Position the Rear Frame and Collector Base Assembly upside down (Figure 8).
2. Install the Axle Brackets and loosely secure with the Bolts and Locknuts using two 9/16" Wrenches.
3. Slide the Axle through the Brackets until the same amount sticks out on each side (Figure 9). Do not tighten the hardware until you are finished step 7 on the following page.
4. Slide a Wheel onto the Axle with the Valve Stem facing out and install a 1.06" ID X 2" OD X .13" Washer against the Wheel (Figure 10).

Note: There are four 1.06" ID X 2" OD X .13" Washers in the wheels hardware set. Only two will be used for this machine.

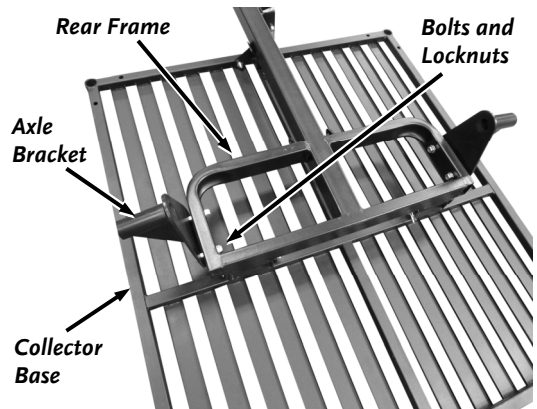

Figure 8

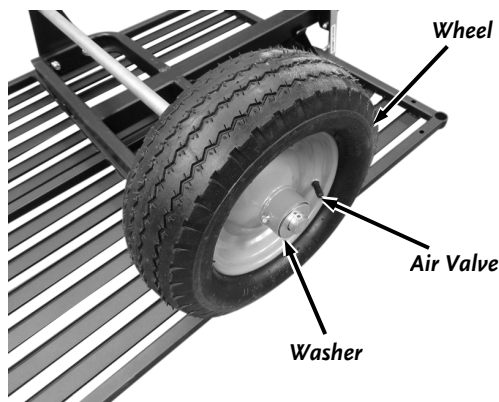

Figure 10

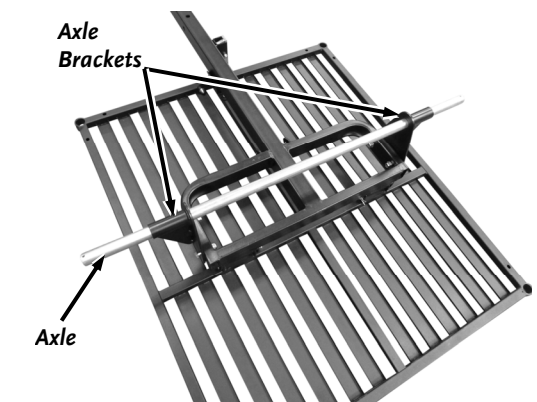

Figure 9

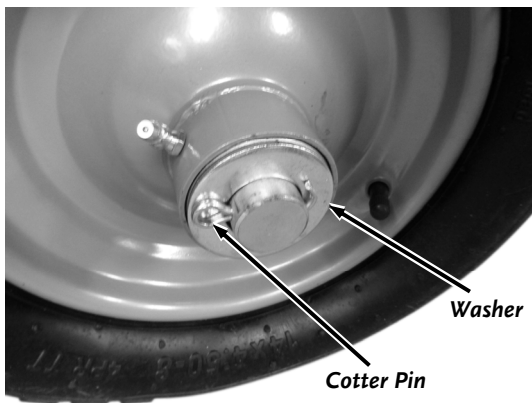

Figure 11

5. Secure the Wheel onto the Axle with a Cotter Pin. Use Pliers to bend the ends of the Cotter Pin to secure the Wheel (**Figure 11**).
6. Repeat for the Wheel on the opposite side.
7. Tighten the Axle Bracket Hardware you installed in step 2.
8. Tip the Frame and Base over onto the Wheels.

Assembling and Installing the Power Unit

(Use Power Unit Hardware Package, see Figure 7)

Tools Needed:

- 1/2" Wrench
- Two 3/4" Wrenches
- Flat Head Screwdriver or 9/32" Wrench

1. Place the Outlet Chute on top of the Impeller Housing (make sure to orient it as shown) and secure with four Bolts, Lock Washers, and Flat Washers using a 1/2" Wrench (**Figure 12**).

CAUTION

We recommend having a helper to attach the Frames together. There is a chance for injury if you attempt alone because the Power Unit is heavy.

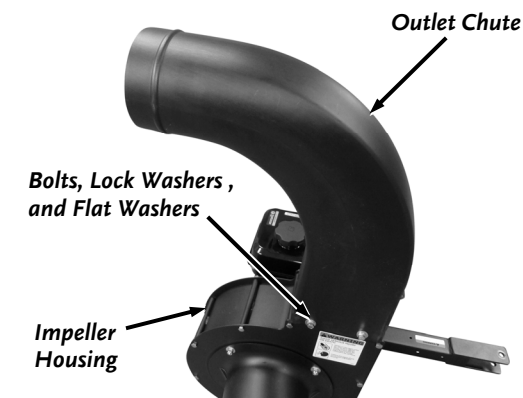

Figure 12

2. Position the Power Unit at the front of the Rear Frame with the Tow Hitch facing forward (**Figure 13**).

Note: Clevis Pins and Hitch Clips needed for the next steps are provided in the Product Package.

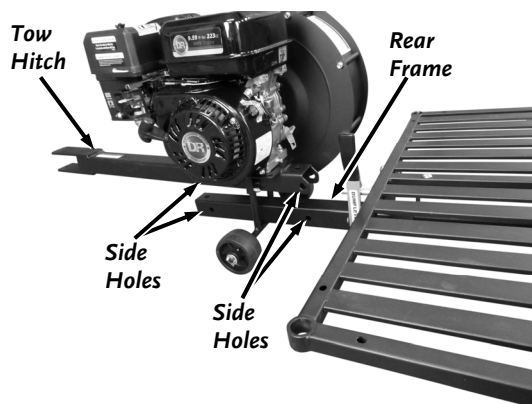

Figure 13

3. Lift the Rear Frame and Power Unit to align the two sets of side holes and insert a 1/2" X 3.5" Clevis Pin into each (**Figure 14**).

4. Secure each Clevis Pin with a Hitch Clip.

5. Place the two 1/2-13 X 2.75" Bolts from underneath up through the two vertical Holes and secure with 1/2-13 Locknuts using two 3/4" Wrenches (**Figure 15**).

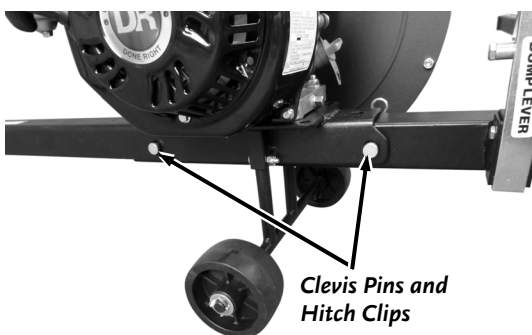

Figure 14

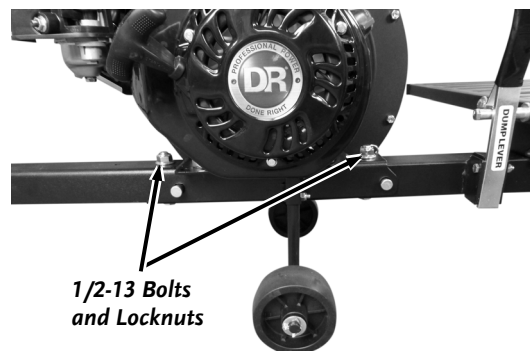

Figure 15

Installing the Inlet Hose

Note: One end of the Inlet Hose has a Cuff that will later attach to your Tractor Deck Adapter. First you will attach the other without a Cuff to your PILOT™ LEAF and LAWN VACUUM Power Unit.

1. Using a Flat Head Screwdriver or 9/32" Wrench, loosen the Hose Bridge Clamp on the end of the Hose, slide the Hose onto the Housing neck, and tighten the Hose Bridge Clamp very tightly (**Figure 16**).
2. Slide the Hose Support into the Bracket holes (**Figure 17**).

Note: Make sure the Hose Bridge Clamp is past the Retaining Bumps on the Housing.

3. Support the Hose with the Rubber Strap by hooking one end into the Support Loop, going under the Hose and securing the other end onto the Support Loop (**Figure 18**).

Assembling the Collector

(Use Bolts and Locknuts from Product Package, see **Figure 4**)

(Use Knob Set, see **Figure 5**)

Tools Needed:

- Two 1/2" Wrenches

1. Unfold the fabric Enclosure and place it onto the Collector base (**Figure 19**). Position the Enclosure with the DR logo facing up and the Enclosure Sleeve positioned at the front right hand corner.

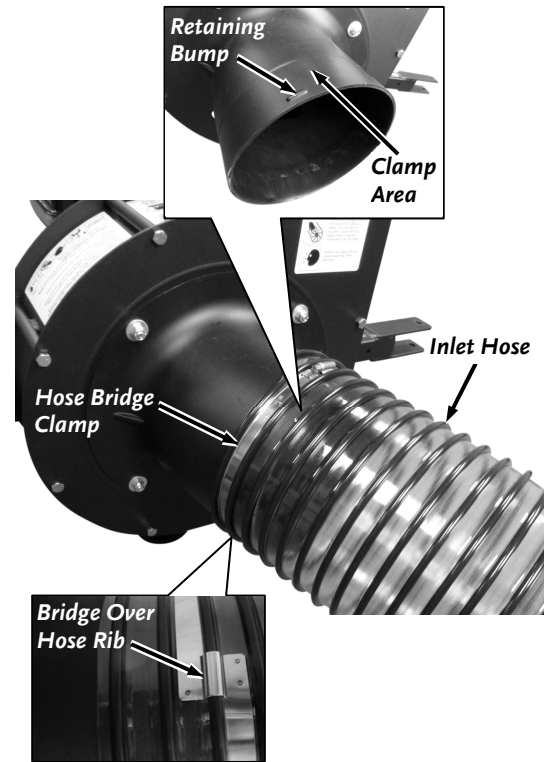

Figure 16

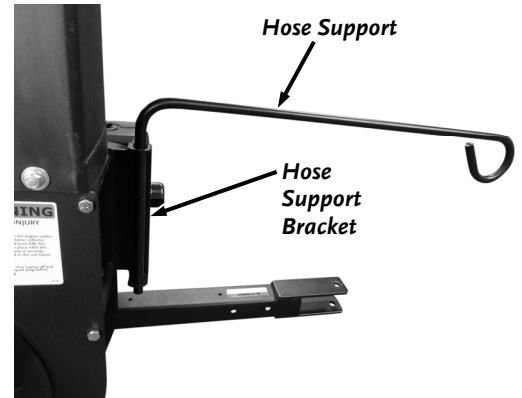

Figure 17

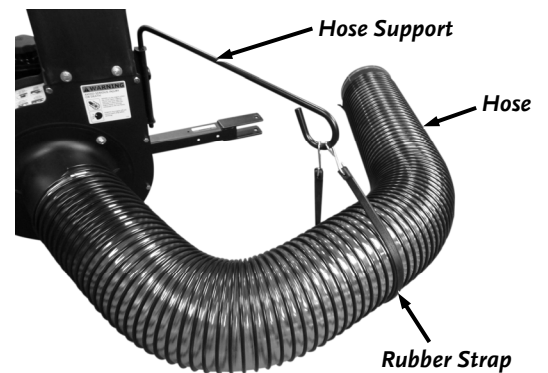

Figure 18

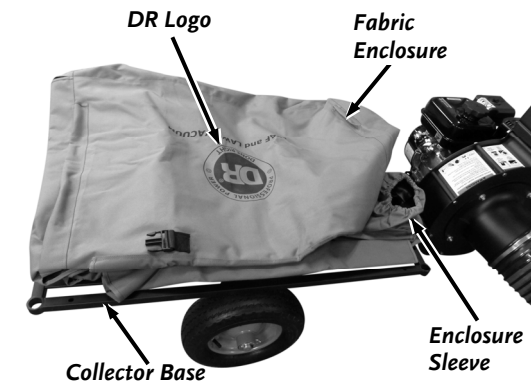

Figure 19

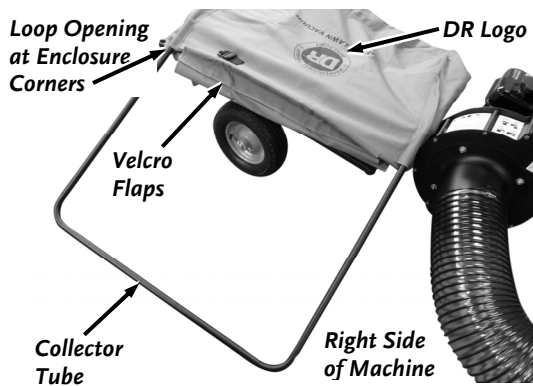

Figure 20

2. Standing on the right side of the machine, insert the ends of the first Collector Tube into the corner loops in the Enclosure (**Figure 20**). Note the orientation of the DR Logo and top Velcro Flaps.
3. Push the Tubes through until they stick out the other end approximately 5-1/2" (**Figure 21**).
4. Flip the Enclosure over (**Figure 22**) so the other side is facing up (**Figure 23**).
5. Go to the left hand side of the machine (**Figure 24**).
6. Insert the ends of the second Collector Tube into the corner loops in Enclosure.

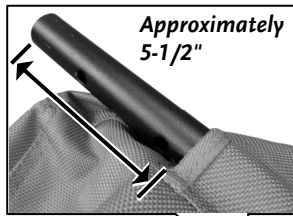

Figure 21



Figure 23



Figure 22

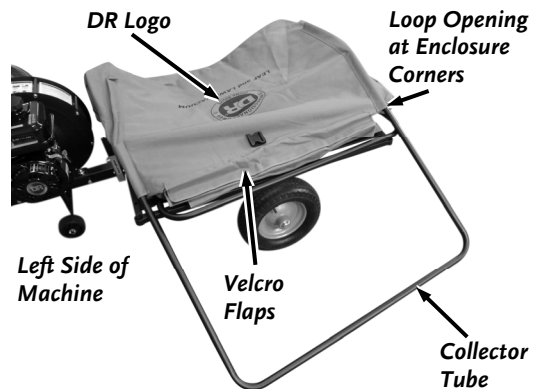

Figure 24

7. Push the Tubes through until they stick out the other end approximately 5-1/2" (**Figure 25**).

8. Go to the right hand front corner of the machine (**Figure 26**). Confirm that the Sleeve of the Fabric Enclosure is oriented as shown and the DR Logo is oriented as shown.

Note: The right and left hand Front Tube Brackets must be mounted correctly at the end of the Collector Tubes. Pay close attention to the orientation in the Figures to verify that you have the correct Bracket.

9. Position the right hand (RH) Front Tube Bracket on the top Tube as shown and secure with two Bolts and Locknuts using two 1/2" Wrenches (**Figure 27**). Do not fully tighten. Ensure the fabric doesn't get pinched under the Bracket.

10. Position the left hand (LH) Front Tube Bracket on the bottom Tube as shown and secure with two Bolts and Locknuts using two 1/2" Wrenches (**Figure 28**). Do not fully tighten. Ensure the fabric doesn't get pinched under the Bracket.

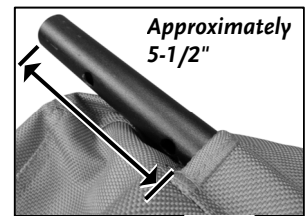

Figure 25



Figure 26

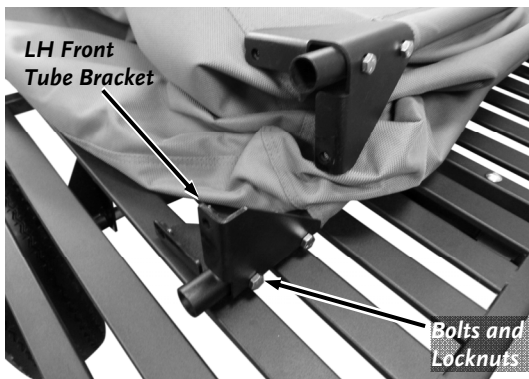

Figure 28

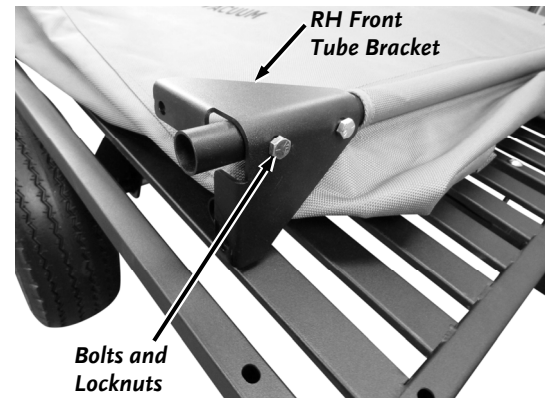

Figure 27

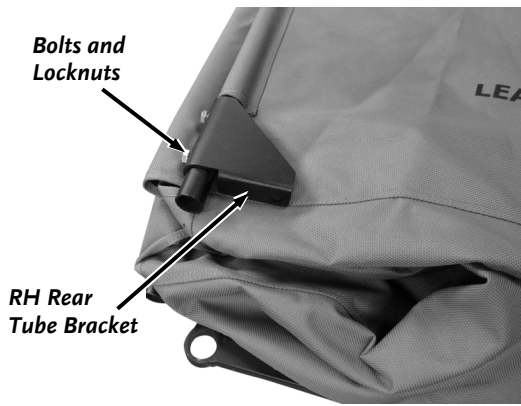

Figure 29

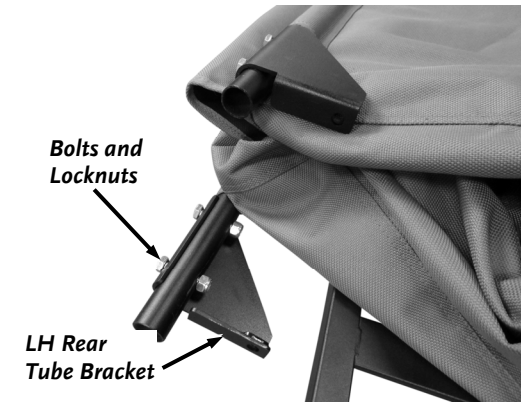

Figure 30



Figure 31

Note: The right and left hand Rear Tube Brackets must be mounted correctly at the end of the Collector Tubes. Pay close attention to the orientation in the Figures to verify that you have the correct Bracket.

11. At the rear of the Enclosure, position the right hand (RH) Rear Tube Bracket on the top Tube as shown and secure with two Bolts and Locknuts using two 1/2" Wrenches (Figure 29). Do not fully tighten. Ensure fabric doesn't get pinched under the Bracket.
12. Position the left hand (LH) Rear Tube Bracket on the bottom Tube as shown and secure with two Bolts and Locknuts using two 1/2" Wrenches (Figure 30). Do not fully tighten. Ensure fabric doesn't get pinched under the Bracket.
13. Lift the Enclosure and insert the ends of the Collector Tubes into the holes at the corners of the Collector Base (Figure 31).
14. Secure the rear Tube Brackets to the Collector Base with one Hand Knob with Stud for each Bracket (Figure 32). Do not tighten fully.
15. Secure the front Tube Brackets to the Collector Base with two Hand Knobs with Studs for each Bracket (Figure 33). Do not tighten fully.

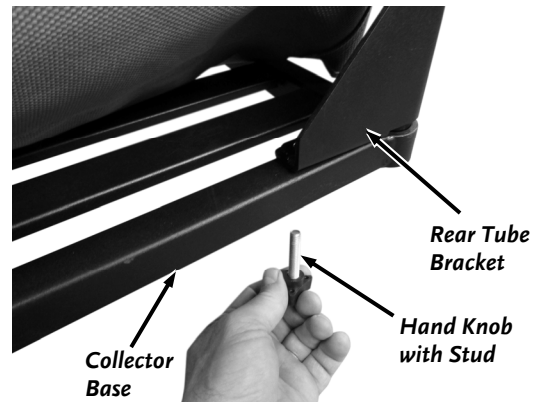

Figure 32

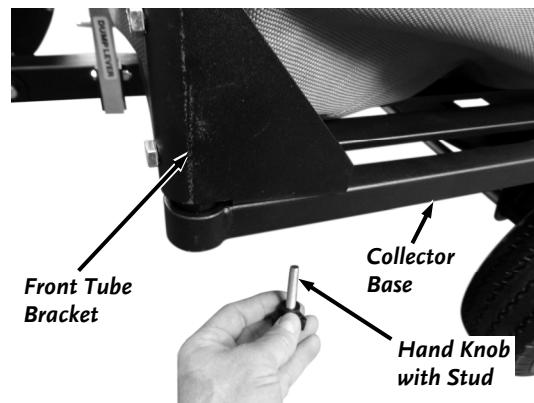

Figure 33

16. Install the top front Tube Frame to the side Tube Frames and secure with two C-Head Bolts and Knobs (**Figure 34**).
 17. Slide the Top Rear Tube Frame through the Enclosure Loop and secure to the Side Tube Frames with two C-Head Bolts and Hand Knobs with threads (**Figure 35**).
- Note:** The round Tube portion of the Top Rear Tube Frame is offset from the flat ends. Install so the offset is facing out towards the back.
18. Adjust the enclosure corner loops so that there is about 1/2" of tube showing above the tube brackets (**Figure 36**).
 19. Open up the side Loops by pulling at the Velcro closures to separate them (**Figure 37**).
 20. Fold the Inner Flap over the side Tube Frame and secure the Velcro next to the Outer Flap (**Figure 38**). Repeat for the other side.

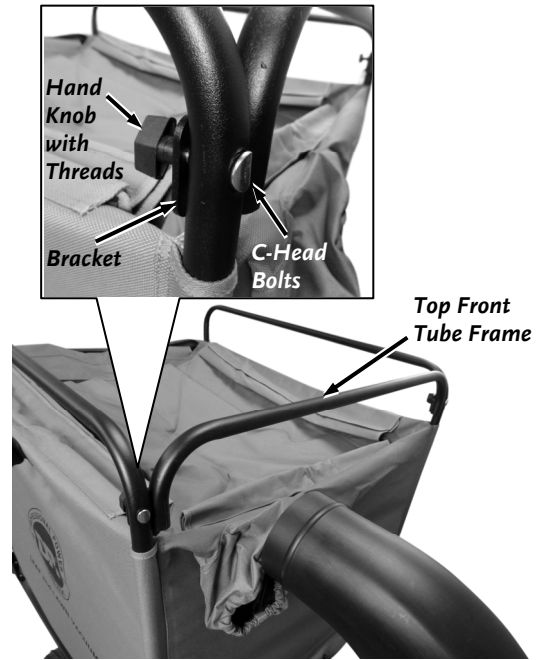

Figure 34

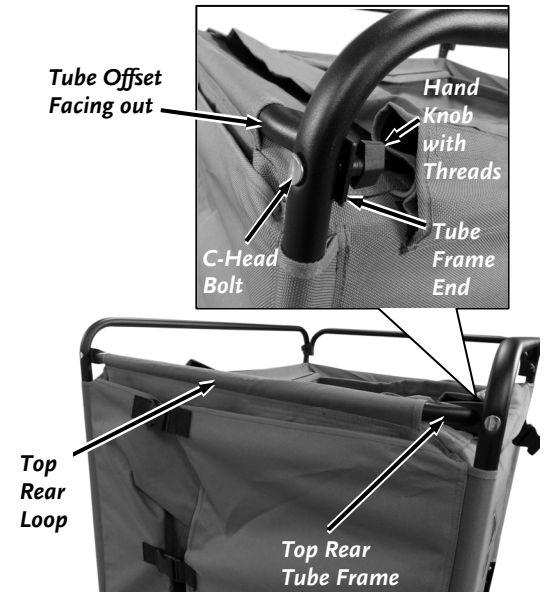

Figure 35

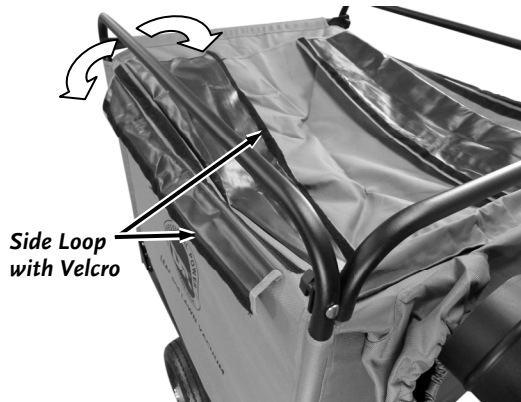

Figure 37

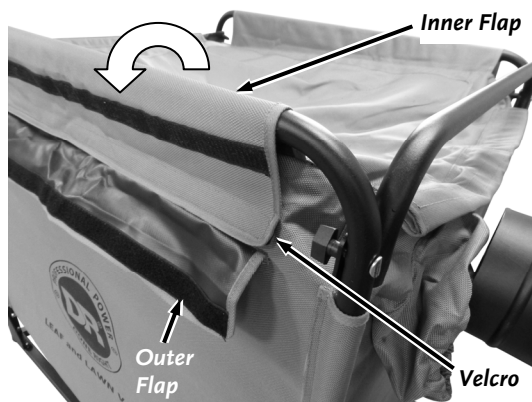

Figure 38



Figure 36

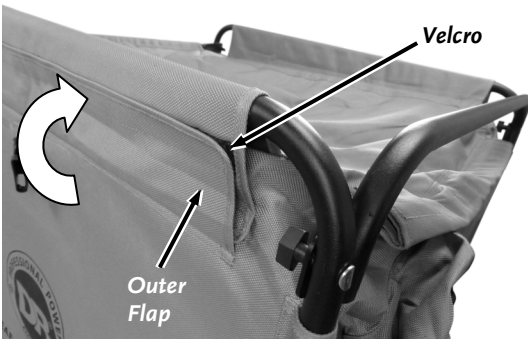

Figure 39



Figure 40



Figure 41



Figure 42

21. Lift the Outer Flap up and secure it to the Velcro on the Inner Flap. Repeat for the other side (Figure 39).
22. Open up the Front Loop by pulling at the Velcro closures to separate them (Figure 40).
23. Fold the Outer Flap over the Front Tube Frame and secure the Velcro next to the Inner Flap (Figure 41).
24. Fold the inner Flap over the outer flap and secure the Velcro at the front (Figure 42).
25. Slide the Enclosure Sleeve over the Outlet Chute (Figure 43).
26. Tighten all hardware installed in steps 9 thru 17.
27. Separate the left and right side Doors by disconnecting the three Buckles (Figure 44).
28. Separate the top and bottom Doors by disconnecting the three Buckles (Figure 45).



Figure 43

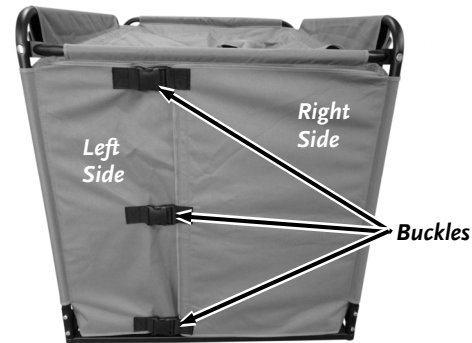

Figure 44

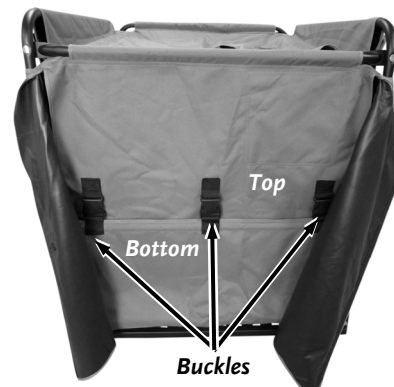

Figure 45

Note: There are seams sewn along the edges of the Door Panels to create Pockets that the Battens must be inserted into (**Figure 46**). This will enhance the performance of the latching system. One end of the Batten Pocket is open with an elastic flap concealing the opening. The other end is sewn together to retain the Batten.

29. Insert the Batten under the Elastic Flap at the corner and push it in a bit until it hits the seam (**Figure 47**).
30. Flip the Batten over 180 degrees and push it into the large pocket that runs the length of the edge and insert it in until it stops at the other end (**Figure 48**).
31. Pull the Elastic Flap out and over the end of the Batten to secure it. Repeat for the other three Battens (**Figure 49**).
32. Secure the top Door to the bottom Door with the three Buckles (**Figure 50**).
33. Secure the side Doors together with the three Buckles (**Figure 51**).



Figure 46

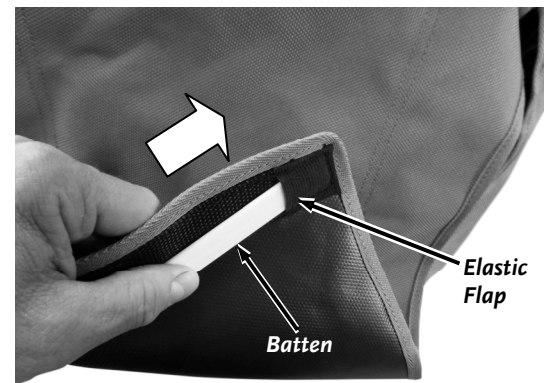

Figure 47



Figure 48



Figure 50

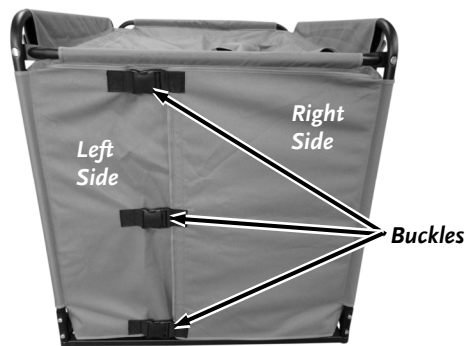

Figure 51



Figure 49

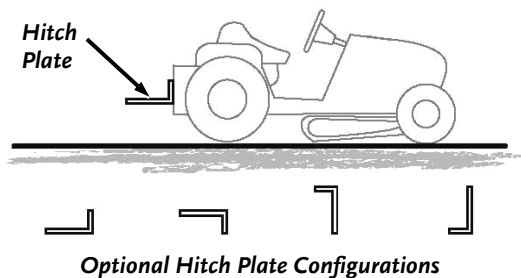

Figure 52



Figure 53

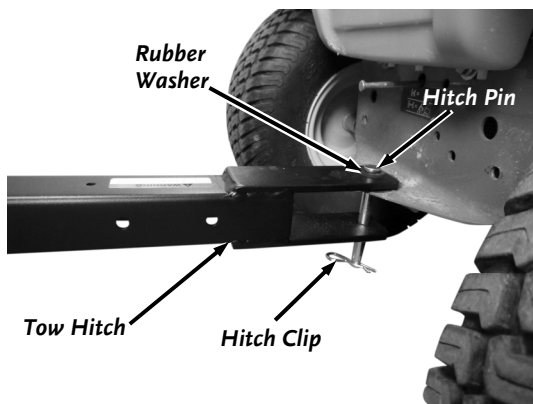

Figure 54

Setting up your Lawn Mower

Hitch Plate Kit Installation (optional)

The DR PILOT™ LEAF and LAWN VACUUM requires a Pin Hitch hole on your Lawn Mower. DR Power Equipment offers several different Hitch Plate Kits if one is not provided on your Mower (**Figure 52**). Contact us at www.DRpower.com or call one of our representatives at 1-800-DR-OWNER (376-9637) and they will be happy to assist you.

Deck Adapter Installation

The DR PILOT™ LEAF and LAWN VACUUM requires a Deck Adapter on your Lawn Mower to route material to its 8" diameter hose.

- ⇒ A DR Power Equipment Universal Deck Adapter Kit (for right hand discharge mowers) is available for you to fit to your machine if the Mower manufacturer's Deck Adapter is not available.
- ⇒ A DR Power Equipment Hose Adapter Kit is available to attach to your non DR Power Equipment Deck Adapter to our 8" diameter Hose if needed.

Contact us at www.DRpower.com or call one of our representatives at 1-800-DR-OWNER (376-9637) to order a Universal Deck Adapter Kit or Hose Adapter Kit.

1. Install the Deck Adapter onto your Lawn Mower (**Figure 53**).
2. If you do not have a DR Deck Adapter and the 8" Hose will not fit your Adapter, order a Kit from us using the contact info above. Install the Hose Adapter Kit onto the end of your Deck Adapter as described in the Kit instructions.

Connecting the DR PILOT™ LEAF and LAWN VACUUM to your Mower

NOTICE

Always raise the Jack (if equipped) prior to towing this equipment. An extended Jack can damage or deform the Jack or Frame if the Jack hits the ground or an obstacle.

1. Position the back Hitch Plate of your Mower near the Hitch of the PILOT™ LEAF and LAWN VACUUM on level ground (**Figure 54**).
2. For models not equipped with a Jack, lift the Leaf System Tow Hitch onto the Hitch Plate as shown. For models equipped with a Jack, operate the Jack to move the Frame up or down until the Tow Hitch is aligned with the Mower Hitch Plate.
3. Move the Leaf System into position on the Hitch Plate and install the Hitch Pin with Rubber Washer and Hitch Clip to secure the Tow Hitch to the Mower.
4. For models with a Jack, raise the Jack Wheel and install the Jack Safety Pin.

Connecting the Inlet Hose to the Deck Adapter

Tools Needed:

- Wire Cutters
- Knife
- Flat Head Screwdriver or 9/32" Wrench

1. Connect the Inlet Hose to the Deck Adapter by sliding the Hose Cuff over the Hose Adapter (**Figure 55**).

Tip: Position the Thumb Screw Clamp toward the Mower so it will not make contact with objects when mowing.

2. Tighten the Thumb Clamp tightly to secure the Hose to the Hose Adapter.

3. Turn the Mower all the way to the left, while watching the Hose (**Figure 56**). The Hose should not become too taut to twist or damage your Lawn Deck Adapter.

4. Adjust the Rubber Strap on the Hose to keep the Hose off the Ground. If the Strap cannot be positioned sufficiently to prevent the Hose from kinking or dragging on the ground, reduce the length of the Hose as follows.

To Shorten the Hose (if needed):

Make sure you do not shorten the Hose too much while following these procedures. Follow the steps closely to ensure the machine is not damaged.

Note: The Tractor must be turned fully to the left (**Figure 56**).

- Compress the Hose Ribs together as much as you can without stretching the Hose too much (**Figure 57**). If more than 6 Ribs can be easily compressed, the Hose should be shortened.
- Loosen the Hose Clamp that secures the Inlet Hose to the Impeller Housing with a Flat Head Screwdriver or 9/32" Wrench and pull the Hose from the Housing (**Figure 58**).
- Cut the Hose to the length required using Wire Cutters to cut the black plastic spiral and then cut the clear Hose with the razor knife (**Figure 59**).

Note: Make sure you trace the area to cut around the Hose first to ensure you will cut in the proper direction to end up on either side of the cut spiral.

- Reinstall the Hose onto the Impeller Housing and tighten the Hose Clamp. If the Tractor can be turned fully to the left, without the Hose becoming too tight (with a slight amount of sag), the Hose is the shortest length possible for your Tractor.

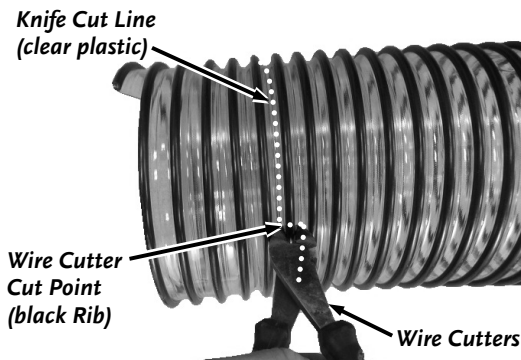

Figure 59

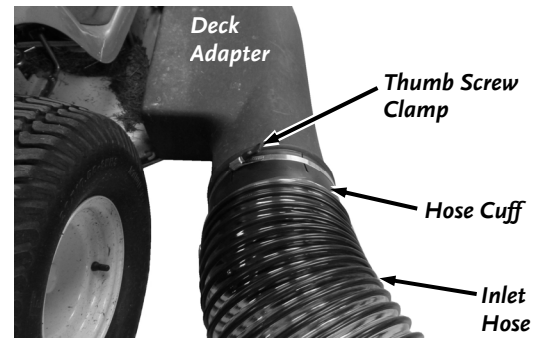

Figure 55

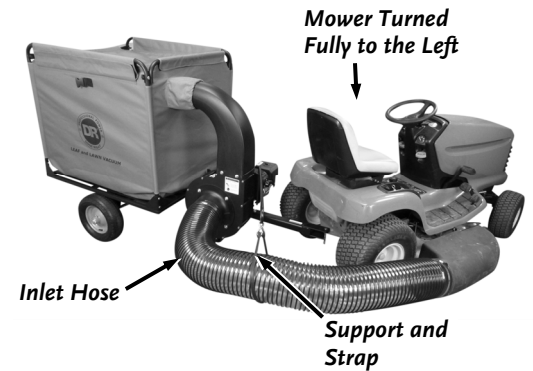

Figure 56

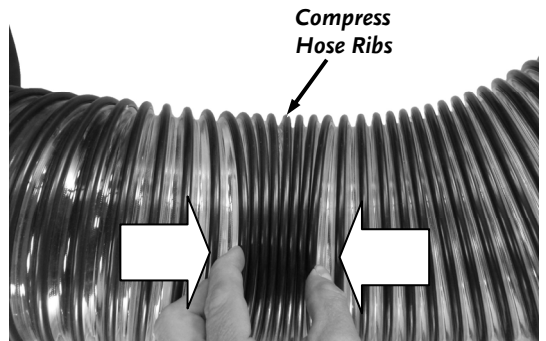

Figure 57

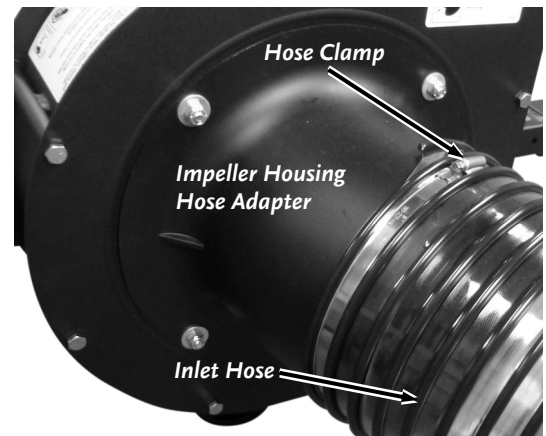

Figure 58

Adding the Engine Oil and Gasoline

Tools and Supplies Needed:

- Flexible Oil Fill Funnel (provided)
- Gas and Oil as recommended below

Tip: To avoid confusion, we recommend leaving the caps on the Fuel and Engine oil Fills and only removing one cap each time when you are ready to pour gasoline or oil into the correct Fill.

Adding Oil

Note: Use only the recommended high detergent oil. Other types of oil could cause problems operating your machine. Please refer to your Engine Owner's Manual for detailed oil information.

NOTICE

- You must add oil before starting the engine. This machine is shipped without oil. Traces of oil may be in the reservoir from factory testing, but you must add oil before starting the engine. Fill the reservoir slowly checking the dipstick frequently to avoid overfilling.
- The engine needs to be on a level surface or overfilling could occur which could damage the engine during use.
- To check the oil level, insert the dipstick all the way in, but do not screw it down.



Figure 60

1. Level the PILOT™ LEAF and LAWN VACUUM frame by adjusting the Jack height (if equipped) or by propping up the front frame.
2. Release the Dump Lever and lift the Collector to gain access to the engine oil dipstick.

Note: A flexible oil fill funnel is provided with your Leaf and Lawn Vac.

3. Remove the dipstick and add about half the quantity of the oil recommended by the Engine Manufacturer (refer to your Engine Owner's Manual for recommended quantities), and wait one minute for the oil to settle (**Figure 60**).
4. Insert the Dipstick, but do not screw it down to check the oil level. Continue adding a few ounces of oil at a time, rechecking the Dipstick until the oil reaches the fill mark. Be careful not to overfill.

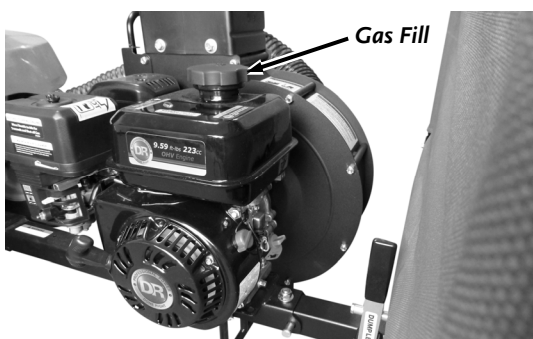

Figure 61

Adding Gasoline

1. Fill the gas tank (**Figure 61**) to within 1-1/2 inches below top of fill neck (to allow for fuel expansion) with fresh, unleaded gas. See your Engine Owner's Manual for more information.

Tire Pressure Check

Tools Needed:

- Tire Pressure Gauge
- Air Compressor

! WARNING

Do not over inflate the tires. Inflate to the manufacturers recommended pressure found on the tires.

1. Remove the Valve Stem Protective Cap (**Figure 62**) and check the tire pressure with a Tire Pressure Gauge.
2. Check what the manufacturers recommended pressure is that is stamped on the side of the Tire.
3. If the pressure is too low, add air through the Valve Stem with an air hose.
4. Replace the Valve Stem Protective Cap when finished.



**Valve Stem
with Cap**

Figure 62

Chapter 3: Operating The DR PILOT™ LEAF AND LAWN VACUUM

It may be helpful to better familiarize yourself with the features of your DR PILOT™ LEAF and LAWN VACUUM by reviewing **Figure 1** in Chapter 2 before beginning the steps outlined in this chapter.

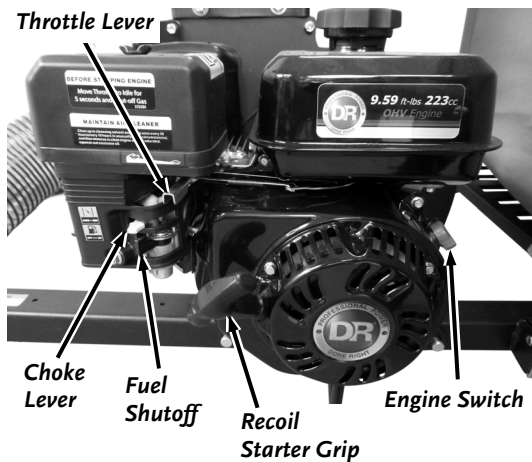

Figure 63

Before Starting the Engine

NOTICE

For best performance we recommended that you operate your Leaf and Lawn Vacuum in temperatures 40°F and above.

⚠ WARNING

- Inspect the area where you will be working. The site must be free of potentially hazardous obstacles such as stones, metal, or glass. Also, make sure there won't be people or animals in the area around the DR Leaf and Lawn Vacuum.
 - Always refer to the Engine “Operator’s Manual” that came with your machine for more detailed Engine operation procedures.
1. Connect the DR PILOT™ LEAF and LAWN VACUUM to your Lawn Tractor (see previous chapter), remove the Safety Hitch Pin from the Jack (if equipped), raise the Jack up and out of the way and replace the Safety Hitch Pin.
 2. Check the Engine oil level every time you use the machine (refer to your Engine Operator’s Manual).
 3. Check the Fuel level and make sure the Fuel Shut-Off Valve is in the OPEN position (refer to your Engine Operator’s Manual).

Starting and Stopping the Engine

1. When starting a cold Engine; push the Choke Control lever to the left (CHOKE) and the Throttle Control lever to the far left (rabbit position) (**Figure 63**). If re-starting a warm Engine, leave the Choke in the (RUN) position.
2. Grasp the Recoil Starter Handle and slowly pull until you feel resistance, then pull the cord with a smooth accelerating motion to start the engine. One or two pulls usually starts the DR PILOT™ LEAF and LAWN VACUUM.
3. After the Engine starts, slowly push the Choke Control lever back to the (RUN) position. Wait until the Engine runs smoothly before each Choke adjustment. When vacuuming you must operate the Engine with the Throttle in the Fast (Rabbit) position.
4. **To stop the Engine**, move the Throttle to the Slow (Turtle) position allowing the Engine to idle, shut off the gas, and then turn the Engine Switch to “OFF” position.

Operating Safety

! WARNING

- Never put your hands inside the vacuum hose while the engine is running. Always stop the engine and disconnect the spark plug wire before clearing the vacuum hose.
- Do not refuel the engine while it is hot or running.

NOTICE

Use common sense when using the machine. Learn to recognize the change in sounds when overloaded. Stop the engine immediately if the machine becomes jammed to prevent damage to the machine.

Towing the DR PILOT™ LEAF and LAWN VACUUM

1. Make sure you firmly attach the DR PILOT™ LEAF and LAWN VACUUM Hitch to your Lawn Tractor using the Hitch Pin and Hitch Clip (**Figure 64**).
2. If equipped with a Jack, make sure the wheel is in the fully raised position and the Jack Safety Pin is installed to lock it in place.
3. Make sure the Collector Base is on the Frame with the Dump Lever locked over the Latch Pin (**Figure 65**), the Enclosure Sleeve is over the Outlet Chute (**Figure 66**), and the Inlet Hose Cuff is securely attached to the Deck Adapter on your Tractor (**Figure 67**).

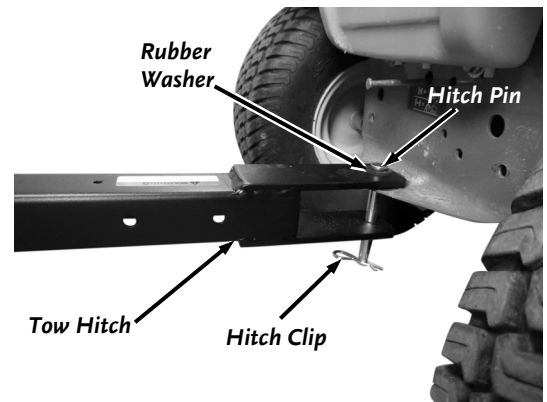

Figure 64

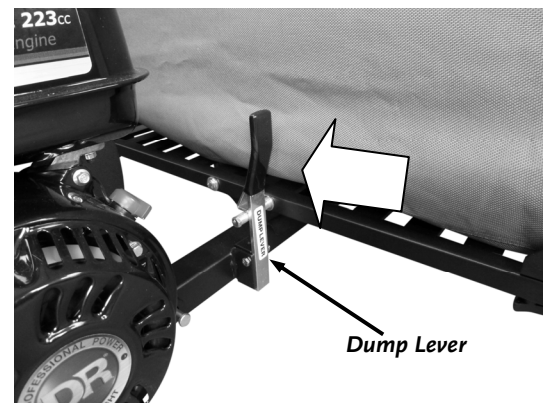

Figure 65

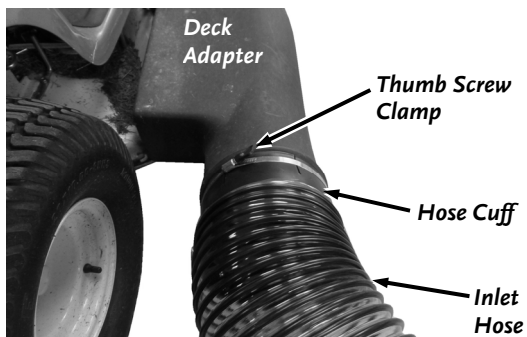

Figure 67

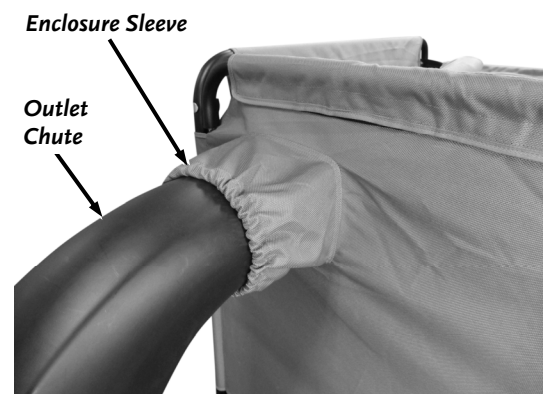

Figure 66

Towing Safety

! WARNING

- Watch out for low branches, overhangs, and guy wires that may catch on top of the collector.
- Never allow anyone to ride in or on the DR Leaf and Lawn Vacuum.
- Obey local, state, and federal regulations when you tow the DR leaf and lawn vacuum across public roads and highways.
- Use caution when backing up your lawn tractor or trying to make tight turns going forward with the DR Leaf and Lawn Vacuum attached. Trying to turn too sharply can cause damage to the hitch and/or the lawn tractor if you hit an obstacle. Go slowly in areas where tight turns are necessary. Straighten out the system before attempting to back up.

Slopes and Uneven Terrain

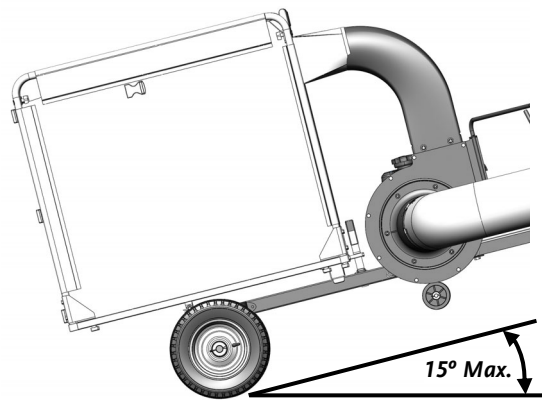

Figure 68

! WARNING

- Do not use the DR Leaf and Lawn Vacuum on slopes greater than 15 degrees (**Figure 68**). Doing so could result in serious injury to yourself or damage to your machine.
- When operating the DR Leaf and Lawn Vacuum over uneven terrain and slopes, use extreme caution to not tip over the machine. Move slowly, especially with a full load, if the ground has ruts, bumps, and other depressions.
- On a slope, a heavy load will tend to shift. When using your DR Leaf and Lawn Vacuum, keep in mind that loads tend to shift to the downhill side of the collector enclosure. The higher and heavier the load, the greater the chance you may tip over the machine.
- Travel up and down slopes and avoid going across slopes. This is the same recommendation for mowing with your lawn tractor alone.

PILOT™ LEAF and LAWN VACUUM

Tips

Note: Make sure the Engine is at full throttle when mowing and vacuuming leaves.

! WARNING

Always pick up stones, metal objects, glass, and sticks before vacuuming.

Be careful in corners. Practice in first gear to understand the effects of the machine on your ability to turn sharply. Drive your DR PILOT™ LEAF and LAWN VACUUM into the corner of your property and back out straight to mow as close to the corner as possible. Do not go through ditches.

- The Lawn Deck of your mower may tend to scatter some leaves in front and to the right of the Lawn Deck. Keeping the discharge side toward the remaining leaves will simplify cleanup by avoiding blowing leaves back onto the areas that you already finished. When you need to vacuum with the discharge side toward the completed area of the lawn, overlap the discharge side of the Lawn Deck at least a foot over the already completed section of the lawn.
- To prevent clogging the Deck Adapter, mow grass that is dry and not more 2" at a time. To keep your grass healthy, we recommend cutting less than 1/3 the grass height.
- Run your Lawn Deck with your Tractor at full throttle all the time to maximize the lift from your Lawn Deck and assist your DR PILOT™ LEAF and LAWN VACUUM system.
- Avoid dragging the Hose over curbs, stonewalls, or piles of cut branches. The Hose is tough, but can puncture on sharp objects. This could also crack the Mower Deck Adapter.
- Cut wet grass can be very heavy. Fill the Collector only 3/4 full if the material is very wet. That will make the Leaf System easier to pull and to dump.

Dumping

! WARNING

- Always shut off the tractor engine and the vacuum engine and use caution when dumping the collector load.
- Never back up with the Collector in the dump position.

1. Shut down the Mower and Vacuum Engines and set the Mower Parking Brake when you are at the Dump area.
2. Separate the left and right side Doors by disconnecting the three Buckles (**Figure 69**).
3. Attach the top Buckles of the side Doors to the Buckles at both sides of the Enclosure (**Figure 70**).
4. Separate the top and bottom Doors by disconnecting the three Buckles (**Figure 71**).
5. Pull the Dump Lever to tip the Collector back (**Figure 72**). Push against the Top Tube Frame to start the tipping (**Figure 73**). Help slide the Enclosure Sleeve off the Outlet Chute if necessary.
6. Drive the Mower forward with the Collector fully open to move the Leaf System away from the pile of debris and allow all debris to slide from the Bed.
7. Shake the Collector if necessary to loosen any debris that remains in the bottom.

! CAUTION

Never drive in reverse with the Collector in the dump position.

8. Pull down at the front of the Collector until the Latch is secured by the Dump Lever (**Figure 72**).
9. Close the Top and Bottom Doors and secure the three Buckles.
10. Undo the Buckles at the sides, close the Left and Right Doors and secure with the three Buckles.

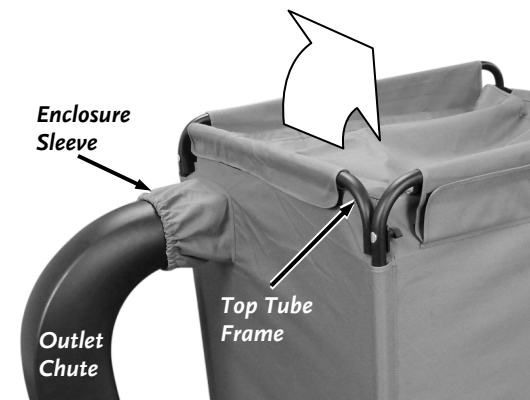

Figure 73

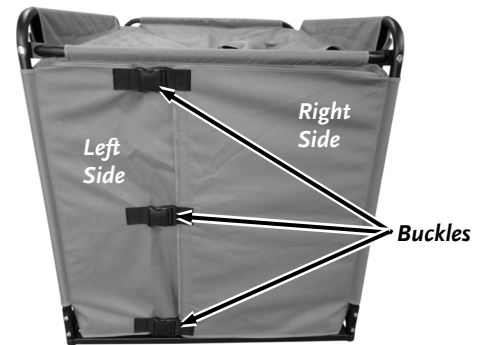

Figure 69



Figure 70



Figure 71

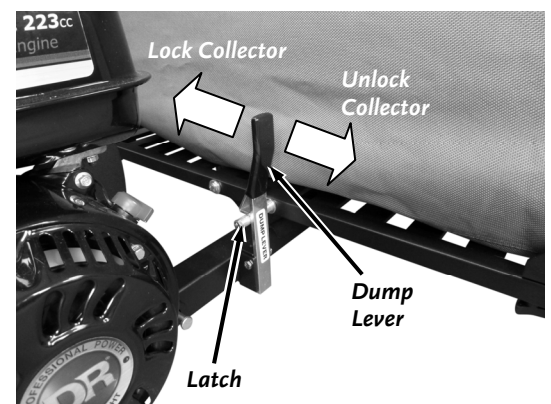

Figure 72

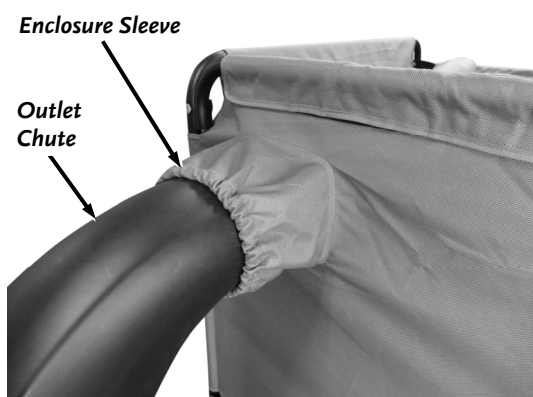

Figure 74

11. Pull the Enclosure Sleeve around the Outlet Chute (*Figure 74*).

! CAUTION

Empty the Collector after each use. Do not store the Leaf System with debris in the Collector.

Converting to Flatbed Trailer Mode

! WARNING

Before performing this procedure, you must first shut off the mower and leaf and lawn vacuum engines, wait five minutes for all parts to stop and cool, and disconnect the spark plug wire of the leaf and lawn vacuum.

Tools Needed:

- Flat Head Screwdriver or 9/32" Wrench
- Two 3/4" Wrenches

1. Remove the Rubber Bungee from the Hose Support (**Figure 75**).
2. Remove the Hose Support from the Bracket.
3. Disconnect the Hose from the Impeller Housing using a Flat Head Screwdriver or 9/32" Wrench (**Figure 76**).
4. Turn the Thumb Screw Clamp to disconnect the Hose from the Deck Adapter (**Figure 77**).
5. Pull the Enclosure Sleeve from the Outlet Chute (**Figure 78**).
6. Remove the six Knob Bolts from under the Collector Base corners (**Figure 79**).
7. Loosen the Knobs at the top corners (you do not need to remove them).
8. With help from another person, lift the Enclosure from the Flatbed and set it aside.

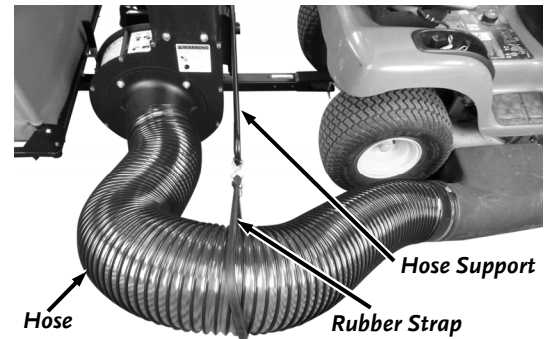

Figure 75

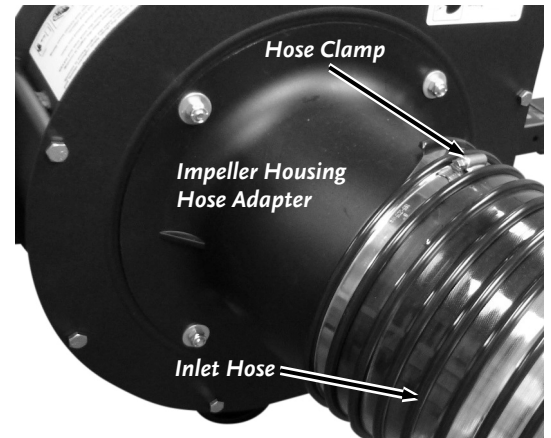

Figure 76

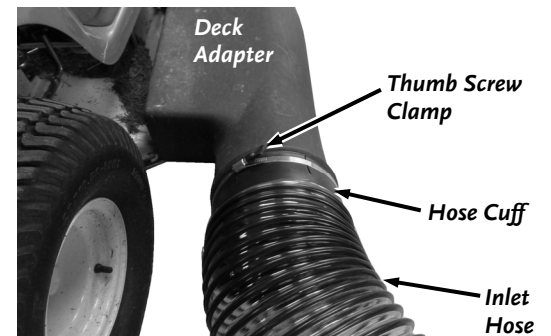

Figure 77



Figure 79

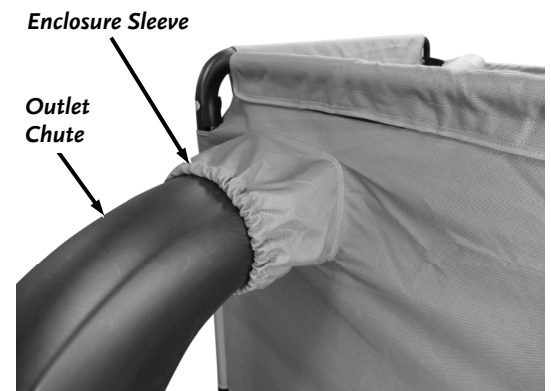

Figure 78

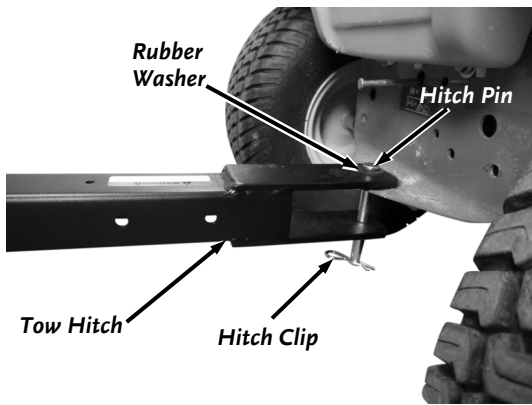

Figure 80

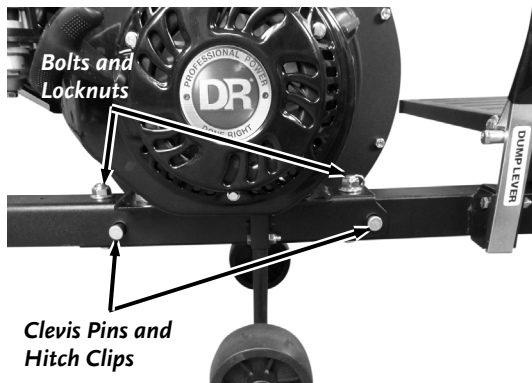

Figure 81

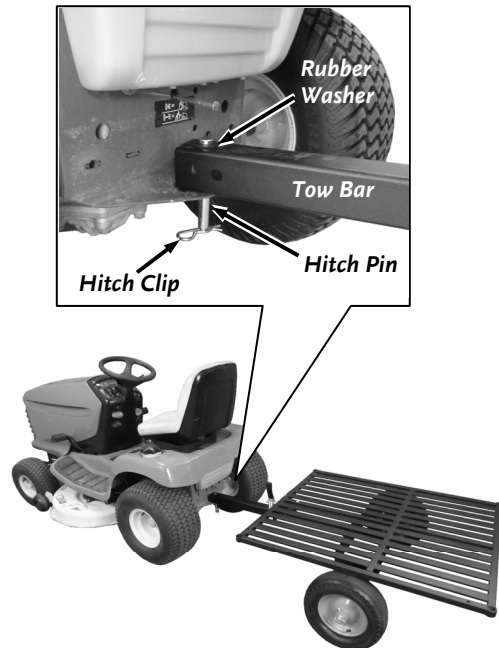

Figure 82

9. Disconnect the Tow Hitch from the Tow Vehicle and keep the Hitch Pin, Rubber Washer and Hitch Clip for securing the Flatbed Trailer in the next section (Figure 80).
10. Remove the two sets of Bolts and Locknuts from the Frame using two 3/4" Wrenches (Figure 81).
11. Block the Wheels and have a helper support the Engine to take pressure off the Pins when you perform the next step.
12. Remove the front (closest to the Hitch) Hitch Clip and Clevis Pin from the Power Unit Frame.
13. Remove the rear Hitch Clip and Clevis Pin from the Power Unit Frame.
14. Pull the Power Unit away from the Flatbed Trailer and store Power Unit, Hose, Hose Support and Hardware.

Using the Flatbed Trailer

! WARNING

- Never allow anyone to ride on the Flatbed.
- Do not tow on slopes greater than 15 degrees.
- Travel up and down slopes and avoid going across slopes. This is the same recommendation for using your lawn tractor alone.
- Never backup with the Flatbed in the dump position.

1. Hitch the Tow Bar to your Mower using the Hitch Pin with Rubber Washer and secure using the Hitch Clip (Figure 82).

Tips:

- Be careful in corners. Practice in first gear to understand the effects of the machine on your ability to turn sharply. Do not tow through ditches..
- Distribute material as evenly as possible on the Flatbed.
- Never tow more than 400 lbs of material at one time.
- Take extra care whenever you are towing long material that hangs over the Flatbed.
- Use bungee cords or straps to hold awkward material down when necessary.
- Don't throw small heavy items (like a bulky rock) onto the Flatbed. Place them on and then strap them down.

Collapsing the Collector for Compact Storage

The Collector can be stored fully assembled but can also be collapsed for more compact storage.

1. Unlatch the Buckles that secure the left and right side Doors (**Figure 83**).
2. Unlatch the Buckles that secure the top and bottom Doors (**Figure 84**).

Note: Only the Battens in the top and bottom Doors need to be removed to fold the Enclosure for storage.

3. On the inner right side corner of the top Door, push the Batten into the Elastic Flap (**Figure 85**), Fold the Elastic Flap down over the end of the Batten to expose it (**Figure 86**). Remove the Batten.
4. Remove the Batten in the bottom Door.
5. Reconnect the Buckles to secure all four Doors.
6. Unhook the Velcro Flaps that secure the Enclosure to the Top Front Tube (**Figure 87**).
7. Remove the Hand Knobs and the C-Head Bolts that secure the Top Front Tube Frame and remove the Tube Frame.
8. Remove the Hand Knobs and the C-Head Bolts that secure the Top Rear Tube Frame and remove the Tube Frame from the Enclosure Loop.
9. Tuck in the Enclosure ends as you bring the two Collector Tubes together for storage (**Figure 88**).

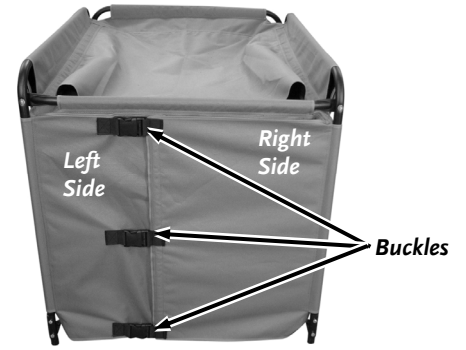

Figure 83



Figure 84

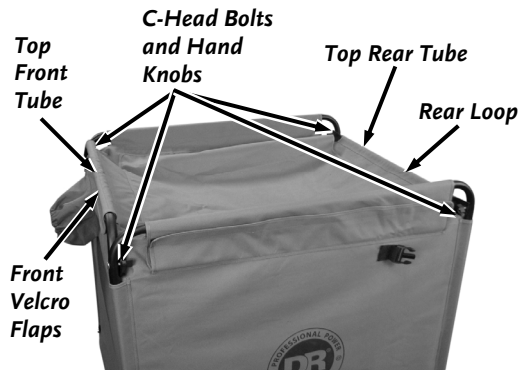

Figure 87

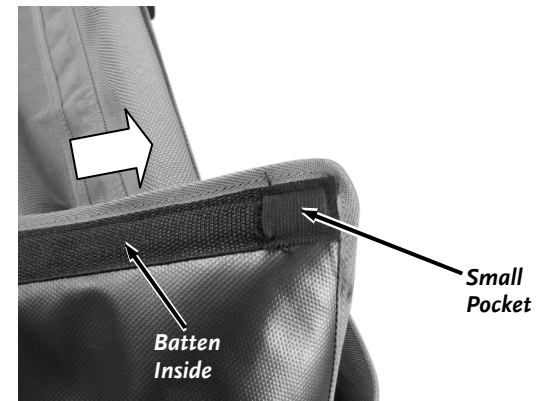

Figure 85



Figure 88

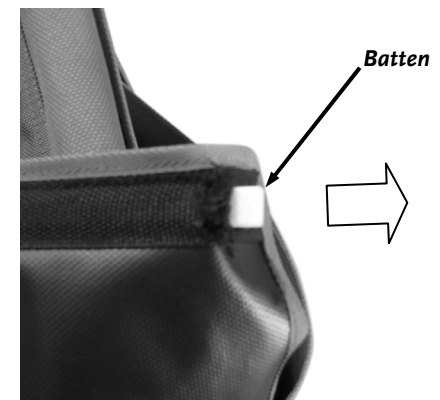

Figure 86

Chapter 4: Maintaining the DR PILOT™ LEAF and LAWN VACUUM

Regular maintenance is the way to ensure the best performance and long life of your machine. Please refer to this manual and the engine manufacturer's owner's manual for maintenance procedures. Service intervals listed in the checklist below supersede those listed in the engine manufacturer's owner's manual.

! WARNING

Before performing any maintenance, repairs, or inspection, you must first shut off the mower and leaf and lawn vacuum engines, wait five minutes for all parts to stop and cool, and disconnect the spark plug wire of the leaf and lawn vacuum.

Regular Maintenance Checklist

PROCEDURE	BEFORE EACH USE	AFTER EACH USE	EVERY 25 HOURS	EVERY 100 HOURS
Check Engine Oil Level	▲			
Check General Equipment Condition, e.g. tight nuts, bolts, welds, etc.	▲			
Check Tire Pressure	▲			
Check Hose for wear, holes, or abraded areas	▲			
Clean Engine Exterior & Cooling Fins	▲			
Clean Engine Air Filters, replace as needed*	▲			
Empty the Collector		▲		
Change Engine Oil	1 st time 5 hours		▲	
Check Exterior of Impeller Housing for Wear			▲	
Lubricate Wheel Bearings				▲
Replace Spark Plug				▲
Replace Engine Air Filters				▲

*Replace the filter if excess oil is found on the foam element or any oil is found in the paper element.

Lubrication

Your DR PILOT™ LEAF and LAWN VACUUM was lubricated at the Factory. The operator needs to provide Engine lubrication and lubricate the Wheels periodically.

! WARNING

Before performing any maintenance, repairs, or inspection, you must first shut off the mower and leaf and lawn vacuum engines, wait five minutes for all parts to stop and cool, and disconnect the spark plug wire of the leaf and lawn vacuum.



Figure 89

Tools and Supplies Needed:

- Grease gun with Multipurpose Automotive Grease
- Clean Rags

LUBRICATE WHEEL BEARINGS:

1. Clean the Grease Fitting with a clean Rag (**Figure 89**).
2. Lubricate each Wheel with Multipurpose Automotive Grease using a grease gun on the Grease Fitting.

REMOVING AND REPLACING THE ENGINE OIL

Refer to page 22 as well as the Engine Operator Manual for Engine Procedures for removing and replacing the oil.

Note: Be sure to use environmentally safe disposal procedures in the disposing of the used oil.

Replacing the Wheels

WARNING

Before performing any maintenance, repairs, or inspection, you must first shut off the mower and leaf and lawn vacuum engines, wait five minutes for all parts to stop and cool, and disconnect the spark plug wire of the leaf and lawn vacuum.

Tools Needed:

- Locking Pliers or Needle Nose Pliers.
- Jack and Stand

1. Jack up the Frame and support it with Blocks or a Jack Stand so the Wheel is off the ground.
2. Remove the Cotter Pin with Locking Pliers or Needle Nose Pliers (**Figure 90**).
3. Remove the Large Washer and Wheel.
4. Install the new Wheel.
5. Install the Large Washer and secure with the Cotter Pin (bend the ends of the Cotter Pin to lock it onto the Axle).



Figure 90

Impeller Maintenance

An Impeller Tool is provided in case you ever need to remove the Impeller for service. Simply remove the Bolt and Washer holding the Impeller onto the Engine Shaft and thread the Impeller Tool into the Impeller until it releases from the Engine (**Figure 91**).

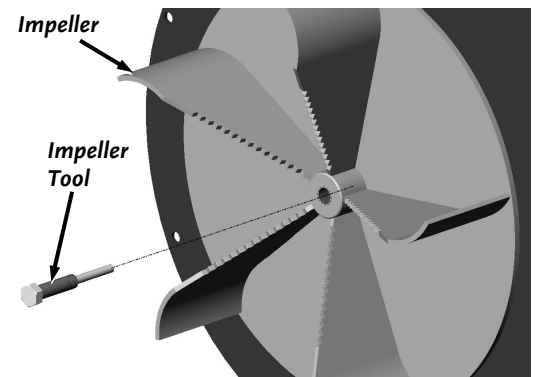

Figure 91

Chapter 5: Troubleshooting

Most problems are easy to fix. Consult the Troubleshooting Table below for common problems and their solutions. If you continue to experience problems, contact us at www.DRpower.com or call toll-free 1-800-DR-OWNER (376-9637) for support.

WARNING

Before performing any maintenance, repairs, or inspection, you must first shut off the Mower and Leaf and Lawn Vacuum engines, wait five minutes for all parts to stop and cool, and disconnect the Spark Plug Wire of the Leaf and Lawn Vacuum.

Troubleshooting Table

SYMPTOM	POSSIBLE CAUSE
<i>Engine recoil will not pull out or is difficult to pull.</i>	<ul style="list-style-type: none"> ⇒ Check the Engine oil level, the Engine may be seized. See your engine owner's manual. ⇒ There may be an oil compression lock in the cylinder. Take out the Spark Plug; hold a rag over the Spark Plug hole and pull the Recoil Cord several times to blow out any oil in the cylinder. Wipe off the Spark Plug and reinstall it. ⇒ The Recoil may be broken or jammed. Visit us at www.DRpower.com or call 1-800-DR-OWNER (376-9637) for assistance.
<i>The Engine won't start (Please refer to the Engine Owner's Manual for engine-specific procedures.)</i>	<ul style="list-style-type: none"> ⇒ Check that the Spark Plug Wire is attached. ⇒ Check the oil and gas level. See your engine owner's manual. ⇒ You should be using fresh, clean gas. If the gas is old, change it. Use a fuel stabilizer if you keep gas longer than one month. ⇒ Check the Throttle adjustment and travel. See your engine owner's manual. ⇒ The Spark Plug should be clean. If the Spark Plug is dirty or cracked, change it. If it's oily, leave it out, hold a rag over the Plug hole and pull the Recoil Cord several times to blow out any oil in the cylinder, then wipe off the Plug and reinstall it. ⇒ If the Engine still won't start, visit us at www.DRpower.com or call 1-800-DR-OWNER (376-9637) for assistance.
<i>Engine smokes.</i>	<ul style="list-style-type: none"> ⇒ Check the oil level and adjust as needed. ⇒ You may be operating the machine on too great an incline. See "Slopes and Uneven Terrain" on page 26. ⇒ Check the Air Filter and clean or replace if needed. ⇒ You may be using the wrong oil—too light for the temperature. Refer to your Engine Owner's Manual for detailed information. ⇒ Clean the Engine cooling fins and the carburetor housing if they are dirty. ⇒ If the Engine still smokes, visit us at www.DRpower.com or call 1-800-DR-OWNER (376-9637) for assistance.

Troubleshooting Table (Continued)

WARNING

Before performing any maintenance, repairs, or inspection, you must first shut off the mower and leaf and lawn vacuum engines, wait five minutes for all parts to stop and cool, and disconnect the spark plug wire of the leaf and lawn vacuum.

SYMPTOM	POSSIBLE CAUSE
<p><i>The Engine lacks power or is not running smoothly.</i></p> <p><i>(Please refer to the Engine Owner's Manual for engine-specific procedures.)</i></p>	<ul style="list-style-type: none"> ⇒ Check the Throttle travel. See your engine owner's manual. ⇒ The Choke should be pushed all the way to the right (RUN). See your engine owner's manual. ⇒ Check to see if the Air Filter is clean. If it's dirty, change it following the procedure in the Engine Owner's Manual. ⇒ The Spark Plug should be clean. If the Spark Plug is dirty or cracked, change it. If it's oily, leave it out, hold a rag over the Plug hole and pull the Recoil Cord several times to blow out any oil in the cylinder, then wipe off the Plug and reinsert it. ⇒ You should be using fresh, clean gas. If the gas is old, change it. Use a fuel stabilizer if you keep gas longer than one month. ⇒ Check and make sure the Engine has the right amount of clean oil. If it's dirty, change it following the procedure in your engine owner's manual. ⇒ If your Engine still lacks power, visit us at www.DRpower.com or call 1-800-DR-OWNER (376-9637) for assistance.
<p><i>Wheels tracking left or right while being towed.</i></p>	<ul style="list-style-type: none"> ⇒ Check the tire pressure. Refer to the Tire manufacturers recommended pressure on the side of the Tire and adjust pressure as needed.
<p><i>Lawn Deck is not vacuuming well.</i></p>	<ul style="list-style-type: none"> ⇒ Be sure the PILOT™ LEAF and LAWN VACUUM Engine is running at full throttle. ⇒ Be sure the Lawn Deck Blades are engaged and running at full throttle. ⇒ Be sure the Deck is set at the proper mowing height. ⇒ Use 1st or 2nd gear on your Lawn Tractor for best results. ⇒ Turn off the Lawn Tractor Engine and Vacuum Engine and check the Deck Adapter for clogs. ⇒ Look for clogs along the Hose. Shake the Hose to loosen and free any clog. ⇒ Turn off the Lawn Tractor Engine and PILOT™ LEAF and LAWN VACUUM Engine and disconnect the PILOT™ LEAF and LAWN VACUUM Engine Spark Plug Wire. Check for clogs in the Outlet Chute and Inlet Hose. ⇒ If your Lawn Deck still is not vacuuming properly, visit us at www.DRpower.com or call 1-800-DR-OWNER (376-9637) for assistance.
<p><i>Leaves or grass come out of the back of the Enclosure.</i></p>	<ul style="list-style-type: none"> ⇒ Check that all rear Doors are secured with the Buckles and that the Top and Bottom Doors are buckled first, and the Side Doors are buckled last.
<p><i>Leaves or grass come out where the Outlet Chute and Enclosure meet.</i></p>	<ul style="list-style-type: none"> ⇒ Be sure the Enclosure Sleeve is fully installed around the Outlet Chute.
<p><i>The Collector does not fully latch</i></p>	<ul style="list-style-type: none"> ⇒ Pull the Collector down rapidly against the latch. If the latch does not return fully, move it closed manually, loosen the bolt going through the latch pin and retighten the bolt.

Schematic – FRAME AND BED ASSEMBLY

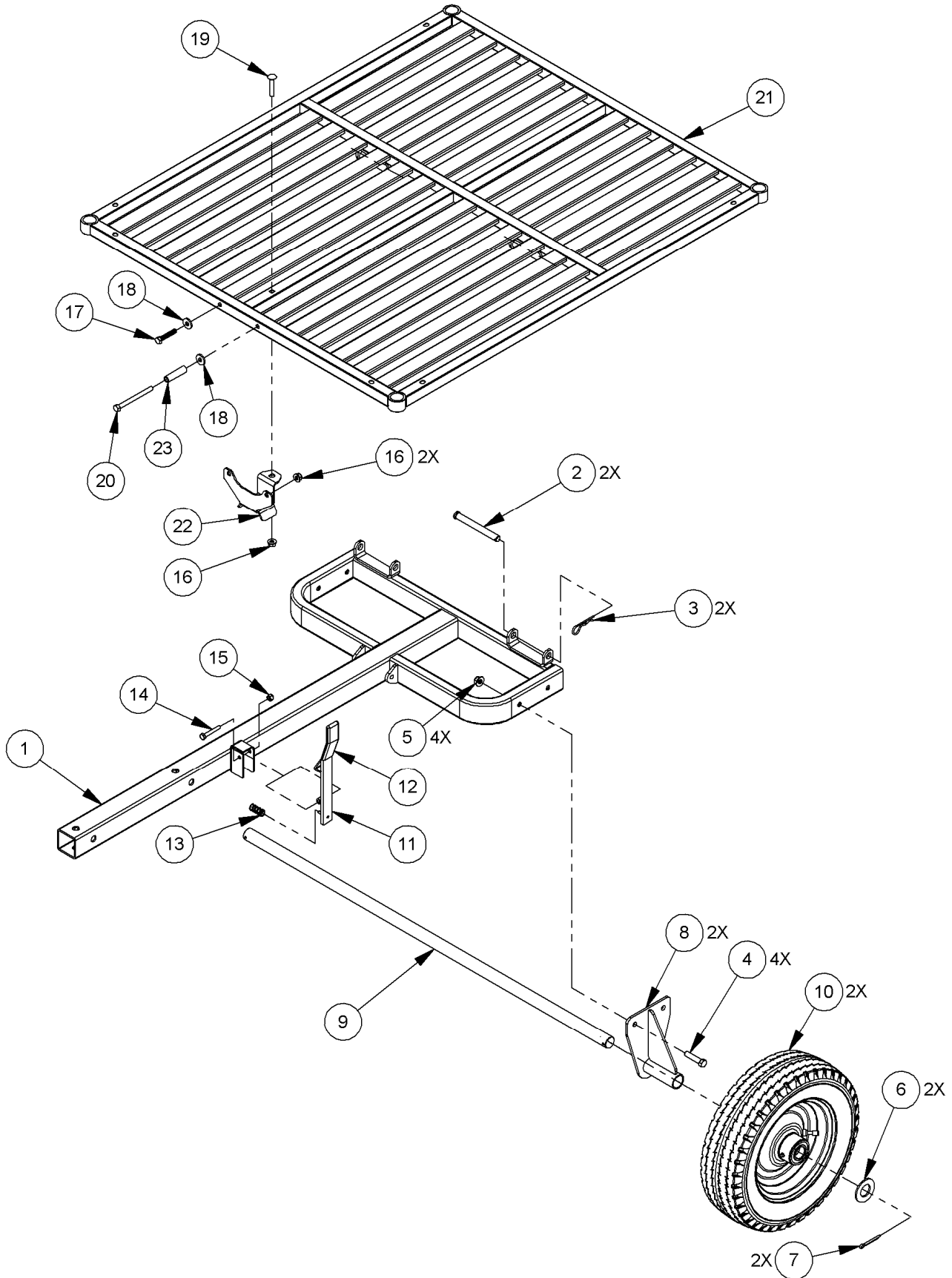

Parts List – POWER UNIT ASSEMBLY

NOTE: Part numbers listed are available through DR Power Equipment.

<u>Ref#</u>	<u>Part#</u>	<u>Description</u>	<u>Ref#</u>	<u>Part#</u>	<u>Description</u>
1	187371	Pin, Clevis, 1/2" OD X 4.5" Lg	24	235001	Pin, Cotter, 7/64" X 1", ZP
2	160031	Pin, Hair, 1/2" To 9/16", .12" Wire	25	394311	Frame, Front
3	110731	Nut, Nylon Lock, 1/4-20, ZP	26	388621	Axle, Power Unit
4	134431	Bolt, HCS, 5/16-18 X 1-1/2", GR5, ZP	27	342771	Wheel, 4"
5	333321	Nut, Nylon Lock, Flanged, 5/16-18	28	350231	Bolt, Hex, Flange, 5/16-18 X .75"
6	350311	Bolt, HCS, 5/16-24 X 3.0", GR8, YZP	29	112431	Washer, Lock, Split, 5/16"
7	350321	Washer, Lock, Split, 5/16", GR8, ZP	30	112411	Washer, Flat, 5/16" USS, ZP
8	354331	Engine, w/Labels, DR 9.59 TQ, M/S, 50ST	31	388581	Chute, Impeller Outlet
9	342401	Spacer, Impeller	32	123211	Bolt, HCS, 5/16-18 X 3/4", GR5, ZP
10	A0000072109	Bolt, HCS, 5/16-24 X 2.5", GR8, YZP	33	388591	Adapter, Hose, Impeller Housing
11	350361	Washer, Flat, .344" X 1.25" X .25", ZP	34	342441	Rod, Support, Hose
12	187551	Nut, Nylon Lock, 5/16-18, LP	35	388691	Sideplate, Housing, Hose, w/Labels
13	386401	Bolt, HCS, 5/16-18 X 6", GR5, ZP	<u>Not Shown</u>		
14	A0000094783	Impeller		370361	Funnel, Oil Flexible
15	388551	Sideplate, Housing, Engine		388491	Label, Warning, Operating
16	388701	Scroll, Housing, w/Labels		388501	Label, Warning, Icons
17	342431	Bracket, Rod, Hose		127811	Label, Warning, Add Oil
18	265561	Bolt, HCS, 1/2-13 X 2.75", GR5, ZP		137581	Label, Check Oil, 2.75x .63
19	333351	Nut, Nylon Lock, Flanged, 1/2-13		188871	Label, Hot Surface R/C
20	211541	Pin, Clevis, 1/2" OD X 3.5" Lg		342781	Label, Warning, Chutes & Hose
21	189671	Washer, Neoprene, .49" ID X 1.06" OD		372291	Label, Do Not Over Fill Oil
22	114681	Bolt, HHCS, 1/4-20 X 2.0", GR2, ZP		372301	Label, Idle Before Stop
23	234991	Washer, SAE Flat, 1/2", ZP			

Schematic – POWER UNIT ASSEMBLY

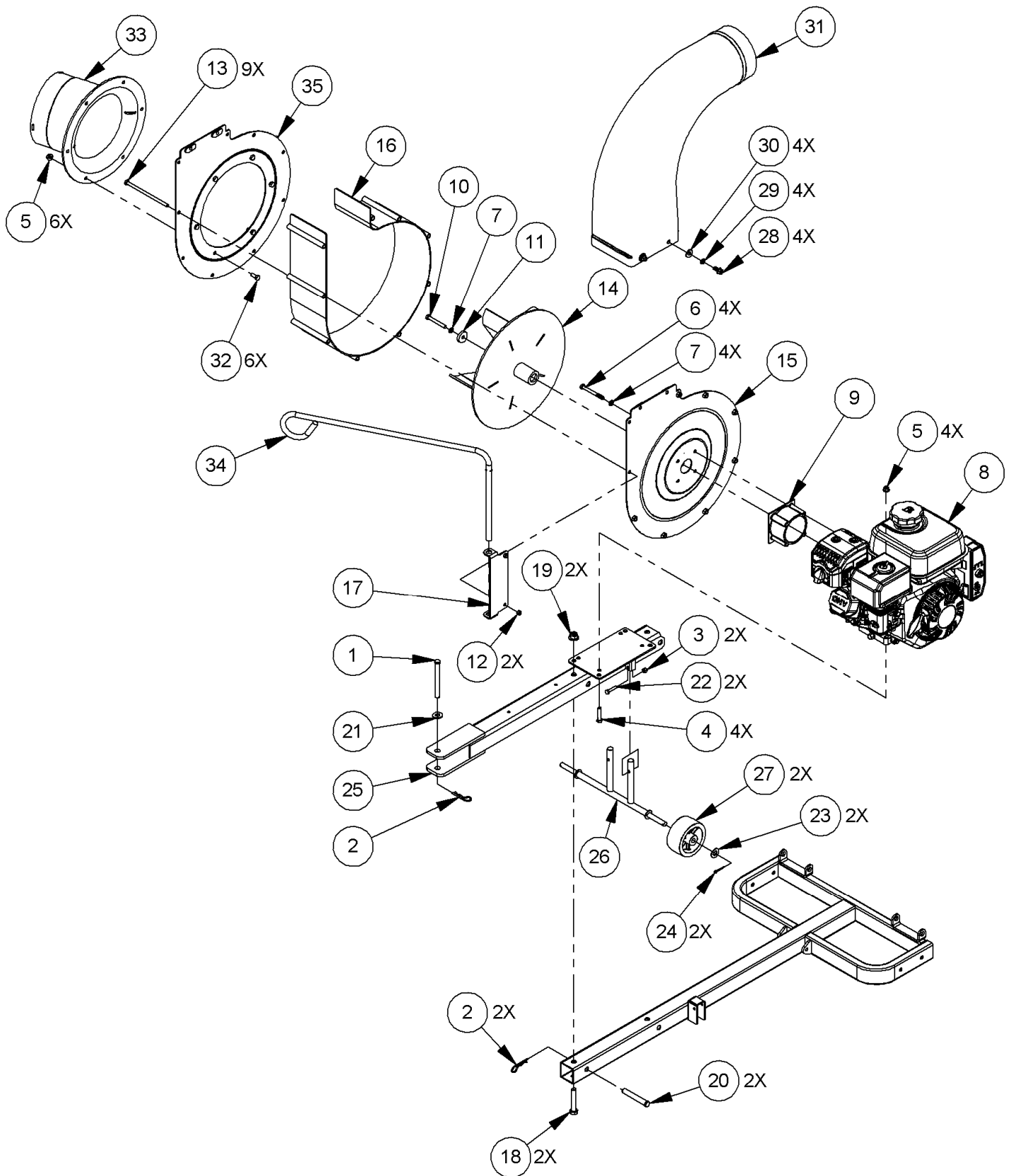

Parts List – COLLECTOR ASSEMBLY

NOTE: Part numbers listed are available through DR Power Equipment.

<u>Ref#</u>	<u>Part#</u>	<u>Description</u>	<u>Ref#</u>	<u>Part#</u>	<u>Description</u>
1	134431	Bolt, HCS, 5/16-18 X 1-1/2", GR5, ZP	8	388441	Tube, Collector
2	110761	Nut, Nylon Lock, 5/16-18, ZP	9	388451	Bracket, Tube, Front LH
3	350271	Bolt, C-Head, 5/16-18 X 1.75", ZP	10	388471	Bracket, Tube, Rear LH
4	350301	Knob, 5/16-18 W/Lock, 1.16" X .93"	11	388461	Bracket, Tube, Front RH
5	388511	Tube, Frame, Top Front	12	388481	Bracket, Tube, Rear RH
6	388521	Tube, Frame, Top Rear	13	388541	Enclosure, Fabric
7	388611	Knob, 3 Prong, 5/16-18 Stud			

Schematic – COLLECTOR ASSEMBLY

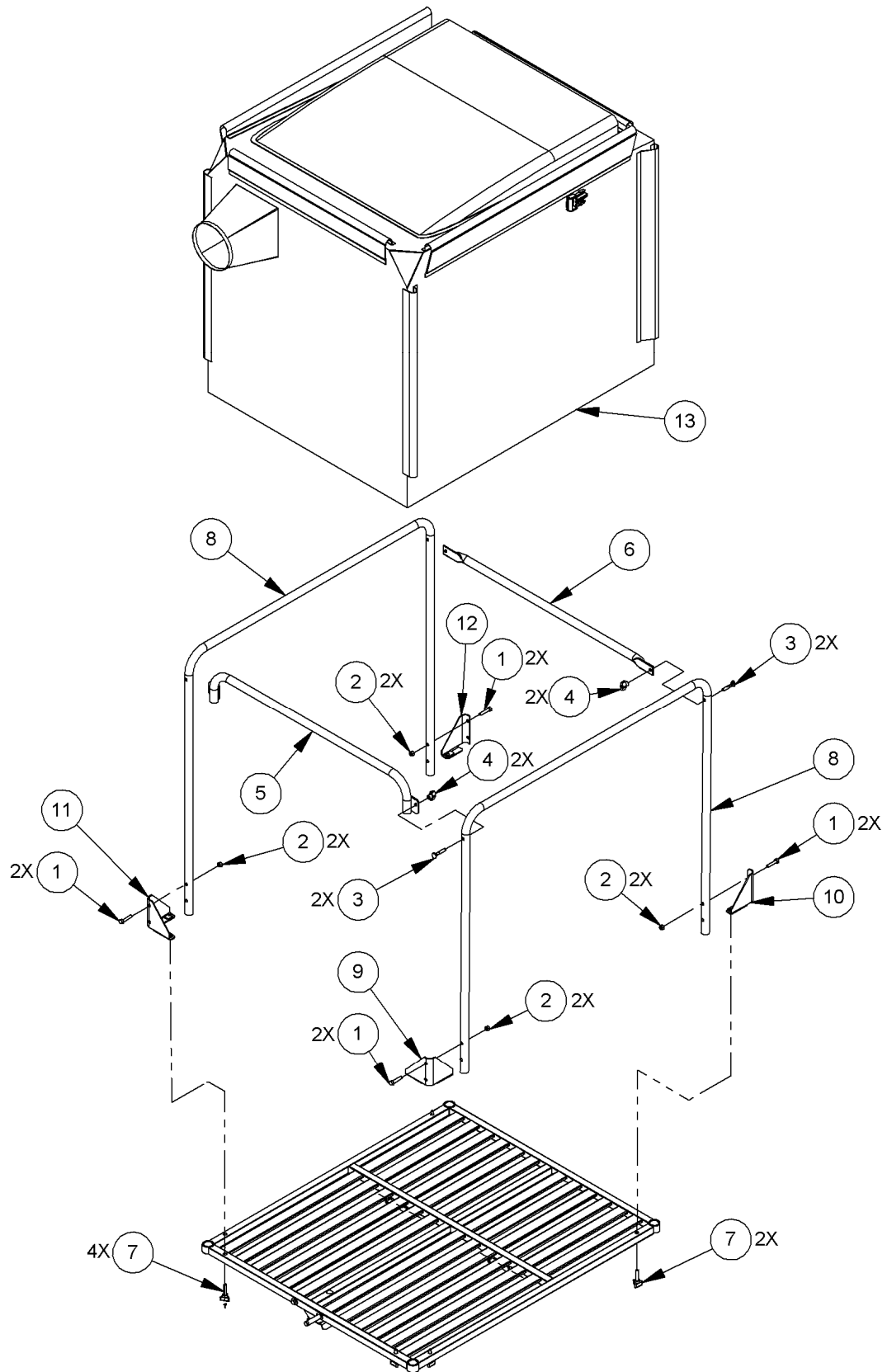

Parts List and Schematic – HOSE ASSEMBLY

NOTE: Part numbers listed are available through DR Power Equipment.

Ref#	Part#	Description
1	337951	Hose, 8" ID X 72" Long, PVC
2	342481	Cuff, Hose, 8"
3	337961	Clamp, Hose, 8", Bridge
4	337971	Clamp, Hose, 8", Thumbscrew
5	354421	Strap & Hook Set

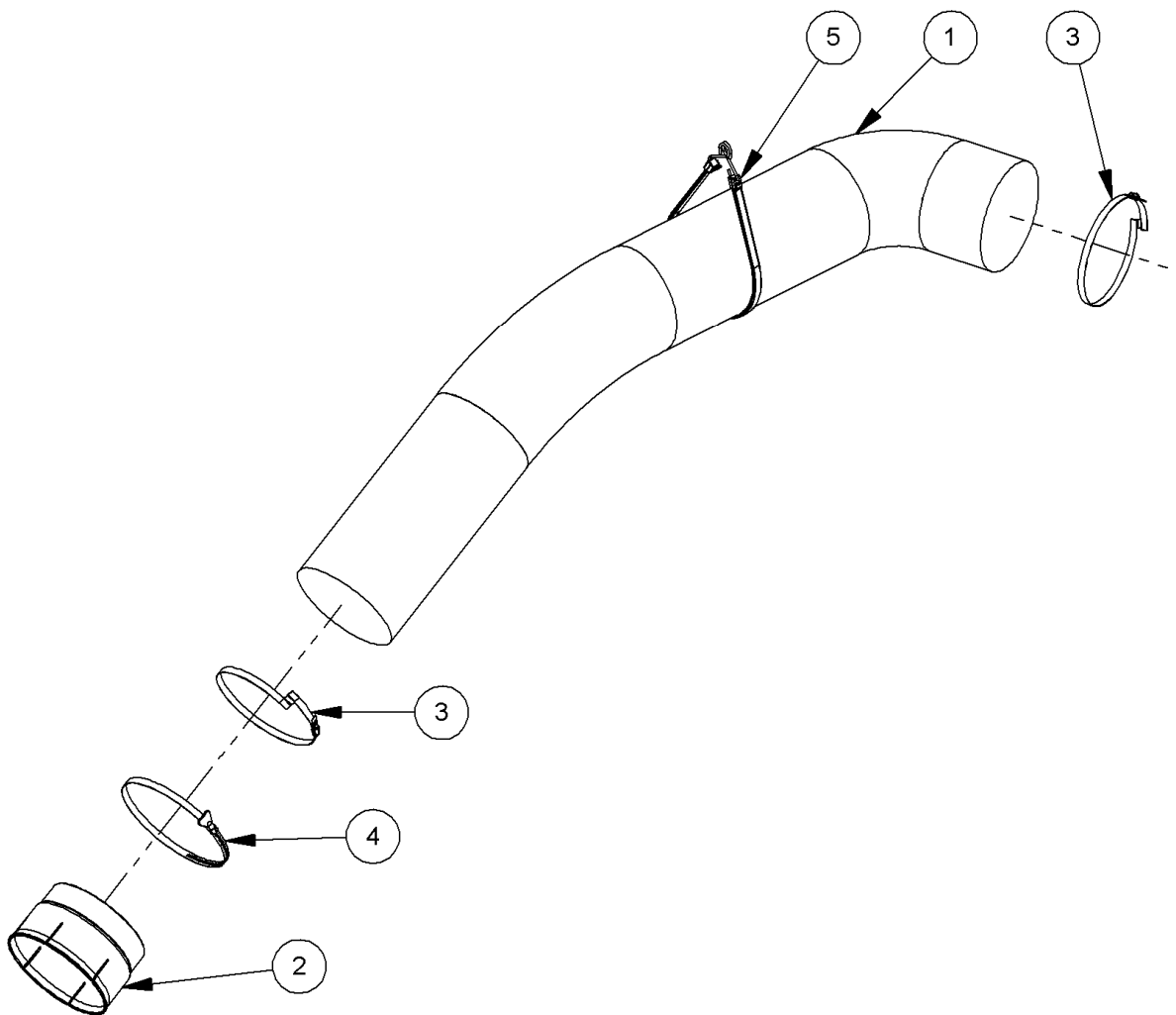

DR[®] PILOT™ LEAF and LAWN



2-Year Limited Warranty

Terms and Conditions

The DR[®] PILOT™ LEAF and LAWN VACUUM is warranted for two (2) years against defects in materials or workmanship when put to ordinary and normal consumer use; ninety (90) days for any other use.

For the purposes of all the above warranties, "ordinary and normal consumer use" refers to non-commercial residential use and does not include misuse, accidents or damage due to inadequate maintenance.

DR Power Equipment certifies that the DR[®] PILOT™ LEAF and LAWN VACUUM is fit for ordinary purposes for which a product of this type is used. DR Power Equipment however, limits the implied warranties of merchantability and fitness in duration to a period of two (2) years in consumer use, ninety (90) days for any other use.

The 2-Year Limited Warranty on the DR[®] PILOT™ LEAF and LAWN VACUUM starts on the date the machine ships from our factory. The 2-Year Limited Warranty is applicable only to the original owner.

The warranty holder is responsible for the performance of the required maintenance as defined by the manufacturer's owner's manuals. The warranty holder is responsible for replacement of normally wearing parts such as the Spark Plug, and Air Filters. Accessories to the machine are not covered by this warranty.

During the warranty period, the warranty holder is responsible for the machine transportation charges, if required. During the warranty period, warranty parts will be shipped by standard method at no charge to the warranty holder. Expedited shipping of warranty parts is the responsibility of the warranty holder.

SOME STATES DO NOT ALLOW LIMITATIONS ON THE LENGTH OF IMPLIED WARRANTIES, SO THE ABOVE LIMITATIONS MAY NOT APPLY TO YOU.

DR Power Equipment shall not be liable under any circumstances for any **incidental or consequential damages or expenses** of any kind, including, but not limited to, cost of equipment rentals, loss of profit, or cost of hiring services to perform tasks normally performed by the DR[®] PILOT™ LEAF and LAWN VACUUM.

SOME STATES DO NOT ALLOW THE EXCLUSION OR LIMITATION OF INCIDENTAL OR CONSEQUENTIAL DAMAGES, SO THE ABOVE LIMITATIONS MAY NOT APPLY TO YOU.

THIS WARRANTY GIVES YOU SPECIFIC LEGAL RIGHTS, AND YOU ALSO HAVE OTHER RIGHTS, WHICH VARY FROM STATE TO STATE.

Daily Checklist for the DR PILOT™ LEAF and LAWN VACUUM

WARNING

Before performing any maintenance, repairs, or inspection, you must first shut off the mower and leaf and lawn vacuum engines, wait five minutes for all parts to stop and cool, and disconnect the spark plug wire of the leaf and lawn vacuum.

To help maintain your DR PILOT™ LEAF and LAWN VACUUM for optimum performance, we recommend you follow this checklist each time you use your Vacuum.

- [] OIL: With the machine on a level surface, remove the Oil Fill Cap and check the oil level. Fill the reservoir according to the Dipstick with the recommended motor oil.
- [] GAS: Fill the gas tank with fresh, unleaded gasoline.
- [] ENGINE: It is very important to keep the Engine clean. Remove dirt and other debris from the Engine cooling fins and debris guard. A dirty Engine retains heat and can cause damage to internal Engine components.
- [] HARDWARE: Check all nuts and bolts to be sure that the components are secure.
- [] FRAME: Check all welds to be sure that the frame is intact and secure.
- [] HOSES: Inspect the Hose for holes, frayed, worn, kinked, or abraded areas. Replace a damaged or worn Hose.
- [] COLLECTOR: Empty the Collector after each use. Do not store the Leaf System with debris in the Collector.

End of Season and Storage

WARNING

Before performing any maintenance, repairs, or inspection, you must first shut off the mower and leaf and lawn vacuum engines, wait five minutes for all parts to stop and cool, and disconnect the spark plug wire of the leaf and lawn vacuum.

Note: Please refer to the Engine Owner's Manual for engine-specific procedures.

- Change the oil. Refer to your Engine Owner's Manual for detailed information.
- If your DR PILOT™ LEAF and LAWN VACUUM will be idle for more than 30 days, we recommend using a gas stabilizer. This will prevent sediment from gumming up the carburetor. If there is dirt or moisture in the gas or tank, remove it by draining the tank. Completely fill the tank with fresh, unleaded gas and add the appropriate amount of stabilizer or gasoline additive. Run the engine for a short time to allow the additive to circulate.
- Remove the spark plug and pour about 1 ounce of motor oil into the cylinder hole. Replace the plug and pull the recoil starter rope until you feel strong resistance. This will coat the piston and seat the valves to prevent moisture buildup.
- Clean or replace the air filter. Refer to your Engine Owner's Manual for detailed information.
- Clean dirt and debris from the cylinder head cooling fins, Impeller housing, debris screen, and muffler area of the engine.
- Clean out residual debris from the Hose and Collector.
- If possible, store the DR PILOT™ LEAF and LAWN VACUUM in a dry, protected area. If it is necessary to store the machine outside, cover it with a protective material (especially the Engine). Contact us at www.DRpower.com or call 1-800-DR-OWNER (376-9637) to purchase a cover for your DR PILOT™ LEAF and LAWN VACUUM.



800 HINESBURG ROAD, SOUTH BURLINGTON, VERMONT 05403