

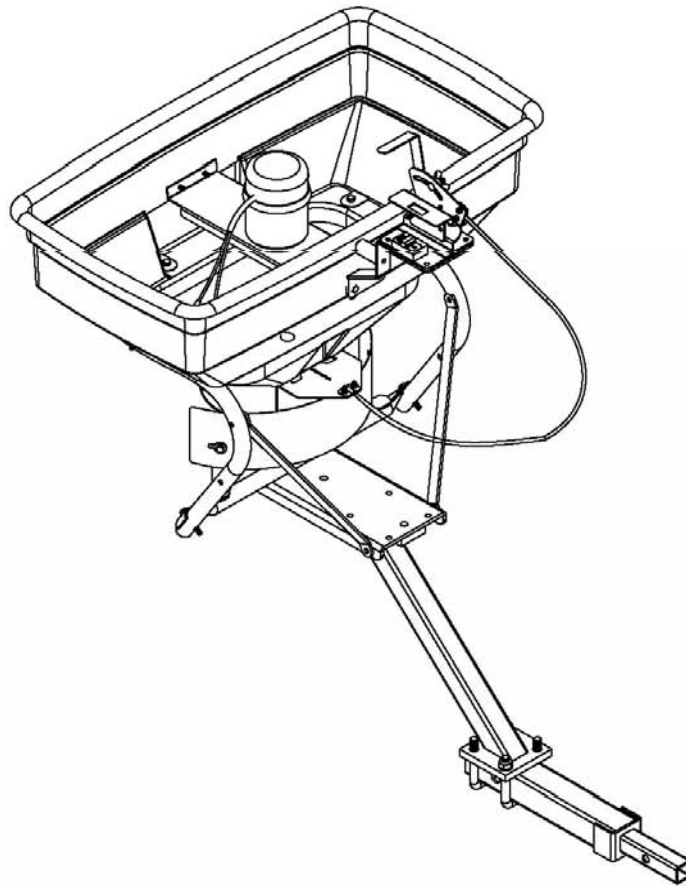

# **125LB ATV RECEIVER MOUNT SPREADER**





## **SAFETY PRECAUTIONS**



1. Be sure to wear safety glasses, a dust mask, and proper clothing to prevent coming in contact with any chemicals or dangerous materials that are being applied by this spreader.
2. Make sure to remove any contents that are in the spreader's hopper before attaching, detaching, or lifting this unit.
3. Avoid attaching and detaching this unit alone. To avoid damage to this unit and injury always have someone help attach and detach due to shape and weight of this unit.
4. Always refer to the load rating for the vehicle which is located in the vehicle's owners manual. Make sure that the unit weight of 37lbs plus the weight of the contents in the hopper do not exceed that of the vehicle's recommended load rating.
5. To avoid damage to this unit and injury NEVER overload the hopper.
6. Stay clear of all moving and spinning parts or objects of this unit
7. Always follow directions on the package of whatever you are applying with this unit.

## **Operation Instructions**

1. After assembly attach to front or rear receiver of vehicle.
2. Read and follow directions on the package of the material being spread by this unit.
3. Fill hopper with desired material to be spread by this unit not exceeding maximum load of 125lbs.
4. Adjust the handle on the gauge assembly so that it is at the desired setting. Then tighten the wing nut on the gauge assembly to set the desired opening. This allows the driver to set the opening to the same place every time while driving the vehicle. See page 3 for spread calculations.
5. Adjust handle on the gauge assembly until desired amount of spreading material is flowing out of the hopper onto the turning plate.
6. Flip rocker switch on cable assembly to on position and begin spreading.
7. Turn Rocker switch off when wanting to stop or pause spreading.
8. Empty and clean hopper when finished.

**Note: Settings for this product need to be determined by user since factors such as coarseness and density of “material used” affect the spread rates. See page 3 “rate worksheet” to calculate approximate spread rates.**

**When Rate settings are not available, follow these guidelines to calculate spread rates:**

**On the bag of material to spread, you will find recommended spread rates, usually in terms to the effect of: so many pounds will cover so many sq. ft.**

**Read these steps, then refer to the guide (worksheet page 3)**

- 1. Determine how much material to apply per 1,000 sq. ft.**
- 2. Measure off a distance of 50ft, preferably on a paved area (ie: parking lot)**
- 3. Weigh out enough material from bag to fill hopper ½ full (recommend at least ½ full hopper)  
Record weight for later.**
- 4. Set the stop at position with opening of hopper at position you feel appropriate.**
- 5. Now with hopper ½ full, bring vehicle to desired speed before start line of your 50 ft test area.  
When you arrive at start line, turn on spreader, then off at finish line**
- 6. Stop the vehicle and note the width of spread path from your testrun.**
- 7. Repeat if necessary; Then empty remaining material from hopper back to your weighing device and record new weight.**
- 8. Be sure to record your results, see below guide on page 3.**

On the bag of material to spread, you will find recommended spread rates, usually in terms to the effect of: so many pounds will cover so many sq. ft.

Find your Desired Application (spread) Rate

Example: To find your desired rate, divide the area (sq. ft.) that bag of material covers by the weight of the bag of material itself. Then multiply by 1,000.

**Example: 25lb bag / 2000 sq ft coverage = .0125**

**.0125 x 1,000 = 12.5 (12.5 is your desired lbs per 1,000 sq. feet)**

**Record Desired Rate = (lbs per 1,000 sq. ft.) \_\_\_\_\_**

**TEST RUN to DETERMINE SPREAD RATE:**

- **Determine lbs (weight) of Material in Hopper for Test Area**

\_\_\_\_\_ **Weight of Material put into Hopper**

(Example: pour a 25lb bag into spreader)

(-) \_\_\_\_\_ **Subtract Weight of Material in Hopper (After Test Area is spread)**

(=) \_\_\_\_\_ **Weight of Material Used (will be used below)**

- **Test Area Measurements**

\_\_\_\_\_ **Length of Test Area (Recommend: 50 ft)**

(x) \_\_\_\_\_ **Width of Spread Area**

(=) \_\_\_\_\_ **Total Spread Area**

**Determine Rate of Spread**

**Divide the Weight of Material Used in #2, by your Total Spread Area in #3.**

**Weight of Material Used/Total Spread Area = lbs per sq. ft.**

**Example: 2 lbs / 500 ft = .004**

**Multiply lbs per sq ft (x)1000 = \_\_\_\_\_ lbs per 1000 sq ft**

**Example: .004 x 1000 = 4**

**Compare these results to your desired application rate in #1.**

**Adjust the rate setting stop on the spreader accordingly and run test area again.**

**Example: Adjust 2 times more open to achieve double the rate of test.**

**Now you should approx. match your desired application in #1.**

**Repeat the process if necessary until you achieve your desired application rate.**

Settings and guidelines furnished on this Rate Worksheet are intended as a guide only. Variations in materials applied, ground roughness, speed of operator, may affect rate. There is no warranty as to the rate of coverage derived from above guidelines.

## Carton Contents

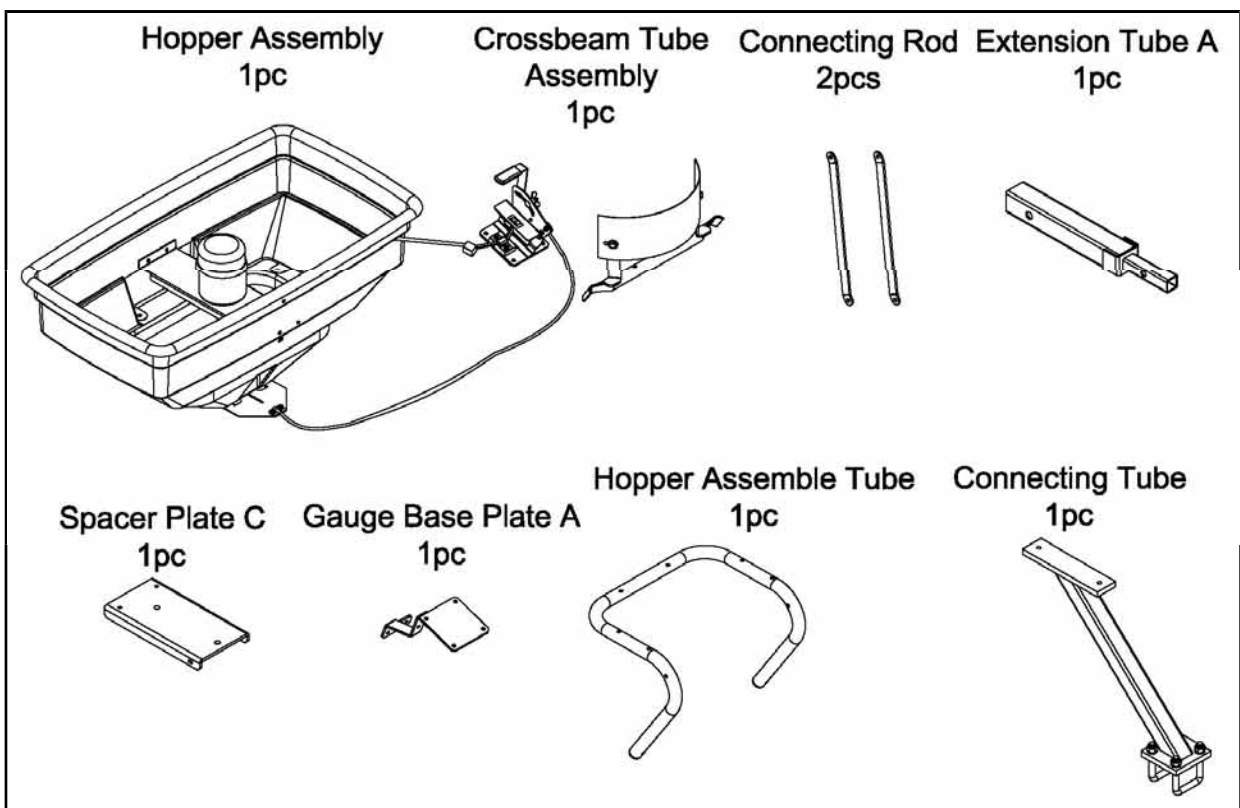
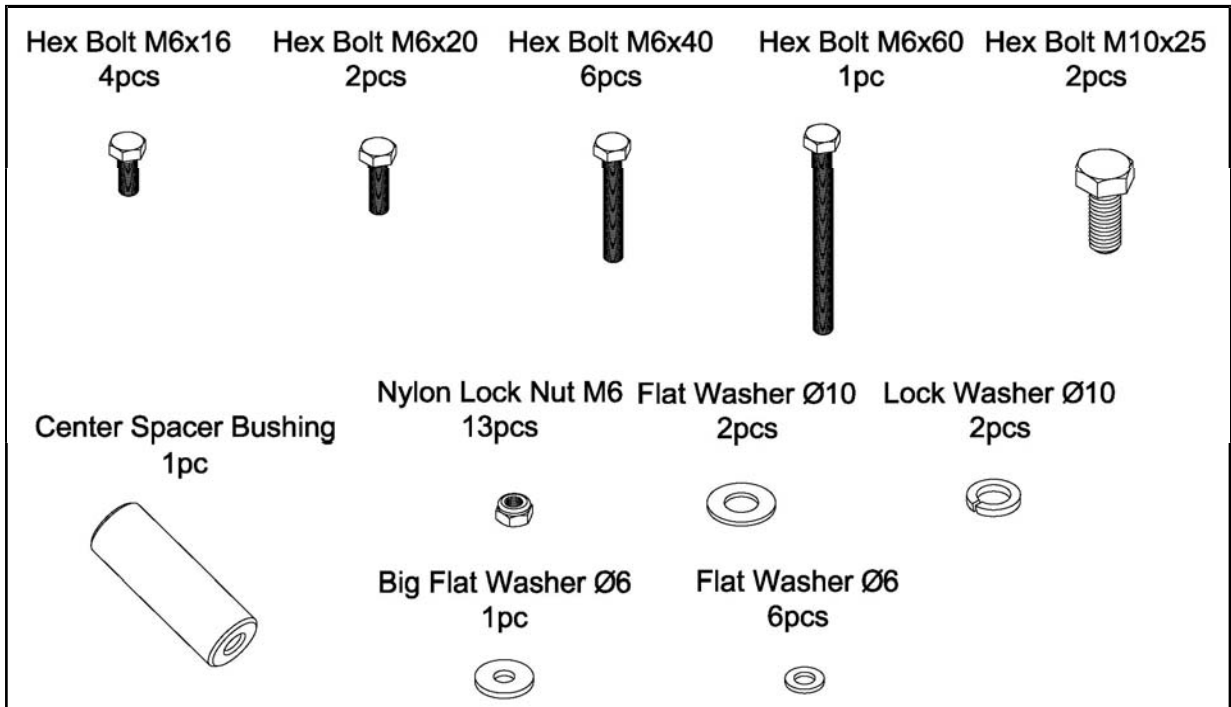

**NOTE:** If you have questions, problems, or missing parts please call our customer service before returning to your retailer. Contact us at [www.DRpower.com](http://www.DRpower.com) or call 1-800-DR-OWNER (376-9637) for assistance.

# Assembly Instructions

## Step 1:

1. Connect the deflector plate (#16) to the crossbeam tube (#17) using hex bolt M6x16 (#5), hex lock nut M6 (#15) and big flat washer Ø6 (#4). And then tighten them.
2. Connect the crossbeam tube (#17), connecting rod (#18) and hopper assemble tube (#14) using hex bolt M6x40 (#3), hex lock nut M6 (#15) and flat washer Ø6 (#50). Don't tighten them.

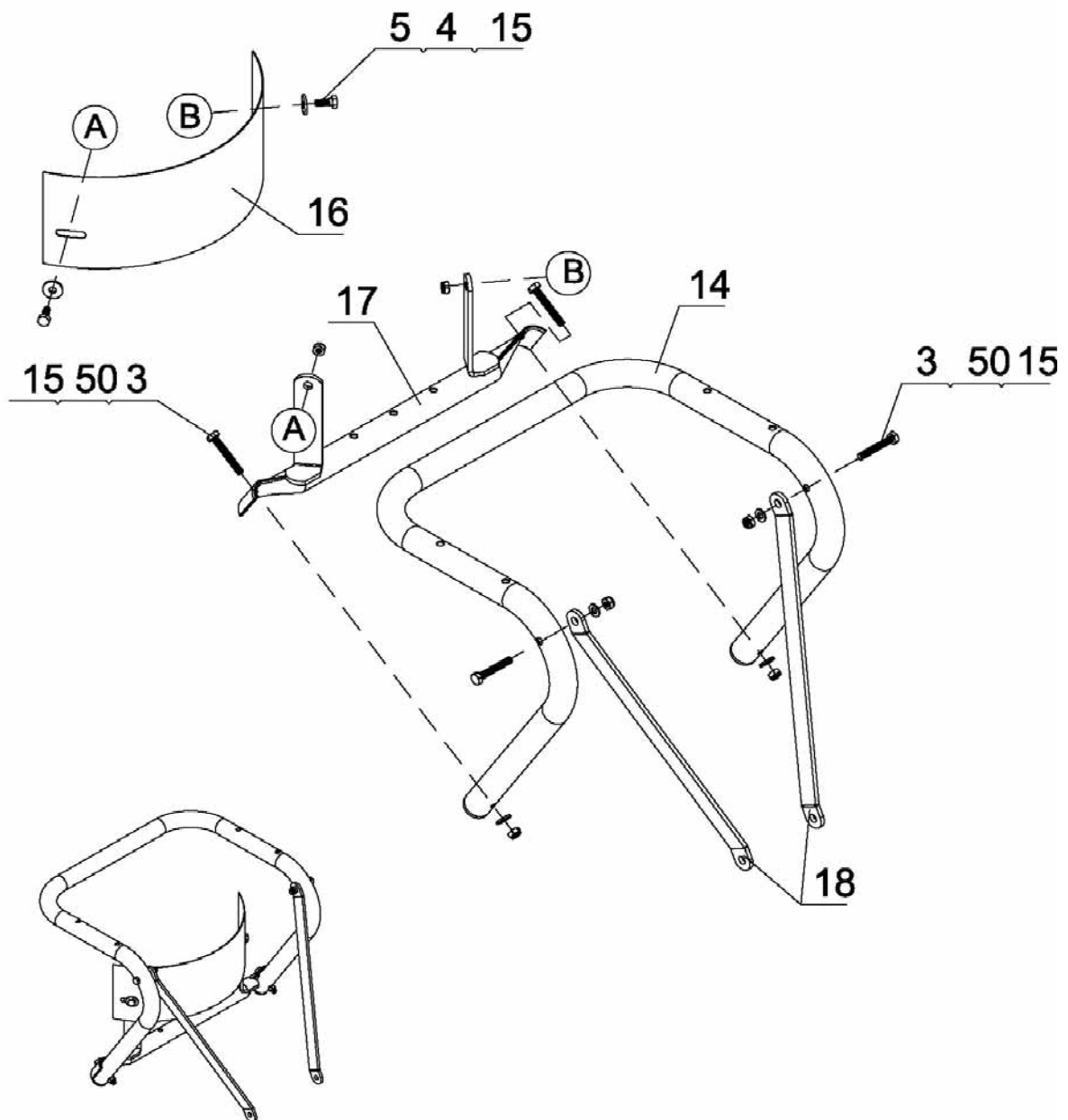

Step 2:

Assemble the connecting tube assembly (#25) and extension tube (#28) using “U” bolt (#29), lock washer  $\text{\O}12$  (#26) and hex lock nut M12 (#27), then tighten it. NOTE: extension tube (#28) can be reversed to fit 1.25” or 2” receiver (see step 7 for more detail.)

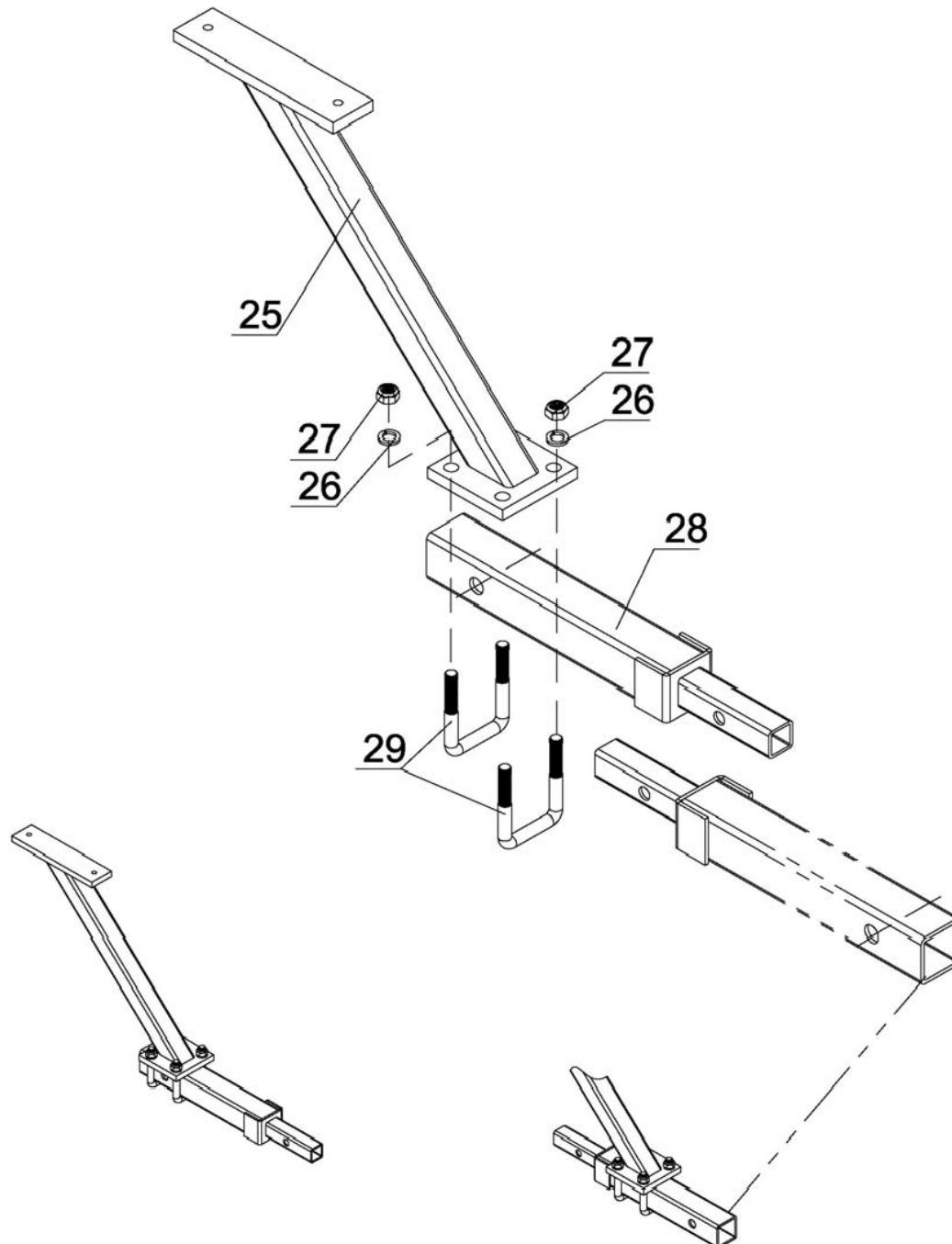

**Step 3:**

Connect the hopper assembly tube (#14) and spacer plate(#21) using hex bolt M6x40 (#3), hex bolt M6x20 (#20), hex lock nut M6 (#15) and flat washer Ø6 (#50). Fully tighten.

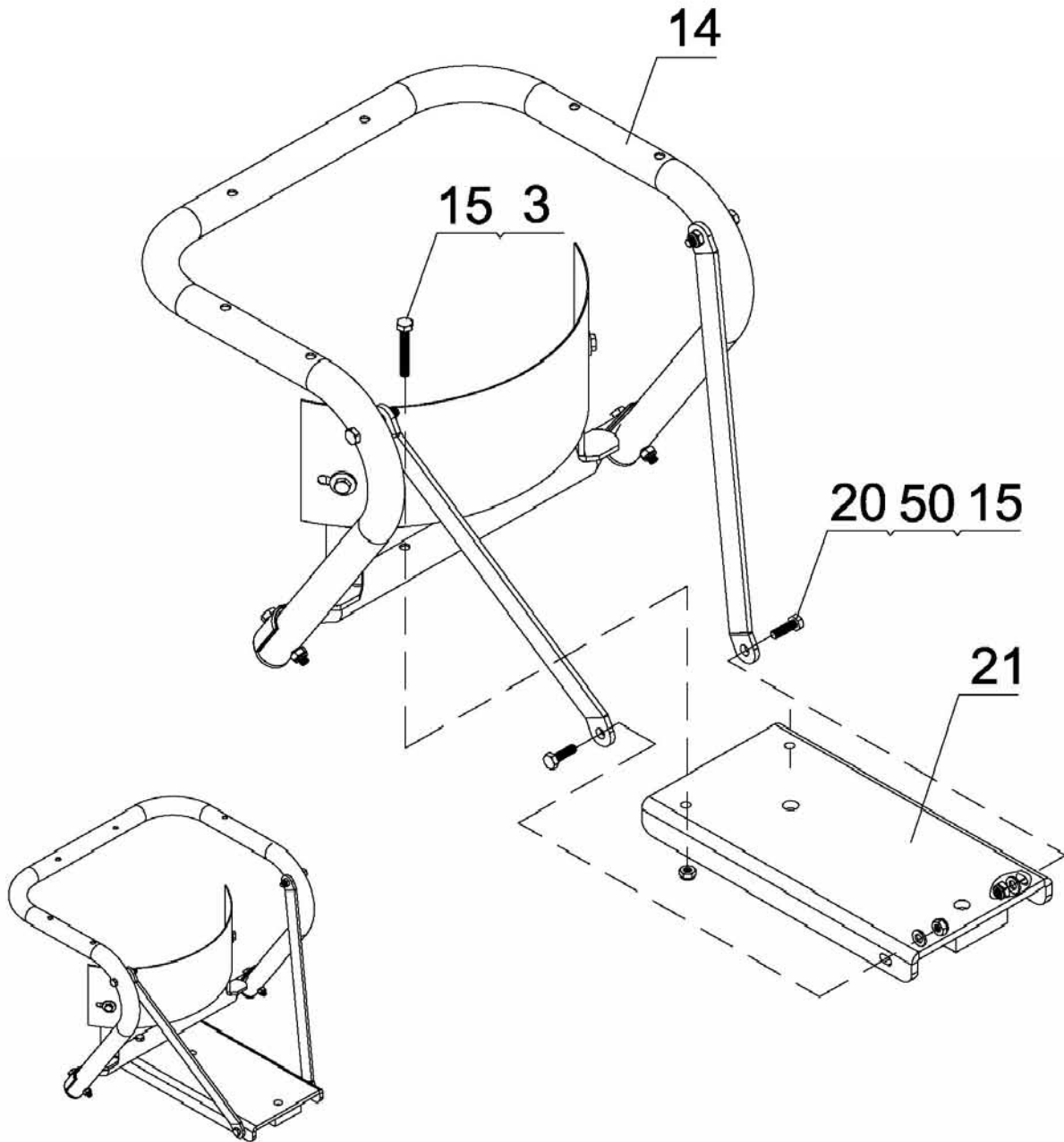



**Step 4:**

Assemble the connecting tube assembly (#25) and hopper tube assembly (#14) using hex bolt M10x25 (#22), lock washer Ø10 (#23) and flat washer Ø10 (#24). Fully tighten.

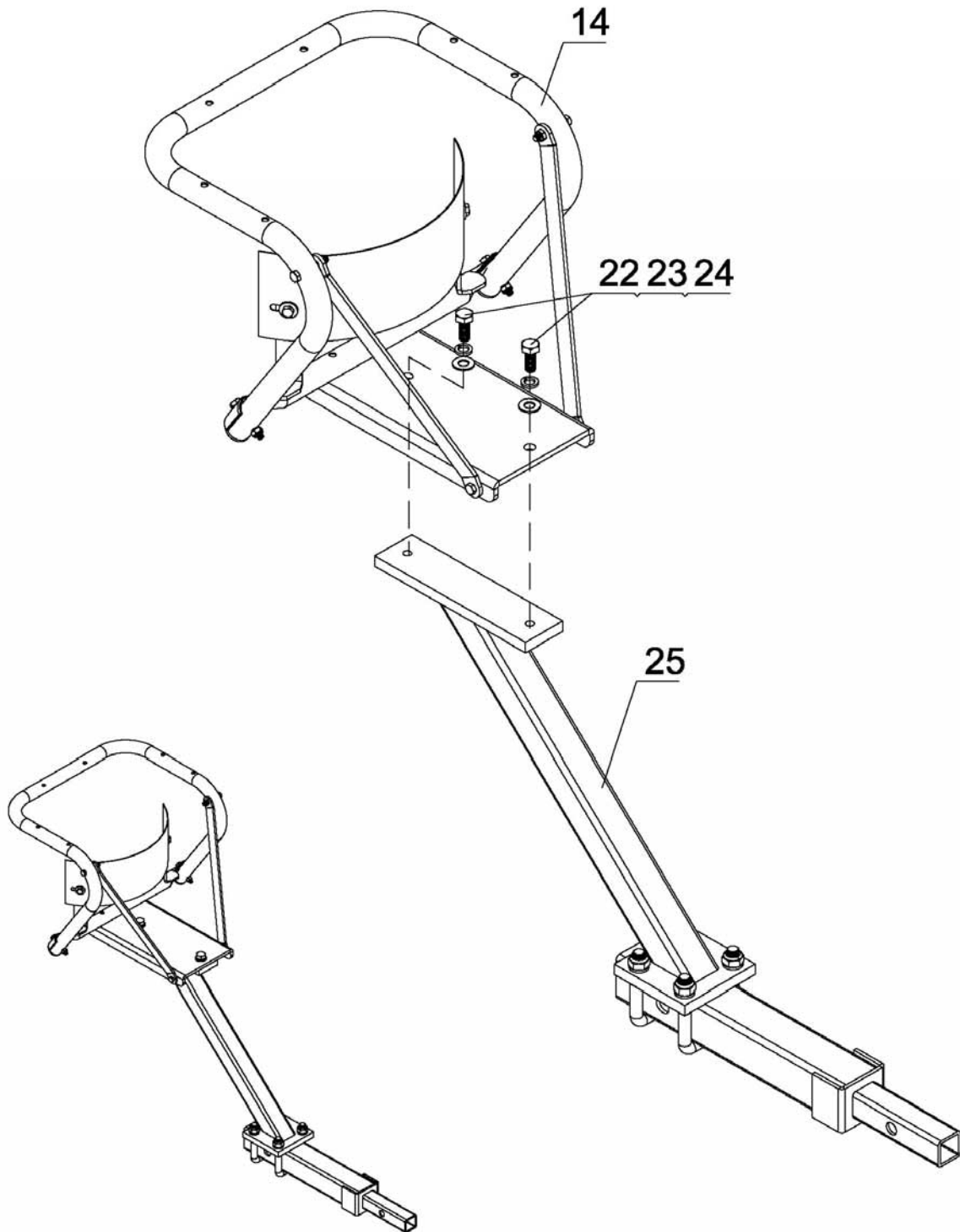

**Step 5:**

1. Pull out the switch box on the cable assembly , insert switch into the hole on the gauge base plate , then plug-in the cable, and connect the other end of the cable with the cable on the motor.
2. Secure the gauge base plate(#34) and cable assembly (#57) using screw M5x12 (#11), Spring washer Ø5 (#63) mounting the clamp press plate (#64).

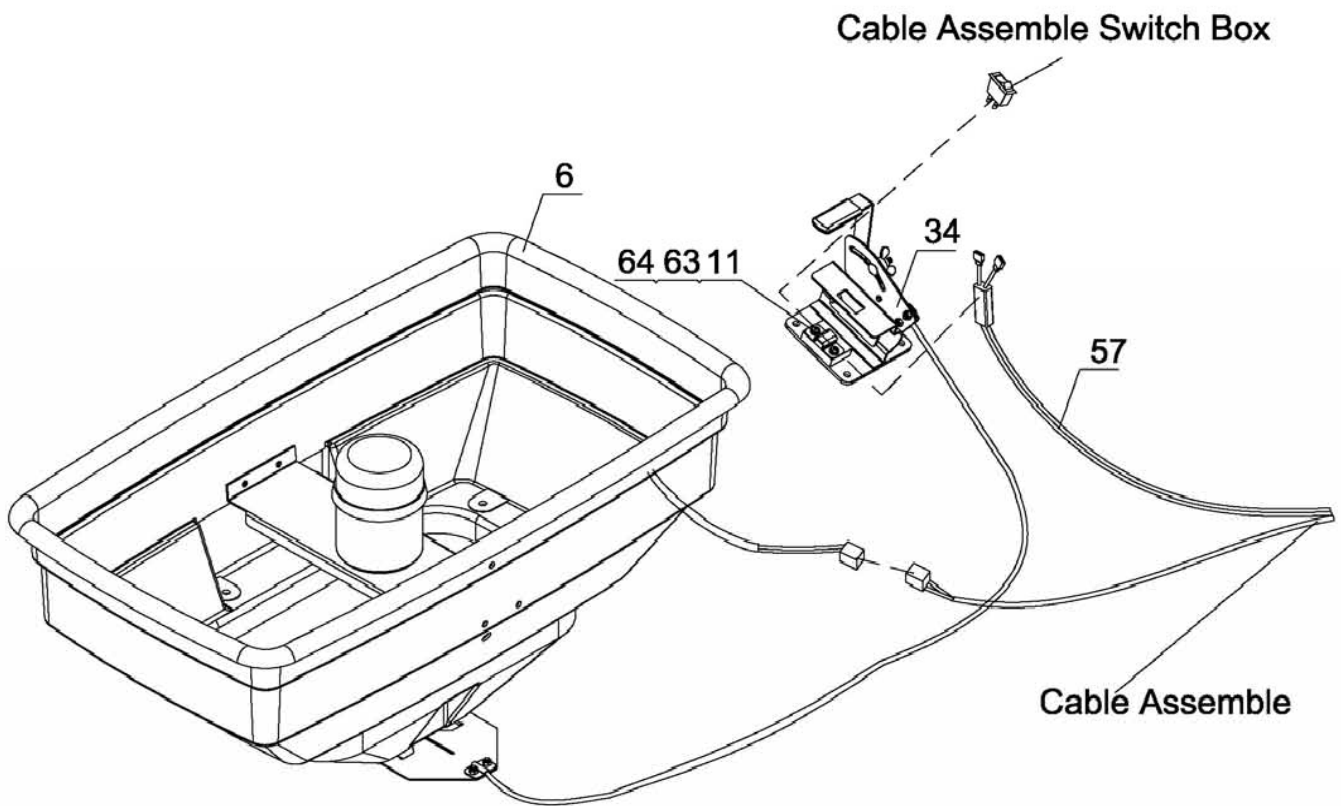

**Step 6:**

1. Connect the hopper assembly (#6) and hopper assemble tube (#14) using hex bolt M6x40 (#3),big flat washerØ6(#4) and hex lock nut M6 (#15), then tighten.
2. Connect the gauge base plate(#31) center spacer busing(#30) and hopper assembly (#6) using hex bolt M6x60(#60), big flat washer Ø6 (#4) and hex lock nut M6 (#15), then Connect the lower hole of gauge base plate (#31) and hopper assembly (#6) using hex bolt M6x16(#5) and hex lock nut M6 (#15). Then tighten all the bolts.
3. Attach the gauge base plate assembly (#34) onto gauge base plate (#31) using hex bolt M6x16(#5) and hex lock nut M6 (#15). Then tighten.

**Please note: don't disassemble the bolts and nuts here firstly. Insert the bolts and nuts on the other side, then tighten here.**

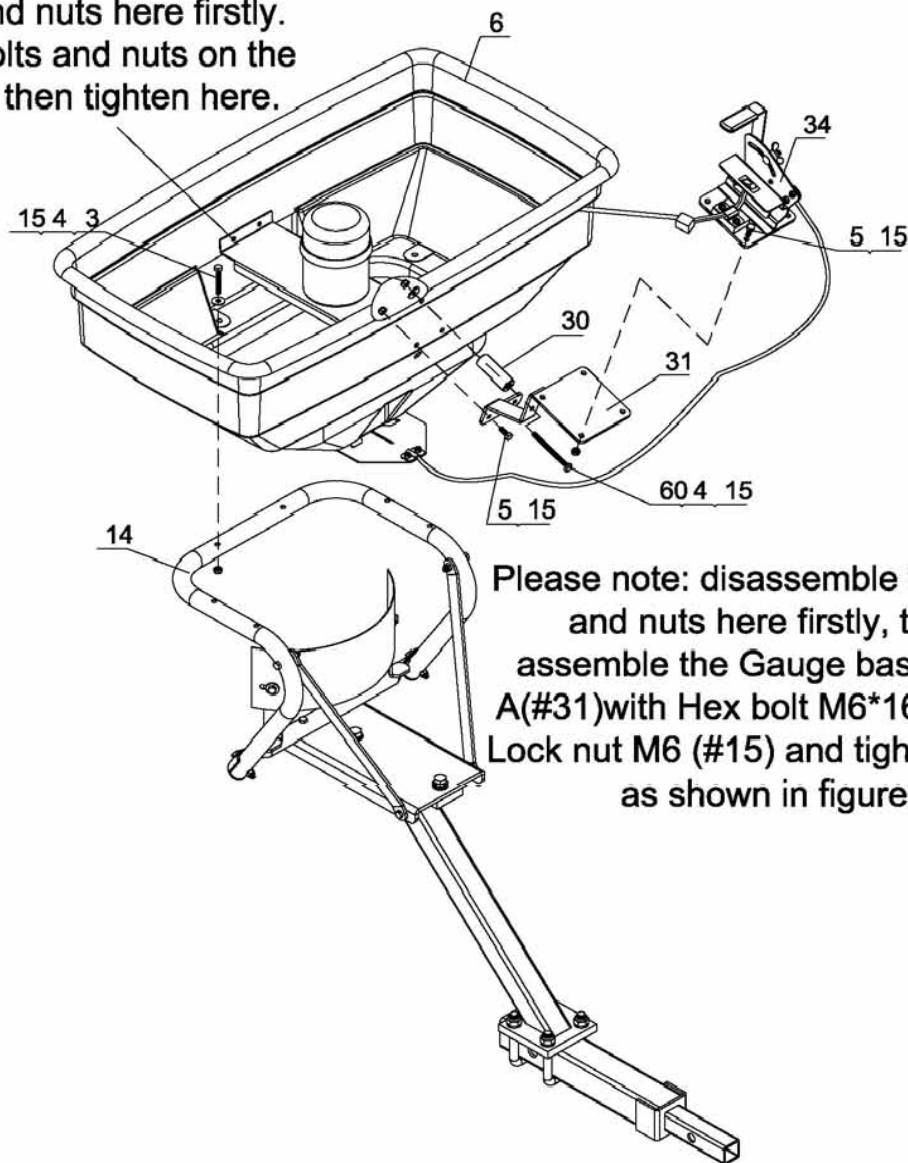

Step 7:  
Tighten all the nuts and bolts.

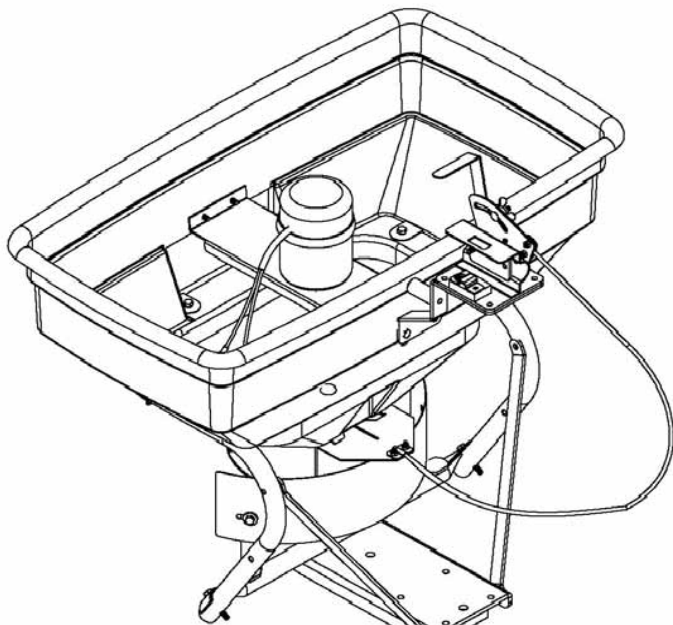

**This 1.25"x1.25" receiver tube  
fits into 1.25" standard  
receiver hitch-ATV or UTV**

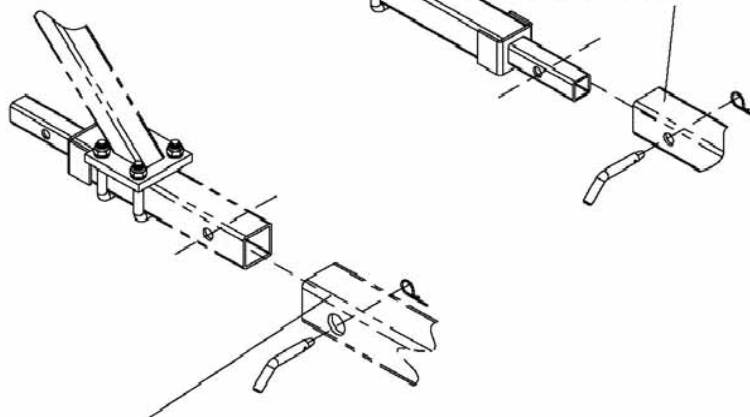

**This 2"x2" receiver tube fits  
into any 2" standard receiver  
hitch-ATV or UTV**

# Exploded Diagram

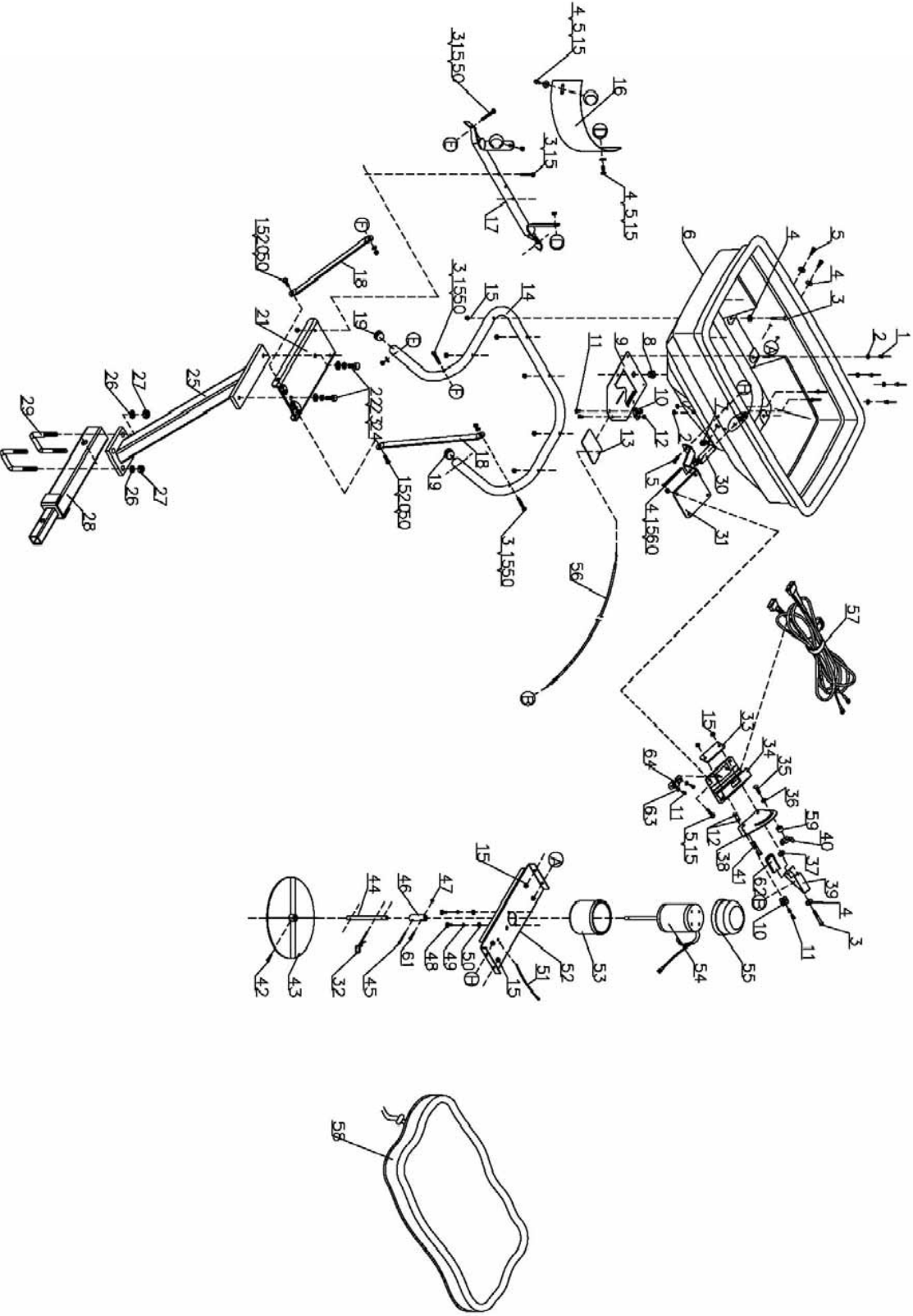

# Part List

REF#	DESCRIPTION	PART #	QTY
1	RivetΦ5x13	41270	6
2	Big Flat WasherΦ5	41271	6
3	Hex Bolt M6x40	41272	13
4	Big Flat WasherΦ6	41273	12
5	Hex Bolt M6x16	41274	10
6	Hopper Assembly	41275	1
7	Wire Clamp	41276	1
8	Shaft Bushing	41277	1
9	Fixed Adjustable Plate	41278	1
10	Link Clamp Press Plate	41279	2
11	Screw M5x12	41280	6
12	Nylon Lock Nut M5	41281	4
13	Active Adjustable Plate	41282	1
14	Hopper Assemble Tube	41283	1
15	Nylon Lock Nut M6	41284	27
16	Deflector A	41285	1
17	Crossbeam Tube Assembly	41286	1
18	Connecting Rod	41287	2
19	Tube End CapΦ25X13	41288	2
20	Hex Bolt M6X20	41289	2
21	Spacer Plate C	41290	1
22	Hex Bolt M10x25	41291	2
23	Lock Washer Φ10	41292	2
24	Flat Washer Φ10	41293	2
25	Connecting Tube Assembly	41294	1
26	Lock Washer Φ12	41295	4
27	Hex Lock Nut M12	41296	4
28	Extension Tube A	41297	1
29	"U"Bolt	41298	2
30	Center Bushing	41299	1
31	Gauge Base Plate A	41300	1
32	R Pin	41301	1

REF#	DESCRIPTION	PART #	QTY
33	Fixed Plate	41302	1
34	Gauge Base Plate	41303	1
35	Step Bolt M6X25	41304	1
36	External Teeth Lock Washer Φ8	41305	1
37	Nylon Washer	41306	1
38	Gauge & Level Assembly	41307	1
39	Adjustable Handle	41308	1
40	Wing Nut	41309	1
41	Hex Bolt M6x35	41310	1
42	Screw M4X20	41311	1
43	Impeller	41312	1
44	Shaft Φ10x135	41313	1
45	Cotter Pin Φ4x30	41314	1
46	Shaft Connecting Tube	41315	1
47	Nylon Lock Nut M4	41316	1
48	Screw M6x16	41317	2
49	Lock Washer Φ6	41318	2
50	Flat Washer Φ6	41319	8
51	Ribbon	41320	1
52	Motor Assemble Plate	41321	1
53	Motor Cover	41322	1
54	Motor	41323	1
55	Motor Cap	41324	1
56	Adjustable Rod Assembly	41325	1
57	Cable Assembly	41326	1
58	Rain Cover	41327	1
59	Spacer Bushing	41328	1
60	Hex Bolt M6x60	41329	1
61	Screw M4x25	41330	1
62	Handle Grip	41331	1
63	Spring Washer Φ5	41332	2
64	Link Clamp Press Plate A	41333	1

For replacement parts and technical questions, please contact us at [www.DRpower.com](http://www.DRpower.com) or call **1-800-DR-OWNER (376-9637)** for assistance.

**WARRANTY**  
***Two-year limited warranty***



**75 Meigs Rd, PO Box 25  
Vergennes, VT 05491**