

# **DR CHIPPER**

## ***Operating & Assembly Instruction Manual***

**Model: 18.0 HP**

**C18NH-CHP**



This manual contains information concerning proper and improper operating procedures, warnings, maintenance, troubleshooting, assembly, and tips. Everyone who operates this machine should read these instructions and be thoroughly familiar with them.

---

## SECTION I - SAFETY

---



**This symbol points out important safety instructions**, which, if not followed, could endanger the personal safety and/or property of yourself and others. Read and follow all instructions in this manual before attempting to operate your chipper. Failure to comply with these instructions may result in personal injury. When you see this symbol - **heed its warning**.

**THIS MACHINE IS CAPABLE OF INFLICTING SERIOUS INJURY IF OPERATED IMPROPERLY -- READ WARNINGS & CAUTION LABELS.**

### INTENDED USE

**Never** use your chipper for any other purpose than chipping limbs it is designed for this use and any other use may cause serious injury.



**DANGER: *Rotating cutting blade.***

Keep hands and feet out of inlet and discharge opening while machine is running.

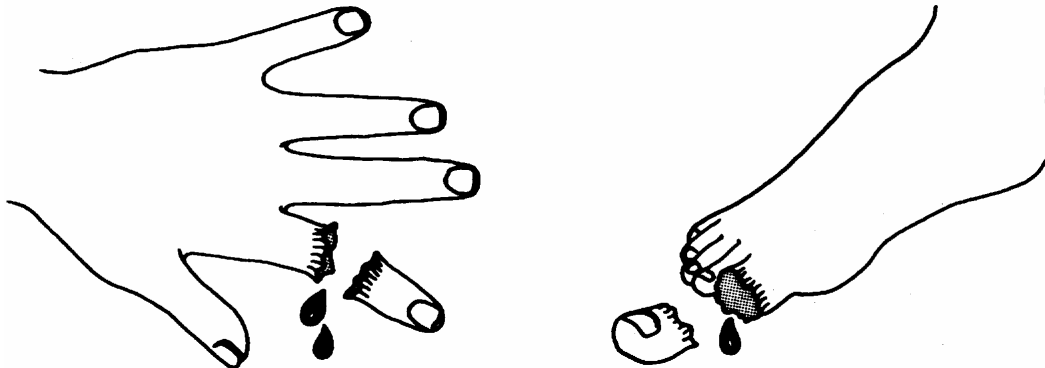

**DANGER:** This machine can **CRUSH, GRIND, CUT**, and **SEVER** parts of your body if they enter the inlet or discharge area of your chipper.



**DANGER:** Your chipper was built to be operated according to the rules for safe operation in this manual. **As with any type of power equipment, carelessness or error on the part of the operator can result in serious injury.** If you violate any of these rules, you may cause serious injury to yourself or others.



**WARNING:** The Engine Exhaust from this product contains chemicals known to the state of California to cause cancer, birth defects or other reproductive harm.

## GENERAL OPERATION

- Read this owner's manual carefully in its entirety before attempting to assemble this machine. Read, understand, and follow all instructions on the machine before operation. Be completely familiar with the controls and the proper use of the machine before operating it. Keep this manual in a safe place for future and regular reference and for ordering replacement parts.
  - Your chipper is a powerful tool, not a plaything. Therefore, exercise extreme caution at all times. Your unit has been designed to chip. Do not use it for any other purpose.
  - Never allow children under the age 16 to operate the unit. Children 16 years or older should only operate the unit under close parental supervision. Only responsible individuals who are familiar with these rules of safe operation should be allowed to use your unit.
  - Always wear safety glasses or safety goggles, during operation and while performing an adjustment or repair, to protect eyes from foreign objects that may be thrown from the machine. Be sure your glasses fit properly.
  - Wear sturdy, rough-soled work shoes and close fitting slacks and shirt. Shirt and slacks that cover the arms and legs and steel-toed shoes are recommended. Secure hair above shoulders and do not wear loose clothes or jewelry that can be caught in moving parts. Never operate a unit in bare feet, sandals or sneakers. Wear gloves when feeding material into the chipper chute. Be sure your gloves fit properly and do not have loose cuffs or drawstrings.
  - Do not operate while under the use of alcohol, drugs, or medication. A clear mind is essential for safety.
  - Do not allow anyone who is not alert to operate this machine.
  - The machine should only be operated on a level surface. Never operate your unit on a slippery, wet, muddy, or icy surface.
  - Keep the area of operation clear of all persons, particularly small children and pets. Stop the engine when they are in the vicinity of the unit. Keep work area clean and clear of branches or obstacles, which could cause you to stumble or fall.
  - Never place your hands, feet, or any part of your body in the chipper chute, discharge or near any moving part while the engine is running. Keep clear of the discharge opening at all times. If it becomes necessary to push material into the chipper chute, use a small diameter stick, NOT YOUR HANDS.
  - Keep your face and body back from chipper chute to avoid accidental bounce back of any material.
  - Do not attempt to chip material larger than specified in the manual. Personal injury or damage to the machine could result.
  - If it is necessary for any reason to unclog the feed intake or discharge openings or to inspect or repair the machine where a moving part can come in contact with your body or clothing, stop the machine and allow it to cool. Disconnect the spark plug before attempting to unclog, inspect or repair.
  - When feeding material into this equipment, be extremely careful that pieces of metal, rocks, or other foreign objects are not included. Personal injury or damage to the machine could result.
  - Do not allow an accumulation of processed material to build-up in the discharge area as this will prevent proper discharge and can result in kickback from the chipper chute.
  - If the cutting mechanism strikes a foreign object or if your machine should start making an unusual noise or vibration, immediately stop the engine and allow the machine to come to a complete stop. Disconnect the spark plug wire and move it away from the spark plug.
- Take the following steps:
- a. Inspect for damage.
  - b. Repair or replace any damaged parts.
  - c. Check for any loose parts and tighten to assure continued safe operation.
- Muffler and engine become hot and can cause a severe burn. Do not touch.
  - Do not allow any part of the engine, especially around the cooling fans and muffler, to become clogged with leaves, oil, grease or any other combustible material.
  - Do not operate engine if air cleaner or cover over carburetor air-intake is removed, except for adjustment. Removal of such parts could create a fire hazard.
  - Keep all other guards and safety devices in place and operating properly.
  - Do not use the unit with the chipper hopper removed.
  - Only use accessories approved for this machine by the manufacturer. Read, understand, and follow all the instructions provided with the approved accessory.

- Only operate unit in good daylight. Do not operate unit at night or in dark areas where your vision may be impaired.
- If situations occur which are not covered by this manual, use care and good judgment. Contact your dealer for assistance.

## CHILDREN

- Tragic accidents can occur if the operator is not alert to the presence of small children.
  - Keep children out of the work area and under the watchful eye of a responsible adult other than the operator.
  - Be alert and turn the unit off if a child enters the area.
  - Never allow children under the age of 16 to operate the chipper.

## REPAIR AND MAINTENANCE SAFETY

- Use extreme care in handling gasoline and other fuels. They are extremely flammable and the vapors are explosive.
- Store fuel and oil in approved containers, away from heat and open flame, and out of the reach of children. Check and add fuel before starting the engine. Never remove gas cap or add fuel while the engine is running. Allow engine to cool at least two minutes before refueling.
- Replace gasoline cap securely and wipe off any spilled gasoline before starting the engine as it may cause a fire or explosion. Extinguish all cigarettes, cigars, pipes and other sources of ignition.
- Never refuel unit indoors because flammable vapors will accumulate in the area.
- Never store the machine or fuel container inside where there is an open flame or spark, such as a gas hot water heater, space heater, clothes dryer or furnace.
- To reduce fire hazard, keep engine and muffler free of debris build-up. Clean up fuel and oil spillage. Allow unit to cool at least five minutes before storing.
- Before cleaning, repairing, or inspecting, make certain the flywheel and all moving parts have stopped. Disconnect **both** spark plug wires and keep them away from the spark plugs to prevent accidental starting. Do not use flammable solutions to clean air filter.
- Check the blade and engine mounting screws at frequent intervals for proper tightness. Also visually inspect blade for wear or damage. Replace the blades with parts, which meet original equipment specifications.
- Knives should be checked for sharpness and the nuts and bolts attaching them to the flywheel for tightness every 8-10 hours of operation.
- Never tamper with safety devices. Check their proper operation regularly.
- Never run this machine in an enclosed area as the exhaust from the engine contains carbon monoxide, which is an odorless, tasteless, and deadly poisonous gas.
- Never operate your chipper in poor mechanical condition or when in need of repair. Periodically check and keep all nuts, bolts, and screws tight to be sure the equipment is in safe working condition. Be sure all safety guards and shields are in proper position. These safety devices are for your protection.
- Inspect the belt each time you use the unit. Look for damage, worn areas or tears. Do not use the unit if this condition exists.
- If your machine strikes any foreign object or starts making an unusual noise or vibration, immediately shut off engine, disconnect spark plug wire from spark plug, and allow all moving parts to come to a complete stop. Inspect for damage and repair and or replace damaged parts. Check for and tighten any loose parts.
- Do not tamper with the engine's governor setting. The governor controls the maximum safe operation speed and protects the engine. Over-speeding the engine is dangerous and will cause damage to the engine and to the other moving parts of the machine. See your authorized dealer for engine governor adjustments.

**BEFORE STARTING ENGINE, ALWAYS CHECK OIL LEVEL!**

- Only operate your chipper from the operator zone.
- Know how to turn your unit off.
- Never move your chipper or leave it unattended with the engine running.
- Follow engine owner's manual for engine maintenance and repair.

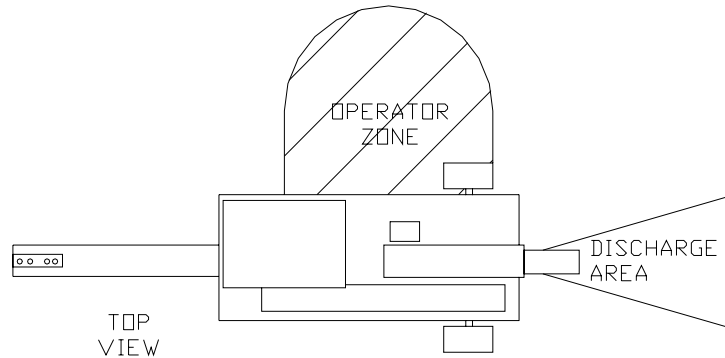

### YOUR RESPONSIBILITY

- Restrict the use of this power machine to persons who read, understand and follow the warnings and instructions in this manual and on the machine.

SAVE THESE INSTRUCTIONS  
FOR FUTURE REFERENCE.



**HAZARD:** This unit is equipped with an internal combustion engine and should not be used on or near any unimproved forest-covered, brush-covered or grass-covered land unless the engine's exhaust system is equipped with a spark arrester meeting applicable local or state laws (if any). If a spark arrester is used, the operator should maintain it in effective working order.

In the State of California, the above is required by law (Section 4442 of the California Public Resources Code). Other states may have similar laws. Federal laws apply on federal lands. A spark arrester for the muffler is available through your Briggs & Stratton servicing dealer.

---

## SECTION II - ASSEMBLY INSTRUCTIONS

---

### PACKAGE CONTENTS

SKID	PARTS BOX	BOLT BAG
CHIPPER	CHIPPER HOPPER	4 EA – 5/16-18 X ¾" CARRIAGE BOLTS
TOW BEAM	HITCH PLATE	3 EA – 5/16-18 X 1" HHCS
PARTS BOX	GLASSES	7 EA – 5/16-18 NYLOCK NUT
	OWNER'S MANUAL	4 EA – 5/16 USS FLATWASHER
	ENGINE MANUAL	1 EA – 1/4 –20 X 2" U-BOLT
	BOLT BAG	2 EA – ¼-20 NYLOCK NUT
		1 EA – 3/32 HAIR COTTER PIN
		1 EA – ENGINE KEY

### TOOLS REQUIRED FOR ASSEMBLY

- 7/16" Wrench or Socket - 2 required
- 1/2" Wrench or Socket - 2 required

### STEP I – UNPACKING AND CHECKING CONTENTS

1. Remove the all items from the crate.
2. After unpacking the crate, compare the contents with the list above.
3. If any parts are missing, contact Country Home Products at 800-376-9637.
4. Assembly should be done on a clean, level surface.

### STEP II – ASSEMBLY

1. Assemble chipper hopper (item #15, pg 18) to machine using four each 5/16"-18 x 3/4" carriage bolts, 5/16"-18 nylock nuts and 5/16" flatwashers. Put head of bolt inside hopper with threads sticking out. Tighten all hardware with a ½" wrench.
2. Attach the tow beam (item #5, pg 16) to the axle of the machine by putting the u-bolt (item #36, pg 16) from the bolt bag around the axle and through the two holes in the tow beam per the picture on page 16. Secure with two ¼-20 nylock nuts.
3. Attach the center of the tow beam to the front of the frame as shown on page 16 with a 5/16-18 x 1" HHCS and a 5/16-18 nylock nut.
4. Attach the hitch arm (item # 37, pg 16) to the tow beam as shown on page 16 with two 5/16-18 x 1" HHCS (item #35, pg 16) and two 5/16-18 nylock nuts (item #34, pg 16).
5. If you have purchased the optional stand (item #6, pg 16), slide it up through the holes in the tow beam (item #5) and the hitch arm (item #37) and secure with the hair cotter pin (item #25).
6. Connect the black battery cable to the negative (-) side of the battery using the hardware attached to the end of the battery cable. Tighten with wrenches.
7. Service the engine as per the engine manual.
8. Lubricate both bearings before operating and after every 8 hours of operation with multi-purpose grease. Also check the bearing collar set screws regularly to be sure they are tight. If they are loose, reset them with EV grade loctite or equivalent - obtainable at any hardware store.

## BEFORE STARTING ENGINE, ALWAYS CHECK OIL LEVEL!

There may be a trace amount of oil in the engine from the supplier.

Fill engine with oil to the full level mark on the oil dipstick.

---

## SECTION III - OPERATION

---

### **BEFORE STARTING:** Gas and Oil Fill-Up

### **BEFORE STARTING ENGINE, ALWAYS CHECK OIL LEVEL!**

Refer to the engine owner's manual for further details regarding the engine.

**NOTE:** ENGINE IS SHIPPED *WITHOUT* OIL !! FILL CRANKCASE WITH OIL BEFORE STARTING ENGINE. Be very careful not to allow dirt to enter the engine when checking or adding oil or fuel.

#### **TO FILL OIL**

- To initially fill oil, the chipper must be in the upright position and the engine level.
- Clean around the oil dipstick.
- Remove the oil dipstick, fill the engine with oil.
- Add oil slowly and wait several minutes for oil to settle before rechecking oil level.
- Replace and tighten the oil dipstick.

#### **TO FILL GAS**

- Fill the fuel tank with fresh, clean unleaded regular automotive gasoline. (Leaded regular and unleaded or leaded premium grades of gasoline are acceptable substitutes.)
- Do not mix oil with gasoline.
- Do not use gasoline left over from last season or that has been stored for more than 30 days.

#### **TO ADD OIL**

- The Chipper must be in the upright position and the engine level.
- Clean around the oil dipstick.
- Remove the oil dipstick, wipe it clean and check oil level.
- Fill to the oil full mark on the dipstick.
- If required, add oil slowly and wait several minutes for oil to settle before rechecking oil level.
- Replace and tighten the oil dipstick.

#### **TO ADD GASOLINE**

- Shut off the engine and disconnect the spark plug wire from the spark plug. Allow the engine and muffler to cool for at least three minutes.
- Clean the area around the fuel cap and remove the cap from the fuel tank. Insert a clean funnel into the fuel tank.
- Fill the fuel tank to 1 inch below the bottom of the filler neck to provide space for any fuel expansion.
- Reinstall the fuel fill cap securely and wipe up any spilled gasoline.



**WARNING:** Do not fill closer than one inch to the top of fuel tank to prevent spills and to allow for fuel expansion. If gasoline is accidentally spilled, move unit away from area of spill. Avoid creating any source of ignition until gasoline vapors have disappeared.

**CAUTION:** Experience indicates that alcohol blended fuels (called gasohol or using ethanol or methanol) can attract moisture which leads to separation and formation of acids during storage. Acidic gas can damage the fuel system of an engine while in storage. To avoid engine problems, use fresh fuel every 30 days. Never use engine or carburetor cleaner products in the fuel tank or permanent damage may result.

**NOTE:** USE CLEAN OIL AND FUEL. STORE IN APPROVED, CLEAN, COVERED CONTAINERS. USE CLEAN FILL FUNNELS.

## ENGINE STARTING INSTRUCTIONS

- A. There is a fuel shut-off valve below the gas tank on your machine. Before starting the chipper, be sure the fuel shut-off valve is open (the tab should be vertical). When transporting and storing the chipper, close the fuel shut-off valve to prevent leakage (tab should be horizontal).
- B. Locate choke lever (ring under air cleaner approximately 8" left of starter button).
- C. Move choke lever to "FULL CHOKE POSITION" by pulling ring straight out.  
NOTE: IF RESTARTING A WARM ENGINE AFTER A SHORT SHUTDOWN, MOVE CHOKE LEVER TO "NO CHOKE POSITION".
- D. Move toggle switch lever away from "STOP" position.
- E. Push starter button to crank engine.
- F. Crank engine until it fires. When it starts, release starter button and move choke ring to "1/2 CHOKE" until engine runs smoothly and then to "NO CHOKE POSITION".

If engine falters, move choke lever to "1/2 CHOKE" until engine runs smoothly and then to "NO CHOKE POSITION" by pushing choke ring in.

NOTE: If engine fires, but does not continue to run, move choke lever to "NO CHOKE POSITION" and crank engine until it starts.

NOTE: If engine again fires, but does not continue to run, move choke lever to "FULL CHOKE" and repeat instructions C, D, and E until engine starts.

## ENGINE STOPPING INSTRUCTIONS

- Move toggle switch to "STOP" position.

Engine running speed is preset by engine manufacturer - it only runs at full speed.

**DO NOT** tamper with engine settings this could damage engine and will void engine warranty.

Whenever you operate your chipper, wearing gloves and safety glasses is required. If necessary to push material into chipping chamber, use a wood stick, never your hands or steel implements. At the end of this section, we offer additional cautions. Read and observe them.

As the engine ignition begins, the engine operates under no load until approximately 1200-1400 rpm at which speed the centrifugal clutch engages and begins driving the rotor. Proper rotor speed is in the 2400 rpm range with a plus or minus tolerance of 200 rpm.

When viewed from the pulley side of the chipper body, the flywheel runs counterclockwise. This action tends to pull materials into the chipping chamber.

Branches are fed into the side hopper for chipping. If they are thicker than 2" in diameter, feed only one branch at a time. For smaller diameter sticks and twigs, several may go together. Since the throat opening is approx. 4-1/2" square, some side shoots or side branches may have to be trimmed from the main stalk before the chipping process. Short stubs of branches may be pushed through the chipper section with the next branch. **Never** assume you know where the blade is, and try to push short branches in by hand. You don't know where it is. Be safe, keep your hands away from the chipping blade.



---

## SECTION IV - CHIPPING

---

1. To process branches, dry or green feed into the chipper hopper. It is best to clip off side twigs or limbs from the main branch. Enter one branch at a time if they are 2" or more in diameter. Green branches process quicker and easier than dry branches and soft wood is easier than hardwood. Push the branch in at the angle of the hopper and throat. Always have the removable hopper in place. Never allow your hands to enter the hopper. As the chip branch shortens, finish chipping it by shoving the stub down the chipper tube with the next branch to be chipped.
2. When chipping branches, sometimes a tail will be left at the end of the branch (usually green wood), which will increase in length as you chip and eventually rap around the shaft or bearings. To avoid this we recommend twisting the branch as you feed it into the chute. This will also improve the chipping performance.

Use common sense when using your chipper. Learn to recognize the change in sound when it is overloaded. If the machine becomes jammed by overloading or another cause, stop the engine immediately and no damage will occur. **IF YOU JAM THE UNIT AND DO NOT STOP THE ENGINE, IT WILL BURN THE BELT OR RUIN THE CLUTCH.** To free a jammed flywheel, stop the engine, remove **both** spark plug wires and remove the material left in the chipping chamber. It may be necessary to remove the deflector (item #1, pg 16) to allow easier cleaning of the machine. Make sure to replace deflector with all supplied hardware to reduce risk of injury. Check to see that the flywheel will turn freely before you start the chipper. Only your operator experience will tell you how fast to feed limbs.

**WARNING: Do not allow chips to build up within 3" of discharge chute opening. Move chipper or pile as needed. Failure to do this could result in unnecessary jamming of machine.**

**To move pile, use spade, rake, or long handle tool  
NEVER USE YOUR HANDS OR FEET!!!**

1. Never allow your hands or any part of your body or clothing inside the feed hopper or discharge area of the chipper. Use a wood stick to push material down the hopper.
2. Keep all protective guards on the machine and deflectors in place and in good working condition.
3. Always stand clear of the discharge area when the chipper is running.
4. Keep your face and body back from the feed hopper to avoid being struck by any material that may bounce back. Do not overreach, keep proper balance and footing.
5. Do not transport the chipper while the engine is running.
6. Do not refuel the engine while it is hot, warm, or running.
7. Do not cover the chipper while the muffler is still hot.

---

## SECTION V - MAINTENANCE AND STORAGE

---

**IMPORTANT: Knives should be checked for sharpness and the nuts and bolts attaching them to the flywheel for tightness every 8-10 hours of operation.**

If the cutting mechanism strikes any foreign object or if your machine should start making an unusual noise or is vibrating, stop the engine, disconnect **both** spark plug wires from the spark plug. Allow the engine to cool before you;

- a. Inspect and examine for obvious damage.
  - b. Check for loose parts, bolts, and nuts.
1. When not in use, your chipper should be stored out of the reach of children. Be sure there are no gasoline fumes in the storage area. For long periods of storage (over winter), refer to the engine owner's manual.
  2. After every 10 hours of operation, lubricate the chipper side and drive side bearings with multi-purpose lithium grease. Also, check the bearing collar set screws regularly to be sure they are tight. If they are loose, reset them with loctite 243 or equivalent obtainable at any hardware store.
  3. You will find information included referring to operation and maintenance of the chipper engine. Look it over carefully. **BE CERTAIN TO SERVICE THE ENGINE BEFORE YOU START IT.**
  4. When the steel chipping knife (item #8, pg 18) needs replacing or sharpening, refer to the section on removal and re-installation of chipper knives on page 11.
  5. Care must be exercised when sharpening the blade to maintain the correct bevel and a straight edge. When you install a knife, the clearance between knife and wear plate must be checked. This clearance or gap should be minimum 1/16", maximum 3/16" (See figure 3). To adjust this clearance, loosen the three 1/4 inch flathead bolts (item #11, pg 18) and the 1/4-20 nylock nuts (item #20, pg 18) which are located on the outside of the chipper wear plate (item #12, pg 18) next to the chipper side plate. Move the wear plate in or out as necessary and tighten the 1/4" nuts and bolts securely.
  6. Note, if the gap between chute plate and knife is excessive, you will have vibration when chipping and the blade will seem to be dull.
  7. If at any time it becomes necessary to disassemble the chipper for repairs, the chipping disc (item #3, pg 18) must be re-installed in **exactly** the same position on the shaft.

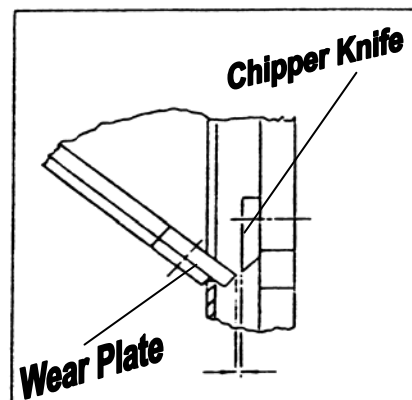

Figure 3

**BEFORE STARTING ENGINE, ALWAYS CHECK OIL LEVEL!**

## REMOVAL AND RE-INSTALLATION OF CHIPPER KNIVES

### HOW TO REMOVE THE KNIFE

1. Remove the spark plug wires from both spark plugs.
2. Remove both access covers from the chipper basic machine.
3. Rotate the chipper disc until the three countersunk screws and nylock nuts holding the blade are visible through the access doors.
4. To remove these screws do the following.
  - A. Clean out the heads of the allen screws (item #9, pg. 18) with an awl or sharp tool.
  - B. Insert a 3/16 allen wrench into the heads of the screws.
  - C. Use a 1/2" socket and ratchet to remove the nylock nut from the screws.
  - D. Remove all three screws in this manner.

### HOW TO SHARPEN AND REINSTALL THE KNIFE

#### KNIFE SHARPENING

Chipper Knives - These hardened knives must be routinely checked for sharpness. Using dull knives decreases performance and causes excessive vibration and damage to the unit. **DO NOT ATTEMPT TO SHARPEN KNIVES FREE HAND.** Knives must be parallel ground and kept in a matched set. Take the knives to a sharpening service to be sharpened. After sharpening the knives, be sure to re-gap the knives and wear plate. This gap should be a minimum of 1/16" to a maximum of 3/16".

A properly sharpened knife looks like this:

RIGHT (45°)



WRONG



#### KNIFE INSTALLATION

1. When installing new knives, be sure disc is clean before positioning knife.
2. Reinstall the screws and nylock nuts that were removed while taking the knives off.
3. Check and reset the gap between the knives and the wear plate. New knives will require the wear plate to be backed out for additional clearance before the new knives can pass.

#### WEAR PLATE

The wear plate should be kept with a square edge and free of nicks

Test the unit by turning the flywheel by hand to check for proper clearance. Watch and listen carefully for any unusual noises, clicking or vibration. If any of these are detected, inspect the machine for damage, repair or replace any damaged parts and check for any loose parts and retighten.

## INSTRUCTIONS FOR ADJUSTING OR REPLACING BELT

If the belt needs replacing or tightening, follow these instructions carefully.

1. Remove the belt guard (item #22, pg 16).
2. Check alignment of the clutch with drive pulley (item #12, pg 16) by placing a straightedge across both faces (see figure 1). If adjustment is necessary, adjust rotor pulley. **DO NOT ADJUST BY MOVING CLUTCH ON ENGINE SHAFT.**
3. Loosen engine bolts and nuts (item #32 & #34, pg 16).
4. Install the drive belt (item #17, pg 16) and tighten belt tensioner (item #28) until belt deflection is as shown in Figure 2.
5. Tighten engine mounting bolts and nuts securely.
6. Re-install the belt guard before operating your unit.

**Figure 1**

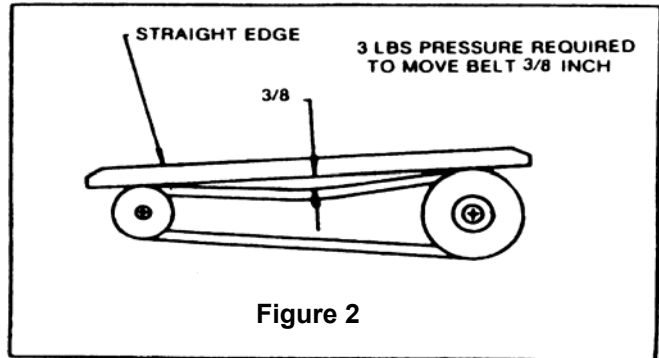
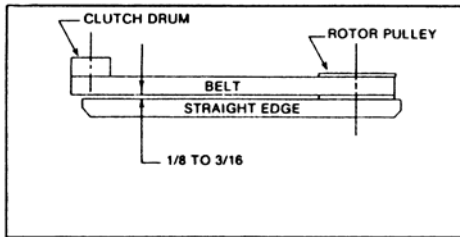

**NOTE: Check and re-tighten belt after break-in period.**

## TROUBLESHOOTING

Symptom	Problem	Correction
Clutch overheats.  Belt burns.  Flywheel won't turn.	Clutch is slipping or flywheel is jammed or stopped.	A. Immediately stop engine. B. Remove spark plug wire. C. Turn flywheel by hand to be sure it turns freely. D. Check belt tension.
Chipping action seems too slow or flywheel stalling.	Engine speed is too slow. Belts are slipping.	Run engine at full throttle. Check for loose or missing belt & tighten.
When chipping, log seems to vibrate excessively & "hammers" hands.	Knives are dull. Gap between knife & wear plate is too great.	Remove knife & sharpen - be sure to maintain same bevel of 45 degrees. Adjust gap as per instructions.
Chipper knives move over and are striking chipper side plate.	Taper lock bushing is loose. Setscrews in flywheel shaft bearings are loose or missing.	If key in taper lock bearing is too deep, file key to seat properly. Reset the proper knife gap & tighten setscrews.
Engine runs but flywheel doesn't rotate.	Inner shoes of clutch worn. Retaining springs weak or broken. Loose drive belt.	Replace worn or broken clutch parts. Check belt tension. Clear chipper chamber.

## LUBRICATION AND MAINTENANCE

OPERATION TIME	PROCEDURE	COMMENTS
BREAK-IN	Change engine oil and filter after first 5 hours. Check belt tension. Check all nuts and bolts for tightness.	Per manufacturer's specifications.  Adjust as required. Tighten if necessary.
8 HOURS	Check engine oil. Check chipper knives gap and edge. Clean air filter. Remove hubs from axle and grease. Grease flywheel shaft bearings. (1)	Do not over fill. See knife maintenance section. More often if needed. Anti seize compound. Good grade multi-purpose lithium grease.
40 HOURS	Change engine oil. (2) Check tire pressure. Remove and sharpen or replace chipper knives.	Per manufacturer's specifications. Add or adjust as required. See knife maintenance section.
100 HOURS	Replace belt. Change engine oil.	Order replacement part. Per manufacturer's specifications.
200 HOURS	Clean and adjust spark plug.	Per manufacturer's specifications.

(1) Two pumps of handgun. DO NOT over-grease as this may damage seal.

(2) Depending on climate and environment, lubrication may be required every 8 to 40 hours.

## ACCESSORIES FOR C18NH-CHP

Water resistant fitted cover	Order Part No. 913-0069
Stand Assembly	Order Part No. 911-0035

# CENTRIFUGAL CLUTCH INSTALLATION AND SERVICING INSTRUCTIONS FOR CLUTCH PART NUMBER 911-0236

## REMOVAL

1. Remove clutch from shaft by removing bolt and washers.
2. Slide clutch off shaft.
3. Remove key from keyway.

## INSTALLATION

1. Clean the shaft and remove any burrs.
2. Install spacer onto shaft.
3. Apply anti-seize compound to shaft.
4. Place key in keyway in shaft.
5. Slide clutch onto shaft.
6. Secure clutch with washer and bolt. Be sure to use loctite 243 on the threads of the bolt.

## MAINTENANCE

The centrifugal clutch on this machine is permanently lubricated and does not require oil or grease. Always replace shoes and springs in sets; whenever shoes are changed, replace all springs.

## DISASSEMBLY OF EXISTING CLUTCH

1. Remove retainer ring and press off drum assembly.
2. Release one hook end of spring from shoe pin. Use tape wrapped pliers to avoid nicking spring.
3. Remove shoes from hub.

## RE-ASSEMBLY

1. Locate the shoes correctly on the hub for rotation required.
2. Place one end of each spring in hole at end of shoe, stretch spring just enough to clear hole on adjacent shoe. Use tape wrapped pliers to avoid nicking spring. Avoid overstretching spring as this may damage spring. Repeat for all shoes.
3. Re-assemble drum to hub, secure with retaining ring.
4. Re-install clutch on shaft.

## CLUTCH PARTS LIST Complete Part 911-0236

Item No.	Part No.	Quantity	Description
1	911-0236-3	1	Hub Assy.
2	911-0046-4	3	Shoe
3	911-0236-5	3	Spring
4	911-0046-2	1	Drum Assy.
6	912-2644-7	2	Retaining Ring

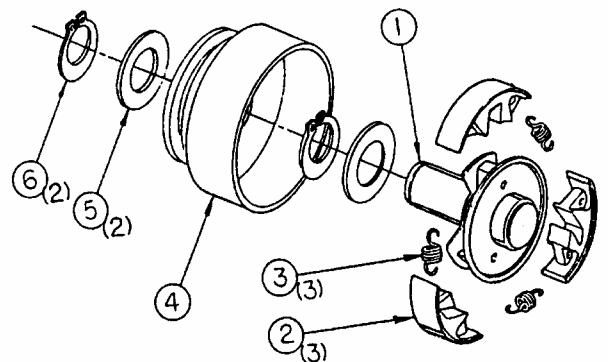

## PARTS LIST - C18NH-CHP CHIPPER

Item No.	Qty.	Part No.	Description
1	1	913-0023	DEFLECTOR
2	1	913-0215	CHIPPER BASIC MACHINE
3	1	030-0231	18HP BRIGGS & STRATTON ENGINE
4	1	913-0099	FRAME WELDMENT
5	1	913-0106	TOW BEAM
6	1	913-0029	STAND - <b>OPTIONAL</b>
7	1	913-0101	AXLE WELDMENT
8	2	030-0284	4.80 X 8" TIRE
9	1	913-0201	BATTERY BOX
10	1	913-0086	BATTERY
11	1	913-0202	BATTERY HOLD DOWN
12	1	030-0211	PULLEY
13	1	030-0237	BUSHING
14	1	911-0249	SPACER
15	1	704-0106	WASHER
16	1	911-0236	CLUTCH
17	2	030-0193	5H680 BELT
18	1	913-0056	BELT GUARD MOUNTING BRACKET
19	1	911-0240	INNER BELT GUARD
20	1	913-0058	BELT GUARD MOUNTING BRACKET
21	1	911-0214	BELT GUARD MOUNTING BRACKET
22	1	911-0248	BELT GUARD
23	2	703-0424	¼ X ¼ X 2 KEY
24	3	090-0438	5/16-18 J-NUT
25	1	500-0039	HAIR PIN
26	1	030-0232	GAS TANK
27	1	913-0053	GAS TANK MOUNTING BRACKET
28	1	913-0054	BELT TIGHTENER
29	1	030-0239	HOSE AND CLAMP ASSEMBLY
30	2	807-0059	AXLE LOCKING COLLAR
31	1	090-0422	3/8-24 X 1 ½" WHIZ BOLT
32	4	090-0091	5/16-18 X 1 ¾" HHCS
33	19	090-0233	5/16 USS FLATWASHER
34	27	090-0460	5/16-18 NYLOCK NUT
35	14	090-0088	5/16-18 X 1" HHCS
36	1	090-0611	1/4-20 X 2" U-BOLT
37	1	913-0008	HITCH PLATE
38	3	090-0394	5/16 SPLIT LOCKWASHER
39	4	090-0162	10-32 X 3/8 SELF TAPPING SCREW

# CHECK OIL LEVEL BEFORE STARTING CHIPPER

# PARTS BREAKDOWN - C18NH-CHP CHIPPER

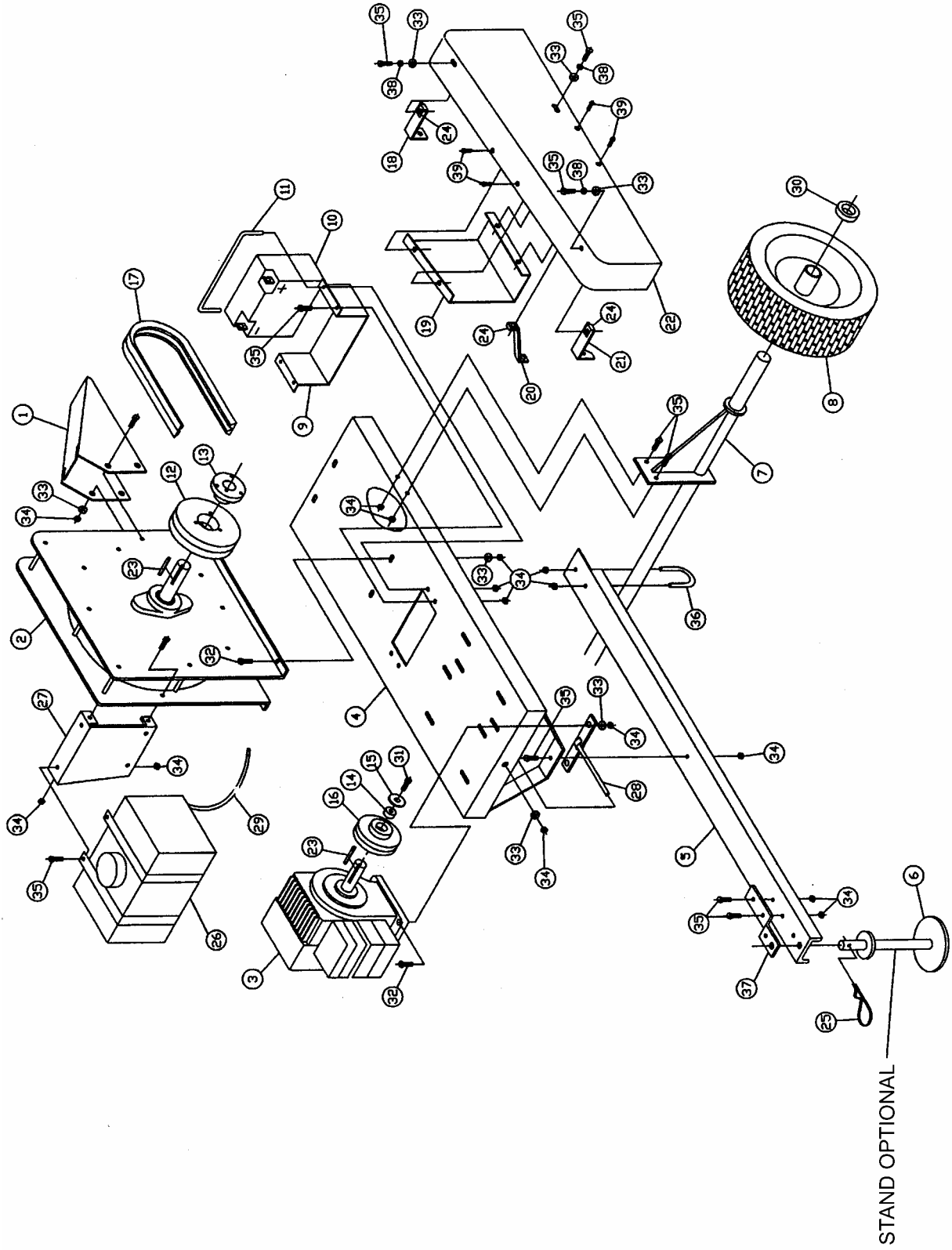



## PARTS LIST – 913-0215 CHIPPER BASIC MACHINE

Item No.	Qty.	Part No.	Description
1	1	913-0034	DRIVE SIDE PLATE WELDMENT
2	9	090-0048	5/16-18 GRIPCO NUT
3	1	911-0163	CHIPPER DISC WELDMENT
4	1	030-0118	FLYWHEEL TAPERLOCK
5	1	500-0031	¼ X ¼ X 1" KEY
6	1	913-0022	FLYWHEEL SHAFT
7	1	913-0042	SCROLL WELDMENT
8	2	911-0010	KNIFE
9	6	090-0642	5/16-18 X 1 ½" SOCKET HEAD CAP SCREW
10	2	913-0021	SCROLL TUBE
11	3	090-0257	¼-20 X 1" SOCKET FLAT HEAD SCREW
12	1	911-0055	WEAR PLATE
13	10	090-0460	5/16-18 NYLOCK NUT
14	8	090-0233	5/16 USS FLATWASHER
15	1	911-0164	CHIPPER HOPPER
16	4	090-0462	5/16-18 X ¾' CARRIAGE BOLT
17	9	090-0077	5/16-18 X 4" HHCS
18	3	090-0245	¼ SAE FLATWASHER
19	4	090-0111	3/8-16 X 1 ¼" HHCS
20	3	090-0470	¼-20 NYLOCK NUT
21	4	090-0042	3/8-16 GRIPCO NUT
22	2	030-0115	SHAFT BEARING
23	8	090-0162	10-32 X 3/8 SELF TAPPING SCREW
24	1	913-0035	CHIPPER SIDE PLATE WELDMENT
25	2	090-0024	SHIM
26	2	030-0117	RETAINING RING
27	2	913-0210	ACCESS COVER

**CHECK OIL LEVEL  
BEFORE STARTING CHIPPER**

# PARTS BREAKDOWN – 913-0215 CHIPPER BASIC MACHINE

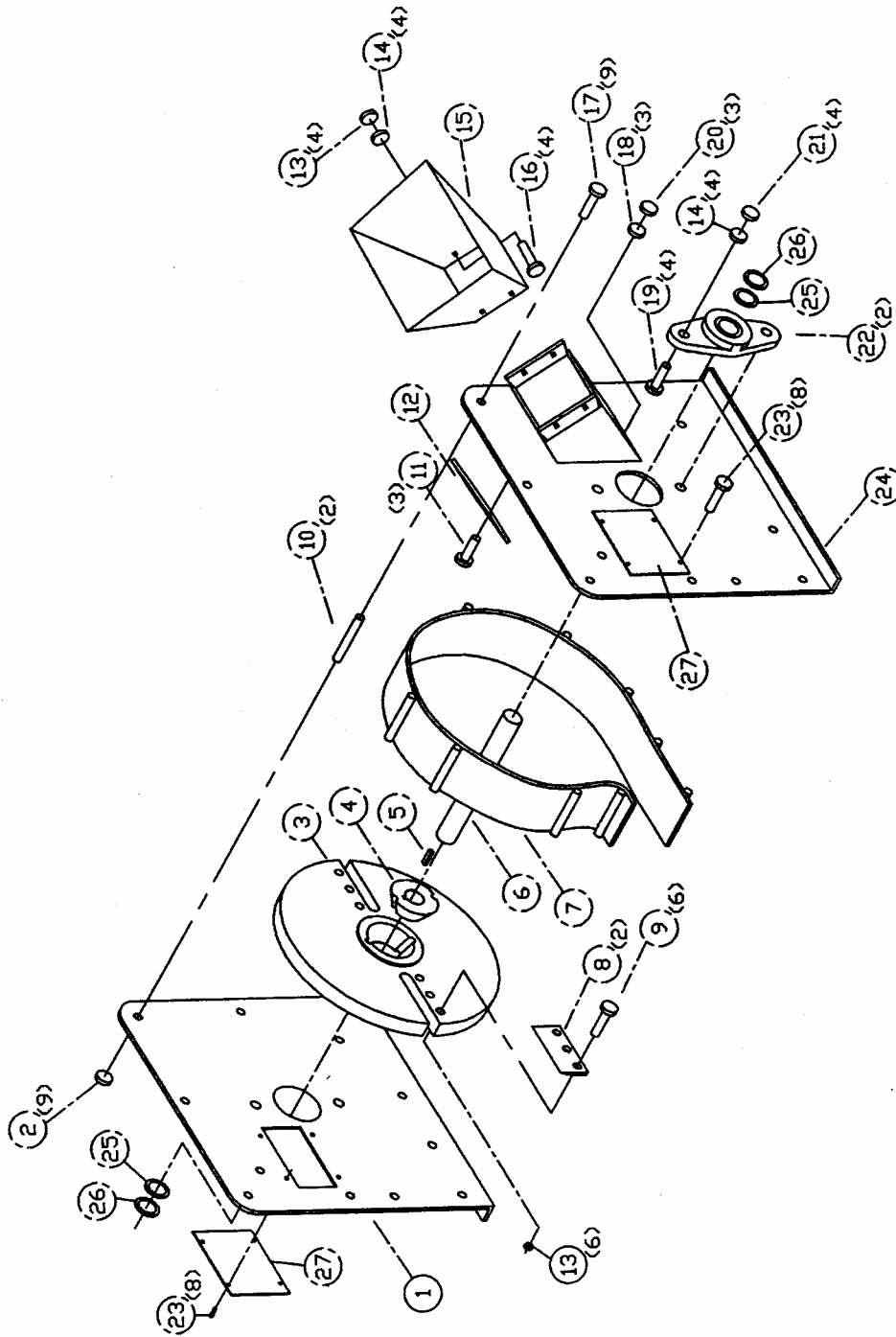

**ROTATING CUTTING BLADES - KEEP HANDS AND FEET OUT OF DISCHARGE AND INLET OPENING WHILE MACHINE IS RUNNING.**

Part No. 091-0055

Part No. 080-0967

**CAUTION**

1. ROTATING CUTTING BLADES - KEEP HANDS OUT OF INLET OPENING WHILE MACHINE IS RUNNING.
2. READ INSTRUCTIONS THOROUGHLY BEFORE OPERATING THE MACHINE.
3. NEVER OPERATE THE CHIPPER WITHOUT THE FEED CHUTE SECURELY IN PLACE.
4. USE GLOVES AND APPROVED SAFETY GLASSES WHEN OPERATING.
5. DO NOT INSERT HANDS OR METAL OBJECTS INTO THE FEED HOPPER OR DISCHARGE CHUTE WHEN THE MACHINE IS RUNNING. IF JAMMED TURN ENGINE OFF AND REMOVE SPARK PLUG WIRE BEFORE CLEARING THE OBSTRUCTION.
6. DO NOT ALLOW BYSTANDERS, ESPECIALLY CHILDREN, NEAR THE MACHINE.
7. KEEP HANDS, FACE AND LOOSE CLOTHING AWAY FROM MOVING PARTS.

**CAUTION**  
**DO NOT REMOVE PROTECTIVE COVER WHILE MACHINE IS RUNNING. SEVERE INJURY WILL RESULT.**

091-0059



Part No. 091-0057

**CAUTION -  
SHUT DOWN ENGINE  
REMOVE SPARK PLUG WIRE  
BEFORE OPENING.**

Part No. 080-0970

**COUNTRY HOME PRODUCTS**  
**Meigs Road, P.O. Box 25, Vergennes, Vermont 05491**

**1(800)DR-OWNER(376-9637)**