

DR® TOW-BEHIND ROTOTILLER

SAFETY & OPERATING INSTRUCTIONS



Model:
PRO 36T

Serial No. _____

Order No. _____

DR® Power Equipment
Toll-free phone: 1-800-DR-OWNER (376-9637)
Web site: www.DRPower.com

WARNING

Read and understand this manual and all instructions before operating this DR TOW-BEHIND ROTOTILLER.

Table of Contents

Chapter 1: General Safety Rules.....	2
Chapter 2: Setting Up Your DR TOW-BEHIND ROTOTILLER	8
Chapter 3: Operating Your DR TOW-BEHIND ROTOTILLER	13
Chapter 4: Maintaining The DR TOW-BEHIND ROTOTILLER.....	18
Chapter 5: Troubleshooting	23
Chapter 6: Parts Lists, Schematic Diagrams And Warranty	25

Conventions used in this manual

⚠ WARNING

This indicates a hazardous situation, which, if not avoided, **could** result in death or serious injury.

⚠ CAUTION

This indicates a hazardous situation, which, if not avoided, **could** result in minor or moderate injury.

NOTICE

This information is important in the proper use of your machine. Failure to follow this instruction could result in damage to your machine or property.

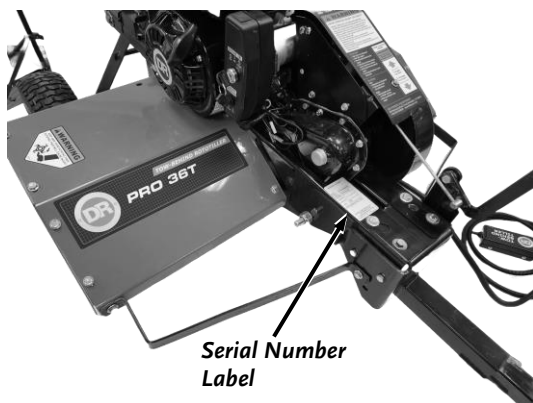

Figure 1

Serial Number and Order Number

A Serial Number is used to identify your machine. The number is located on the serial number label on your machine (**Figure 1**). For your convenience and ready reference, enter the Identification number in the space provided on the front cover of this manual. An Order Number is used to check and maintain your order history. The number is located on the upper left portion of your packing slip. For your convenience and ready reference, enter the order number in the space provided on the front cover of this manual.

Additional Information and Potential Changes

DR Power Equipment reserves the right to discontinue, change, and improve its products at any time without notice or obligation to the purchaser. The descriptions and specifications contained in this manual were in effect at printing. Equipment described within this manual may be optional. Some illustrations may not be applicable to your machine.

California Proposition 65

⚠ WARNING
CANCER AND REPRODUCTIVE HARM - www.P65Warnings.ca.gov.

Chapter 1: General Safety Rules

WARNING

Read this safety & operating Instructions manual before you use the DR TOW-BEHIND ROTOTILLER. Become familiar with the operation and service recommendations to ensure the best performance from your machine. If you have any questions or need assistance, please contact us at www.DRpower.com or call toll-free 1-800-DR-OWNER (376-9637) and one of our Technical Support Representatives will be happy to help you.

Labels

Your DR TOW-BEHIND ROTOTILLER carries prominent labels as reminders for its proper and safe use. Shown below are copies of the safety and information labels that appear on the equipment. Take a moment to study them and make a note of their location on your DR TOW-BEHIND ROTOTILLER as you assemble and before you operate the machine. Replace damaged or missing safety and information labels immediately.



DR® TOW-BEHIND TILLER

WARNING

AVOID SERIOUS INJURY OR DEATH

- RAISE TINES OUT OF GROUND BEFORE STARTING ENGINE OR ENGAGING CLUTCH
- READ AND FOLLOW DIRECTIONS IN OWNER'S MANUAL
- DISENGAGE TINE CLUTCH LEVER BEFORE STARTING
- KEEP ALL SAFETY FEATURES IN PLACE AND OPERATING
- AVOID CONTACT WITH MOVING PARTS. KEEP HANDS AND FEET AWAY FROM TINES
- STOP ENGINE BEFORE FUELING, ADJUSTING OR INSPECTING. DO NOT ADD FUEL TO AN ENGINE THAT IS RUNNING OR HOT
- KEEP BYSTANDERS 25 FT AWAY FROM MACHINE
- NEVER ALLOW CHILDREN OR UNINSTRUCTED ADULTS TO OPERATE MACHINE

TO START

- Raise tines out of ground
- Start tiller engine
- Move throttle control to full speed
- Push back on the tine clutch lever to start tines rotation
- Select lowest tractor ground speed
- Set tractor throttle at or just above idle

TO STOP

Tines

- Raise tines out of ground
- Pull forward on the tine clutch lever

Engine

- Move throttle control to "STOP" position
- Never use choke to stop engine

TINE CLUTCH LEVER

WARNING

RAISE TINES OUT OF GROUND BEFORE ENGAGING CLUTCH

ENGAGED
To engage, Push Back.

To disengage, Pull Forward.
DISENGAGED

DR POWER EQUIPMENT
800 Hinesburg Road, South Burlington, VT 05403
1-800-DR-OWNER www.DRpower.com

#A0001497252

WARNING

TO AVOID SERIOUS INJURY, DO NOT OPERATE WITHOUT BELT GUARD AND ALL OTHER SHIELDS IN PLACE AND IN GOOD CONDITION

224511C

#224511

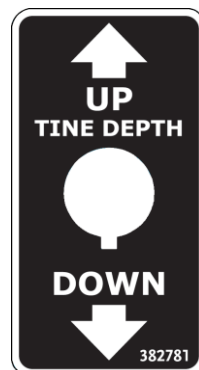

#382781



#224521

WARNING

AVOID SERIOUS INJURY OR DEATH

- Secure control box to your vehicle and the control cable to the tow bar.
- Do not hold the control box in your hands.
- Do not sit on the control cable.
- Do not wrap the control cable around any part of your body.

257261B

#257261

Protecting Yourself and Those Around You

WARNING

The DR TOW-BEHIND ROTOTILLER is a high-powered machine with fast moving parts operating at high speeds. You must operate this machine safely. Unsafe operation can create hazards for you, as well as anyone else in the work area. Use proper clothing and safety gear when operating this machine to prevent or minimize the risk of severe injury. Always take the following precautions when operating the DR TOW-BEHIND ROTOTILLER:

- Always wear protective goggles or safety glasses with side shields to protect your eyes from possible objects thrown from the machine.
- We recommend wearing safety shoes when using this machine. Wear shoes with non-slip treads to improve footing on slippery surfaces. Do not use the machine wearing open sandals or while barefoot.
- Do not wear loose clothing or jewelry, which can catch on the machine's moving parts.
- We recommend wearing long pants and gloves while using this machine. Be sure the gloves fit properly and do not have loose cuffs or drawstrings.
- We recommend the use of ear protectors or ear plugs rated for at least 20 dba to protect your hearing.
- Allow only responsible individuals who are familiar with these general safety rules and operating instructions to use your DR TOW-BEHIND ROTOTILLER. Never allow people who are unfamiliar with these rules and instructions to use your machine.
- Have a complete working knowledge of your tow vehicle and know how to handle it with the DR TOW-BEHIND ROTOTILLER attached.
- Never place your hands, feet, or any part of your body near or under any moving part while the DR TOW-BEHIND ROTOTILLER engine is running.
- Never hold the control box or wrap it around any part of your body. Secure the control box to your tow vehicle with the hook and loop strap provided or with a similar device.
- Keep bystanders away from your work area at all times. To be safe, do not operate the DR TOW-BEHIND ROTOTILLER near children or pets, and never allow children to operate the machine. Stop the tow vehicle and the DR TOW-BEHIND ROTOTILLER engine when another person or pet approaches.
- Do not touch the muffler and engine when the machine is in use as they become very hot and can cause severe burns.
- Clear the work area of objects that might jam or wrap around the tines such as glass, large sticks, stones, metal objects, wire, rope, and string-like materials. Use on these objects could damage the DR TOW-BEHIND ROTOTILLER and/or cause injury.
- Do not use this machine around large roots and surface rocks that you cannot remove.
- Do not use this machine around underground pipes and wiring.
- Never engage the tines when they are in the ground. If the DR TOW-BEHIND ROTOTILLER engine should stall, raise the tines out of the soil and disengage them.
- Never, under any conditions, remove, bend, cut, fit, weld, or otherwise alter standard parts on the DR TOW-BEHIND ROTOTILLER. This includes all shields and guards. Modifications to your machine could cause personal injuries and property damage and will void your warranty.

Slope Operation

WARNING

Use of machinery on slopes is a major factor related to accidents, which can result in severe personal injury. Use of machinery on slopes requires caution. If you feel uneasy using the DR TOW-BEHIND ROTOTILLER on a slope, do not operate it. Always take the following precautions when using this machine on slopes:

Always:

- Exercise extreme caution when changing direction on slopes.
- Watch for holes, ruts, and bumps on the ground.

 WARNING**Never:**

- Never operate near drop-offs, ditches, or embankments; you could lose control of your tow vehicle and/or the DR ROTO-HOG power tiller.
 - Never operate on slopes greater than 5 degrees, or on any excessively steep slope.
 - Never operate on wet, or slippery slopes. Reduced traction could result in tipping over your tow vehicle and/or the DR ROTO-HOG power tiller.
 - Never park the tow vehicle on a steep grade or slope.
-

Safety for Children

 WARNING

Tragic accidents can occur if the operator is not alert to the presence of children. Children can be attracted to the DR TOW-BEHIND ROTOTILLER and its tilling activity. Never assume that children will remain where you last saw them.

- Keep children out of the work area and under the watchful care of a responsible adult.
 - Be alert and always turn off your tow vehicle and the DR TOW-BEHIND ROTOTILLER engine if children enter the work area.
 - Before, and while moving your tow vehicle backwards, look behind, and down for small children.
 - Never allow children to operate the DR TOW-BEHIND ROTOTILLER.
 - Use extra care when approaching blind corners, shrubs, trees, or other objects that may obscure your vision.
-

Safety with Gasoline-Powered Machines

 WARNING

Gasoline is a highly flammable liquid. Gasoline also gives off flammable vapor that can be easily ignited and cause a fire or explosion. Never overlook the hazards of gasoline and always follow these precautions:

- Never run the DR TOW-BEHIND ROTOTILLER engine in an enclosed area or without proper ventilation as the exhaust from the engine contains carbon monoxide, which is an odorless, tasteless, and deadly poisonous gas.
 - Store all fuel and oil in containers specifically designed and approved for this purpose and keep away from heat, open flame, and out of the reach of children.
 - Fill the gasoline tank outdoors with the engine off and allow the engine to cool completely. Do not handle gasoline if you or anyone nearby is smoking, or if you are near anything that could cause it to ignite or explode. Replace the fuel tank and fuel container caps securely.
 - If you spill gasoline, do not attempt to start the engine. Move the machine away from the area of the spill and avoid creating any source of ignition until the gas vapors have dissipated. Wipe up any spilled fuel to prevent a fire hazard and properly dispose of the waste.
 - Allow the DR TOW-BEHIND ROTOTILLER engine to cool completely before storing in any enclosure. Never store the machine with gas in the tank or with gas in a fuel container near an open flame or spark such as a water heater.
 - Never make adjustments or repairs with the engine running. Before making an adjustment or repair, shut off the DR TOW-BEHIND ROTOTILLER engine, wait five (5) minutes to cool, then disconnect the spark plug wire and keep the wire away from the spark plug to prevent accidental starting.
 - Never check for an ignition spark with the spark plug or spark plug wire removed. Always use an approved spark tester.
 - Never tamper with safety devices. Regularly check their proper operation.
 - Never change the engine governor settings or modify the engine speed. Modifications will void your warranty.
 - To reduce fire hazard, keep the engine and muffler area free of debris build-up such as leaves, grass, oil, grease, or any other combustible material. Clean the engine area after each use.
 - Never operate the engine without the muffler. Inspect the muffler periodically and replace if necessary. If the engine is equipped with a muffler deflector, inspect it periodically and replace if necessary.
-

WARNING

- Never operate the engine with the air cleaner or cover over the carburetor air intake removed, except for adjustment. Removal of such parts could create a fire hazard. Do not use flammable solutions to clean the air filter.
 - Always check fuel lines and fittings frequently for cracks or leaks, replace if necessary.
 - Replace rubber fuel lines and grommets when worn or damaged, but do not use over five (5) years.
-

General Safety

WARNING

Safe operation of the DR TOW-BEHIND ROTOTILLER is necessary to prevent or minimize the risk of ***death or serious injury***.

Unsafe operation can create a number of hazards for you. Always take the following precautions when operating this machine:

- The DR TOW-BEHIND ROTOTILLER is a powerful tool and not a plaything. When using this machine, exercise extreme caution at all times. The design of this machine is to till soil. Do not use it for any other purpose.
 - The operator or user of the DR TOW-BEHIND ROTOTILLER is responsible for accidents or hazards occurring to other people, their property, and themselves.
 - Know how to quickly stop the DR TOW-BEHIND ROTOTILLER. See page 13.
 - Never allow people or pets to ride on this machine.
 - If the machine should make an unusual noise or vibration, shut off the tow vehicle and the DR TOW-BEHIND ROTOTILLER engines. Vibration is generally a warning of trouble. Wait five (5) minutes for the DR TOW-BEHIND ROTOTILLER engine to cool. Disconnect the spark plug wire and then inspect the machine for clogging, damaged tines, or loose engine mounting bolts. Clear any obstructions and repair and/or replace damaged parts.
 - Always keep the machine in good safe operating condition. Always make certain nuts and bolts are tight and always use the supplied self-locking hardware. Do not use substitute hardware.
 - Always shut off the tow vehicle and DR TOW-BEHIND ROTOTILLER engine, wait five (5) minutes to cool, and disconnect the spark plug wire before attempting to clear any obstructions.
 - Use the DR TOW-BEHIND ROTOTILLER only in daylight and give complete and undivided attention to the job at hand.
 - Do not hurry or take things for granted when using the DR TOW-BEHIND ROTOTILLER. When in doubt about the machine or your surroundings, stop the machine and take time to look things over.
 - Exercise extreme caution when on or crossing drives, walks, or roads. Stay alert for hidden hazards or traffic.
 - Never leave the DR TOW-BEHIND ROTOTILLER unattended with the engine running. If leaving the machine, shift the tow vehicle into neutral, set the vehicle parking brake, turn off the vehicle engine and remove key; raise the tines of the tiller and disengage the tine drive, turn off the tiller engine and, if electric start, remove the tiller key.
 - Prior to transportation to and from the work area, disengage the tiller tine drive, stop the tiller engine, and raise the tines.
 - Do not operate the machine when under the influence of alcohol, drugs, or medication.
 - See manufacturer's instructions for proper operation and installation of accessories. Only use accessories approved by DR power equipment.
-

A Note to All Users

No list of warnings and cautions can be all-inclusive. If situations occur that are not covered by this manual, the operator must apply common sense and operate the DR TOW-BEHIND ROTOTILLER in a safe manner. Visit our website at www.DRPower.com or call 1-800-DR-OWNER (376-9637) for assistance.

Under California law, and the laws of some other states, you are not permitted to operate an internal combustion Engine using hydrocarbon fuels without an Engine Spark Arrester. This also applies to operation on US Forest Lands. All DR TOW-BEHIND ROTOTILLERS shipped to California and Washington State are provided with spark arresters. Failure of the owner/operator to maintain this equipment in compliance with state regulations is a misdemeanor under California law and may be in violation of other state and/or federal regulations. Contact your local Fire Marshal, Forest Service, State Park Association, or the appropriate state organization for specific information in your area.

Chapter 2: Setting Up Your DR TOW-BEHIND ROTOTILLER

It may be helpful to familiarize yourself with the controls and features on your new machine by reviewing **Figure 2** before beginning the steps outlined in this chapter. For technical assistance, please visit our website at www.DRPower.com.

DR TOW-BEHIND ROTOTILLER and Features

Note: The model shown in Figure 2 may look slightly different from your machine.

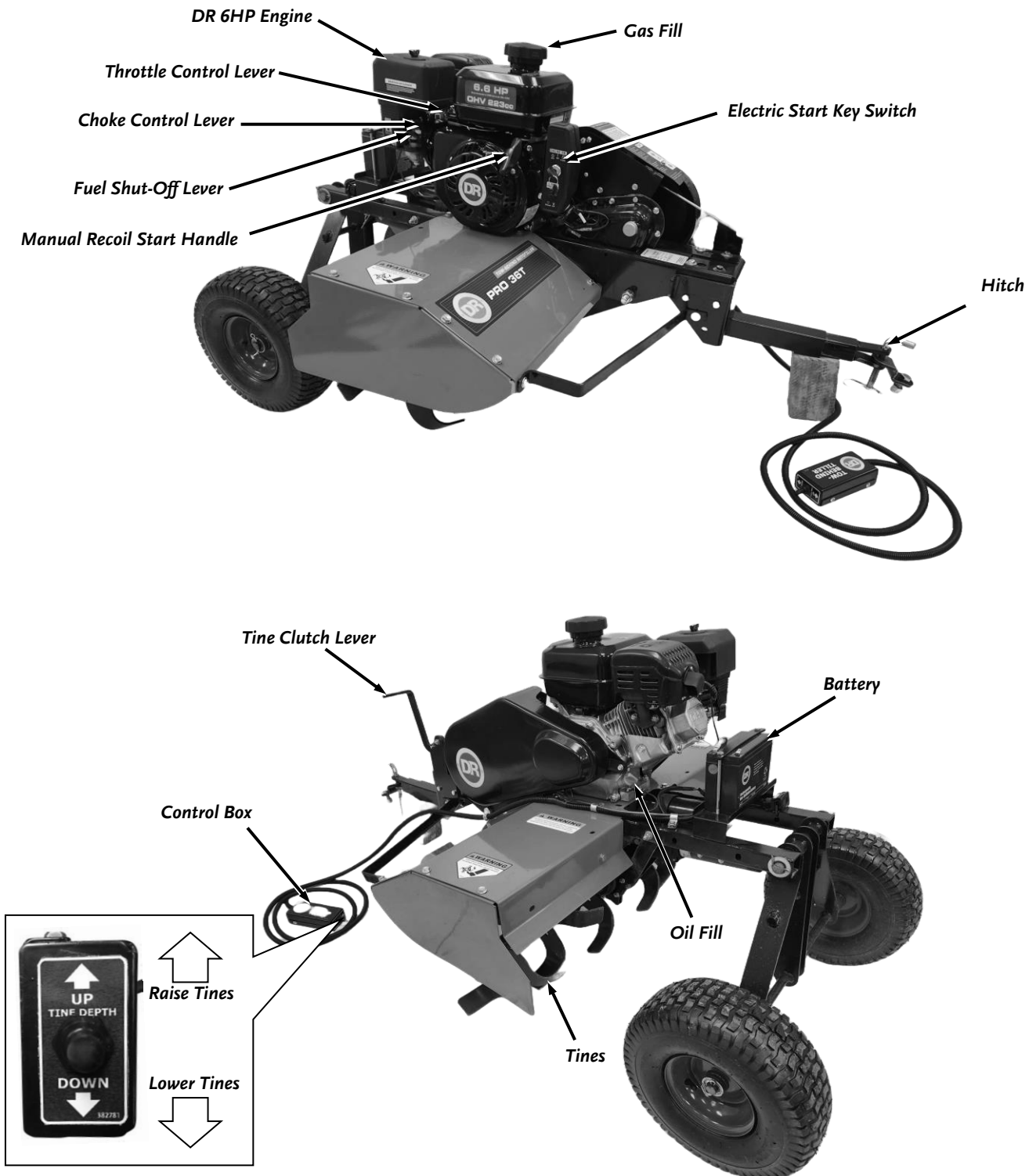

Figure 2

DR TOW-BEHIND ROTOTILLER Specification Sheet

Engine	DR 6.6HP, 223 CC, Single Cylinder
Approximate Run Time on a Tank of Fuel	75 minutes
Battery	12 Volt, 9AH
Towing type	Pin Hitch
Ground Clearance in Transport Mode	2.75"
Height Adjustment	Electric Actuator
Range	7" deep
Actuator Stroke	3.94"
Actuator Maximum Load	250 lbs.
Length of Remote-Control Cable	46"
Tine Size	12"
Number of Tines	24
Wheels	15" x 6.00"-6 NHS (14" x 5.5")
Machine Size	39"w x 66"L (Transport), 35"H x 77"L (Lowest Position)
Machine Weight	217 lbs
Tongue Weight	90 lbs. (Transport) 112 lbs. (Lowest Position)
Shipping Weight	320 lbs. Electric Start
Gauge of Steel on Shroud	14
Gauge of Steel on Frame	10 Gauge, 1.5" Tubular Steel

Assembling the Machine

Note: Unpacking and assembling the DR TOW-BEHIND ROTOTILLER is a two-person job, as the Machine weighs 217 pounds. We recommend you have an extra set of hands available before you begin.

Parts Supplied on Shipping Pallet:

- DR TOW-BEHIND ROTOTILLER
- Two Wheels
- Hardware Bag: (Located on the Gas Tank of the unit.)
 - Battery Charger
 - Two Flat Washers, 3/4"
 - Two Cotter Pin, 3/16" x 2"
 - Channel Pin, 1/2"
 - Hair Cotter Pin, 5/32" x 3"
 - *Safety & Operating Instructions* Manual
 - DR Engine User Manual
 - Hook & Loop Strap
 - Hitch Extension Bracket
 - Bolt, 1/2-13 X 1-1/4"
 - Lock Nut, 1/2-13

Tools and Supplies Needed:

- Pliers
- 1/2" Wrench
- Two 9/16" Wrenches
- Grease Gun w/General purpose Grease
- Gloves

CAUTION

- Stabilize the shipping container on a flat surface before attempting to assemble the machine.

1. Cut the Cable Ties that are securing the Wheels to the Pallet using Wire Cutters (**Figure 3**). Remove the Wheels from the Pallet.
2. Use two 9/16" Wrenches to Remove the Bolt and nut that Secures the Tow Hitch to the Pallet.
3. Use a 1/2" Wrench to remove the four Bolts from the Axle Hold-Down Brackets at the rear of the Pallet and remove the Bracket from each Axle.

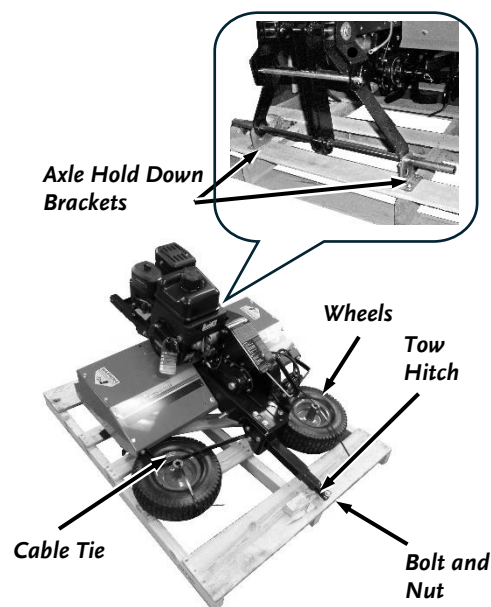

Figure 3

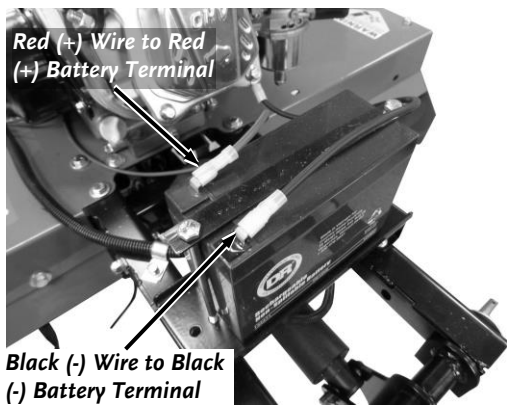

Figure 4

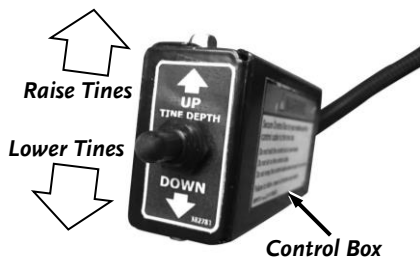

Figure 5

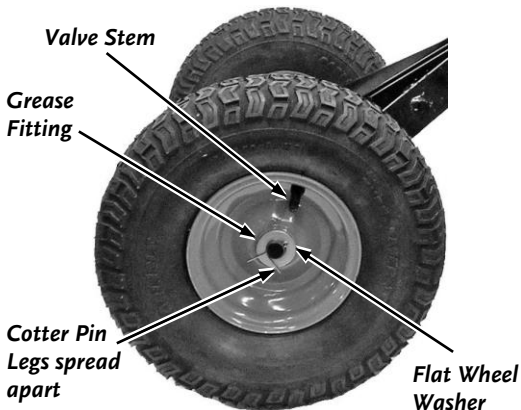

Figure 6

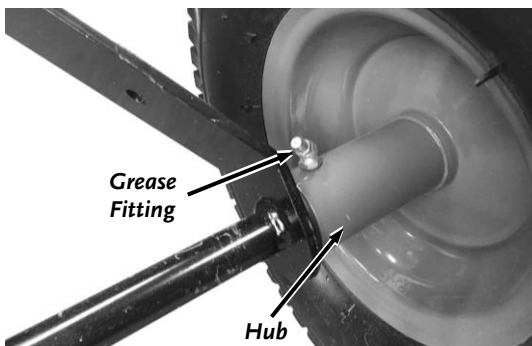

Figure 7

4. Plug the Battery Cables onto the Battery Terminals (**Figure 4**).
5. Using the Control Box, lower the Tines all the way down, which will raise the Wheel Axles from the pallet (**Figure 5**).
6. Slide a Wheel onto each Axle making sure that the Valve Stem is facing the outside (**Figure 6**).
7. From the Hardware Bag, place one 3/4" Flat Washer on each Axle, slide a Cotter Pin through the Hole in the Axle on each side, and spread the Cotter Pin Legs using Pliers.
8. Grease the Fittings on the Wheel Hubs with a Grease Gun only until Grease starts coming out of the Hub (**Figure 7**).
9. Raise the Tines (lowering the Wheels), and with the help of another person, pull the tiller from the shipping pallet. Do not discard your packaging material until you are fully satisfied with your new DR TOW-BEHIND ROTOTILLER.

About the Battery

The DR TOW-BEHIND ROTOTILLER comes with a 12-Volt, maintenance-free, rechargeable, sealed lead acid Battery. A fully charged Battery runs about 20 hours or 400 up/down cycles. Properly maintained and charged, the Battery provides years of dependable service.

! WARNING

Electrical hazard: prevent fire

- Never modify the DR TOW-BEHIND ROTOTILLER's electrical system. Modifications could ruin the electrical system as well as cause a fire, resulting in serious injury.
- Using electrical components other than those supplied with your machine could cause the electrical system to overheat, explode, or start a fire.
- Using the wrong type of Battery or charger could cause a fire or explosion, resulting in serious injury.
- Use the 12-volt charger supplied with your machine or a 12-volt, 2 amp max, substitute charger to charge the Battery.
- Use the charger only in dry locations. Avoid contact with water.
- Only adults should handle the Battery. It contains sulfuric acid (an electrolyte) and the Battery is heavy; dropping it could result in serious injury.
- Never allow children to charge the Battery. The electricity involved in charging the Battery could cause severe injury.
- Examine the charger, its connectors, and the Battery for excessive wear or damage each time you charge the Battery. If you see any excessive wear or damage, do not use the charger or the Battery, replace them.
- Never lift or carry the Battery by the cables or terminals. This can damage the Battery and possibly start a fire, resulting in serious injury. Lift and carry the Battery only by its case.
- Do not short circuit the Battery.

Charging the Battery

Charging the Battery is a simple process. Leave the Battery in your DR TOW-BEHIND ROTOTILLER when you charge it.

1. Attach the Black (-) Wire Terminal from the Charger to the Black (-) terminal of the Battery, then attach the Red (+) Wire Terminal to the Red (+) Battery terminal.
2. Plug the Charger into a standard wall outlet.
 - Typically, the Battery takes between 6 and 8 hours to fully charge. The Battery does not have a “memory”; so don’t worry about overcharging the Battery or charging it too often.
 - You can charge the Battery many times. The Battery lasts longer if you charge it before it is fully drained. Keep it fully charged and at room temperature when not using your DR TOW-BEHIND ROTOTILLER.
 - Once the Battery is charged, pull the plug from the wall outlet and then remove the Charger from your Battery. However, you can leave your Battery plugged in and charging for an extended period.
 - Store the Charger in its self-locking plastic shipping bag. Keep the Charger in a dry location.
 - If the Battery does not hold its charge for very long under normal conditions or it simply won’t hold a charge, then replace it. You can purchase replacement Batteries directly from us. To install your new Battery, detach the cables, remove the Battery Clamp, and remove the dead Battery. Next, install the new Battery, replace the Battery Clamp, and attach the cables.

NOTICE

When the battery gets old and no longer accepts a charge, remove it from your DR TOW-BEHIND ROTOTILLER. Never leave a dead battery in your machine.

Adding the Engine Oil and Gasoline

Capacities	
DR 6.6HP, 223 CC, Single Cylinder	⇒ SAE 30 High Detergent Oil – 17 oz. (.5L)
Gasoline Tank	⇒ Unleaded Gas (85 Octane minimum), 3.5 Qts. (3.4 L)

Note: Use SAE 30 High Detergent oil classified “For Service SF, SG, SH, SJ” or higher. Do not use special additives. Other types of oil could cause problems operating your machine. Please refer to your Engine Owner’s Manual for detailed oil information.

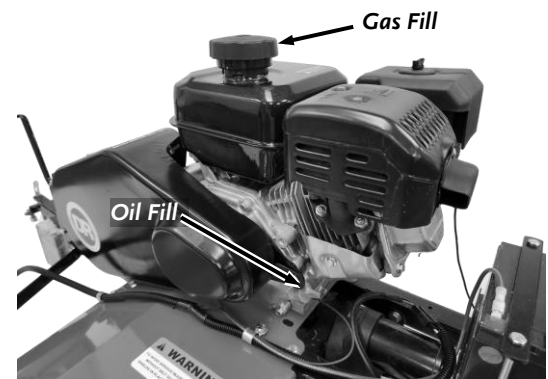

Figure 8

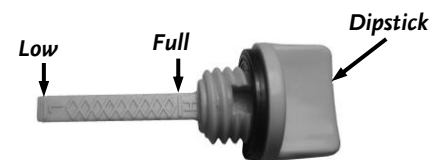

Figure 9

NOTICE

- You must add oil before starting the engine. This machine is shipped without oil. Traces of oil may be in the reservoir from factory testing, but you must add oil before starting the engine. Fill the reservoir slowly, checking the level frequently, to avoid overfilling.
- To get an accurate reading when checking the oil level:
 - The machine should be on a level surface.
 - The Dipstick should be screwed all the way in to ensure an accurate fluid level reading.

1. Place the machine on a level surface and remove the Oil Fill/Dipstick (**Figure 8**).
2. Initially add 12 oz. (1/3 quart) of SAE 30 High Detergent oil, recommended by the Engine Manufacturer, and wait one minute for the oil to settle.
3. Continue adding a few ounces of oil at a time, until the oil reaches the Full line on the Dipstick (**Figure 9**). Be careful not to overfill.

4. Fill the Gas Tank with fresh, unleaded gas (with a minimum of 85 Octane), to approximately 1" to 1-1/2" below the top of the Fill Neck to allow for Fuel expansion. Be careful not to overfill and reinstall the Cap before starting the Engine. See your Engine Owner's Manual for more information.

Note: To refill the Gas Tank, turn the Engine OFF, and let the Engine cool at least five minutes before removing the Gas Fill Cap.

! WARNING

Fill the gas tank outdoors or in a well-ventilated area, away from sparks, open flames, pilot lights, heat, and other ignition sources.

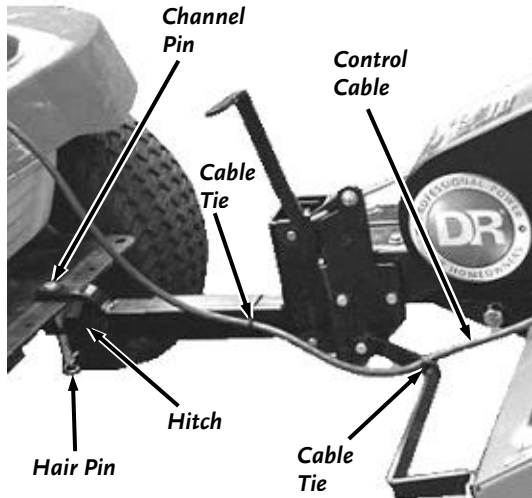

Figure 10

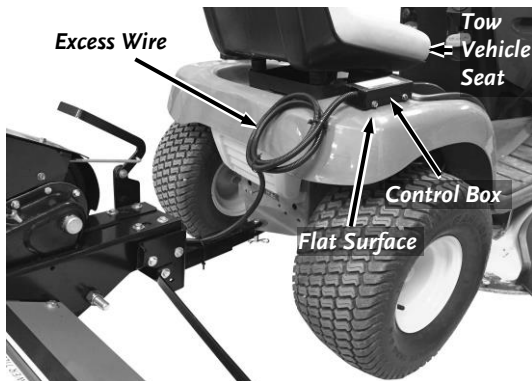

Figure 11

Connecting the DR TOW-BEHIND ROTOTILLER to your Tow Vehicle

1. Back up your Tow Vehicle so that the Hitch of the Vehicle is in line with and next to the Hitch on the DR® TOW-BEHIND ROTOTILLER. Set the Parking Brake on the Tow Vehicle.
2. Remove the Hair Pin and Channel Pin from the Hitch on the DR TOW-BEHIND ROTOTILLER (**Figure 10**). Position the Hitch onto the Tow Vehicle and reinstall the Channel Pin and Hair Pin.

Note: The DR TOW-BEHIND ROTOTILLER comes with a Hitch Extension Bracket. This Bracket can be used to slightly lower or elevate the front of the machine. When using this bracket, use the provided 1/2-13 x 1-1/4" Bolt and 1/2-13 Locknut to attach the Bracket to the Tow Vehicle and use the Channel Pin and Hair Pin to attach the Machine to the Bracket.

3. Remove any slack coming from the Tiller as you secure the Control Cable to the Tiller Frame and Tow Bar with Cable Ties.

Attaching the DR TOW-BEHIND ROTOTILLER Control Box

NOTICE

Be sure to route the Remote-Control Cable away from the muffler of the tow vehicle to prevent damage to the Cable.

1. Position the Control Box on your Tow Vehicle within reach of the seated Tow Vehicle driver (**Figure 11**).
2. Secure the Control Box on a clean flat surface with the Warning Label facing up using the self-adhesive Hook and Loop strips provided with the DR TOW-BEHIND ROTOTILLER.

Note: To prevent the Control Cable from entering the Tines during operation, coil up any excess Cable on the Tow Vehicle and secure with a Cable Tie. Make sure you leave enough Cable length to accommodate turns.

! WARNING

Do not hold the Control Box by putting the cord under your leg or any other part of your body. Secure the Control Box to the tow vehicle only. If the cord gets caught in the tines, the Control Box may be yanked from its secured position. Be sure you are not in its path.

Chapter 3: Operating Your DR TOW-BEHIND ROTOTILLER

This chapter covers the procedures for starting and stopping your new DR TOW-BEHIND ROTOTILLER and discusses basic operation features. You may find it helpful to review the DR TOW-BEHIND ROTOTILLER Controls and Features on page 8 before reading this chapter.

⚠ WARNING

- The design of this machine is for tilling soil. Never use this machine for any other purpose as it could cause serious injury.
- Contact with internal rotating parts will cause serious personal injury. Never put hands, face, feet, or clothing under or near the debris shield with the engine running.
- Before performing any maintenance procedure or inspection, stop the engine and wait five minutes to allow all parts to stop and cool. Disconnect the spark plug wire keeping it away from the spark plug.
- Inspect the area where you will be working. The site must be free of potentially hazardous obstacles such as glass, large stones, sticks, wire, rope, and string-like materials. Make sure there are no people or animals in the area around the DR ROTO-HOG power tiller.

Operating Parameters



The DR TOW-BEHIND ROTOTILLER is designed to be used with most ATVs, Lawn\Garden Tractors, and Compact Tractors. The DR TOW-BEHIND ROTOTILLER should never be used with a Truck (2WD or 4WD). Use of a Truck will void the DR TOW-BEHIND ROTOTILLER Warranty.

Before Starting the Engine

1. Raise the Tines and place the machine on level ground.
2. Check the Engine oil level every time you use the machine.
3. Check the gasoline level.
4. Remove any built-up debris from the Tines.
5. Pull the Tine Clutch Lever all the way forward until it locks into place to disengage the Tines. (**Figure 12**) A Safety Interlock Switch prevents the Engine from starting with the Tines engaged.
6. Move the Fuel Shut-Off Lever to the right "ON" position (**Figure 13**).

Manual Starting

Note: You may use this starting method even though the DR TOW-BEHIND ROTOTILLER may be equipped with Electric Starting; however, make sure the Key is in the RUN position.

1. Turn the Key to the RUN  position.
2. When starting a cold Engine, push the Choke Control Lever to the left so it is in the CHOKE  position and the push the Throttle Control Lever to the left so it is in the RUN  position (**Figure 13**).
3. Grasp the Recoil Starter Handle and **slowly pull until you feel resistance**, then pull the cord with a **smooth accelerating motion** to start the Engine. Do not let the Starter Handle snap back against the Engine. One or two pulls usually starts the DR TOW-BEHIND ROTOTILLER.
4. After the Engine starts, adjust the Choke Lever until the engine runs smoother. Continue this process until the engine runs well with the Choke fully in the RUN position.

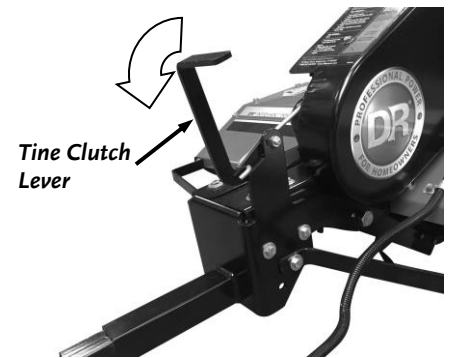

Figure 12

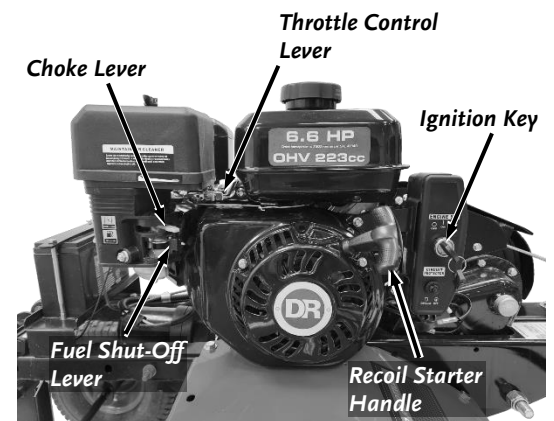

Figure 13

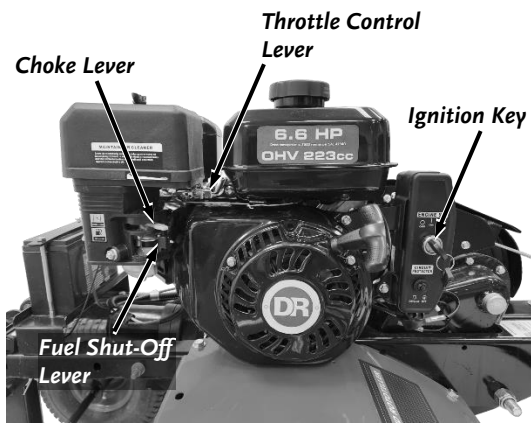

Figure 14

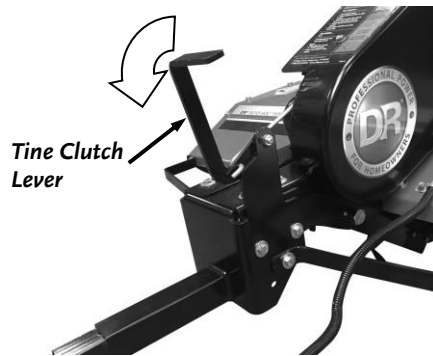







Figure 15

Electric Starting

1. When starting a cold Engine, push the Choke Control Lever all to the left so it is in the CHOKE  position and the push the Throttle Control Lever to the left so it is in the RUN  position (Figure 14).
2. Turn the Key to the Start  position until the Engine starts, then release. The Key will snap back to the RUN  position and the Engine will continue to run.
3. After the Engine starts, adjust the Choke Lever until the engine runs smoother. Continue this process until the engine runs well with the Choke fully in the RUN position.

Stopping the Engine

1. Raise the Tines out of the Ground.
2. Pull the Tine Clutch Lever all the way forward until it locks into place to disengage the Tines (Figure 15).
3. Move the Throttle Control Lever to the Right so it is in the Idle  position and turn the Key to STOP .

NOTICE

Never stop the engine by moving the throttle control lever to the choke position. This could cause an engine backfire resulting in engine damage.

Operating Safety

! WARNING

- Be thoroughly familiar with the controls and the proper use of your DR TOW-BEHIND ROTOTILLER before using. Never allow anyone to operate the DR TOW-BEHIND ROTOTILLER without first reading and understanding all instructions in this manual.
- Engage the tines in the air without contacting the soil. Slowly lower the tines into the soil while seated on the tow vehicle. Engaging the tines with them in the soil may cause the Roto Hog to push the tow vehicle forward.
- The first pass on unknown soil conditions should be only about an inch to test the soil conditions.
- Never allow people or pets to ride on this machine.
- Always check for objects and obstacles in the path of this machine before moving.
- Always wear protective goggles or safety glasses with side shields to protect your eyes from possible objects thrown from this machine.
- Do not wear loose clothing or jewelry, which can catch on the machine's moving parts.
- We recommend wearing long pants and gloves while using this machine. Be sure the gloves fit properly and do not have loose cuffs or drawstrings.
- We recommend wearing safety shoes when using this machine. Wear shoes with non-slip treads to improve footing on slippery surfaces. Do not use the machine wearing open sandals or while barefoot.
- We recommend the use of ear protectors or ear plugs rated for at least 20 dba to protect your hearing.
- Never put your hands near the tines to clear debris while the engine is running. Always shut off the DR TOW-BEHIND ROTOTILLER engine and disconnect the spark plug wire before clearing debris.
- Do not refuel the engine while it is hot or running.

NOTICE

Use common sense when using the machine. Learn to recognize the change in sounds when it is overloaded. Turn off the engine immediately if the machine becomes jammed to prevent damage to the drive system.

Engaging the Tines

- Push the Tine Clutch Lever towards the back of the machine to engage the Tines (**Figure 16**).

Disengaging the Tines

- Pull the Tine Clutch Lever Forwards to disengage the Tines (**Figure 16**).

Using the Control Box

The Control Box contains a 3-position Toggle Switch which is used to raise and lower the Tines on your DR TOW-BEHIND ROTOTILLER.

To Raise the Tines

- Push the Toggle Switch to the Up position and hold. When you release the Switch, it will return to center (OFF) position (**Figure 17**).

To Lower the Tines

- Push the Toggle Switch to the Down position and hold. When you release the Switch, it will return to center (OFF) position (**Figure 17**).

Operating Procedures

There are three applications for the DR TOW-BEHIND ROTOTILLER: Garden Tilling, Sod Busting, and small Food Plot installation. For all applications, engage the tines while they are raised and not contacting the soil. Then slowly lower the tines into the soil to the proper depth for the different soil conditions.

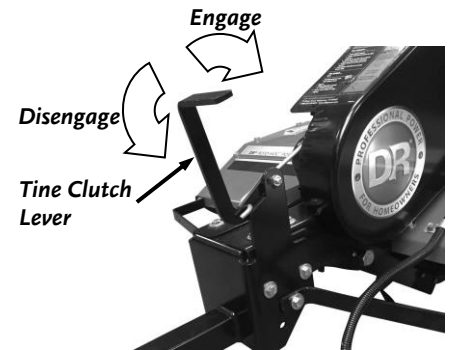

Figure 16

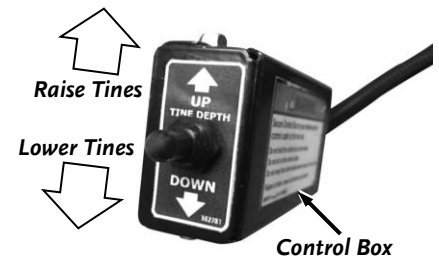

Figure 17

! WARNING

- Do not use this machine around large roots and surface rocks that you cannot remove.
- Never engage the tines when they are in the ground. If the DR TOW-BEHIND ROTOTILLER engine should stall, raise the tines out of the soil and disengage them.
- Engage the tines in the air without contacting the soil. Slowly lower the tines into the soil while seated on the tow vehicle. Engaging the tines with them in the soil may cause the Roto Hog to push the tow vehicle forward.
- The first pass on unknown soil conditions should be only about an inch to test the soil conditions.
- When transitioning from a tilled area to the edge where the sod has not been tilled, be sure to stop the tow vehicle so tiller tines are short of the untilled area, disengage and lift the Tines up before continuing.

Gardens:

1. Check the area for large stones and foreign objects that could snag or wedge into the tines.
2. Perform a soil test to assess needs for soil treatment.

Tip: If a soil test indicates amendments necessary (lime, fertilizers, sulfur, etc) then apply before tilling to best integrate it into the soil. You can apply amendment with the Optional Spreader and incorporate it with the Tiller.

3. Check wetness in the soil to determine if clumping will require slower Tow Vehicle speeds.

Food Plot Installation and Sod Busting:

1. Clear the work area of objects such as glass, large sticks and stones, roots, metal objects, wire, rope, and string-like materials.
2. Cut all vegetation to the lowest possible height.

3. Remove the cut vegetation by either rake, vacuum, blowing OR allow it to dry several days and re-cut.

CAUTION

Failure to remove long vegetation will result in frequent stalling of the engine due to entanglement of tines.

Note: For information on ordering the optional equipment, visit our web site at www.DRpower.com.

4. Refer to seed specifications to determine the optimal depth of tillage necessary.
5. With the initial pass, begin breaking only the top inch of soil to breakup sod.
6. Break the soil thoroughly across the entire area. See the following "Tilling Tips".
7. Gradually lower the Tines 1-2 inches and repeat step 6 until you are satisfied with the tillage created.
8. Using the Optional Spreader, apply seed at a rate specified by the seed manufacturer.

Tilling Tips

- In compacted soil or sod, or in food plot and sod busting applications, several passes may be necessary to till to a depth of seven (7) inches. For the first pass, just scratch the surface. The depth for each successive pass needs to be determined by individual site and soil conditions. If the machine stalls repeatedly, you should till slower or not as deep.
- Check the ground moisture. DO NOT till if you can make a ball of soil in your hand from the ground to be tilled; it is too wet. Create full tillage (depths up to 7") after entire area is dry.
- To obtain the most efficient tillage, operate the DR TOW-BEHIND ROTOTILLER Engine at full throttle at the slowest speed of your Tow Vehicle.
- When operating the machine for the first time, proceed slowly and carefully until you become familiar with the proper method of operating the machine.
- Soil conditions will determine how deep the machine can penetrate on the first pass.
- In damp soil, till only the top inch of seedbed. Allow tillage to dry for several hours in sunny and/or windy conditions.
- Listen to your DR TOW-BEHIND ROTOTILLER Engine. When the Engine RPM decreases or stalls (overloaded condition) raise the Tines for shallower tilling. If the Engine is lightly loaded, lower the Tines to increase the tilling depth.
- If the soil is extremely hard and dry, it may be desirable to "cross till" an area at a shallow depth first, then till the soil in the direction of planting rows on subsequent passes until the desired tillage is obtained.
- Where possible, we recommend that you till in a pattern similar to that shown in **Figure 18**.

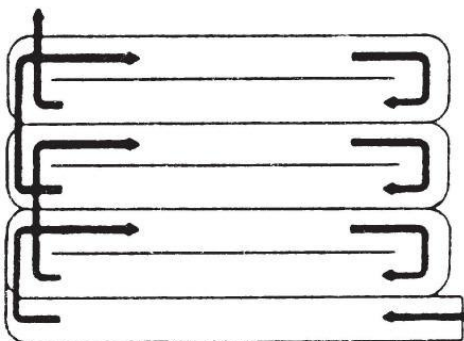

Figure 18

1. Lower the Tines and make the first pass.

Note: If you raise the tines at the end of a pass, use care to lower them back to the same depth. Tilling too deep on the first pass may cause the tow vehicle to surge forward and/or cause the Tiller to stall or break Shear Bolts.

2. Skip a space equal to the width of the machine.
3. Make the return pass.
4. Till the skipped areas.

Cultivating Tips

You can use the DR TOW-BEHIND ROTOTILLER for cultivating (*Figure 19*), which requires a minimum of two inches of soil penetration.

- Set the tines so they will penetrate the soil to a depth of two to three inches.
- Run the DR TOW-BEHIND ROTOTILLER Engine at Full Throttle.

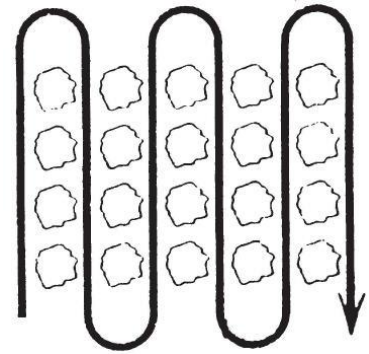

Figure 19

Slopes and Uneven Terrain

⚠ WARNING

- Never operate your DR TOW-BEHIND ROTOTILLER on slopes greater than 5 degrees. Doing so could result in serious injury or damage to your machine.
- When operating the machine over uneven terrain and slopes, use extreme caution to not tip over the machine. Move slowly if the ground has ruts, bumps, and other depressions.

Handling and Transporting

⚠ WARNING

Never lift the machine while the engine is running.

We recommend using two people to lift the DR TOW-BEHIND ROTOTILLER. Lift the machine by the Hitch to connect and disconnect from your Tow Vehicle. To transport the machine with your Tow Vehicle, first raise the tines to the MAX position (lower the Wheels) using the Control Box.

NOTICE

- The DR TOW-BEHIND ROTOTILLER is not equipped for towing on any public roadway.
- When towed, the maximum safe towing speed is 10 mph.

Chapter 4: Maintaining The DR TOW-BEHIND ROTOTILLER

This chapter covers regular maintenance procedures that will ensure the best performance and long life of your DR TOW-BEHIND ROTOTILLER. For Engine maintenance, please refer to the Engine Owner's Manual that came with your machine. Service intervals listed in the checklist below supersede those listed in the Engine Owner's Manual. Maintenance Kits and accessories are available through our website at www.DRPower.com.

WARNING

When performing any maintenance, you must first shut off the engine, wait five minutes to allow parts to cool and disconnect the spark plug wire, keeping it away from the spark plug.

Regular Maintenance Checklist

Note: Consider that the service intervals shown are the maximum under normal operating conditions. Increase frequencies under extremely dirty or dusty conditions.

PROCEDURE	BEFORE EACH USE	EVERY 8-10 HOURS	EVERY 35 HOURS
Check the Engine Oil Level	▲		
Clean the Tines and Debris Shield*	After each use		
Check the general condition of the machine, e.g. nuts, bolts, welds, etc.	▲		
Clean Engine Exterior & Cooling Fins	▲		
Check the Tines Shear Bolts for wear	▲		
Grease the Tines Shaft		▲	
Check Battery Voltage		▲	
Clean Air Filter		▲	
Inspect the Tine Drive Belt for wear			▲
Check Tines for Wear			▲
Change Engine Oil Note: 1 st time 5 hrs.			▲
Replace Air Filter and Pre-cleaner			▲
Replace the Tine Drive Belt			▲
Replace Spark Plug			▲
Grease Wheels			▲

* Cover the Engine Muffler, Carburetor, and Air Filter before using a hose to clean the Tines and Debris Shield. Do not use a power washer; this may force water through the seals of the Actuator.

Lubrication

Your DR TOW-BEHIND ROTOTILLER was lubricated at the Factory. However, periodic lubrication of the Engine, Tines Shaft and Wheels is required.

! WARNING

Never oil or grease pivot points. Viscous lubricants will attract dust and dirt that can cause wear on pivot points. If you feel you must lubricate them, use only dry powdered graphite type lubricants.

Tools and Supplies Needed:

- Grease Gun w/General purpose Grease

Tines Shaft:

Grease the Tines Shaft using a Grease Gun, with General Purpose grease, every 8-10 hours. Apply about ten pumps of Grease in the Grease Fitting (**Figure 20**). Perform this lubrication more often in dry and dusty environments.

Wheels:

Grease the Wheels using a Grease Gun, with General Purpose grease, every 35 hours. Apply Grease to the Grease Fitting on the Wheel Hub just until Grease starts coming out of the Hub (**Figure 21**). Perform this lubrication more often in dry and dusty environments.

Removing and Replacing the Engine Oil

Tools & Supplies Recommended:

- Vacuum Pump Oil Drainer
- Clean Rags
- SAE 30 High Detergent, 16 oz. (0.5L)

Note: Refer to the Engine Owner's manual for more detailed instructions for Engine maintenance. Drain the oil when the Engine is warm. Warm oil drains quickly and completely.

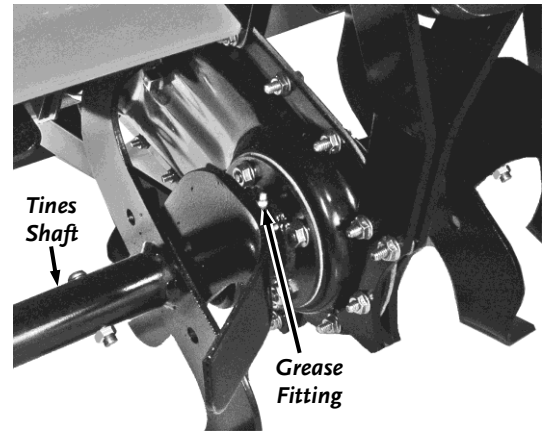

Figure 20

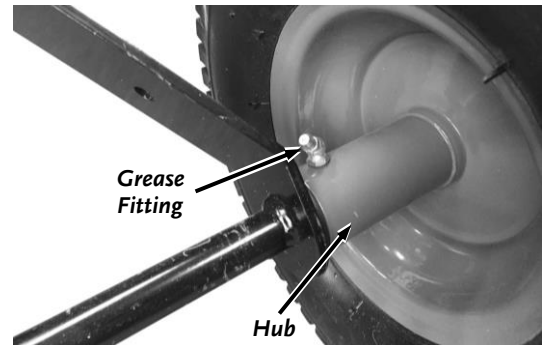

Figure 21

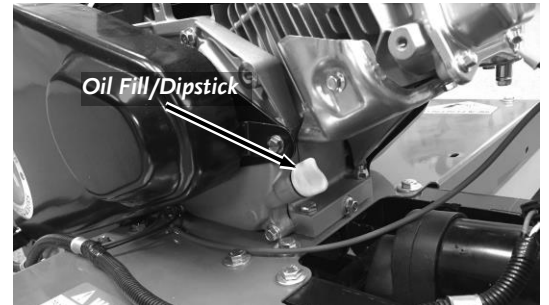

Figure 22

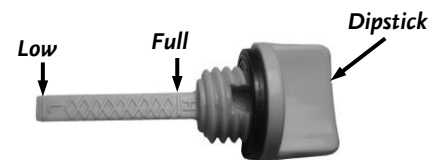

Figure 23

NOTICE

- Fill the reservoir slowly, checking the level frequently, to avoid overfilling.
- To get an accurate reading when checking the oil level:
 - The machine should be on a level surface.
 - The Dipstick should be screwed all the way in to ensure an accurate fluid level reading.

1. Remove the Oil Fill Cap/Dipstick and vacuum the oil from the Engine through the Oil Fill using a Vacuum Pump Oil Drainer (**Figure 22**).

Note: Be sure to use environmentally safe disposal procedures for the used oil.

2. Initially add 12 oz. (1/3 quart) of SAE 30 High Detergent oil, recommended by the Engine Manufacturer, and wait one minute for the oil to settle.

3. Continue adding a few ounces of oil at a time, until the oil reaches the Full line on the Dipstick (**Figure 23**). Be careful not to overfill.

Note: Use SAE 30 High Detergent oil classified "For Service SF, SG, SH, SJ" or higher. Do not use special additives. Other types of oil could cause problems operating your machine. Please refer to your Engine Owner's Manual for detailed oil information.

Battery Care

Proper care can extend the life of a Battery. Follow these recommendations to ensure your Battery's best performance and long life:

- Before charging the Battery, observe its external appearance and keep it clean and dry. Never charge or use a Battery that shows cracks, changes shape, leaks, or is otherwise obviously damaged.
- **Do not allow the Battery to run down completely before charging. Leaving the Battery discharged damages the Battery.** If the machine is not used, charge the Battery every 4 to 6 weeks. Operate the Engine for at least 45 minutes to maintain proper Battery charge.
- Store an unused Battery in a dry area that does not freeze.
- Do not charge an already charged Battery. In theory, you cannot overcharge our Battery with a trickle charger; however, when a Battery is fully charged and the Charger is still on, it generates heat that could be harmful to the Battery. A fully charged Battery will read 12V-13.2V with a voltmeter.
- Do not continue to crank the Engine, or raise and lower the Tines, when the Battery charge is low.
- If the Battery begins to leak, avoid contact with the leaking acid. Place the damaged Battery in a plastic bag, then dispose of it properly.

WARNING

If battery acid does contact your skin or eyes, flush with cool water for at least 15 minutes and call a physician. If you ingest acid, call a physician immediately.

Charging the Battery

Operate the Engine for at least 45 minutes to maintain proper Battery charge. If the Battery loses its charge, you will need to use a trickle Charger (like the DR Battery Charger) to recharge it. The Charger should have an output of 12 volts at no more than 2 amps.

- At 1 amp, the Battery may need charging for as long as 48 hours.
- At 2 amps, the Battery may need charging for as long as 24 hours.

Note: Using the recoil starter and then running the Engine will not recharge a dead or significantly discharged Battery.

Charging the Battery is a simple process. Leave the Battery in your DR TOW-BEHIND ROTOTILLER when you charge it.

To connect a Battery Charger to your DR TOW-BEHIND ROTOTILLER, follow the steps listed below.

1. Attach the Black (-) Wire Terminal from the Charger to the black (-) terminal of the Battery, then attach the Red (+) Wire Terminal to the red (+) Battery terminal.
 2. Plug the Charger into a standard wall outlet.
- Typically, the Battery takes between 6 and 8 hours to fully charge. The Battery does not have a "memory"; so don't worry about overcharging the Battery or charging it too often.
 - You can charge the Battery many times. The Battery lasts longer if you charge it before it is fully drained. Keep it fully charged and at room temperature when not using your DR TOW-BEHIND ROTOTILLER.
 - Once the Battery is charged, pull the plug from the wall outlet and then remove the Charger from your Battery. However, you can leave your Battery plugged in and charging for an extended period.
 - Store the Charger in its self-locking plastic shipping bag. Keep the Charger in a dry location.
 - If the Battery does not hold its charge for very long under normal conditions or it simply won't hold a charge, then replace it. You can purchase replacement Batteries directly from us. To install your new Battery, detach the cables, remove the Battery Clamp, and remove the dead Battery. Next, install the new Battery, replace the Battery Clamp, and attach the cables. Refer to the assembly instructions on page 9 for more details.

NOTICE

When the battery gets old and no longer accepts a charge, remove it from your DR TOW-BEHIND ROTOTILLER. Never leave a dead battery in your machine.

Disposing of the Battery Responsibly

The Battery is a sealed lead-acid Battery. Recycle or dispose of it in an environmentally sound way.

- Do not dispose of a lead-acid Battery in a fire, the Battery may explode or leak.
- Do not dispose of a lead-acid Battery in your regular, household trash. Law in most areas prohibits incinerating, disposing in a landfill, or mixing a sealed lead-acid Battery with household trash.

Recycling a Used Battery

NOTICE

Please dispose of used batteries responsibly, according to your local hazardous materials regulations. Never throw away used batteries in your household trash.

Please dispose of your used Batteries responsibly by recycling them. Call your local Solid Waste Management District or your local waste handler to locate the collection site nearest you. Some collection sites recycle Batteries year-round; others collect them periodically.

You can also visit the Web site of Earth 911 for more information [www.earth911.org]. Once there, click the Municipal HHW link under Hazardous Household Waste, and enter your zip code. The site lists recycling centers located near you.

For a fee, you can recycle your Batteries with the International Metals Reclamation Company. Visit them at www.inmetco.com and click Services; or contact them at: INMETCO, PO Box 720, 245 Portersville Road, Ellwood City, PA 16117, (724) 758-2825; fax (724) 758-2845

To learn more about hazardous waste recycling, visit the Web site for Battery Council International [www.batterycouncil.org] or for the Environmental Protection Agency [www.epa.gov].

Removing and Replacing the Drive Belt

NOTICE

- Use only DR belts on your machine. They have been thoroughly tested and proven for many hours of use.
- Do not move or remove the belt guide (**Figure 25**). If you accidentally alter the position of the belt guide, return it to the correct setting of 6-1/4" vertical inches from the fender to the bottom of guide.

Replace the Tine Drive V-Belt if damaged from slipping under heavy loads or if it shows cracks or frayed edges.

Tools and Supplies Needed:

- 3/8" Socket
1. Remove the two Bolts from the top and rear of the Belt Guard using a 3/8" Socket and remove the Belt Guard (**Figure 24**).
 2. Pull the Tine Clutch Lever Forwards to disengage.
 3. Remove the worn Belt from the Engine Pulley and Transmission Pulley (**Figure 25**).
 4. Reinstall a new Belt around the Engine Pulley and Transmission Pulley and under the Idler Pulley.
 5. Engage the Tine Clutch Lever and replace the Belt Guard.

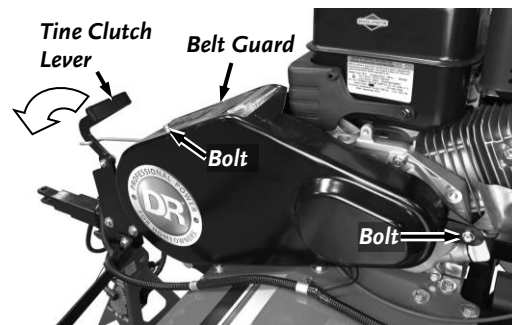

Figure 24

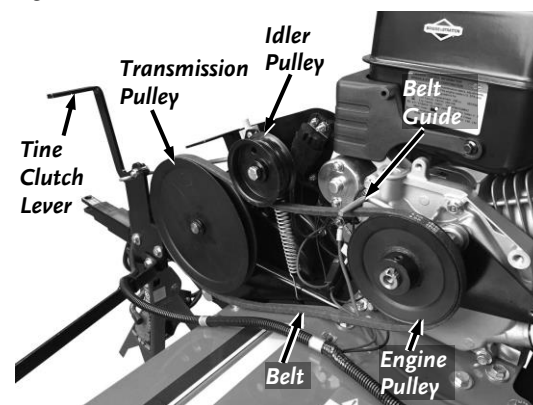

Figure 25

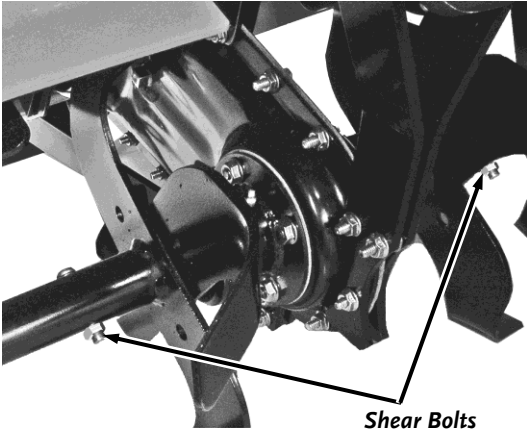

Figure 26

Tine Shear Bolts

- The DR TOW-BEHIND ROTOTILLER drive components are protected from damage by Shear Bolts in the Tine Assemblies (**Figure 26**). The Shear Bolts hold the Tine Assemblies in proper location on the Drive Axles. Should a Tine Assembly strike or pick up a large hidden object and jam, the Shear Bolt holding the Tine Assembly to the drive shaft will shear or break, protecting the drive components of the DR TOW-BEHIND ROTOTILLER from major damage.

! WARNING

Never attempt to use a bolt that is larger or harder than the original shear Bolt.

- Two (2) extra Tine Shear Bolts with Lock Nuts are included with the DR® TOW-BEHIND ROTOTILLER.
- The design of the Tine Shear Bolt is to loosely fit when properly installed.

Tine Operation Check

! WARNING

Before performing this check, you must first shut off the engine, wait five minutes to allow parts to cool and disconnect the spark plug wire, keeping it away from the spark plug.

1. Pull the Tine Clutch Lever Forward to disengage the Tines and raise them up off the ground using the Control Box.
2. Rotate one set of Tines with your hand as you inspect them for damage. Repeat this step for the other set of Tines.
3. Replace the Spark Plug wire.

Chapter 5: Troubleshooting

Most problems are easy to fix. Consult the Troubleshooting Table for common problems and their solutions. If you continue to experience problems, visit our website at www.DRPower.com or call: 1-800-DR-OWNER (376-9637) for support.

Troubleshooting Table

WARNING

When performing any maintenance, you must first shut off the engine, wait five minutes to allow parts to cool and disconnect the spark plug wire, keeping it away from the spark plug.

SYMPTOM	POSSIBLE CAUSE
<i>Recoil will not pull out or is difficult to pull.</i>	<ul style="list-style-type: none"> ⇒ Check that the Tine Drive Clutch is disengaged. ⇒ Check the Engine oil level; the Engine may be seized. ⇒ There may be an oil compression lock in the cylinder. Take out the Spark Plug; hold a rag over the Spark Plug hole and pull the Recoil Cord several times to blow out any oil in the Cylinder. Wipe off the Spark Plug and reinstall it. ⇒ The Recoil may be broken or jammed. Visit our website at www.DRpower.com.
<p><i>The Engine will not start manually.</i></p> <p><i>(Please refer to the Engine Owner's Manual for Engine-specific procedures.)</i></p>	<ul style="list-style-type: none"> ⇒ Check that the Tine Drive Clutch is disengaged. ⇒ Check that the Spark Plug Wire is attached. ⇒ Make sure that the Fuel Shut-Off is in the ON position. ⇒ Check the oil and gas level. See page 11. ⇒ The gas may be old; change it if necessary. Use a fuel stabilizer if you keep gas longer than one month. ⇒ Check the Throttle and Choke settings, adjustment and travel. ⇒ The Spark Plug may be dirty or cracked; change it if necessary. If it's oily, leave it out, hold a rag over the Plug Hole and pull the Recoil Cord several times to blow out any oil in the Cylinder, then wipe off the Plug and reinsert it. ⇒ The Air Filter may be dirty; change it following the procedure in the Engine Owner's Manual. ⇒ If your Engine still won't start, visit our website at www.DRpower.com.
<p><i>The Engine will not start using Electric-Start.</i></p> <p><i>(Please refer to the Engine Owner's Manual for engine-specific procedures.)</i></p>	<ul style="list-style-type: none"> ⇒ Check all the items under the section called Electric-Starting on page 14. ⇒ Check the previous section on Manual Starting for possible causes. ⇒ Check the Fuse of the in-line Circuit Breaker that is under the Belt Cover. Check the Fuse for continuity with a Multimeter. ⇒ Check the wire connections, especially the ground connection. This is the large black wire leading from the Battery and connected to the Engine. ⇒ Check the wire connections to the Solenoid. To avoid sparks, first disconnect the black Battery ground wire. Check to be sure that all the connections are clean and tight. Reconnect the Battery ground wire. ⇒ Check the ground connection on the Solenoid where it bolts to the Frame. Using a Wrench or Socket, tighten the Bolts to ensure a good connection to the Frame. ⇒ The Battery may not be charged. Check the voltage yourself or at a service station. If it is low, charge it with a 12-volt, 1 to 2 Amp trickle charger. If you do not use your machine for at least 45 minutes at a time, the Battery may need to be periodically charged. See the Battery Care section on page 20. ⇒ If the Battery is charged and your DR TOW-BEHIND ROTOTILLER still will not start, visit our website at www.DRpower.com.

! WARNING

When performing any maintenance, you must first shut off the engine, wait five minutes to allow parts to cool and disconnect the spark plug wire, keeping it away from the spark plug.

SYMPTOM	POSSIBLE CAUSE
<i>The Engine lacks power or is not running smoothly.</i> <i>(Please refer to the Engine Owner's Manual for engine-specific procedures.)</i>	<ul style="list-style-type: none">⇒ Check the Throttle; it should be set in the FAST position.⇒ The Air Filter may be dirty; change it following the procedure in the Engine Owner's Manual.⇒ The Spark Plug may be dirty or cracked; change it if necessary. If it's oily, leave it out, hold a rag over the Plug hole and pull the Recoil Cord several times to blow out any oil in the Cylinder, then wipe off the Plug and reinsert it.⇒ The gas may be old; change it if necessary. Use a fuel stabilizer if you keep gas longer than one month.⇒ The Engine oil may be dirty. Change it if necessary, following the procedure on page 19.⇒ If your Engine still lacks power, visit our website at www.DRpower.com.
<i>Engine smokes.</i>	<ul style="list-style-type: none">⇒ Check the oil level and adjust as needed.⇒ The Air Filter may be dirty; change it following the procedure in the Engine Owner's Manual.⇒ You may be using the wrong oil. Refer to your Engine Owner's Manual for detailed information.⇒ Clean the Engine cooling fins and the carburetor housing if they are dirty.⇒ If the Engine still smokes, visit our website at www.DRpower.com.
<i>The Engine runs well but the Tines won't move.</i>	<ul style="list-style-type: none">⇒ The Tine Drive Clutch is not engaged.⇒ The Tine Drive V-Belt is off the pulleys or broken. See page 21.
<i>The Engine runs well but labors when tilling.</i>	<ul style="list-style-type: none">⇒ Operator is being too aggressive; raise the Tines.⇒ Be sure the Engine Throttle is set on the Fast (RABBIT) position.
<i>Excessive bounce and difficult handling.</i>	<ul style="list-style-type: none">⇒ The area you are tilling may be too dry and hard. Moisten the ground or wait for conditions that are more favorable.⇒ Be sure the Engine Throttle is set on the Fast (RABBIT) position.⇒ If your DR TOW-BEHIND ROTOTILLER still bounces, visit our website at www.DRpower.com.
<i>The tilled soil balls up or clumps.</i>	<ul style="list-style-type: none">⇒ The ground that you are trying to till is too moist. See Tilling Tips on page 16.
<i>Tow vehicle surges forward.</i>	<ul style="list-style-type: none">⇒ Tines set too deep; Set tines to appropriate depth of 1 to 2 inches per pass.⇒ Tines engaged while on ground or in soil; Ensure tines are raised and are not in contact with anything before engaging.⇒ Tines too low and engaged when coming to untilled area at the end of tilled area; stop the tow vehicle so tiller tines are short of the untilled area, disengage and lift the Tines up before continuing.⇒ Tilling in area with large roots, surface rocks or other debris; Remove obstacles if possible. If obstacles cannot be removed, do not use tiller in that area.⇒ Rotating tines lowered to fast; Lower tines slowly into area to be tilled to prevent overload especially untilled sod.

Notes:

Chapter 6: Parts Lists, Schematic Diagrams And Warranty

Parts List - Main Assembly

Note: Part numbers listed are available through DR Power Equipment.

Ref#	Part#	Description	Ref#	Part#	Description
1	A0005707744	DR Tiller Tine Drive Assembly	41	MGHDW008	8" Zip Tie with Hole
2	231210	Chassis - LH - TPT	42	A0001497252	Label-Operating Premier/Pro 36T
3	231220	Chassis - RH - TPT	43	110731	Nut-Lock Nylon 1/4-20
4	111491	Bolt-HCS 1/4-20 X 1 Gr5 ZP	44	G063480	Nut Hex Lock #8-32 Nylock
5	233040	Nut, Flang Hex 1/4-20, Center Lock	45	A0000567497	Label-Pro 36t
6	A0005506408	ASS'Y-Hitch Bracket W/Tow Bar	46	G022287	Screw, HHC 1/4-20 X 3/4 G5
7	111581	Bolt-HCS 5/16-18 X 1 GR5 ZP	47	G036919	Screw, PPHM #8-32 X 5/8
8	110761	Nut-Lock Nylon 5/16-18	48	376580	Bracket, Hitch Ext TPT
9	231240	Cover - Belt Drive -Tiller ES	49	A0005247660	Pin-Bent Arm 1/2 X 3
10	231330	Bracket - Idler Arm - TPT	50	160031	Pin-Hitch Clip 1/2-9/16
11	236170	Switch-Interlock	51	224521	Label-Tines Warning
12	118731	Nut-Lock Nylon 10-24	52	110721	Nut, Nylon Lock, 1/2-13
13	114781	Screw-Panhead 10-24 X 5/8 In	53	376590	Plate - Guard Mounting - TPT
14	276611	Pulley - Flat Idler - 2-3/4 Dia	54	G050190	Washer, Flat, .344id X 1.0od
15	123341	Bolt-HCS 3/8-16 X 1-3/4 GR5 ZP	55	055934C	Clamp, STL/VNL, .5 X .406 Z
16	110751	Nut-Lock Nylon 3/8-16	56	233060	Bolt-HCS, 5/16-24 X 1 W/Lock Patch
17	231230	Rod, Clutch TPT	57	179121	Bolt-Trilobe, 1/4-20 X 1/2
18	A0005506411	Fender W/Labels-Pro 36T Tiller	58	323820	Spacer-Shoulder-Idler
19	A0005512303	Engine W/Labels-DR 6.6hp 223cc E/S R225	59	111521	Bolt-HCS, 3/8-16 X 1 GR5 ZP
20	233110	Rod, V-Belt Guide	60	110781	Nut - Finish - 5/16-24 ZP
21	112411	Washer-Flat 5/16 USS	61	234191	Pin, Hair Cotter 1/8 X 1-5/8
22	A0000585488	Label - DR Logo Red 4.5in	62	231280	Cap, Fender End, LH TPT
23	233160	Nut Hex 5/16-18 Flanged Loc	63	413850	Fender, Tube Assy TPT
24	224511	Label-Guards & Shields Warning	64	376560	Tube Frame Assembly-TPT- Pro
25	232660	Clutch Lever TPT	65	231290	Angle Reinforcement TPT
26	232560	Actuator, Tow behind TLR	66	297240	Bracket, Rear Case TPT
27	134431	Bolt, HCS, 5/16-18 X 1-1/2 Gr5 ZP	67	231310	Brace, Front Case TPT
28	112381	Washer-Flat 1/4 USS	68	229091	Bolt - HCS 1/2-13 X 1 1/2 Gr5 ZP
29	233620	Pin-Clevis, 1/2 X 2 ZP	69	MGHDW321	Nut, 1/2-13, Top Lock, Z
30	337251	Key Square 3/16 X 1.75 Wh1	70	A0000057791	Bolt-5/8-11 X 7in-Hex-Zp
31	G061342	Screw HHC 1/2-13 X 1-1/4 G5	71	101311	Nut-Nylon Lock 5/8-11
32	120171	Screw-Set 5/16-18 X 5/16 In	72	231390	Spacer .778id X 1.00od X 4.7
33	233570	Pulley, 8" OD	73	231350	Footguard, Tiller TPT
34	371691	Key - Ansi #605 Woodruff - 3/16 X 5/8"	74	101471	Bolt-HCS 5/16-18x2 1/4 Gr5 ZP
35	111241	Ring-Retaining 5/8"	75	112431	Washer-Lock 5/16
36	114431	Belt, 41450 12 In X 45 In	76	231270	Cap, Fender End, RH TPT
37	232720	Extension Spring			
38	A0005506409	Cover-Belt W/Labels-36T Tiller			
39	311161	Bolt-HWH 5/16-18 X .75 Taptite ZP			
40	376460	Assy - Safe Start Module			

Schematic Diagram - Main Assembly

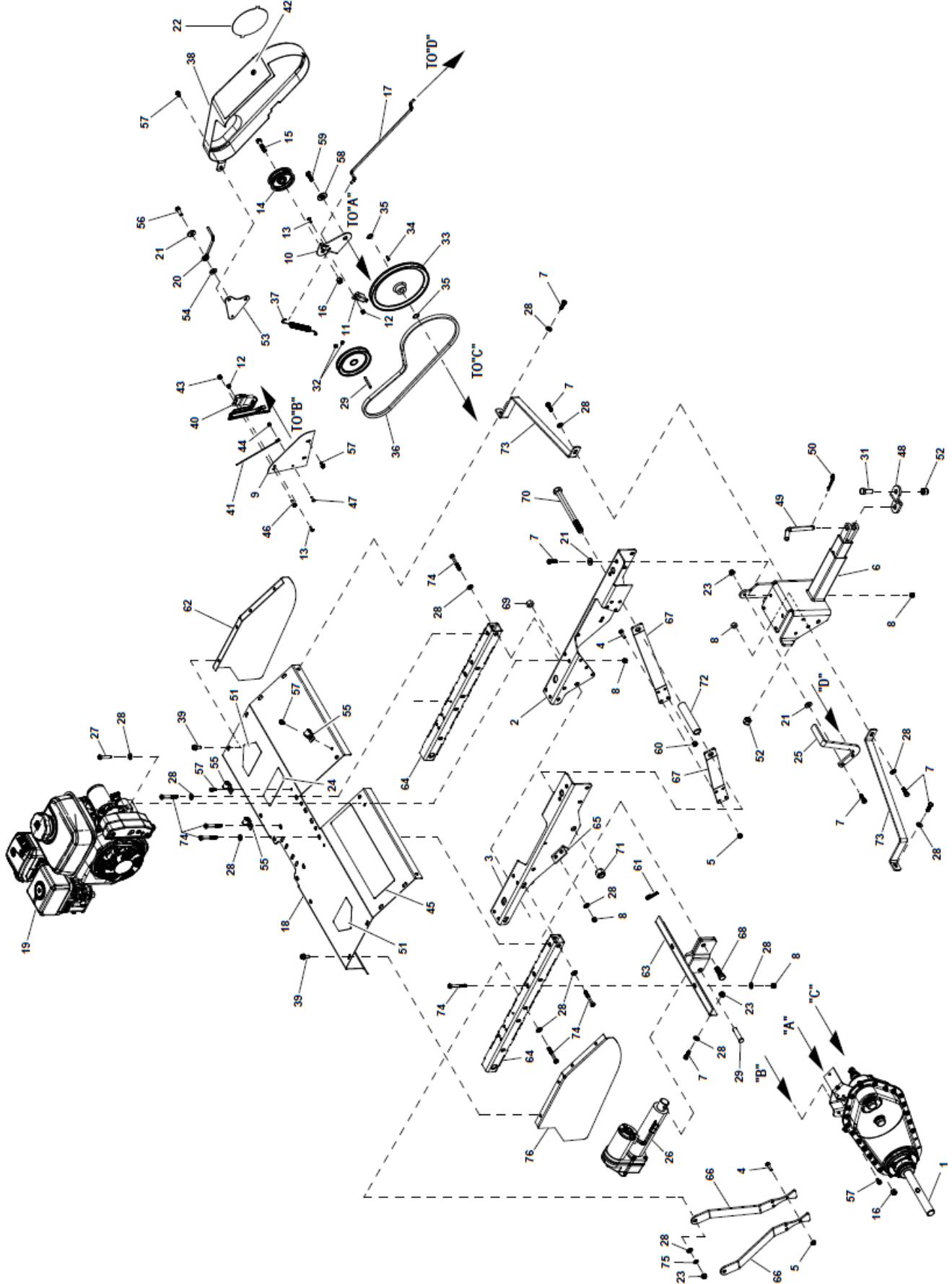

Parts List and Schematic Diagram -Tine Drive Transmission Assembly

Note: Part numbers listed are available through DR Power Equipment.

Ref#	Part#	Description	Ref#	Part#	Description
1	303150	Assy, Tine Shaft & Sprocket TPT	13	233400	Felt Washer, .985 X 1.515, TPT
2	233440	Assy, Idler Shaft TPT	14	G022287	Screw, HHC, 1/4-20 X 3/4, G5
3	330300	Input Shaft Assy, TPT Premier	15	365211	Bolt, Hex Flange, 1/4-20 X 5/8 ZP
4	233520	Drive Housing Assy, RH TPT	16	233040	Nut, Flng Hex, 1/4-20 Center Lock
5	233450	Chain, Roller Short TPT	17	231360	Tine Assy, Left Tiller TPT
6	233410	Chain, Roller Long TPT	18	231370	Tine Assy, Right Tiller TPT
7	233490	Gasket, Drive Housing TPT	19	376470	Bolt, Hex, 3/8-16 X 2, FT GR2
8	233530	Drive Housing Assy, LH TPT	20	110751	Nut, Lock Nylon, 3/8-16
9	233390	Gasket, Flange TPT	21	233420	Washer, Thrust, .64 X .937
10	3031409	Bearing And Flange Assy	22	231380	Cap-TPT
11	233470	Bracket, Belt Guard & Idler	23	233540	Seal, Grease 5/8 Id X 7/8 Od X .15 Thk
12	233160	Nut,Hex, 5/16-18, Flanged Lock	24	G026925	Plug, Std Pipe, 3/8, Steel, SQ HD

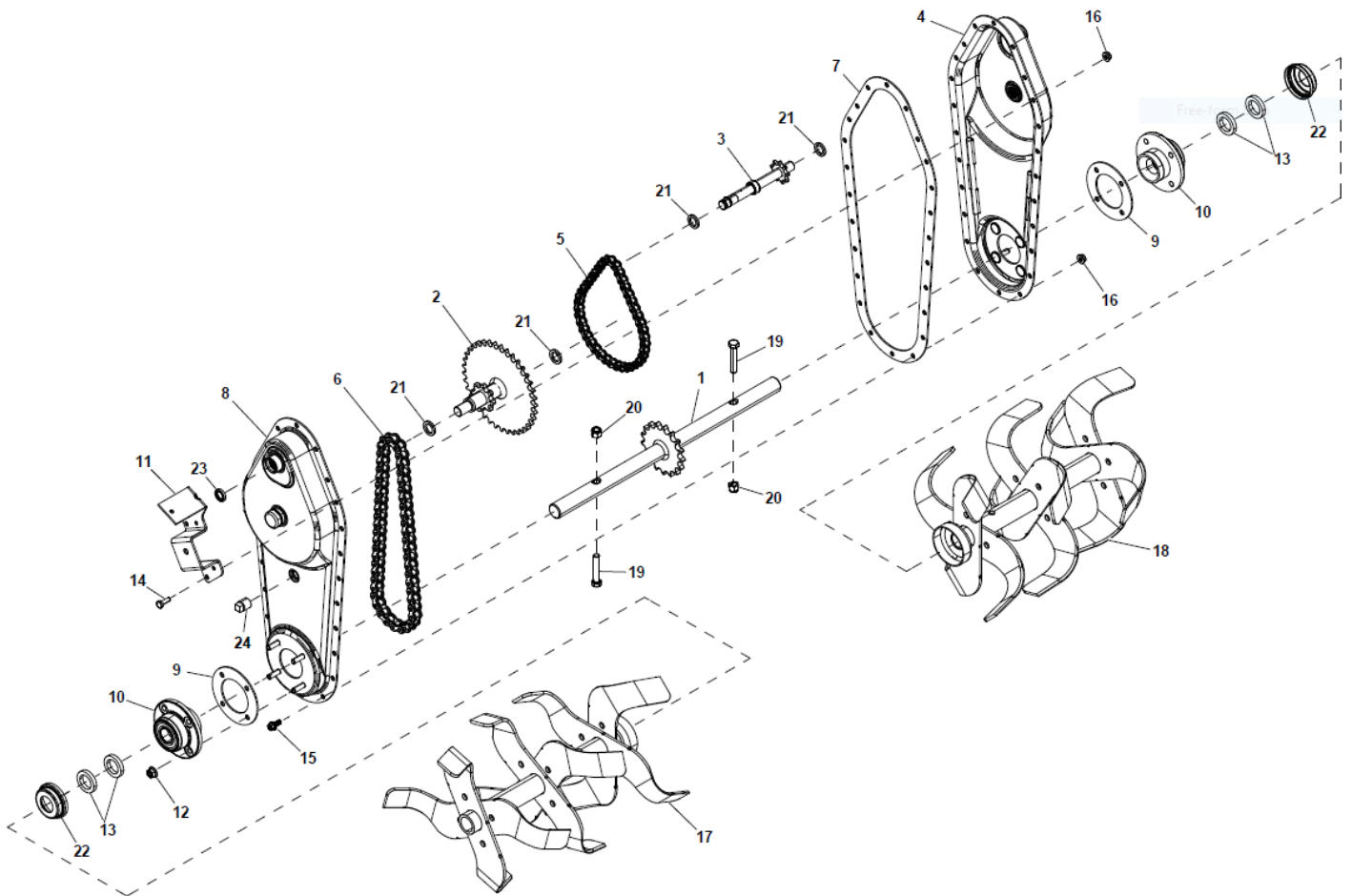

Parts List and Schematic Diagram - Axle Assembly

Ref#	Part#	Description	Ref#	Part#	Description
1	233040	Nut, Flng Hex, 1/4-20 Center Lock	10	264480	Washer, .785 X 1.57 X .057
2	376540	Wire, Battery Cable, Red (Not Shown)	11	233290	Wheel, 15 X 6-3/4, TPT
3	376510	Bracket, Battery Box	12	0D4999	Pin, Cotter, 1/8 X 1-1/4, ZP
4	114561	Bolt, HCS, 1/4-20 X 2 IN, GR5 ZP	13	231320	Axle, Pivot, TPT
5	376520	Strap, Battery Hold Down	14	233190	Wheel Mount Assy
6	G026586	Screw, HHC, 1/4-20 X 5, G5	15	404570	Asm, Lift Control Box
7	134471	Battery, 9 AH, 12V	16	378541	Universal Battery Charger
8	376530	Wire, Battery Cable, Black (Not Shown)	17	310540	Grease Zerk, Roto Hog, Wheel
9	186551	Pin, Cotter, 3/16x2 IN	18	110731	Nut, Lock, Nylon 1/4-20

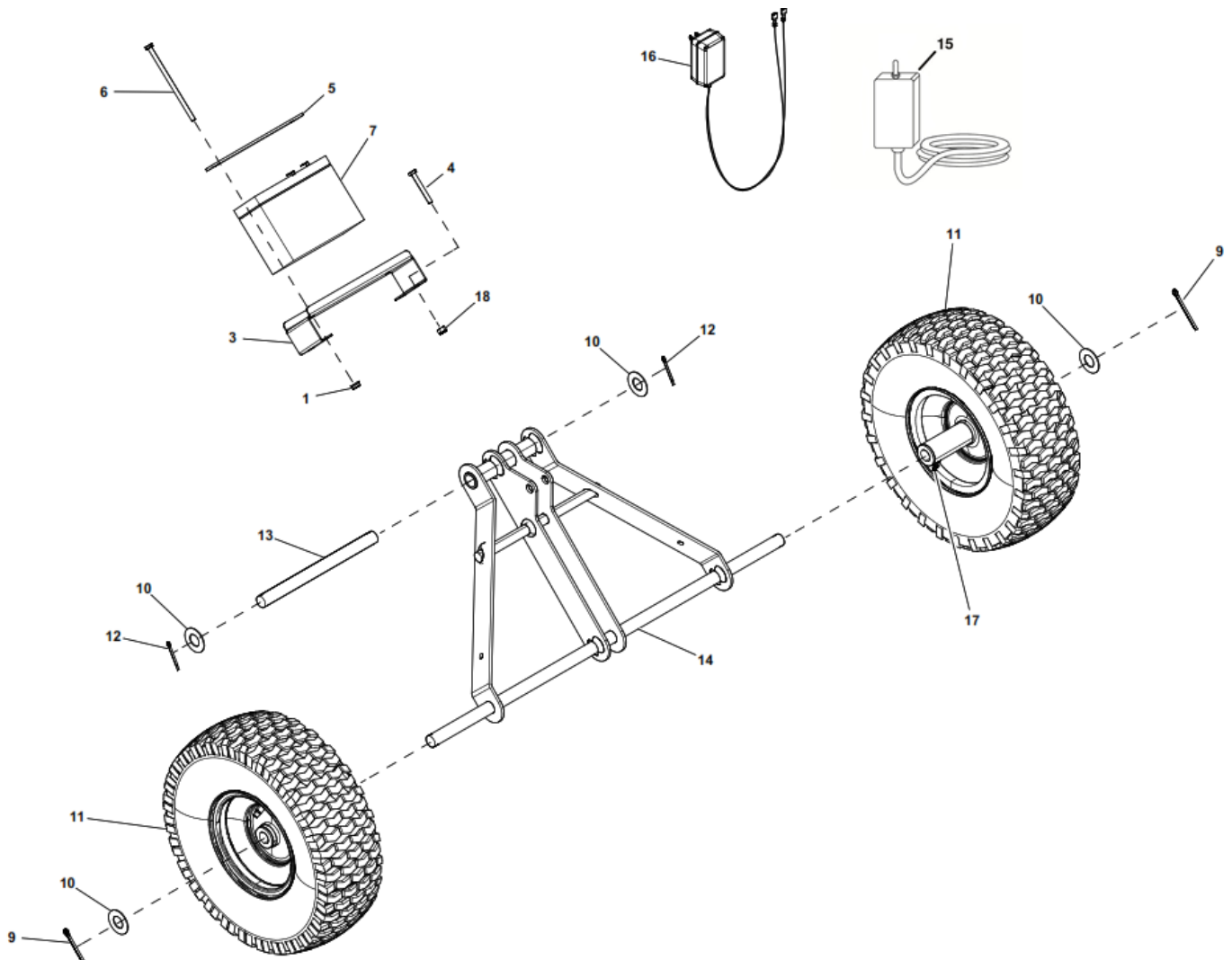

Wiring Diagram

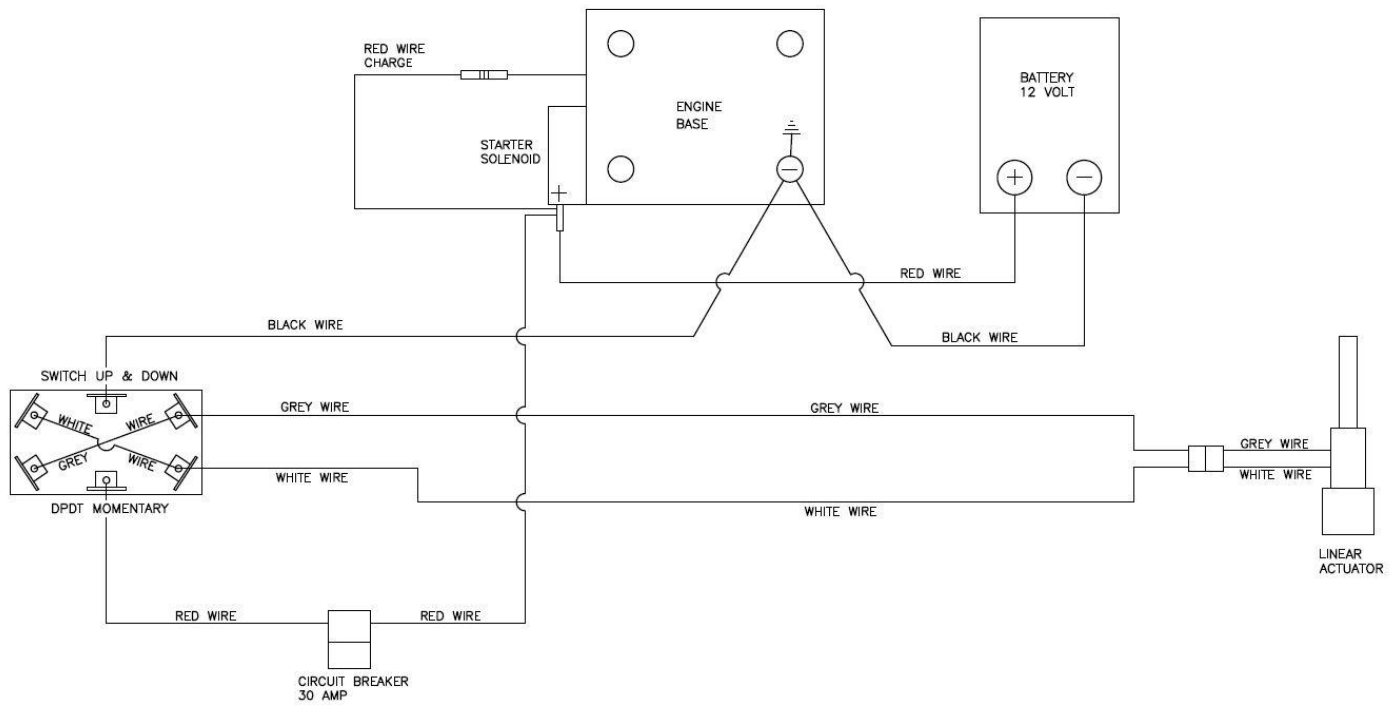

DR[®] TOW-BEHIND ROTOTILLER



2-Year Limited Warranty

Terms and Conditions

The **DR[®]** TOW-BEHIND ROTOTILLER is warranted for two (2) years against defects in materials or workmanship when put to ordinary and normal consumer use; ninety (90) days for any other use. The Engine Manufacturer warrants the Engine separately.

For the purposes of all the above warranties, "ordinary and normal consumer use" refers to non-commercial residential use and does not include misuse, accidents, or damage due to inadequate maintenance.

DR[®] Power Equipment certifies that the **DR[®]** TOW-BEHIND ROTOTILLER is fit for ordinary purposes for which a product of this type is used. **DR[®]** Power Equipment, however, limits the implied warranties of merchantability and fitness in duration to a period of two (2) years in consumer use, ninety (90) days for any other use.

The 2-Year Limited Warranty on the **DR[®]** TOW-BEHIND ROTOTILLER starts on the date the machine ships from our factory. The 2-Year Limited Warranty is applicable only to the original owner.

The warranty holder is responsible for the performance of the required maintenance as defined by the manufacturer's owner manuals. The warranty holder is responsible for replacement of normally wearing parts such as the Drive Belt, Tines, Tires, Air Filter, and Battery. Attachments and accessories to the machine are not covered by this warranty.

During the warranty period, the warranty holder is responsible for the machine transportation charges, if required. During the warranty period, warranty parts will ship by standard method at no charge to the warranty holder. Expedited shipping of warranty parts is the responsibility of the warranty holder.

SOME STATES DO NOT ALLOW LIMITATIONS ON THE LENGTH OF IMPLIED WARRANTIES, SO THE ABOVE LIMITATIONS MAY NOT APPLY TO YOU.

DR[®] Power Equipment shall not be liable under any circumstances for any **incidental or consequential damages or expenses** of any kind, including, but not limited to, cost of equipment rentals, loss of profit, or cost of hiring services to perform tasks normally performed by the **DR[®]** TOW-BEHIND ROTOTILLER.

SOME STATES DO NOT ALLOW THE EXCLUSION OR LIMITATION OF INCIDENTAL OR CONSEQUENTIAL DAMAGES, SO THE ABOVE LIMITATIONS MAY NOT APPLY TO YOU.

THIS WARRANTY GIVES YOU SPECIFIC LEGAL RIGHTS, AND YOU HAVE OTHER RIGHTS, WHICH VARY FROM STATE TO STATE.

Daily Checklist for the DR TOW-BEHIND ROTOTILLER

WARNING

When performing any maintenance, you must first shut off the engine, wait five minutes to allow parts to cool and disconnect the spark plug wire, keeping it away from the spark plug.

To help maintain your DR TOW-BEHIND ROTOTILLER for optimum performance, we recommend you follow this checklist each time you use your machine.

- [] OIL: With the machine on a level surface, remove the Oil Fill Cap and check the oil level.
Fill the reservoir until the oil reaches just below the threads with SAE 30 HD motor oil. See page 11.
- [] GAS: Fill the gas tank with fresh, unleaded gasoline. See page 11.
- [] ENGINE: It is very important to keep the engine clean. Remove dirt and other debris from the Engine Cooling Fins and Debris Shield. A dirty Engine retains heat and can cause damage to internal Engine components.
- [] HARDWARE: Check all nuts and bolts to be sure that the components are secure.
- [] FRAME: Check all welds to be sure that the Frame is intact and secure.
- [] TINES: Make sure that the Tine Assemblies and Debris Shield are free of accumulated debris.

End of Season and Storage

WARNING

When performing any maintenance, you must first shut off the engine, wait five minutes to allow parts to cool and disconnect the spark plug wire, keeping it away from the spark plug.

Note: Please refer to the Engine Owner's Manual for Engine-specific procedures.

- Change the Engine oil.
- If your DR TOW-BEHIND ROTOTILLER will be idle for more than 30 days, we recommend using a gas stabilizer. This will prevent sediment from gumming up the carburetor. If there is dirt or moisture in the gas or tank, remove it by draining the tank. Completely fill the tank with fresh, unleaded gas and add the appropriate amount of stabilizer or gasoline additive. Run the Engine for a short time to allow the additive to circulate.
- Remove the Spark Plug and pour about 1 ounce of motor oil into the cylinder hole. Replace the Plug and pull the Recoil Starter Rope until you feel strong resistance. This will coat the Piston and seat the Valves to prevent moisture buildup.
- Clean or replace the Engine Air Filter. Reference the Engine Owner's Manual.
- Clean dirt and debris from the Engine Cylinder Head Cooling Fins, Debris Screen, and Muffler.
- Clean out residual debris from under the Debris Shield and Tine Assemblies.
- Lubricate the Tine Assemblies and Wheels. See page 19.
- Touchup all rusted or chipped paint surfaces. Sand them lightly before painting.
- Be sure all Nuts, Bolts, and Screws are securely fastened.
- Inspect moving parts and the Tine Drive Belt for damage and wear; replace if necessary.
- Store the Battery in a dry area that will not freeze. If you will not use the machine over a long period, charge the battery every four to six weeks. See page 20.
- If possible, store your DR TOW-BEHIND ROTOTILLER inside, but not near an open flame or spark such as found in a water heater.
- After the DR TOW-BEHIND ROTOTILLER has cooled, cover the machine with a suitable protective cover that does not retain moisture. Do not use plastic as this material cannot breathe; it also allows condensation to form, which will cause your machine to rust.



800 HINESBURG ROAD, SOUTH BURLINGTON, VERMONT 05403