

DR[®] POWER GRADER

SAFETY & OPERATING INSTRUCTIONS

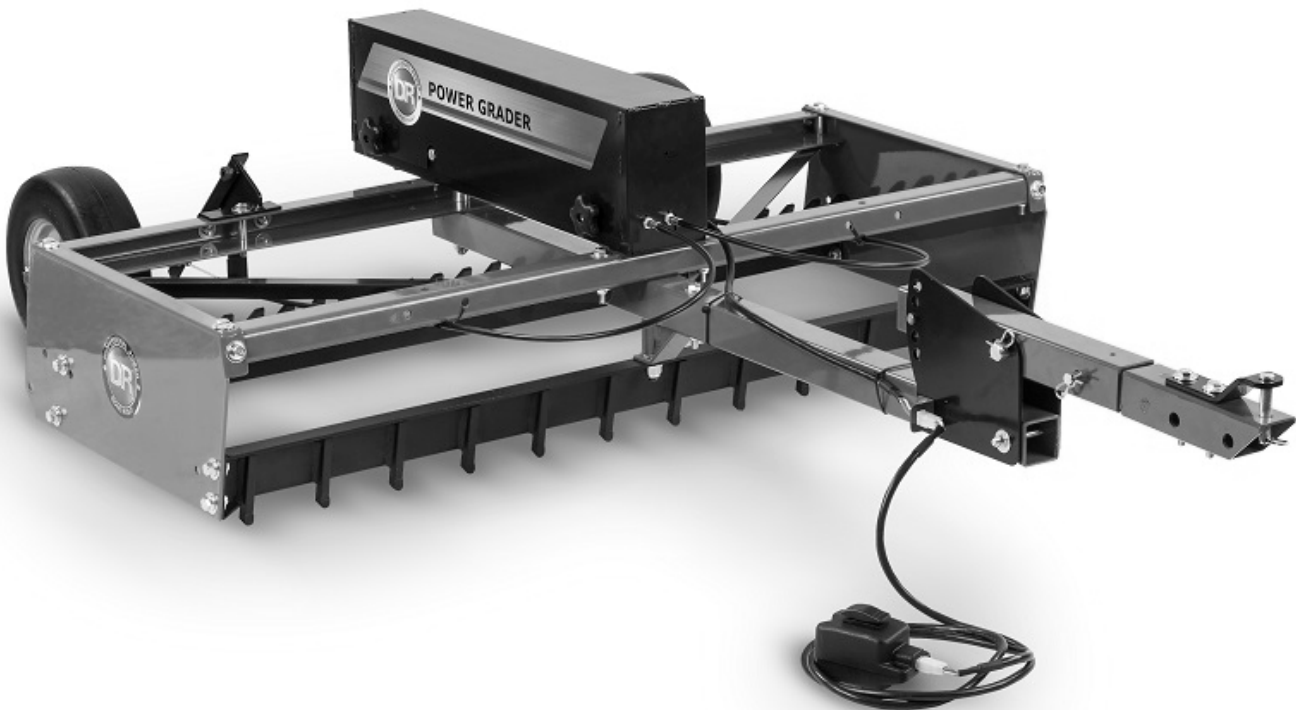

Serial No. _____

Order No. _____

Original Language

DR Power Equipment
Toll-free phone: 1-800-DR-OWNER (376-9637)
Fax: 1-802-877-1213
Website: www.DRpower.com

⚠ WARNING

Read and understand this manual and all instructions before operating the DR POWER GRADER.

Table of Contents

Chapter 1: General Safety Rules..... 3

Chapter 2: Setting Up the DR POWER GRADER..... 6

Chapter 3: Operating The DR POWER GRADER 17

Chapter 4: Maintaining The DR POWER GRADER 21

Chapter 5: Troubleshooting 23

Chapter 6: Parts Lists, Schematic Diagrams and Warranty..... 24

Conventions used in this manual

! WARNING

This indicates a hazardous situation which, if not avoided, could result in death or serious injury.

! CAUTION

This indicates a hazardous situation which, if not avoided, could result in minor or moderate injury.

NOTICE

This information is important in the proper use of your machine. Failure to follow this instruction could result in damage to your machine or property.

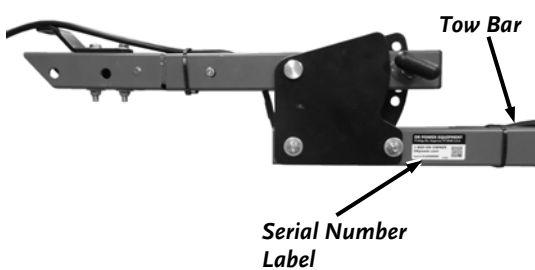

Figure 1

Serial Number and Order Number

A Serial Number is used to identify your machine and is located on the Serial Number Label on your machine (**Figure 1**). An Order Number is used to check and maintain your order history and is located on the upper left portion of your packing slip. For your convenience and easy reference, enter the Serial Number and Order Number in the space provided on the front cover of this manual.

Additional Information and Potential Changes

DR Power Equipment reserves the right to discontinue, change, and improve its products at any time without notice or obligation to the purchaser. The descriptions and specifications contained in this manual were in effect at printing. Equipment described within this manual may be optional. Some illustrations may not be applicable to your machine.

Chapter 1: General Safety Rules

WARNING

Read this safety & operating Instructions manual before you use the DR POWER GRADER. Become familiar with the operation and service recommendations to ensure the best performance from your machine. If you have any questions or need assistance, please contact us at www.DRpower.com or call toll-free 1-800-DR-OWNER (376-9637) and one of our Technical Support Representatives will be happy to help you.

Labels

Your DR POWER GRADER carries prominent labels as reminders for its proper and safe use. Shown below are copies of all the Safety and Information labels that appear on the equipment. Take a moment to study them and make a note of their location on your POWER GRADER as you set up and before you operate the unit. Replace damaged or missing safety and information labels immediately.

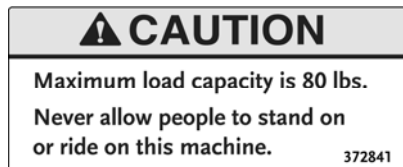

#37284



#38913

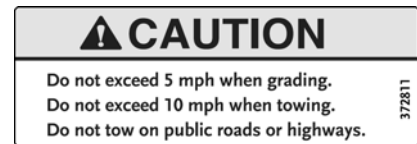

#37281

Protecting Yourself and Those Around You

WARNING

Always take the following precautions when operating this grader:

- Always wear protective goggles or safety glasses with side shields while grading to protect your eyes from possible thrown bits of dirt or gravel.
 - Wear shoes with non-slip treads when using your DR Power Grader. If you have safety shoes, we recommend wearing them. Do not use the grader while barefoot or wearing open sandals.
 - Wear a helmet when operating an ATV.
-

Safety for Children and Pets

WARNING

Tragic accidents can occur if the operator is not alert to the presence of children and pets. Children and pets are often attracted to the grading activity. **Never** assume that children or pets will remain where you last saw them.

- Keep children out of the grading area and under the watchful care of a responsible adult.
 - Be alert, stop and turn the tow vehicle off if children or pets enter the work area.
 - Never allow children to operate the DR Power Grader.
 - Never allow children or pets to ride on the tow vehicle or the DR Power Grader.
-

Operating the DR POWER GRADER Safely

WARNING

You must operate the Power Grader safely. Unsafe operation can create a number of hazards for you. Always take the following precautions when using this Grader:

- Read, understand, and follow all instructions in this manual. Be thoroughly familiar with the controls and the proper use of your Grader before using.
 - Thoroughly inspect the area where your Grader will be used, and remove all large stones, sticks, wire, pet supplies, lawn toys, and any other foreign objects that you could run over. Also, note the location of stumps and other possible hazards that you should avoid during operation.
 - Watch for traffic when operating in or near roadways. Pay extra attention when operating near public roadways.
 - When operating in a roadway, we suggest that you put out obstructions (marker cones or pails) to divert any traffic away from your work area.
 - Be aware of your surroundings when operating the DR Power Grader, e.g. ditches, culverts, drop-offs, and hills.
 - Never allow people who are unfamiliar with these instructions to use the DR Power Grader.
 - To be safe, do not operate the grader near small children or pets, and never allow children to operate the Power Grader. Stop the grading action when another person or pet approaches.
 - Do not allow people to ride on the Grader.
 - If you have to stop to remove any debris from the Grader, always shut off the tow vehicle's engine and set the parking brake.
 - Do not, under any conditions, remove, bend, cut, fit, weld, or otherwise alter standard parts on the DR Power Grader. Modifications to your machine could cause personal injuries and will void your warranty.
 - While using the DR Power Grader, don't hurry or take things for granted.
 - Do not operate the Grader when under the influence of alcohol or medication.
 - Use the DR Power Grader only in daylight or good artificial light.
-

Safety with Electric-Powered Machines

WARNING

Never overlook the hazards of electricity. Always follow these precautions:

- Never attempt to open the motor assembly. Never attempt any electrical repairs yourself. If in doubt, consult a qualified electrician, contact us at www.DRpower.com or call 1-800-dr-owner (376-9637) for help or information.
 - Never tamper with safety devices. Check their proper operation regularly.
-

CAUTION

The DR Power Grader must be operated safely to prevent or minimize the risk of minor or moderate injury. Unsafe operation can create a number of hazards for you. Always take the following precautions when operating this Power Grader:

- Keep in mind that the operator or user is responsible for accidents or hazards occurring to other people, their property, and themselves.
 - Do not use the DR Power Grader to drag, tow, or carry items.
 - Never operate the DR Power Grader with a truck (2wd or 4wd); doing so will void the DR Power Grader warranty.
 - Never leave the DR Power Grader unattended. If you leave the area, shut off the tow vehicle, and remove the key.
 - Keep all nuts and bolts tight and keep the equipment and attachments in good operating condition.
 - Use only manufacturer-recommended replacement parts.
 - Do not use the DR Power Grader in a manner not in accordance with these instructions.
-

Handling the Battery Safely

WARNING

- Use only the 12-volt, lead-acid, rechargeable battery and the 12-volt battery charger that shipped with your grader, or the DR Power Equipment replacement. Using the wrong type of battery or a charger, other than the DR Power Equipment charger, could cause a fire or explosion resulting in serious injury.
 - Never lift or carry the battery by the wires or connectors. This can damage the battery and possibly cause a fire resulting in serious injury. Lift and carry the battery by the case only.
 - Only adults should handle the battery. The battery is heavy and contains sulfuric acid (electrolyte). Dropping the battery could result in serious injury. Have a firm grip and use caution when removing or changing the battery.
 - Batteries contain sulfuric acid. To prevent burns, avoid contact with skin, eyes, and clothing. To prevent fire or explosion keep sparks and open flames away from the battery.
 - Exercise care in handling the battery in order not to short-circuit it with conducting materials such as rings, bracelets, and keys. When short-circuited, the battery or conductor may overheat and cause burns.
 - Please dispose of used batteries responsibly, according to your local hazardous materials regulations. Never throw away used batteries in your household trash. Bring them to a recycling center or household hazardous waste depot for proper disposal. Please refer to “recycling a used battery”, on page 22, for more information.
-

Safely Charging the Battery

WARNING

- Examine the charger and the connectors for excessive wear or damage each time you charge the battery. If you determine there is a problem, do not use the charger or the battery until you have replaced the worn or damaged part.
 - Never allow children to charge the battery. The electricity involved in charging the battery could injure a child.
 - Never charge the battery in the rain or in wet locations.
-

NOTICE

- Never allow the battery to completely discharge; charge the battery before this happens.
 - Charge the battery before storing your DR Power Grader. Do not leave the battery discharged, as this can ruin it.
-

California Proposition 65

WARNING

California Proposition 65:

- This product contains or emits chemicals known to the State of California to cause cancer, birth defects, and other reproductive harm.
-

A Note to All Users

No list of warnings and cautions can be all-inclusive. If situations occur that are not covered by this manual, the operator must apply common sense and operate this DR POWER GRADER in a safe manner. Contact us at www.DRpower.com or call 1-800-DR-OWNER (376-9637) for assistance.

Chapter 2: Setting Up the DR POWER GRADER

It may be helpful to familiarize yourself with the controls and features of your DR POWER GRADER as shown in Figure 2 before beginning these procedures. If you have any questions at all, please feel free to contact us at www.DRpower.com.

DR POWER GRADER Controls and Features

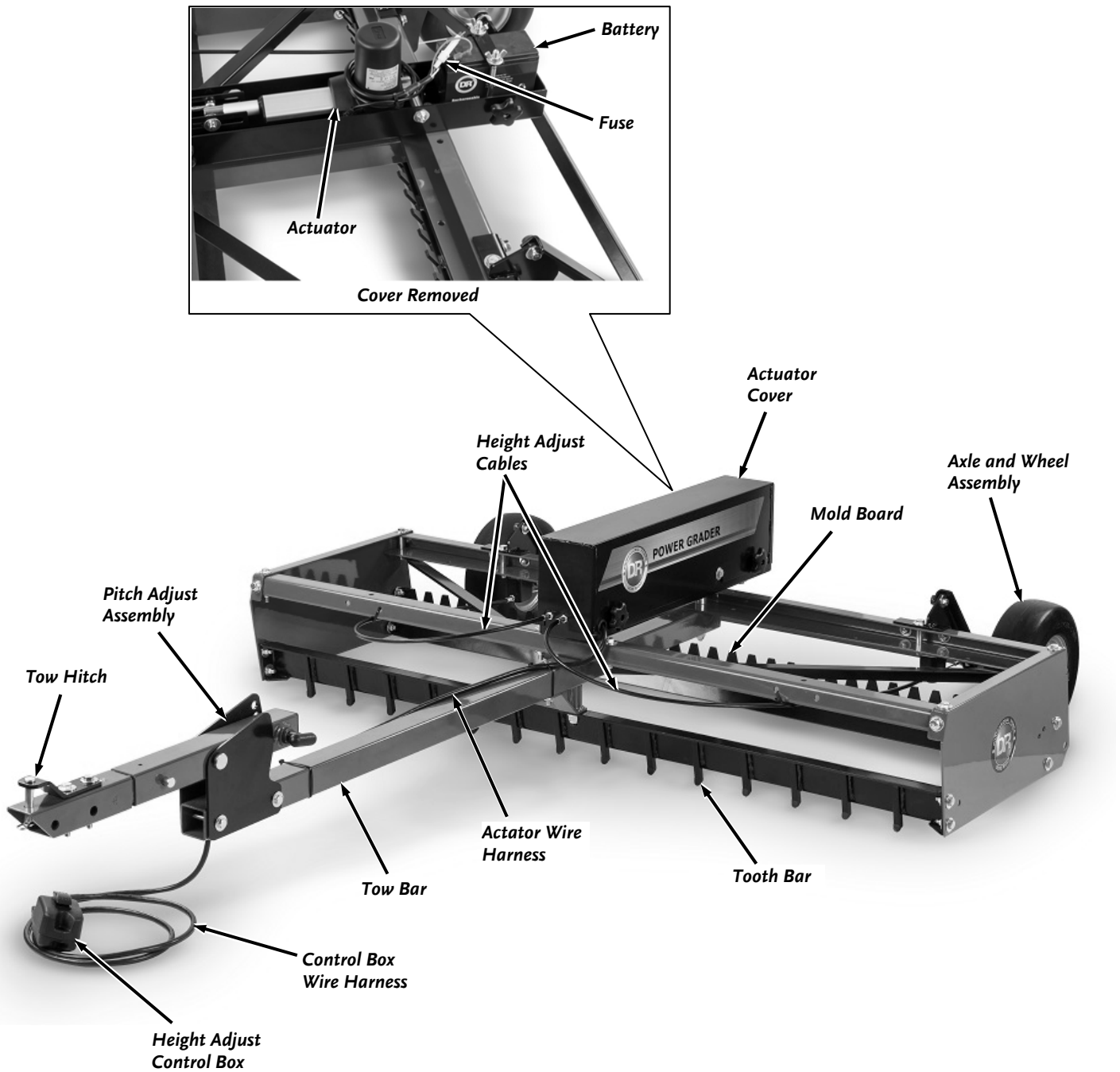

Figure 2

Specifications

	48" Model	60" Model
Teeth	12 ea.	14 ea.
Material	90/10 Tungsten/Carbide tipped 4142 Hardened Alloy Steel	90/10 Tungsten/Carbide tipped 4142 Hardened Alloy Steel
Distance Between Teeth	4"	4"
Length	3-5/8"	3-5/8"
Mold Board	Cold rolled Steel, .25" Thick	Cold rolled Steel, .25" Thick
Reversible	Grading or grooming blade types	Grading or grooming blade types
Adjustable Angle	50 degrees for aggressive cutting 90 degrees for light dragging/mixing 105 degrees for light material/grooming)	50 degrees for aggressive cutting 90 degrees for light dragging/mixing 105 degrees for light material/grooming)
Frame	12 gauge side plates, 10 gauge rails, 2" square tow bar	12 gauge side plates, 10 gauge rails, 2" square tow bar
Actuator	Electric actuator w/ 4" Stroke	Electric actuator w/ 4" Stroke
Teeth Positions	Actuator raises and lowers Teeth from 4.5" above surface to 9/16" below	Actuator raises and lowers Teeth from 4.5" above surface to 9/16" below
Wheels	11" diameter x 4" wide x 5" rim	11" diameter x 4" wide x 5" rim
Hitch	Dual hitch system allows tow vehicle to use pin or ball hitches	Dual hitch system allows tow vehicle to use pin or ball hitches
Weight capacity (blocks)	80lbs (2 standard 16"x8"x8" cinder blocks)	80lbs (2 standard 16"x8"x8" cinder blocks)
Remote Control	Rocker switch tethered control – operator can adjust height of teeth from tow vehicle	Rocker switch tethered control – operator can adjust height of teeth from tow vehicle
Battery	12 volt 9Ah Battery with Charger	12 volt 9Ah Battery with Charger
Drag Screen	Optional drag screen	Optional drag screen
Minimum Tow Vehicle HP	Tow vehicle must be minimum of 14hp, 400 lb tractor or 350cc 4WD ATV- Max 24" hitch height	Tow vehicle must be minimum of 19hp, 500 lb tractor, or 500cc 4WD ATV
Dimensions	76" L X 49"W X 17" H	88" L X 60" W X 17" H
Weight	168LBS	175LBS

Main Parts (Figure 3 and Table below)

Item#	Description	Qty
1	Tow Bar	1
2	Pitch Bar	1
3	Tongue Bar	1
4	Ball Hitch	1
5	Axle	1
6	Wheel Assembly	2
7	Actuator Assembly	1
8	Parts Box (see Figure 4)	1
9	Battery Charger	1

Use Figure 3 and the list above to check the parts you received in the package. If you have any questions, please contact us at www.DRpower.com or call 1-800-DR-OWNER (376-9637) for assistance.

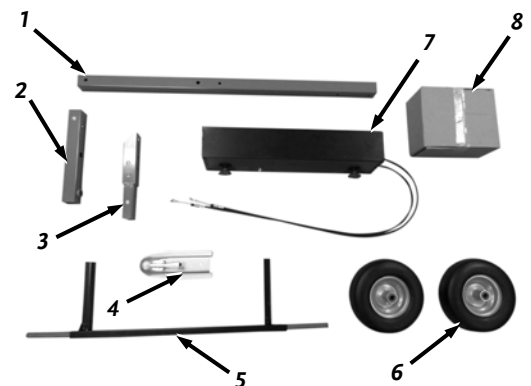

Figure 3

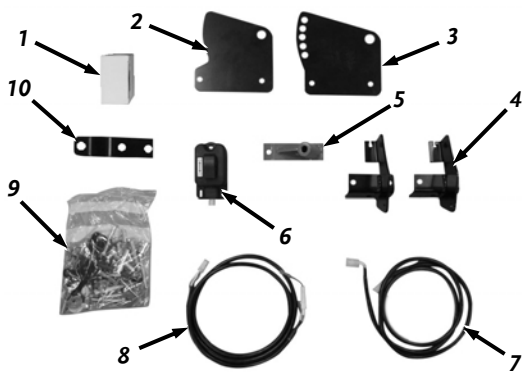

Figure 4

Parts Box (Figure 4 and Table below)

Description	Qty
1..... Battery Charger.....	1
2..... Pitch Plate.....	1
3..... Adjust Pitch Plate	1
4..... Axle Mounting Bracket.....	4
5..... Tooth Bar Bracket.....	1
6..... Control Box Assembly.....	1
7..... Extension Harness	1
8..... Actuator Harness	1
9..... Hardware Bag (see Figure 5)	1
10..... Strap, Pin Hitch	1

Use Figure 4 and the list above to check the parts you received in the package. If you have any questions, please contact us at www.DRpower.com or call 1-800-DR-OWNER (376-9637) for assistance.

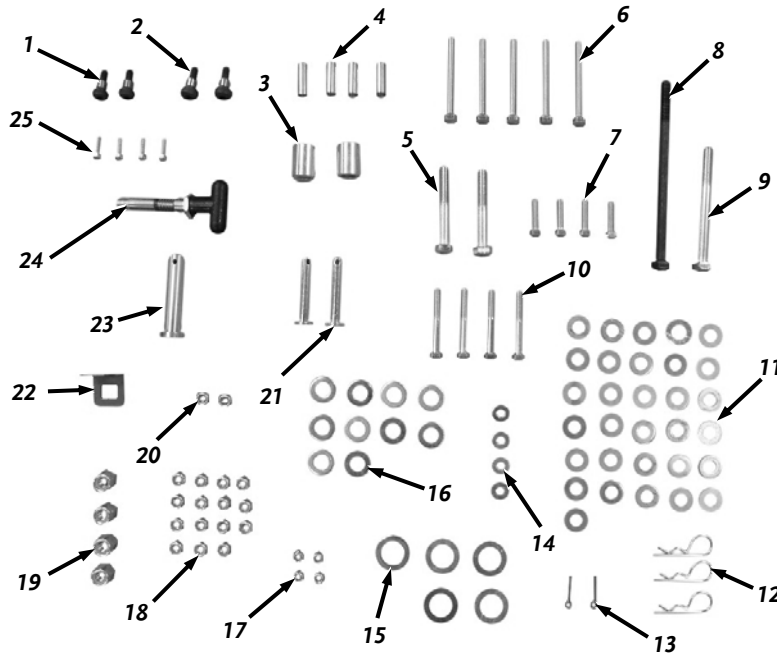

Figure 5

Hardware Bag (Figure 5 and Table below)

Index#	Part#	Description	Qty	Index#	Part#	Description	Qty
1	38720	Bolt, Shoulder, 10mm.....	2	14	11238	Washer, Flat, 1/4", USS.....	4
2	36737	Bolt Shoulder, 1/2 X 3/8, 3/8-16	2	15	18064	Washer, .81" ID X 1.5"OD X .11" L.....	5
3	37186	Spacer, Rail, Center.....	2	16	23499	Washer, Flat, 1/2", ZP	10
4	36702	Spacer, Rail.....	4	17	11073	Nut, Nylon Lock, 1/4-20	4
5	38911	Bolt, HCS, 1/2-13 X 3.25", GR5, ZP.....	2	18	16413	Nut, Nylon Lock, Low Profile, 3/8-16.....	15
6	11465	Bolt, HCS FT, 3/8-16 X 3", GR5, ZP	5	19	11072	Nut, Nylon Lock, 1/2-13	4
7	37239	Bolt, HHCS, 3/8-16 X 3/4", GR5, ZP....	4	20	38723	Nut, Nylon Lock, M8	2
8	38460	Bolt, HCS, 1/2-13 X 7", GR8	1	21	38475	Pin, Clevis.....	2
9	38461	Bolt, HCS, 1/2-13 X 4.5", GR8	1	22	38719	Mount, Molex	1
10	16484	Bolt, HHCS, 3/8-16 X 2-1/2", GR5, ZP. 4		23	38717	Pin, Pitch Bar	1
11	12170	Washer, Flat, 3/8", SAE.....	30	24	38469	Pull Pin, Assembly	1
12	38718	Hairpin, Cotter Pin.....	3	25	15730	Bolt, HCS, 1/4-20 X 3/4", GR5	4
13	37190	Pin, Cotter, 3/32 X 1", ZP	2				

Use Figure 5 and the list above to check the parts you received in the package. If you have any questions, please contact us at www.DRpower.com or call 1-800-DR-OWNER (376-9637) for assistance.

Tools Needed

- Two 9/16" Wrenches
- Two 3/4" Wrenches
- 7/8" Wrench
- 1/4" Allen Wrench
- Needle Nose Pliers
- 7/16" Wrench
- Ratchet, Extension and 7/16" Socket
- Two 1/2" Wrenches
- Wire Cutters
- 13mm Wrench
- 5mm Allen Wrench

Assembly

1. Position the Power Grader Frame on a clean flat surface with the Weight Box Straps on top (**Figure 6**).

Note: The Weight Box Straps are secured at the ends but not at the center of the machine. You may need to loosen the hardware at the ends before performing the next step.

2. Rotate the Weight Box Straps to align with the mounting holes in the front Crossmember. Secure each Strap with a 3/8-16 X 2-1/2" Bolt, 3/8" Flat Washer, Rail Spacer (inside Crossmember), 3/8" Flat Washer and a Locknut using two 9/16" Wrenches. Tighten hardware on the other end of the Weight Box Straps.

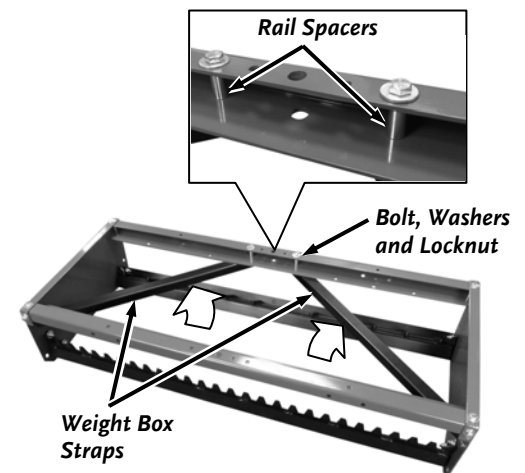

Figure 6

3. Position the Frame Assembly, with the front facing up, to gain access to the Tooth Bar area (**Figure 7**).
4. Support the Tooth Bar as you remove the four Bolts, Flat Washers and Locknuts that are securing the Tooth Bar using two 9/16" Wrenches.
5. Turn the Tooth Bar around and flip end to end so the teeth are facing forward. Secure the Tooth Bar with the Bolts, Flat Washers and Locknuts but do not fully tighten at this time.

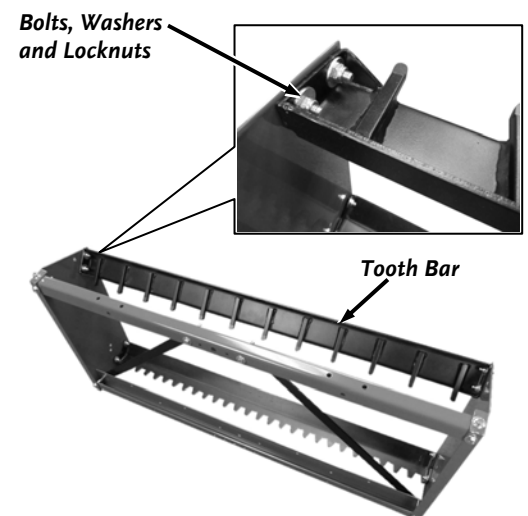

Figure 7

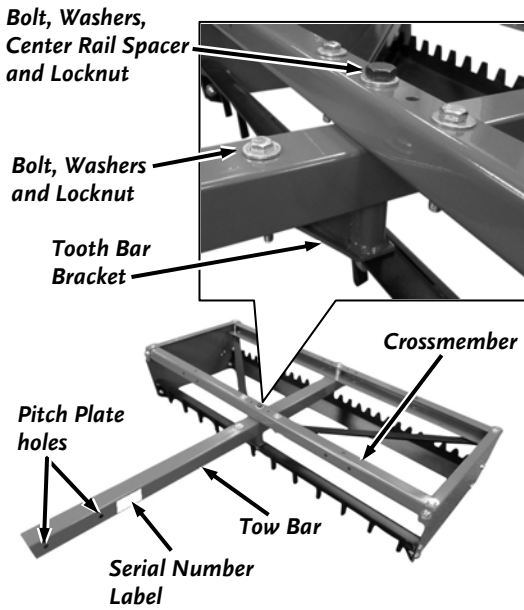

Figure 8

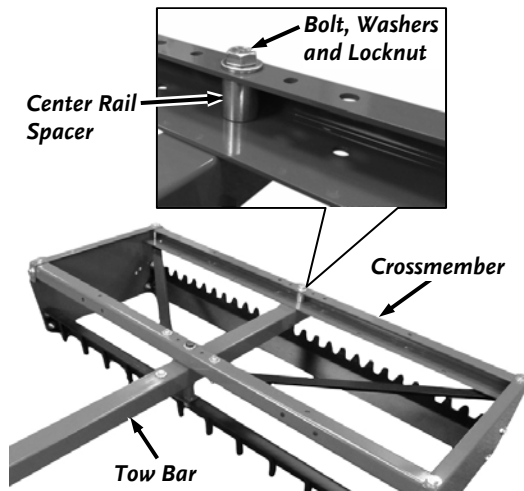

Figure 9

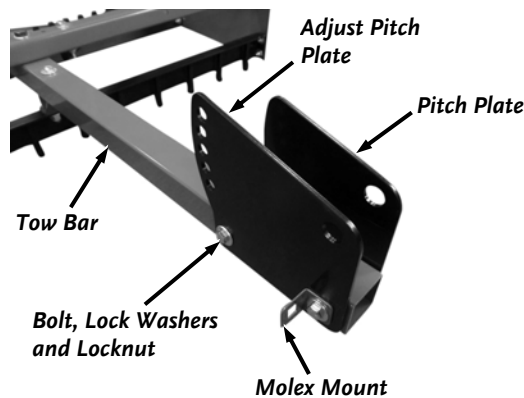

Figure 10

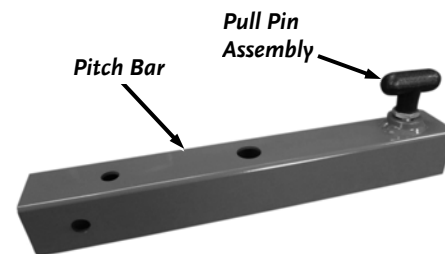

Figure 11

6. Position the Frame Assembly with the front facing forward and both Crossmembers on top (**Figure 8**).
 7. Position the Tow Bar under the Crossmembers with the two Pitch Plate mounting holes and Serial Number Label toward the front.
 8. Insert the Tooth Bar Bracket between the front Crossmember and Tooth Bar.
 9. Secure the Tow Bar to the front Crossmember with a 1/2-13 X 7" Bolt, 1/2" Flat Washer, Center Rail Spacer (inserted into Crossmember), 1/2" Flat Washer and 1/2" Locknut. Only hand tight for now.
 10. Secure the Tow Bar to the front of the Tooth bar Bracket to the with a 3/8-16 X 3" Bolt, 3/8" Washer (against Crossmember), 3/8" Washer (against Tooth Bar Bracket) and Locknut.
 11. Secure the rear of the Tow Bar (**Figure 9**) with a 1/2-13 X 4.5" Bolt, 1/2" Washer, Center Rail Spacer (inserted into Crossmember), 1/2" Washer and 1/2" Locknut. Tighten with two 3/4" Wrenches.
 12. Tighten the Hardware you installed in step 9 with Two 3/4" Wrenches.
 13. Tighten the Hardware you installed in step 10 with Two 9/16" Wrenches.
- Note:** The 1/2" Bolt and Locknut that you tightened in step 9 and 11 should be very tight so the parts are compressed together for strength.
14. Tighten the Hardware you installed in step 5 with Two 9/16" Wrenches.
 15. Position the Pitch Plate (left side) and Adjust Pitch Plate (right side) (**Figure 10**) and install a 3/8-16 X 3" Bolt, 3/8" Washer (Bolt side), 3/8" Washer (Locknut side) and 3/8" Locknut at the rear using two 9/16" Wrenches.
 16. Install a 3/8-16 X 3" Bolt, 3/8" Washer (Bolt side), Molex Mount, 3/8" Washer (Locknut side) and 3/8" Locknut at the front using two 9/16" Wrenches.
- Note:** Ensure the Molex Mount is oriented as shown in Figure 10.
17. Install the Pull Pin Assembly into the Pitch Bar using a 7/8" Wrench (**Figure 11**)

18. Position the Pitch Bar between the Pitch Plates and secure with the Pitch Bar Pin, .81" ID X 1.5"OD X .11" Washer and Hair Pin Cotter Pin (**Figure 12**).

Note: The Pull Pin Assembly will need to be pulled out to position the Pitch Bar between the Pitch Plates.

19. Insert the Tongue Bar into the Pitch Bar and secure with the Clevis Pin, 1/2" Washer and Hairpin Cotter Pin (**Figure 13**).

20. PIN HITCH INSTALL:

Note: Position the Hitch Clevis Pin into the Pin Hitch Strap and Tongue Bar to align parts for the next step.

- a) Install the Pin Hitch Strap onto the Tongue Bar with two 3/8-16 X 3" Bolts, 3/8" Washers (Bolt Side), 3/8" Washers (Locknut side) and 3/8" Locknuts using two 9/16" Wrenches.
- b) Install a 1/2" Washer and Hairpin Cotter Pin to secure the Hitch Clevis Pin.

BALL HITCH INSTALL:

- a) Install the Ball Hitch onto the Tongue Bar with two 1/2-13 X 3.25" Bolts, 1/2" Washers (Bolt Side), 1/2" Washers (Locknut side) and 1/2" Locknuts using two 3/4" Wrenches (**Figure 14**).
- b) Install a 1/2" Washer and Hairpin Cotter Pin to secure the Hitch Clevis Pin.

21. Secure the top of a Axle Mounting Bracket onto the rear Crossmember with a 3/8-16 X 2-1/2" Bolt, 3/8" Washer (Bolt side), Rail Spacer (inside Crossmember) 3/8" Washer (locknut side) and 3/8" Locknut using two 9/16" Wrenches (**Figure 15**).

22. Secure the rear of the Axle Mounting Bracket to the Crossmember with 3/8-16 X 3/4" Bolts, 3/8" Washers (Bolt side), 3/8" Washers (locknut side) and 3/8" Locknut using two 9/16" Wrenches.

23. Install the second Axle Mounting Bracket as described in the last step.

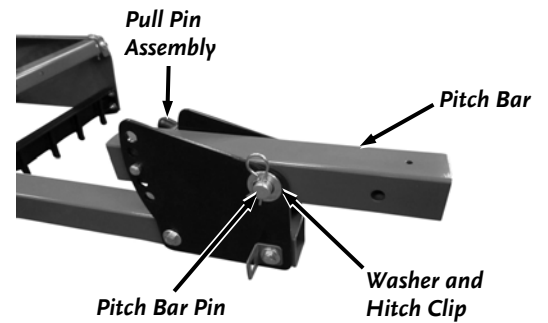

Figure 12

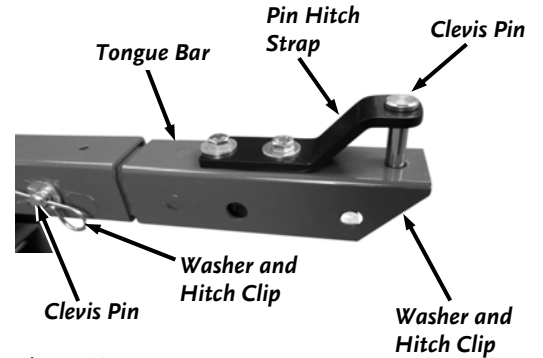

Figure 13

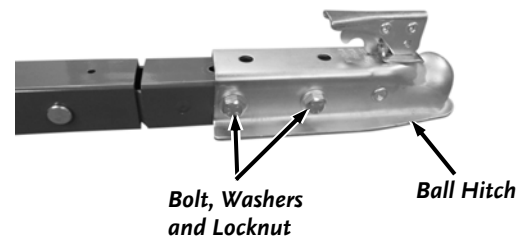

Figure 14

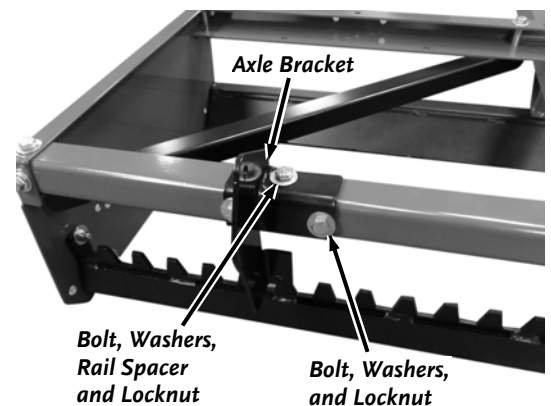

Figure 15

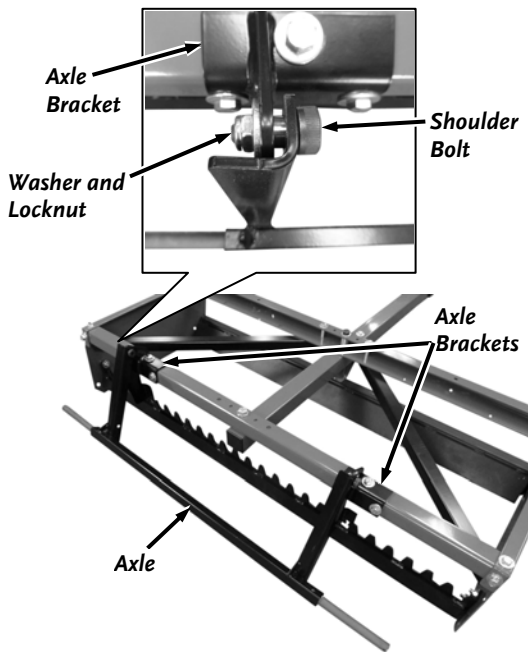

Figure 16

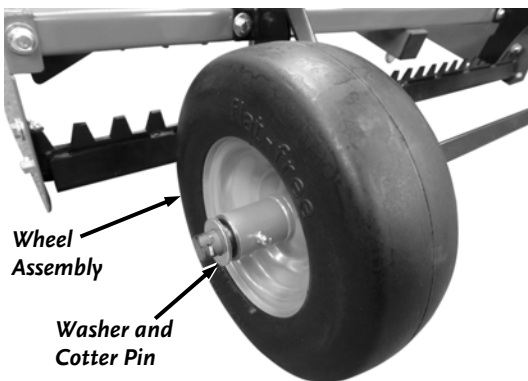

Figure 17

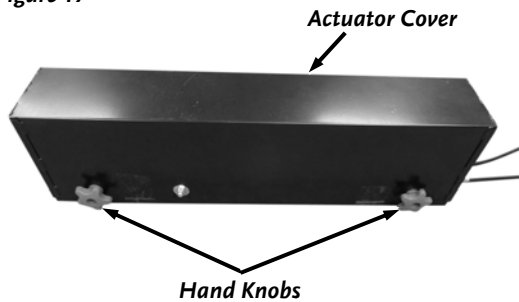

Figure 18

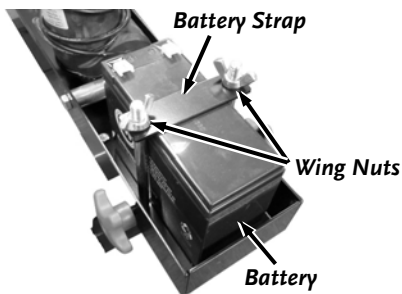

Figure 19

24. Install the Axle to both Axle Brackets with a 1/2 X 3/8L, 3/8-16 Shoulder Bolt, 3/8" Washer (Locknut Side) and 3/8" Locknut using a 4mm Allen Wrench on the Bolt and 9/16" Wrench on the Locknut (**Figure 16**).

Note: Ensure that the Axle Weldment and Hardware is oriented as shown with the Bolt and Axle Arm on the right side of the Bracket.

25. Install a .81" ID X 1.5"OD X .11" L Washer onto one end of the Axle, followed by a Wheel Assembly (Grease Fitting facing out) (**Figure 17**).
26. Secure the Wheel Assembly with another .81" ID X 1.5"OD X .11" L Washer and 3/32 X 1" Cotter Pin. Use Needle Nose Pliers to bend the Cotter pin ends over.
27. Install a Wheel Assembly on the other end of the Axle as described above.
28. Loosen the Hand Knobs securing the Actuator Cover and remove the Cover.
29. Remove the Wing Nuts and lift the Battery Strap and Battery out of the Actuator Assembly (**Figure 19**).
30. Position the Actuator Assembly onto the Frame Crossmembers with the Cables towards the front (**Figure 20**).
31. Position the large holes in the Actuator Assembly over the large Crossmember Bolts. Align the four mounting holes of the Actuator Assembly.

Note: Insert the Bolts from the bottom (Crossmember side) in the next step.

32. Secure the Actuator Assembly to the Crossmembers with four 1/4-20 X 3/4" Bolts, 1/4" Washers (one on Bolt side and one on Locknut side) and 1/4" Locknuts using a 7/16" Wrench and a 7/16" Socket with Ratchet and Extension.
33. Reinstall the Battery with the Battery Strap and Wing Nuts.

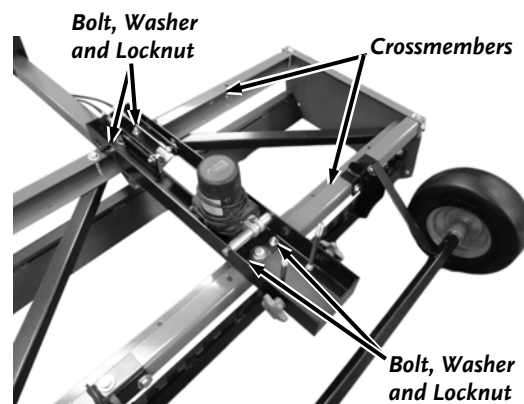

Figure 20

34. Route the Height Adjust Cables back under the Crossmembers towards the rear of the Frame. Ensure the Cables are on top of the Tooth Bar and Mold Board (**Figure 21**).
35. Pull the Rubber Boot off the threads of the both Height Adjust Cables and unscrew the outer Nut off the threads (**Figure 22**).
36. Ensure the inner Nut on each Cable is screwed onto the threads as far as it will go.
37. Slide the Cables into the slots of the Axle Brackets and pull the threads through the hole (**Figure 23**).
38. Install the outer Nuts and screw all the way on. Hold the inner Nut as you tighten the outer nut using two 1/2" Wrenches on both Cables (**Figure 24**).
39. Slide the Rubber Boots onto the threads.
40. Insert the 10mm Shoulder Bolts through the Cable Eyelets and into the hole of the Axle Weldment (**Figure 25**).
41. Secure the Bolts with 3/8" Washers and M8 Locknuts using a 5mm Allen Wrench for the Locknut and a 13mm Wrench.
42. Use the holes through the front Crossmember to secure the Height Adjust Cables with Cable Ties (**Figure 26**).

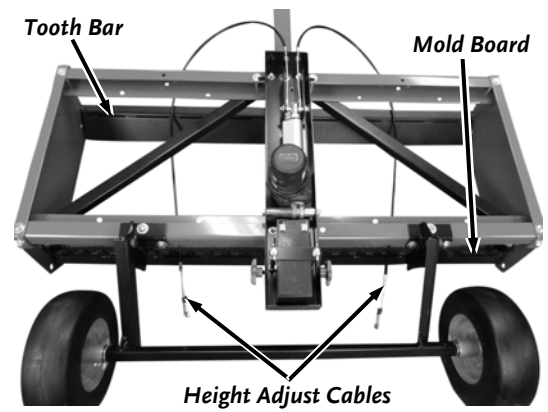

Figure 21

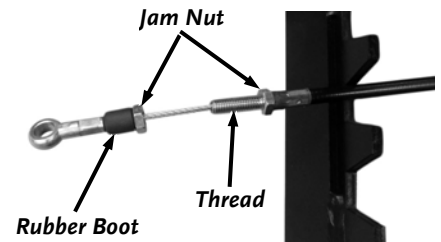

Figure 22

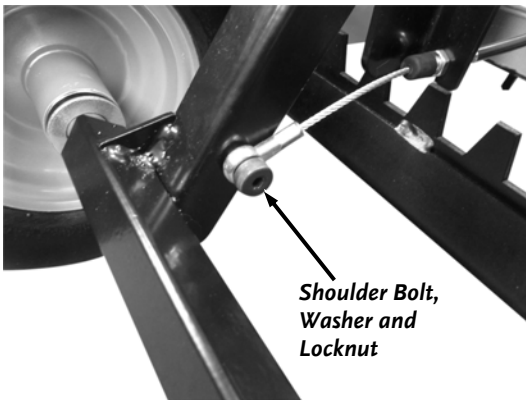

Figure 25

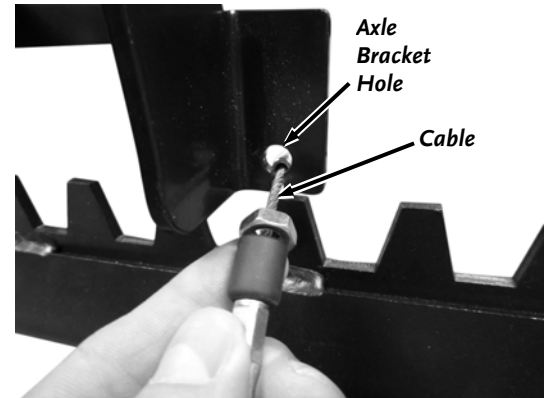

Figure 23

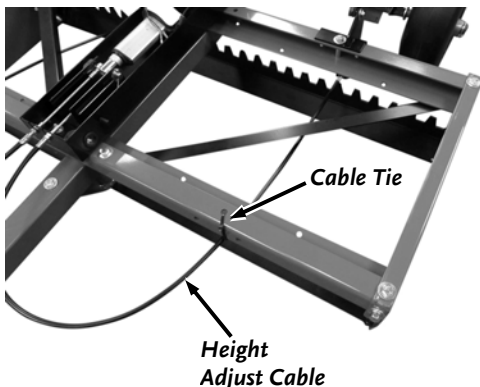

Figure 26

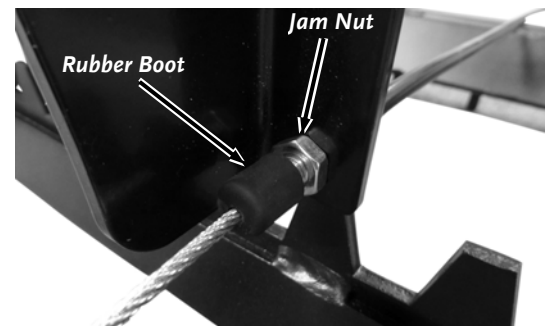

Figure 24

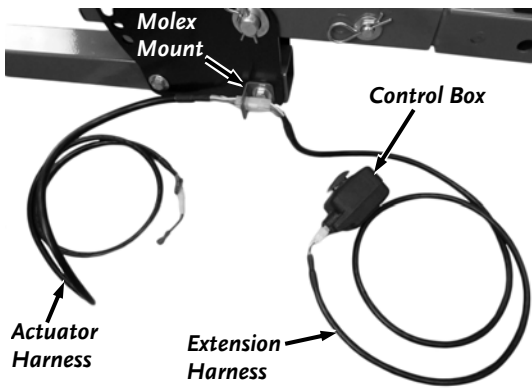

Figure 27

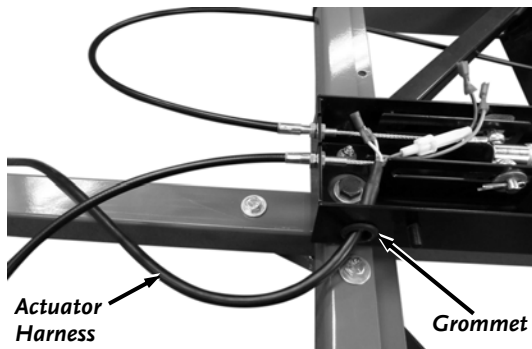

Figure 28

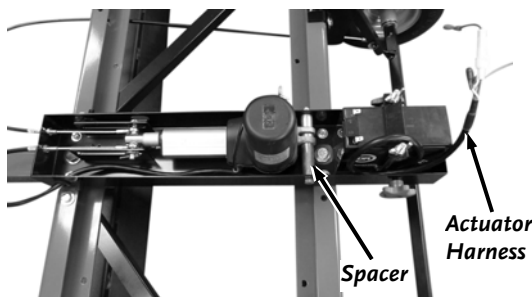

Figure 29

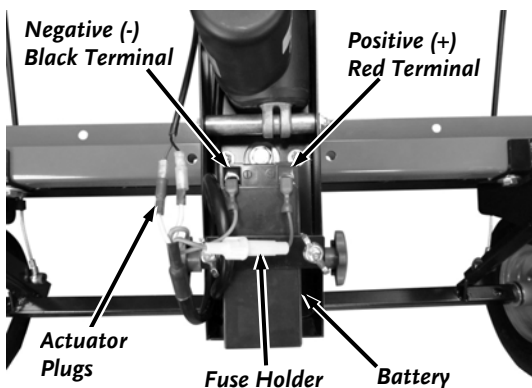

Figure 30

43. Insert the Connector of the Actuator Harness into the Molex Mount and push to snap in place (**Figure 27**).
44. Plug the Extension Harness into the Actuator Harness at the Molex Mount.
45. Plug the Extension Harness into the Control Box.
46. Route the Actuator Harness over the Tow Bar to the left side of the machine (make sure the Harness stays under the Height Adjust Cable (**Figure 28**)).
47. Insert the end of the Actuator Harness through the Grommet on the left side of the Actuator Assembly.
48. Route the Actuator Harness along the left side of the Actuator and under the Spacer (**Figure 29**).
49. Continue routing the Harness until there is no slack at the Tow Bar.
50. Connect the two Actuator Plugs to the Harness (**Figure 30**).
51. Connect the Red Positive (+) Harness Wire (with Fuse Holder) to the Red terminal on the Battery.
52. Connect the Black Negative (-) Harness Wire to the Black terminal on the Battery.
53. Tuck the Actuator harness in next to the Battery to keep it out of the way when the Cover is installed.
54. Use the remaining Cable Ties to secure the Harnesses to the Tow Bar and Pitch Bar (**Figure 31**).
55. Reinstall the Battery with the Battery Strap and Wing Nuts.
56. Replace the Actuator Cover and tighten the Hand Knobs to secure (**Figure 32**).

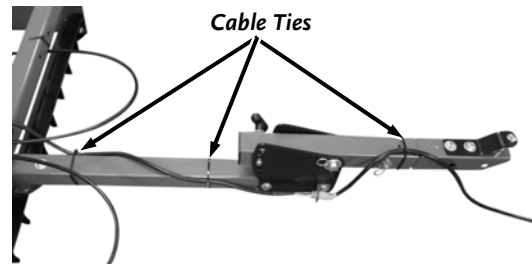

Figure 31

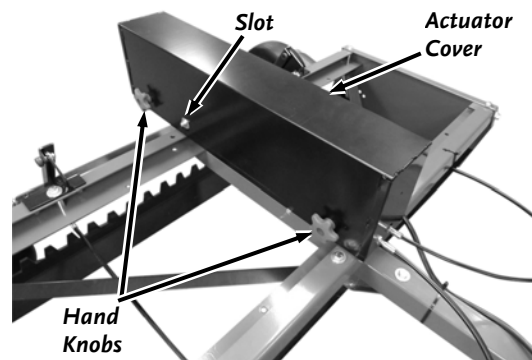

Figure 32

Connecting the DR POWER GRADER to your Tow Vehicle

The following procedure is for connecting the DR POWER GRADER to your Tow Bar (Tractor) or Ball Hitch (ATV) configuration.

You should start out with the Frame of the Power Grader level to observe the performance of the grader before making any adjustments. If the Tow Bar Hitch is not at the proper height to keep the Frame of the Power Grader Level, refer to “Adjusting the Power Grader for Grading and Scarifying” on page 18 to adjust the Tow Bar Height.

Lawn Tractor: (Tow Bar Hitch)

1. Stop the Lawn Tractor Engine and set the Parking Brake.
2. Lift the Tow Bar and position the Tow Bar Hitch opening onto the Lawn Tractor Hitch Plate (**Figure 33**).
3. Align the hole in the center of the Hitch Plate on your Lawn Tractor with the holes in the Tow Bar Hitch. Insert the Clevis Pin and secure it with the 1/2" Washer and Hairpin.

ATV: (Tow Ball Hitch)

1. Stop the ATV engine, put the transmission in 1st gear and set the Parking Brake on your ATV
2. Pull the Latch Assembly up and into the open position. Position the Ball Hitch onto the tow vehicle's tow ball (must be a 2" tow ball) (**Figure 34**).
3. Close the Latch Assembly to lock it onto the Tow Ball.

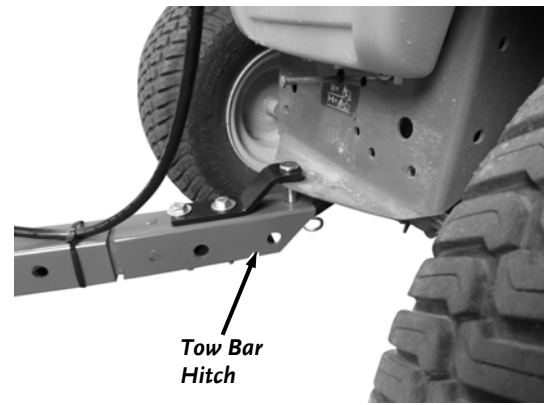

Figure 33

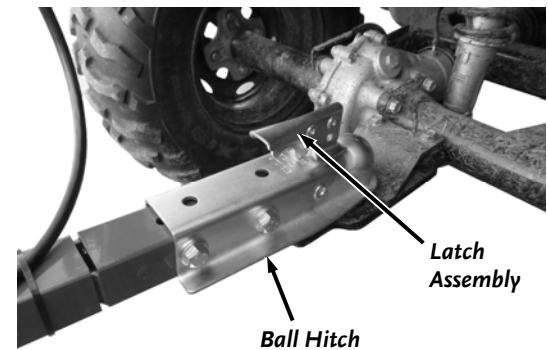

Figure 34

About the Battery

The DR POWER GRADER comes with a 12-Volt, maintenance-free, rechargeable, sealed lead acid Battery. Properly maintained and charged, the battery provides years of dependable service.

! WARNING

- Never modify your GRADER'S electrical system. Modifications could ruin the electrical system as well as cause a fire, resulting in serious injury.
- Using electrical components other than those supplied with your GRADER could cause the electrical system to overheat, explode, or start a fire.
- Only adults should handle the battery, it contains sulfuric acid (an electrolyte). The battery is heavy; dropping it could result in serious injury.
- Never lift or carry the battery by the cables or terminals. This can damage the battery and possibly start a fire, resulting in serious injury. Lift and carry the battery only by its case.
- Do not short circuit the battery.
- Read the safety instructions on the battery.

Charging the Battery

! WARNING

- Using the wrong type of battery or charger could cause a fire or explosion, resulting in serious injury.
- Never allow children to charge the battery. THE ELECTRICITY INVOLVED IN CHARGING THE BATTERY COULD INJURE A CHILD.
- Examine the charger, its connectors, and the battery for excessive wear or damage each time you charge the battery. If you see any excessive wear or damage, do not use the charger or the battery, replace them.
- Use only the 12-volt charger supplied with your grader to charge the battery.
- Use the charger only in dry locations. Avoid contact with water.

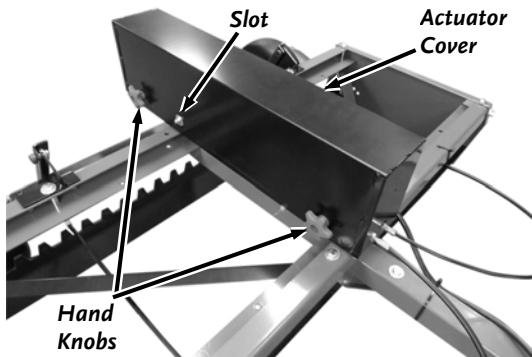

Figure 35

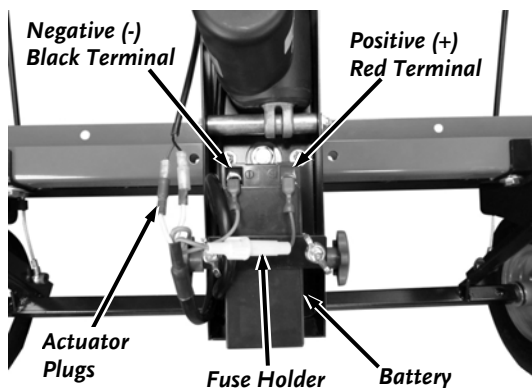

Figure 36

Charging the Battery is a simple process. Remove the Battery from your DR POWER GRADER when you charge it.

1. Loosen the Hand Knobs and remove the Actuator Cover.
 2. Disconnect the Positive (red) and Negative (black) Terminals from the Battery.
 3. Remove the Thumb Screws and Battery Strap.
 4. Remove the Battery from your DR POWER GRADER
 5. Recharge the Battery in a dry location where the temperature is between 32°F and 78°F. For a fully discharged Battery, allow 24-48 hours to recharge.
 6. Attach the Black (-) Terminal wire from the Charger Adapter to the (-) Spade of the Battery, then attach the Red (+) Terminal wire to the (+) Battery Spade.
 7. Plug the Charger into a standard wall outlet.
- Every time you finish using your DR POWER GRADER, recharge the Battery. The time it takes to recharge the Battery depends on how drained it is when you start. Charging the Battery typically takes 6 to 8 hours if charged after each use. However, charging may take 24 to 48 hours if you allow the Battery to run down before it is charged. The Battery does not have a “memory” so don’t worry about overcharging the Battery or charging it too often.
 - You can charge the Battery hundreds of times. The Battery lasts longer if you charge it before it is fully drained. Keep it fully charged and at room temperature when not using your DR POWER GRADER.
 - Once the Battery is charged, pull the plug from the wall outlet and then remove the Charger from your Battery. Re-connect the Positive and Negative Terminals to the Battery for use.

- Store the Charger in the Box it was shipped in. Keep the charger in a dry location.
- If the Battery does not hold its charge for very long under normal conditions or it simply won’t hold a charge, then replace it. You can purchase a replacement Battery directly from us. To install your new Battery, remove the Battery Clamp, detach the cables and remove the dead Battery, next install the new Battery and attach the cables, then replace the Battery Clamp.

NOTICE

When the Battery gets old and no longer accepts a charge, remove it from your Grader. Never leave a dead Battery in your Grader. Dispose of an old Battery per local hazardous materials regulations. Please refer to “recycling a used battery”, on page 22, for more information.

Chapter 3: Operating the DR POWER GRADER

It may be helpful to better familiarize yourself with the features of your Grader by reviewing **Figure 2** in Chapter 2 before beginning the steps outlined in this chapter.

Operating Safety

WARNING

- Never allow anyone to operate the DR Power Grader without first reading and understanding all instructions in this manual. Be thoroughly familiar with the controls and the proper use of your Grader before using.
 - Never let people ride on the Grader.
 - **Always check for objects in the Grader's path before moving.**
 - When operating in a roadway, we suggest that you put out obstructions (marker cones or pails) to divert any traffic away from your work area. Always be aware of potential traffic hazards.
-

Operating Parameters

There are four different types of tow vehicles recommended for the DR POWER GRADER. Each vehicle type has specific strengths, weaknesses, and operating parameters when used with the DR POWER GRADER.

- **Garden Tractor/Lawn Tractor**
 - 14 HP and/or 400-pound tractor minimum for the 48" Model.
 - 19 HP and/or 500-pound tractor minimum for the 60" Model.
 - 5° slopes or less.
 - Material loosened during grading increases traction difficulties.
 - Very good speed control and turning radius.
 - Frequent Scarifying Teeth adjustment may be necessary to maintain traction
 - Forward motion of the DR POWER GRADER may need to be initiated before ground contact.
- **ATV**
 - Traction issues are less evident.
 - More difficult to maintain a consistent speed of less than 5 MPH.
 - Turning radius is large (best used for large, straight drives).
- **UTV**
 - Traction issues are less evident.
 - More difficult to maintain a consistent speed of less than 5 MPH.
 - Turning radius is large (best used for large, straight drives).
 - The tailgate should be lowered for best visibility.
- **Utility Tractor**
 - Traction is excellent.
 - Visibility is very good.
 - With the increased power, the chance of accidentally damaging the DR POWER GRADER's frame is increased. The towing speed **MUST** be kept less than 5 MPH.
- **Not for use with Truck or Car**
 - Do not use these types of vehicles; the DR POWER GRADER is difficult to see.
 - **NEVER** operate the DR POWER GRADER with a Truck (2WD or 4WD). Use of a Truck or Car will void the DR POWER GRADER Warranty.

Operating Tips

! CAUTION

Lower the grader frame completely to the ground surface when transporting on a trailer, parking on a hill, or servicing the grader.

- Use additional weight (up to 80 pounds) by placing two Cinder Blocks between the Crossmembers when grading hard pack to begin scarification. A Weight Strap kit is needed to properly mount Cinder Blocks to the Grader. Call toll-free 1-800-DR-OWNER (376-9637) to order a Weight Strap Kit.
- Remove any added weight such as Cinder Blocks when the surface material loosens or when experiencing traction difficulties.
- To create a smoother surface in soft materials, use the Drag Screen Accessory available from DR Power Equipment.
- Remove the weights when grading in muddy conditions or sandy soil.
- Expect to make several passes with the DR POWER GRADER to repair a roadway, depending on the condition.
- Avoid filling Pot Holes filled with water, wait until the holes are dry.
- Use the DR POWER GRADER to work the edges of Pot Holes that are more than 4 feet wide to loosen the sides before you begin filling them.
- Avoid large rocks, embedded ledge, cattle guards, or similar obstructions.
- Remove rocks pulled to the surface during grading to provide a better final graded surface.
 - The rocks can catch under the lawn deck (lawn tractors).
- Once you have adequately scarified the road surface, raise the Scarifying Teeth Plate to allow the Rear Scraper (mold) Blade to create a smooth surface.
 - Raise the Tooth Bar Plate out of the ground before turning around or leaving the work area.
- When using a lawn tractor as the tow vehicle, put the lawn mowing deck in the highest setting or just remove the deck to obtain the highest ground clearance.
 - For ease, do your spring grading before re-installing your lawn deck for the summer mowing activity.
- When using the DR POWER GRADER to prepare a seed bed, remove all large debris before grading.
 - Use the Optional Drag Screen to create the best finish in sand or to incorporate seed.
- Use Low Gear when using an ATV as the tow vehicle – Do not exceed 5 MPH while grading.
 - The maximum speed when not grading is 10 MPH.

NOTICE

Frequently check the tightness of the bolts that fasten the Tooth Bar and Mold Board to the frame.

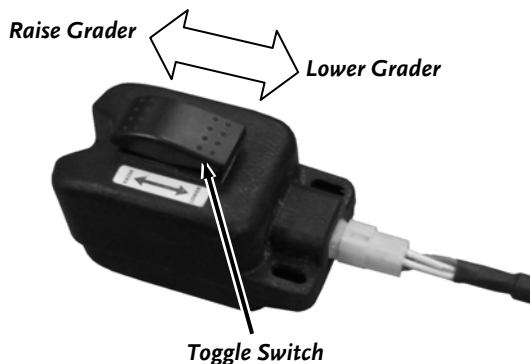

Figure 37

FAQs

Question: Can the DR POWER GRADER create a crown in the road?

Answer: No, but you can maintain a crown in the road by grading each side separately.

Question: Can the DR POWER GRADER ruin the crown in the road?

Answer: Yes, but only if you grade down the centerline of the road.

Question: Can I use my Lawn Tractor in sandy soils?

Answer: Lawn Tractors do not perform as well as an ATV or Utility Tractor in sandy soils.

Adjusting the Power Grader for Grading and Scarifying

1. Push the Button on the Control Box at the "LOWER" position to lower the Grader fully on the ground (**Figure 37**).

2. Changing Pin Hitch positions:

- Remove the Connectors from the Molex Mount (**Figure 38**).
- Remove the Bolt, Washers and Locknut at the rear of the Pitch Plates using two 9/16" Wrenches.
- Remove the Bolt, Molex Mount, Washers and Locknut at the front of the Pitch Plates.
- Flip the Pitch Plate Assembly over and reinstall the Bolts, Washers, Molex Mount, and Locknuts (**Figure 39**).

3. Adjust the Pin Hitch Assembly as described below:

- Position the Tow Bar to the highest position (on top) for low Hitch aggressive grading (**Figure 39**). See "Adjusting the Mold Board" for other Mold Board settings
- Position the Tow Bar to the lowest position (on bottom) for tall hitch aggressive scarifying (**Figure 38**).
- Use the remaining Tow Bar Hitch mounting positions for varying degrees of Grading and Scarifying.

Using the Mold Board

ADJUSTING THE ANGLE:

The Mold Board angle can be set at three different angles to determine how aggressively it moves and molds the material.

Tools Needed:

- Two 9/16" Wrenches
- Remove the top Bolt and Locknut on both ends of the Mold Board using two 9/16" Wrenches (**Figure 40**).
 - Loosen the Bottom Bolt and Locknut using two 9/16" Wrenches so the Mold Board can be rotated.
 - Rotate the Mold Board to align with the holes at the desired setting.
 - Reinstall the top Bolts and locknuts and tighten all hardware.

CONVERTING TO SMOOTH OR GROOVED EDGE:

The Mold Board can be mounted with the straight edge down for basic grading or for creating smoother surfaces in finer materials. It can also be mounted with the grooved edge down for more aggressive grading or for creating grooved surfaces in finer materials.

Tools Needed:

- Two 9/16" Wrenches
- Remove the Bolts and Locknuts securing both ends of the Mold Board to the Power Grader Frame using two 9/16" Wrenches (**Figure 41**).

Note: The Mold Board must always be positioned with the welded angle facing toward the rear (**Figure 42**).

- Remove the Mold Board and position it with the desired edge down and the welded Angle facing the rear of the machine.
- Reinstall the Mold Board and secure with the Bolts and Locknuts.

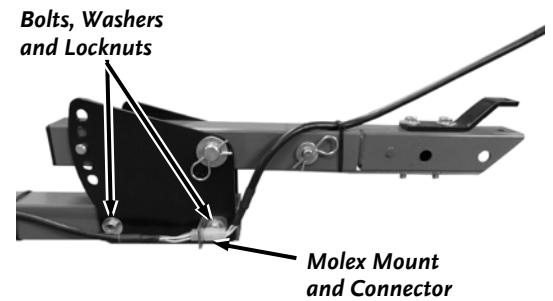

Figure 38

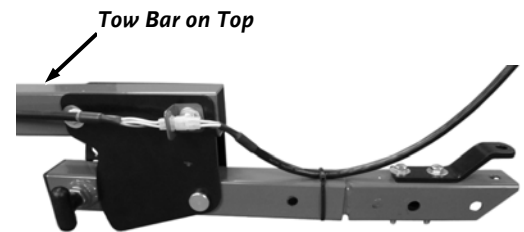

Figure 39

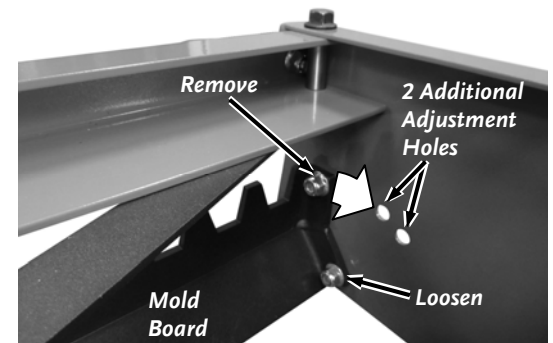

Figure 40

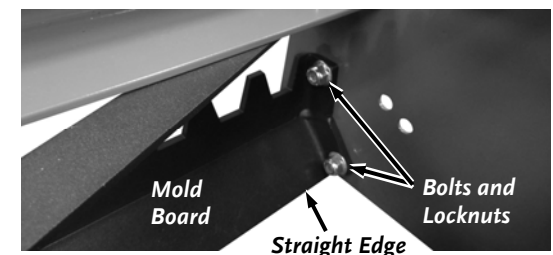

Figure 41

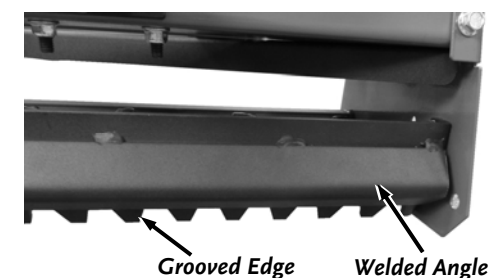

Figure 42

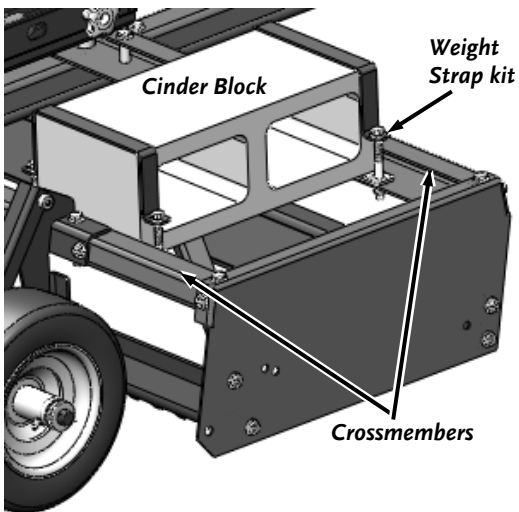

Figure 43

Adding Weight to the Weight Tray

NOTICE

- Do not add more than 80 pounds of weight to the Grader. More than 80 pounds could cause damage to the Grader and void the Warranty.
- A weight strap kit is needed to adequately secure weight blocks added to the Grader

Two Concrete Blocks can be placed between the Crossmembers to add more weight for harder surfaces (**Figure 43**).

Blocks added to the top of the Grader should be strapped to the Crossmembers using the Weight Strap Kit accessory. If you don't use the Weight Strap Kit your Grader could be damaged and void the Warranty. Contact us at www.DRpower.com to purchase the Weight Strap Kit.

Note: The Weight Strap Kit is designed to use 4" or 6" tall Concrete Blocks.

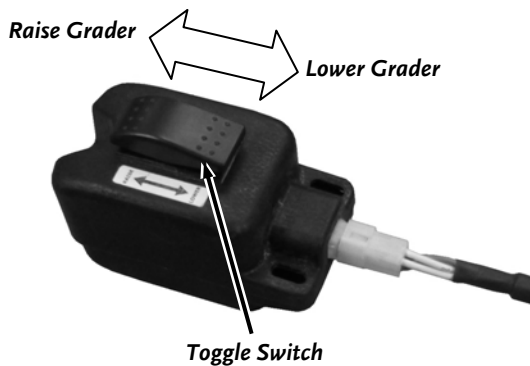

Figure 44

Raising the Grader for transporting

1. Push the Button on the Control Box at the "RAISE" position to lift the Grader fully off ground (**Figure 44**).

Optional Drag Screen - Kit No. 21086 (48" Model) and 22686 (60" Model)

An optional Drag Screen is available for your DR POWER GRADER. This heavy-duty, flexible-steel screen attaches easily behind the DR POWER GRADER to break up and smooth any clumps that form as you grade the material.

The Drag Screen is also designed to produce a more highly finished surface when using fine dry materials such as sand and to remove the small lines or ridges sometimes left by the Scarifying Teeth or Grader Wheels during the initial grading process. The Drag Screen is ideal for areas that have high sand or soil content such as new lawns, riding rinks, ball fields, or sandy driveways.

The Drag Screen is also very helpful in seeding large areas. By lifting the Scarifying Teeth and Mold Board of the DR POWER GRADER above the working surface so that only the wheels make contact, the Drag Screen simply and effectively distributes the topsoil uniformly over the seed.

For more information and to order the Optional Drag Screen for your new DR POWER GRADER, contact us at www.DRpower.com or call Toll-Free 1-800-DR-OWNER (376-9637).

Chapter 4: Maintaining The DR POWER GRADER

Regular maintenance is the way to ensure the best performance and long life of your machine. Please refer to this Chapter for maintenance intervals and procedures.

WARNING

Before performing any maintenance, you must first shut off the tow vehicle, remove the key and set the parking brake.

Regular Maintenance Checklist

PROCEDURE	BEFORE EACH USE	AFTER EACH USE	EVERY 25 HOURS
Check tightness of Tooth Bar and Mold Board Hardware	▲		
Check general equipment condition e.g., Nuts, Bolts, welds, etc.	▲		
Check Actuator operation/Battery Power	▲		
Hose down the DR POWER GRADER		▲	
Lubricate Wheels as needed			▲

Cleaning the Power Grader

NOTICE

- Use care not to hose down the Battery and electrical components.
- Ensure the Actuator Cover is installed before using a Hose or power washer.

1. Use a Hose or Power Washer to clean the DR POWER GRADER to keep the Scarifying Teeth Plate, Wheels etc. clean and clear of debris.

Caring for the Battery

Proper care can lengthen the life of a Battery. Follow these recommendations to ensure your Battery's best performance and long life:

- Do not continue to operate your DR POWER GRADER with a low Battery.
- Try to keep your Battery at full charge to maximize its life. If the machine is not used, charge the Battery monthly. See "Charging the Battery" on page 16.
- Before charging the Battery, observe its external appearance and keep it clean and dry. Never charge or use a Battery that shows cracks, changes shape, leaks, or otherwise obviously damaged.
- Recharge a Battery before fully discharged. **NEVER allow the Battery to run down completely before charging. Leaving the Battery discharged damages the Battery.** Charge the Battery at least once per month, even if you have not used your DR POWER GRADER.
- If the Battery begins to leak, avoid contact with the leaking acid. Place the damaged Battery in a plastic bag, then dispose of it properly. Please refer to "recycling a used battery" on page 22 for more information.

WARNING

If Battery Acid does contact your skin or eyes, flush with cool water for at least 15 minutes and call a physician. If Acid is ingested, call a physician immediately.

Recycling a Used Battery

NOTICE

Please dispose of used batteries responsibly, according to your local hazardous materials regulations. Never throw away used batteries in your household trash.

Please dispose of your used Batteries responsibly by recycling them. Call your local Solid Waste Management District or your local waste handler to locate the collection site nearest you. Some collection sites recycle Batteries year-round; others collect them periodically.

You can also visit the Website of Earth 911 for more information (www.earth911.org). Once there, click Recycle Guide at the top of the page, then click the Municipal HHW link under Hazardous Household Waste, and enter your zip code. The site lists recycling centers located near you.

For a fee, you can recycle your Batteries with the International Metals Reclamation Company. Visit them at www.inmetco.com and click Services, then click Battery Recycling; or contact them at: INMETCO, One INMETCO Drive, Ellwood City, PA 16117, (724) 758-5515; fax (724) 758-2845.

To learn more about hazardous waste recycling, visit the Website for Battery Council International (www.batterycouncil.org) or for the Environmental Protection Agency (www.epa.gov).

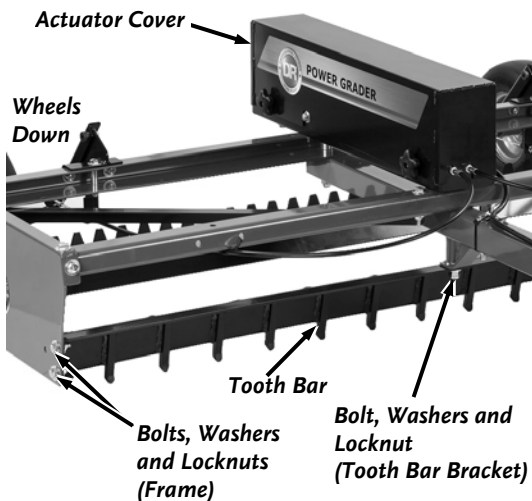

Figure 46

Replacing the Tooth Bar

Tools Needed:

- Two 9/16" Wrenches
- 3/4" Wrench
- 3/4" Socket with ratchet and Extension

1. Use the Control Box to raise the DR POWER GRADER off the ground.
2. Remove the Bolts and Locknuts on both ends of the Tooth Bar using two 9/16" Wrenches (**Figure 46**).
3. Loosen the Hand Knobs and remove the Actuator Cover.
4. Remove the Bolt, Washers and Locknut at the Tooth Bar Bracket using a 3/4" Wrench and 3/4" Socket with Ratchet and Extension.
5. Remove the old Tooth Bar and clean the mounting area of the Frame.
6. Position the new Tooth Bar and secure with the Bolts, Washers and Locknuts removed in steps 2 and 4.
7. Install the Actuator Cover.

Lubrication

Tools and Supplies Needed:

- Flexible hose grease gun
- Lithium grease
- Clean Rags

1. Clean the Grease Fitting with a clean Rag (**Figure 47**).
2. Lubricate the Wheels at the grease fitting every 25 hours of operation.

Note: Pump the grease gun only until you feel slight resistance (2 - 3 pumps).

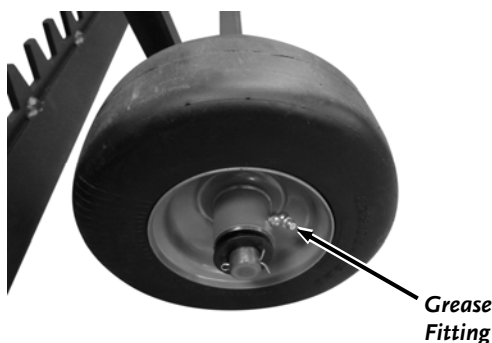

Figure 47

Chapter 5: Troubleshooting

Most problems are easy to fix. Consult the Troubleshooting Table below for common problems and their solutions. If you continue to experience problems, contact us at www.DRpower.com or call toll-free 1-800-DR-OWNER (376-9637) for support.

WARNING

Before performing any maintenance, you must first shut off the tow vehicle, remove the key and set the parking brake.

Troubleshooting Table

SYMPTOM	POSSIBLE CAUSE
<i>The wheels on the tow vehicle spin during the grading operation.</i>	<ul style="list-style-type: none">⇒ The Scarifying Teeth are set too low, causing too large a section of surface to be removed. Raise the height of the Scarifying Tooth Bar to improve traction.⇒ There is too much weight on the Crossmembers. Remove some of the weight.⇒ The Tow Vehicle is not adequate for your application.
<i>The Scarifying Teeth are not digging properly</i>	<ul style="list-style-type: none">⇒ The angle of the Tow Bar is not set correctly. Adjust the Tow Bar up for better grading or adjust the Tow Bar down for better scarifying.⇒ There is not enough weight for the hardness of the surface material. Add weight (no more than 80 pounds) to the Power Grader to improve performance⇒ The Wheels are adjusted not lifted all the way up. Raise the Wheels as needed.
<i>The Mold Board cannot be rotated to alternate angle settings</i>	<ul style="list-style-type: none">⇒ The lower hardware is too tight. Loosen the lower Bolt and Locknut to allow the Mold Board to rotate during adjustment. Tighten all hardware when angle adjustment is done.

Chapter 6: Parts Lists, Schematic Diagrams and Warranty

Parts List – CONTROL BOX ASSEMBLY

NOTE: Part numbers listed are available through DR Power Equipment.

<u>Ref#</u>	<u>Part#</u>	<u>Description</u>	<u>Ref#</u>	<u>Part#</u>	<u>Description</u>
1	38478	Actuator, Electric	24	35481	Wheel, 11 X 4-5, Flat Free, Smooth Tread
2	37973	Guide, Actuator	25	11073	Nut, Nylon Lock, 1/4-20, ZP
3	38472	Pin, Actuator Guide	26	37190	Pin, Cotter, 3/32" X 1", ZP
4	37961	Spacer, Actuator, Short	27	36736	Hand Control, Front
5	13447	Battery, 12v, 9ah	28	36303	Hand Control, Back
6	28697	Pad, Battery, 2.5" X 6.125"	29	36657	Switch, Rocker
7	38466	Grommet, Push In, 3/4" ID	30	37748	Harness, Actuator
8	37959	Spacer, Actuator, Long	31	37183	Wire Harness, Tether, Extension
9	37972	Spacer, Actuator, Middle	32	37182	Wire Harness, Control Box
10	38716	Rod, Battery	33	37112	Screw, Plastic Thread Forming, Pan Head, # 2 Philips, #8-18 X 3/4", STL, ZP
11	38715	Strap, Battery	34	38721	Nut, Wing, 3/8-16
12	38933	Cover, Actuator, w/Labels	35	11238	Washer, Flat, 1/4"
13	12683	Nut, 3/8-16, GR5, ZP	36	37977	Knob, Five Arm, 3/8-16
14	16413	Nut, Nylon Lock, 3/8-16, Low Profile	37	36737	Bolt, Shoulder, 1/2" X 3/8"L, 3/8-16
15	12170	Washer, Flat, 3/8", ZP, Ansi Narrow	38	37239	Bolt, HHCS, 3/8-16 X .75", GR5, ZP
16	22253	Washer, Lock, 3/8"	39	16484	Bolt, HCS, 3/8-16 X 2.5", GR5, ZP
17	18064	Washer, .8" ID, 1.5" OD X .11"	40	38720	Bolt, Shoulder, 10mm
18	36734	Cable, Adjust, Height, Electric	41	38723	Nut, Nylon Lock, M8
19	37965	Bracket, Axle, Mounting			
20	37963	Axle, (48" Model)	<u>Not Shown</u>		
	37964	Axle, (60" Model)	38912		Label, Branding
21	17351	Bolt, HHCS, 3/8-16 X 5", GR5, ZP	38913		Label, Raise/Lower, Control Box
22	15730	Bolt, HCS, 1/4-20 X 3/4, GR5 ZP	37854		Charger, Battery
23	36702	Spacer, Rail			

Schematic – CONTROL BOX ASSEMBLY

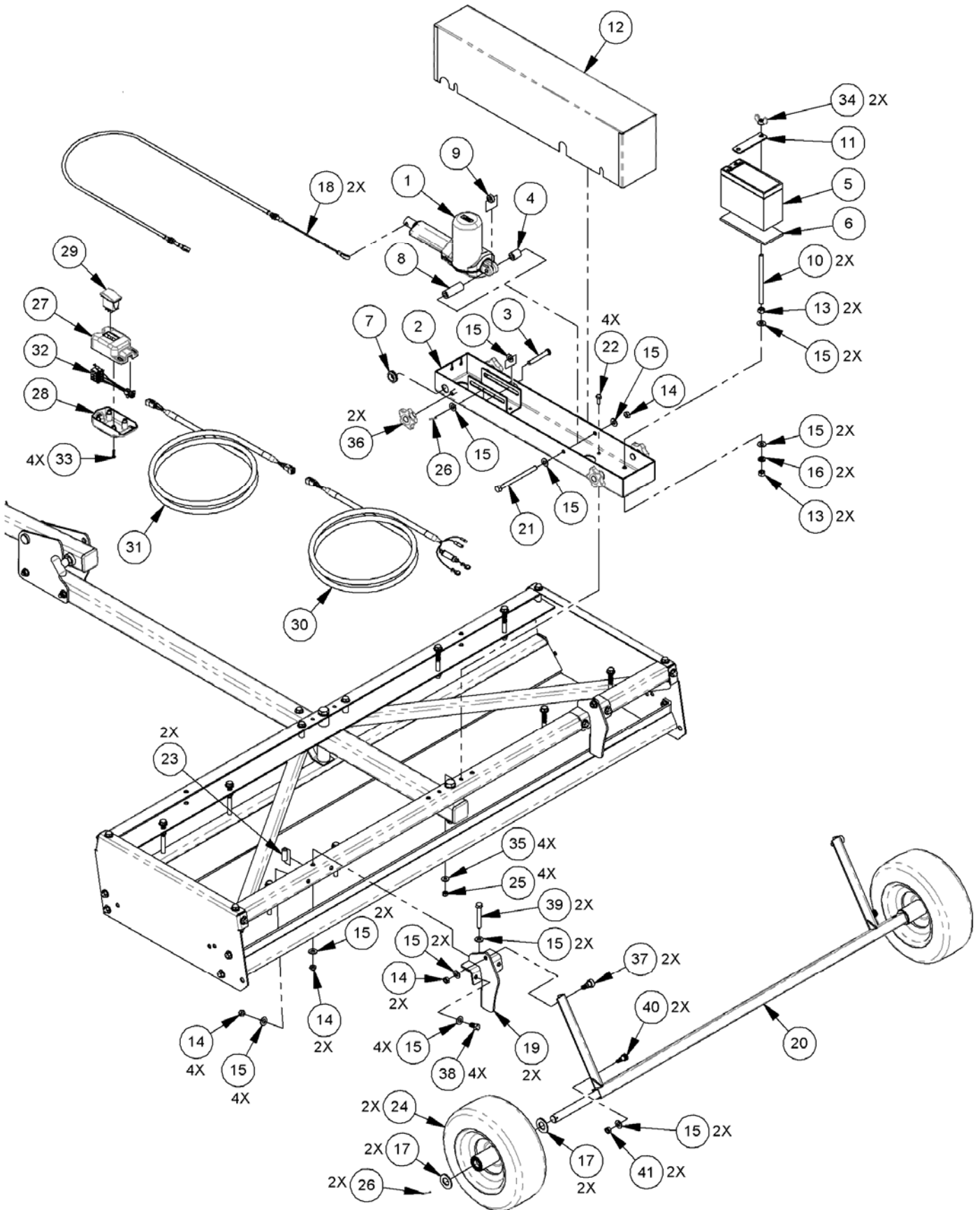

Schematic – FRAME ASSEMBLY

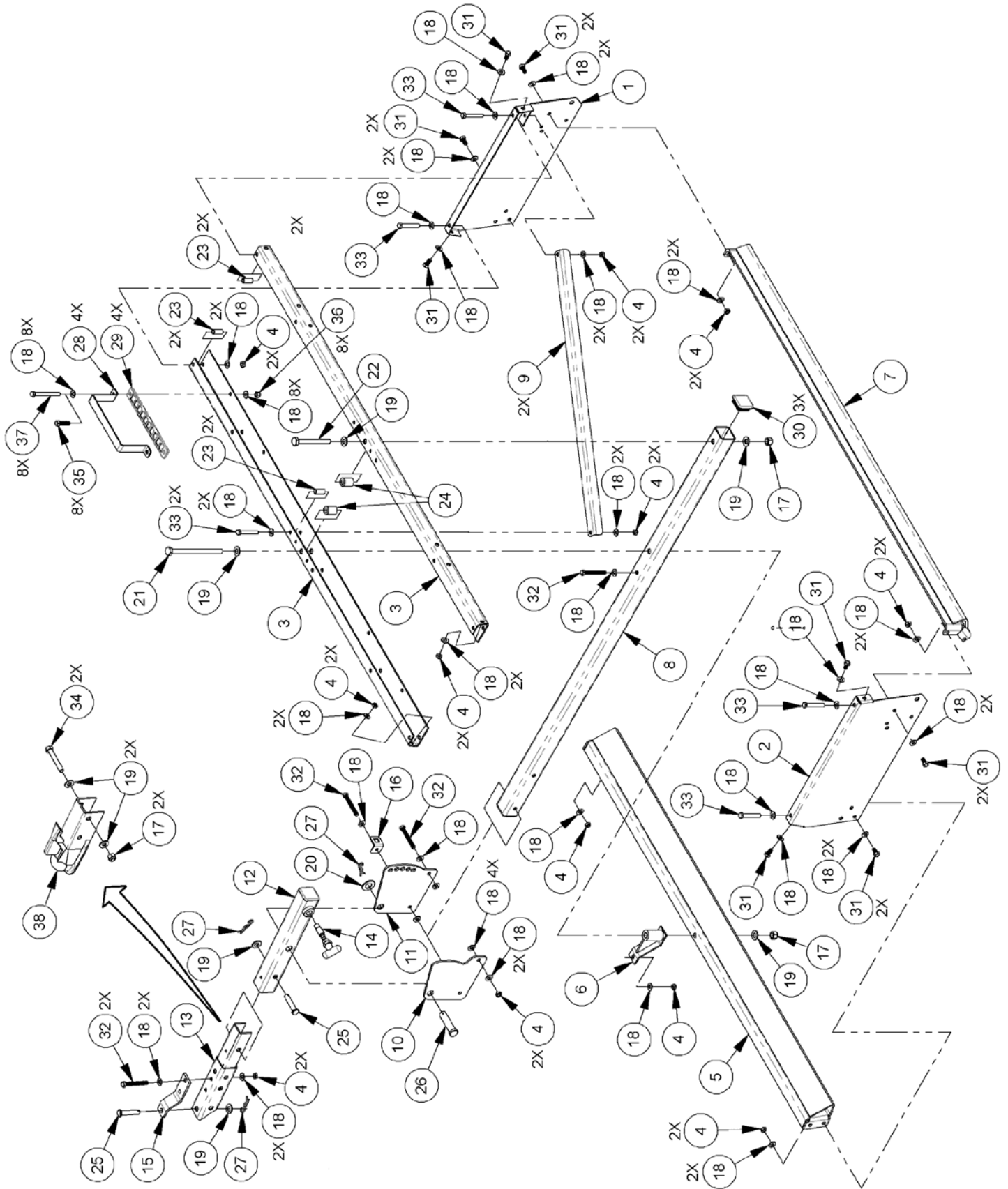

Parts List and Schematic – DR POWER GRADER Optional Drag Screen - Kit No. 21086 (48" Model) and 22686 (60" Model)

Note: Part numbers listed are available through DR Power Equipment.

Ref#	Part#	Description
01	21086	Drag Screen, 48", w/Chain and Links
	22686	Drag Screen, 60", w/Chain and Links
02	23099	Snap, Spring, 5/16"
03	21175	Connector, Threaded
04	21177	Chain, Tangle Resistant

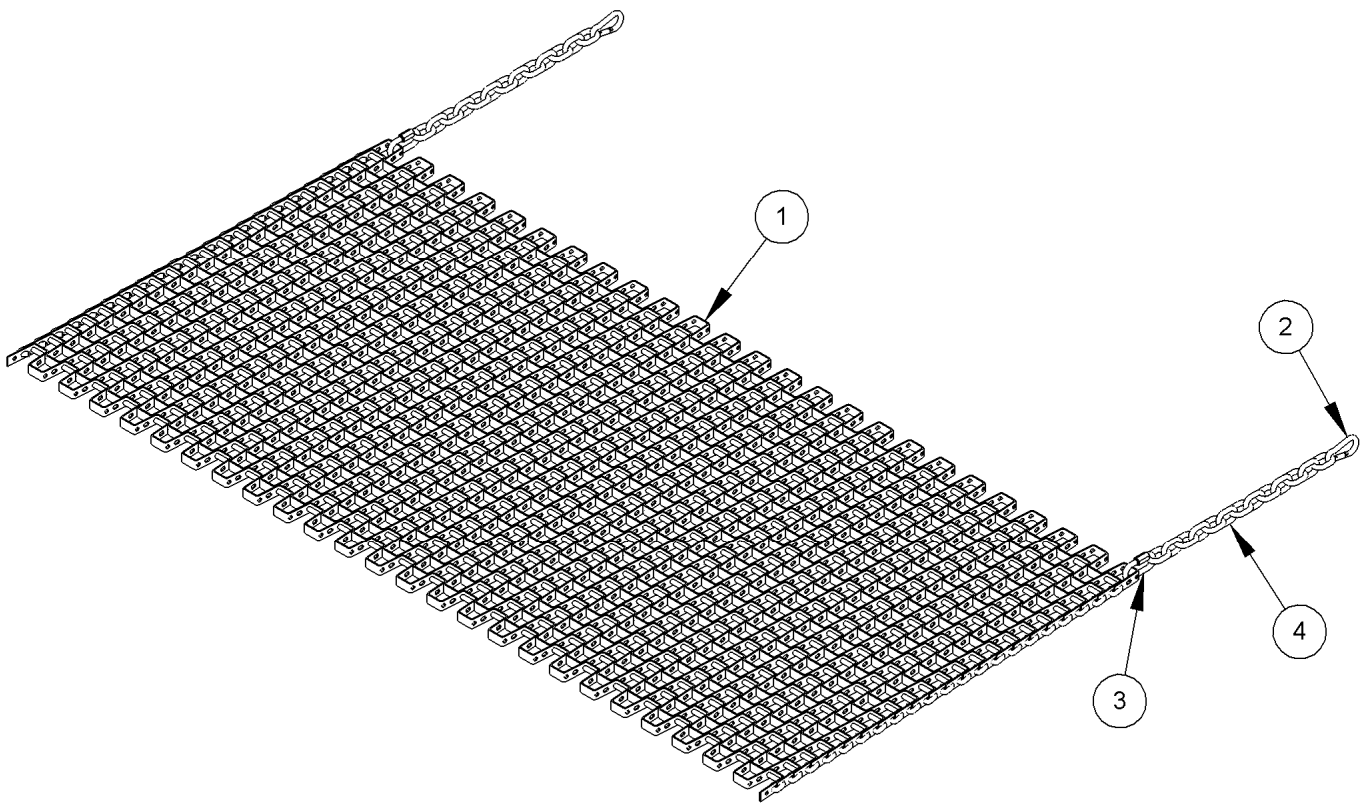

Notes:

Notes:

DR[®] POWER GRADER



2-Year Limited Warranty

Terms and Conditions

The DR[®] POWER GRADER is warranted for two (2) years against defects in materials or workmanship when put to ordinary and normal consumer use; ninety (90) days for any other use.

For the purposes of all the above warranties, "ordinary and normal consumer use" refers to non-commercial residential use and does not include misuse, accidents or damage due to inadequate maintenance.

DR Power Equipment certifies that the DR[®] POWER GRADER is fit for ordinary purposes for which a product of this type is used. DR Power Equipment however, limits the implied warranties of merchantability and fitness in duration to a period of two (2) years in consumer use, ninety (90) days for any other use.

The 2-Year Limited Warranty on the DR[®] POWER GRADER starts on the date the machine ships from our factory. The 2-Year Limited Warranty is applicable only to the original owner.

The warranty holder is responsible for the performance of the required maintenance as defined by the manufacturer's owner's manuals. The warranty holder is responsible for replacement of normally wearing parts such as the Battery, Scarifying Teeth and Mold Board. Accessories to the machine are not covered by this warranty.

During the warranty period, the warranty holder is responsible for the machine transportation charges, if required. During the warranty period, warranty parts will be shipped by standard method at no charge to the warranty holder. Expedited shipping of warranty parts is the responsibility of the warranty holder.

SOME STATES DO NOT ALLOW LIMITATIONS ON THE LENGTH OF IMPLIED WARRANTIES, SO THE ABOVE LIMITATIONS MAY NOT APPLY TO YOU.

DR Power Equipment shall not be liable under any circumstances for any **incidental or consequential damages or expenses** of any kind, including, but not limited to, cost of equipment rentals, loss of profit, or cost of hiring services to perform tasks normally performed by the DR[®] POWER GRADER.

SOME STATES DO NOT ALLOW THE EXCLUSION OR LIMITATION OF INCIDENTAL OR CONSEQUENTIAL DAMAGES, SO THE ABOVE LIMITATIONS MAY NOT APPLY TO YOU.

THIS WARRANTY GIVES YOU SPECIFIC LEGAL RIGHTS, AND YOU ALSO HAVE OTHER RIGHTS, WHICH VARY FROM STATE TO STATE.

Daily Checklist for the DR POWER GRADER

To help maintain your DR POWER GRADER for optimum performance, we recommend you follow this checklist each time you use your POWER GRADER.

WARNING

Before performing any maintenance, you must first shut off the tow vehicle, remove the key and set the parking brake.

- [] TOOTH BAR AND MOLD BOARD: The Tooth Bar and Mold Board endure most of the stress from the grading process. Check all nuts and bolts that secure the Tooth Bar and Mold Board to be sure that the components are secure.
- [] HARDWARE: Check all nuts and bolts and other fasteners to be sure that all components are secure.
- [] FRAME: Check all welds to be sure that the frame is intact and secure.
- [] CLEAN: Make sure the Tooth Bar and the Frame are clean and free of debris.

End of Season and Storage

WARNING

Before performing any maintenance, you must first shut off the tow vehicle, remove the key and set the parking brake.

- Hose down the DR POWER GRADER. Remove the Tooth Bar to clean it of debris and then replace it after cleaning the mounting surfaces.
- Lubricate the Rear Wheels.
- Wipe down the DR POWER GRADER to remove any moisture and dirt that may have accumulated.
- If possible, store the Power Grader in a dry, protected place. If it is necessary to store the Power Grader outside, cover it with a protective material.
- Store the Battery in a dry area that will not freeze. If you will not use the machine over a long period, charge the Battery every four to six weeks.



75 MEIGS ROAD, P.O. BOX 25, VERGENNES, VERMONT 05491